

Installation and User Manual

SL60-501

Revision A **!!!DRAFT!!!**



TABLE OF CONTENTS

1 Introduction	5	3.3 Link distance / Link availability	17
1.1 Intended users	5	3.4 Terminal mounting options	17
1.2 Revision	5	3.4.1 Wall mounting	17
1.3 Prior knowledge	5	3.4.2 Pole mounting	18
1.4 Used symbols	6	3.5 Cabling	18
1.5 Warranty	6	3.6 Grounding / Lightning protection	18
1.6 Copyright / Disclaimer	7	3.7 Co-located applications	19
2 System overview	8	4 Installation	20
2.1 General description	8	4.1 Mount installation	20
2.1.1 Benefits	8	4.1.1 Wall mount	20
2.1.2 Applications	9	4.1.2 Mast mount	21
2.2 Package contents	10	4.2 Terminal installation	22
2.3 System components	10	4.3 Cable installation	22
2.3.1 Terminals	11	4.4 Antenna alignment	23
2.3.2 Alignment bracket	11	4.4.1 Alignment Procedure	24
2.3.3 Alignment tool	12	4.4.1.1 Optical alignment	24
2.3.4 Ice bridge	12	4.4.1.2 Power level alignment	25
2.3.5 Sealed Ethernet connector	12	4.5 Grounding	25
2.3.6 Accessories	13	4.6 Lightning / Surge protector	26
2.3.6.1 PoE injector (accessory)	13	4.7 Power injector	26
2.3.6.2 Data line protector (accessory)	13	5 Terminal management and monitoring functions	27
2.3.6.3 Mast bracket (accessory)	14	5.1 Web browser interface	28
2.3.6.4 Ethernet cables (accessory)	14	5.1.1 System overview screen	28
3 Site planning	15	5.1.1.1 Traffic light colors	28
3.1 Terminal location	16	5.1.2 Password screen	28
3.2 Line of sight	16	5.1.3 Firmware update screen	29

5.1.4 Network configuration screen	29	A.4 Availability / Rain zone / Link distance	43
5.1.5 Radio alignment screen	30	A.4.1 Map of America	43
5.1.6 Network statistics screen	30	A.4.2 Map of Asia and Middle East	44
5.1.7 SNMP configuration screen	31	A.4.3 Map of Europe	45
5.1.8 VLAN configuration screen	31	B Regulatory information	47
5.2 Parameter reset	32	B.1.1 FCC statement	47
5.3 Firmware upload	32	B.1.2 Industry Canada statement	48
5.4 SNMP interface	33	B.1.3 CE – Declaration of conformity	49
A Technical information	35	B.1.4 Safety	50
A.1 Troubleshooting	35	B.1.4.1 English	50
A.1.1 Power and network connection	35	B.1.4.2 Deutsch	51
A.1.2 Network configuration	35	B.1.4.3 Français	51
A.1.3 Duplex mismatch	36	B.1.4.4 Italiano	52
A.1.4 Miss-alignment	37	C Contacts	53
A.2 Specifications	38	C.1.1 Technical assistance	53
A.2.1 Ethernet cable colour code	41	C.1.2 Service center / RMA	53
A.3 Receiver level / Rain / Link distance	42	D Glossary	54

1 INTRODUCTION

1.1 Intended users

This manual is intended for all installation and service personnel who are involved in the planning, installation, operation and maintenance of SL60-501 equipment.

Please read the complete SL60-501 (SENCITY@Link) manual prior to its unpacking, installation, setup and deployment.

Although the SENCITY@Link is designed for easy installation and setup, optimum performance can be achieved by following the procedures outlined in this manual.

1.2 Revision

HUBER+SUHNER reserves the right to revise this documentation periodically without any obligation to provide notification of such revision or changes. The latest revision can be downloaded on <http://www.hubersuhner.com/sl60>.

1.3 Prior knowledge

This manual assumes that the installer has at least a basic experience and understanding of networking equipment, as well as some familiarity with its configuration and operation. The information covered in this manual should be fully understood prior to installation.

1.4 Used symbols

Danger

Not used

Warning

Risk for human and equipment

Caution

Risk for equipment and functionality

Advice

1.5 Warranty

HUBER+SUHNER warrants to the original end user (purchaser) that this product is free from any defects in materials or workmanship for a period of up to one year from the date of shipment to the end user.

During the warranty period, and upon proof of purchase, should the product show indications of failure due to faulty workmanship and/or materials, HUBER+SUHNER will, at its discretion, repair or replace the defective products or components without charge for either parts or labor, and to whatever extent it shall deem necessary to restore the product or components to full operating condition. Any replacement will consist of a new or remanufactured,

functionally equivalent product of equal value, and will be offered solely at the discretion of HUBER+SUHNER. This warranty shall not apply if the product is modified (e.g. warranty seal is broken), misused, tampered with, damaged by an act of God, or subjected to abnormal working conditions.

To obtain services under this warranty, contact HUBER+SUHNER's Service Center, referring to your Return Material Authorization number (see C.1.2). Products must be returned Postage Prepaid. It is recommended that the terminal be insured when shipped. Any products returned without either proof of purchase or with an outdated warranty will be repaired or replaced and the customer will be billed for parts and labor. All repaired or replaced products will be shipped by HUBER+SUHNER to the corresponding return address 'Postage Paid' (USA only). If the customer specifies some other return destination beyond US borders, the customer shall bear the cost of the return shipment. This warranty gives you specific legal rights, and you may also have other rights that vary from state to state.

1.6 Copyright / Disclaimer

Copyright © 2009 by HUBER+SUHNER

The contents of this publication may not be reproduced in any part or as a whole, transcribed, stored in a retrieval system, translated into any language, or transmitted in any form or by any means, electronic, mechanical, magnetic, optical, chemical, photocopying, manual, or otherwise, without the prior written permission of HUBER+SUHNER.

2 SYSTEM OVERVIEW

2.1 General description

The SL60-501 system operates as a data link in the unlicensed 60 GHz band between 57 GHz and 64 GHz and delivers a full duplex data rate of up to 160 Mbps over a distance of up to 1000 m (3280 ft).

Measuring only 16 cm × 16 cm (6.3" × 6.3"), the terminal's compact size is attained by extensively integrating the active and passive components.

For more detailed technical data see appendix A.2.



2.1.1 Benefits

- Easy installation – The concept of the SENCITY@Link allows to the end user to install it as easy as any other network component.
The single cable solution reduces the complexity of the installation. The terminal is connected to the network, monitored and supplied with power through a single outdoor rated CAT 6 Ethernet cable.
The visual alignment tool and an alignment bracket allows the user to easily install the link.
Immediate operation without the need of additional configuration is granted.
- Network performance – Guaranteed full duplex 100 Mbps along the complete range. Unlike typical WLAN equipment the user can transmit a full 100 Mbps over the link.
- License free operation – The system has been approved and can be operated in many countries.
- System administration – To monitor the status and the traffic the user can access the link statistics either via the HTML user interface or by integrating it into a network management tool via SNMP.
- Security – The proprietary radio interface does not allow any other system to access the 60 GHz transmitted data.

A high level of data security is inherent in the product via signal absorption by atmospheric oxygen and the use of high gain/narrow beam width antennas.

2.1.2 Applications

- LAN extension
- Redundant access
- Campus connectivity
- Disaster recovery
- Wireless backhaul
- Centralization of IT infrastructure
- Temporary connections during events
- Mesh and hub and spoke configuration

Nevertheless, when working on a roof, ladder, mast or staging, please take extreme care, observing all facility and OSHA (or other applicable regulatory agency) required safety precautions.

2.2 Package contents

All equipment and installation material is packed into one box. This is divided into three cartons containing the following items:

- Carton A:
 - Terminal A
 - Bracket
 - Mounting set
- Carton B:
 - Terminal B
 - Bracket
 - Mounting set
- Carton C:
 - Manual
 - Reset-CD
 - Ice bridges
 - Accessories
- Required tools:
 - Adjustable-end wrench

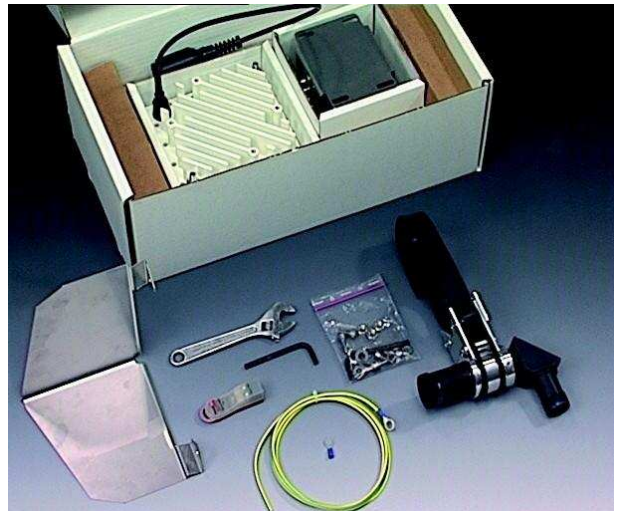

2.3 System components

The SL60-501 system is composed of the following components:

- Terminal A and Terminal B
- Alignment bracket
- Alignment tool
- Ice bridge
- Sealed Ethernet connection

- Main accessories:
 - PoE injector
 - Lightning protector
 - Mast bracket
 - Ethernet cables

2.3.1 Terminals

The terminals are the main system components. They combine the antenna, transmitter and receiver and are connected to the network via a standard Ethernet cable with RJ-45 connector.

Power is supplied through the Ethernet cable to the terminal. This will require either a PoE (802.3af) compatible network equipment or an additional PoE injector.



2.3.2 Alignment bracket

The alignment bracket facilitates installation and positioning owing to its independent axis with coarse and fine alignment capabilities.

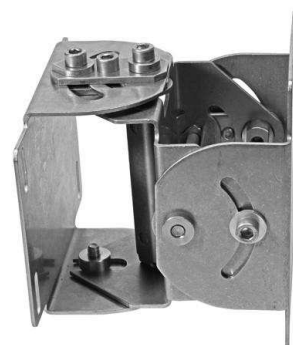

2.3.3 Alignment tool

The optical alignment tool provided is easily mounted on the terminal using an elastic band. It enables both ends of the link to be aligned quickly, simply and independently.



2.3.4 Ice bridge

The ice bridge offers an additional protection for the terminal against rain, snow and ice-formation.



2.3.5 Sealed Ethernet connector

The seal kit is used to make a watertight connection of the Ethernet coupling. Please use the separate instructions for a proper installation of the seal kit.



2.3.6 Accessories

2.3.6.1 PoE injector (accessory)

The terminal is powered via Ethernet cable according to the IEEE 802.3af PoE standard. Should the network equipment connected to the SENCITY®Link does not offer PoE, a power injector can be inserted in line to the Ethernet cable.

Order information:

Item number	Description
84021333	PoE 802.3af Power Injector



2.3.6.2 Data line protector (accessory)

HUBER+SUHNER strongly recommends the installation of an outdoor data line protector to provide lightning and surge protection for the building, personnel and equipment. Please refer to the local and/or national electrical and building codes.

Order information:

Item number	Description
23033695	Data Line Protector (indoor) To use only in combination with an outdoor protector.
84014284	Data Line Protector (outdoor)



Outdoor



Indoor

2.3.6.3 Mast bracket (accessory)

The mast bracket is used to mount the bracket onto a mast. The bracket is suitable for any pole diameter from 50 mm to 115 mm (2" to 4,5").

Order information:

Item number	Description
84015652	Mast Bracket

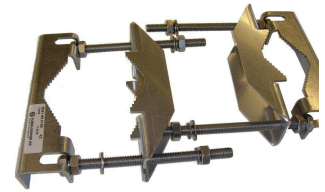

2.3.6.4 Ethernet cables (accessory)

The length of the cable linking the SENCITY®Link to the next network node may be up to 100 m (328 ft) in length. It should, however, be kept as short as practical in order to minimize signal losses. All Ethernet cables must be CAT 5e compliant and suitable for outdoor use. The cable must be UV stable, UL approved and comply with local and/or national building codes.

Order information:

Item number	Description
84031068	Outdoor Ethernet Cable 2 m
84028025	Outdoor Ethernet Cable 10 m
84028026	Outdoor Ethernet Cable 30 m
84028029	Outdoor Ethernet Cable 90 m



3 SITE PLANNING

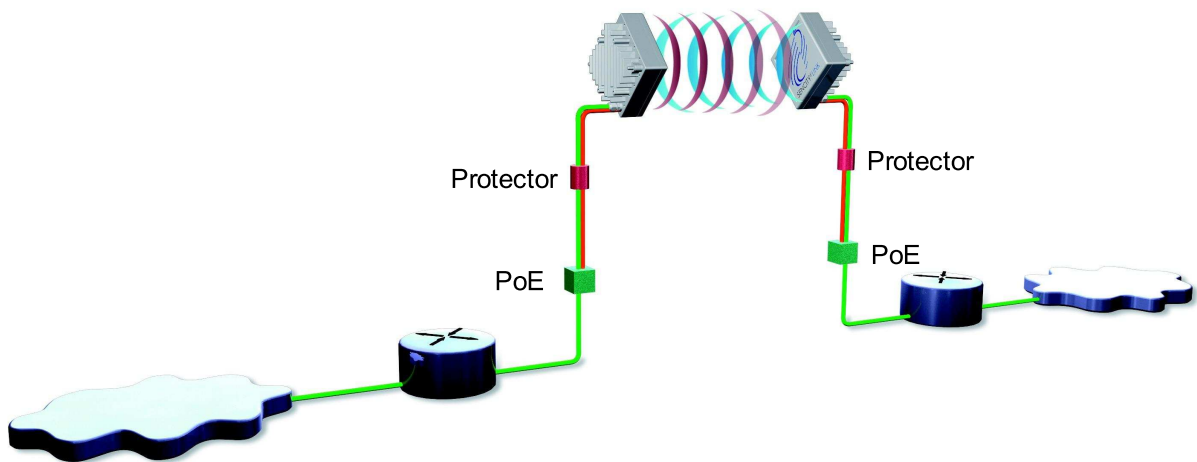

All installers must perform a full site inspection and plan carefully prior to the physical installation of an SL60-501 system.

This preparation must include:

- Evaluating the most appropriate location for the installation of the terminal.
- Identifying an appropriate mounting structure (wall or mast) for each terminal.
- Planning the cable routing from the network component to the terminal.

3.1 Terminal location

When selecting the best terminal location the following factors should be considered:

- Accessibility (e.g. roof)
- Type of mounting (e.g. wall or pole)
- Grounding connection point
- Cable runs (max. 100 m / 328 ft)
- Line of sight

Use of given protection against sun, rain, etc. will increase the equipment performance.

3.2 Line of sight

To ensure a clear line of sight, there must be no obstructions between the two terminal locations. The required clearance can be established visually using the following table¹:

Link distance	Boundary diameter
100 m (328 ft)	0.7 m (2.3 ft)
200 m (656 ft)	1.0 m (3.3 ft)
400 m (1312 ft)	1.4 m (4.6 ft)
600 m (1968 ft)	1.7 m (5.6 ft)
800 m (2625 ft)	2.0 m (6.6 ft)

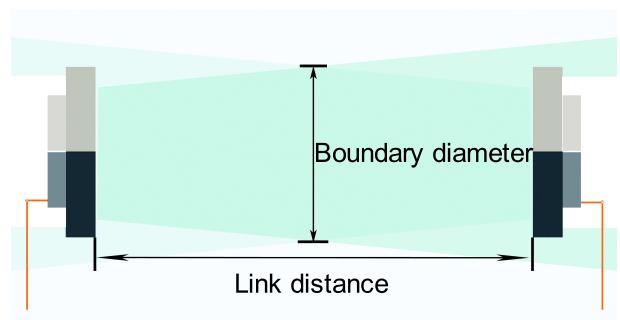

¹ Fresnel zone calculation

3.3 Link distance / Link availability

The link distance is directly related to the weather conditions.

The affordable link availability is influenced by the following environmental conditions:

- Rain: the less, the better
- Temperature: the higher, the better
- Air pressure: the lower, the better

Knowledge of the link distance (line of sight) is important in estimating link quality.

For different maps of the world including the rain regions see appendix A.4.

3.4 Terminal mounting options

3.4.1 Wall mounting

The wall mounting location should be strong enough to secure the terminal to the wall, taking into account all foreseeable environmental conditions (e.g. wind, rain, ice).

Depending on the material to which the bracket is mounted, differently sized mounting hardware may be necessary.

To mount the terminal onto the bracket use the enclosed M6 bolts. The bracket allows a tilt angle of +/- 50° in both axis.

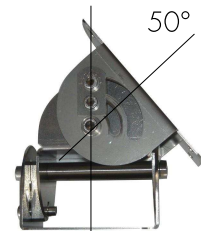

3.4.2 Pole mounting

The pole mounting kit will be needed to mount the terminal onto poles with diameters from 50 mm to 115 mm (2" to 4,5").

3.5 Cabling

The terminal is delivered with an Ethernet cable terminated with a RJ-45 plug connector. To connect the SENCITY@Link to your network, use a CAT 5e Ethernet cable with a maximum length of 100 m to the next network node. Please verify too that the cable used is designed for outdoor environments (e.g. water, solar UV). Since the power is supplied by the Ethernet cable, please make sure that network equipment used supports Power over Ethernet (PoE). If not, use a PoE injector according to IEEE 802.3af. SENCITY@Link can handle crossover and straight cables.

3.6 Grounding / Lightning protection

The terminal must be properly grounded to provide protection against voltage surges.

In the event of a short circuit or lightning strike, effective grounding can prevent damage to building, equipment, infrastructure and personnel. For installations in the USA, refer to Article 830 of the National Electrical Code (Network-powered broadband communications systems), for all other countries, implement protection in accordance

with the safety standards and regulatory requirements of the country in which the equipment is installed.

HUBER+SUHNER strongly recommends the use of outdoor lightning protectors.

3.7 Co-located applications

Owing to the compact size of the SL60-501 integrated terminal, it is particularly suitable for co-sited applications.

Possible configurations include:

- Back-to-back - e.g. doubles the link distance
- Parallel link - doubles data capacity or redundancy
- Star - hub and spoke

To deploy a co-sited application, please contact HUBER+SUHNER to assist with devising an appropriate site design.

4 INSTALLATION

Owing to the small size and integrated design of the SENCITY@Link, its correct installation and setup is relatively simple.

Nevertheless, when working on a roof, ladder, mast or staging, please take extreme care, observing all facility and OSHA (or other applicable regulatory agency) required safety precautions.

4.1 Mount installation

4.1.1 Wall mount

The wall and mounting screws must be able to support a weight of 11 pounds (5 kg), taking into account associated wind and potential ice loading factors.

To ensure the use of the correct screws for the installation, HUBER+SUHNER recommends consulting HILTI's online Anchor System Advisor at http://www.us.hilti.com/holus/modules/adansel/adas_oview.jsp



Right

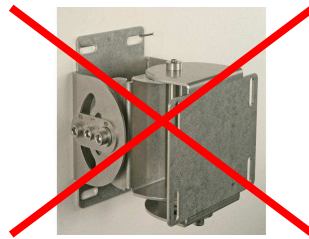

Wrong

4.1.2 Mast mount

- Ensure that the mast used has a diameter of between 50 mm to 115 mm (2" to 4.5").
- Use a 13 mm flat wrench (~½") to fasten the M8 screw nut.
- Fasten the alignment bracket onto front part of mast bracket using the enclosed stainless steel screws, nuts and washer (M6).
- Fix the front part of the mast bracket and the attached alignment bracket on the mast.

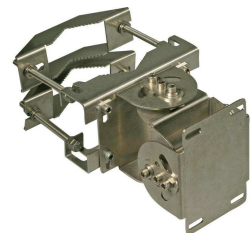

Do not use zinc plated screws as these will corrode and endanger link performance and environment.

4.2 Terminal installation

It is important to install the terminal on the bracket with the same orientation (antenna polarization) at both ends of the link. The terminal must be mounted on the bracket in such a way that the polarization arrow points to the same direction at both ends of the link. The terminal must be mounted on the bracket by using the allen key with the enclosed stainless steel screws (M6 x 12).

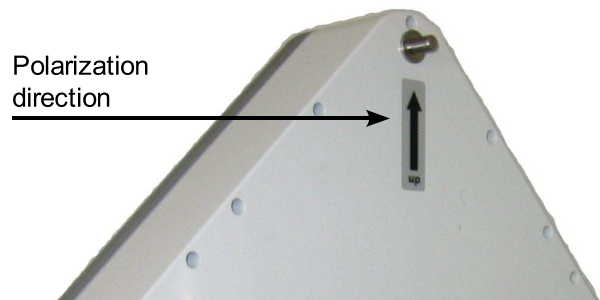

Do not use zinc plated screws as these will corrode and endanger link performance and environment.

4.3 Cable installation

The length of the cable from the terminal to the next network component may be up to 100 m (328 ft) in length, but should be kept as short as practical in order to reduce signal loss. All Ethernet cables must be CAT 5e compliant and suitable for outdoor use. The cable must be UV stable, UL approved and must comply with local and/or national building codes.



To enter the building, HUBER+SUHNER recommends using cable seals from Roxtec (<http://www.roxtec.com>).

4.4 Antenna alignment

One of SENCITY@Link's biggest advantage is its fast, easy alignment procedure.

The terminals can be aligned optically by using the alignment tool. No electrical alignment is required, although possible.

The table below shows the alignment tolerance:

Link distance		Alignment accuracy	
100 m	328 ft	0.9 m	2.9 ft
400 m	1312 ft	3.5 m	11.5 ft
600 m	1968 ft	5.2 m	17.2 ft
800 m	2625 ft	7.0 m	22.9 ft

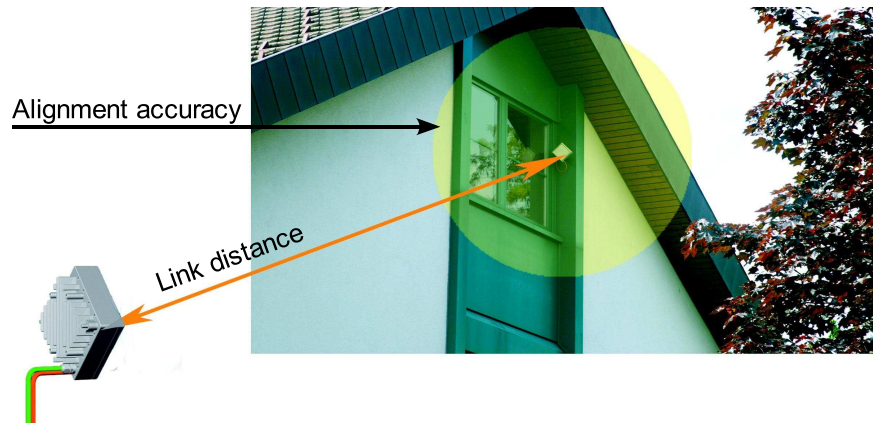

4.4.1 Alignment Procedure

The following procedure achieves fast, accurate alignment (for all operations, the enclosed 5 mm allen key can be used):

4.4.1.1 Optical alignment

- a) Place the alignment tool to the most accessible corner and ensure good visibility to the opposite terminal by rotating the telescope.
- b) Loosen the horizontal lock screws (labeled "3")
- c) Place the horizontal axis course screw in its middle position (needle).
- d) Carry out a rough alignment on the horizontal axis and fasten the screw (labeled "1").



- e) Repeat steps b), c) and d) for the vertical axis.

Horizontal alignment

- f) Turn the horizontal course screw (labeled "2") by viewing through the telescope and carrying out the fine alignment.

Wall

- g) Repeat e) for the vertical axis.

Vertical alignment

- h) If necessary, repeat the fine alignment procedure e) for both axes until the opposite link is correctly aligned.

- i) Fasten the lock screw (labeled "3") on both horizontal and vertical axes.

2 Fine alignment

1 Coarse alignment

3 Lock

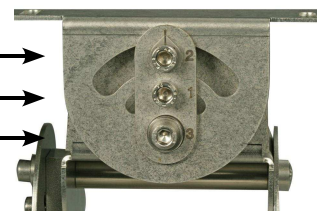

4.4.1.2 Power level alignment

Optionally (but recommended), an alignment based on the receiver power level of each terminal can be done. The power level can be accessed via the web interface (see section 5.1.5).

As described in section 4.4.1.1, it is recommended to proceed first with a rough horizontal (respectively vertical) alignment and then to do a fine alignment on each axis. Do not forget to loosen (respectively tighten) the two lock screws before (respectively afterwards). See chapter A.3 for an estimation of the power levels at different rain rates and link distances.

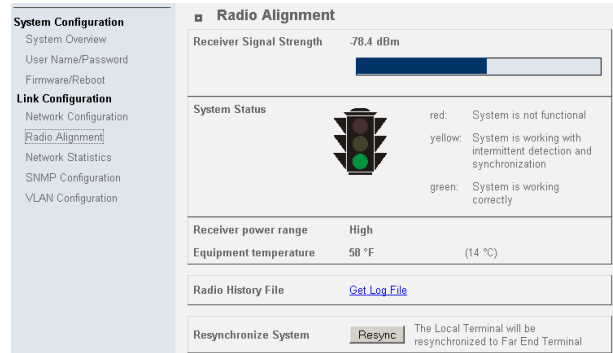

A power level of -60dBm is better than a power level of -70dBm

4.5 Grounding

The terminal must be properly grounded.

Two screws are provided on the reverse housing of the terminal to facilitate the correct grounding. To fasten the grounding cable onto the terminal, use a lug and serrated washer combined with an M8 nut. Connect the terminal to the connection points nearest

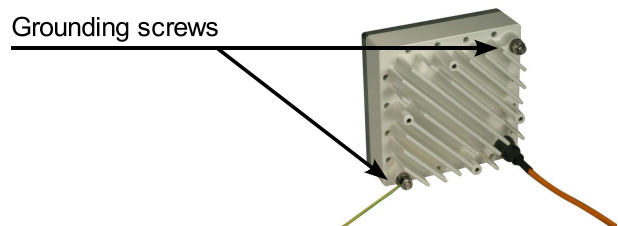

to the building-to-earth ground point. The grounding conductor must be as short as is practical and should not exceed 6 m (20 ft). For installations in the USA, refer to Articles 830 of the National Electrical Code (Network-powered broadband communications systems). For installations in all other countries, refer to the safety standards and regulatory requirements.

4.6 Lightning / Surge protector

HUBER+SUHNER strongly recommends the use of outdoor data line protectors.

To protect humans and the building a protector must be installed before the cable enters the building. For detailed installation instructions, please refer to the dedicated documents enclosed to the protectors:

Outdoor protector 3414.99.0008 84016716

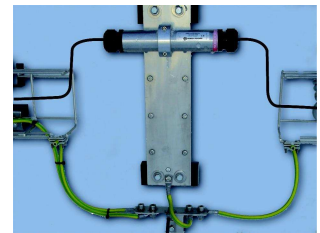

4.7 Power injector

The power injector is connected inline into the data line. The maximum distance between the PoE and the SENCITY®Link is 100 m (328 ft). The PoE must be IEEE 802.3af compliant. To check that the injector is functioning correctly, use the PoE Tester (see accessories order information in section Error: Reference source not found).



5 TERMINAL MANAGEMENT AND MONITORING FUNCTIONS

For an initial configuration, use a PC or laptop. Address the terminal with the appropriate IP address.

Every terminal is labeled with its terminal type (A or B).

The factory default values are:

Terminal	IP address	Subnet mask	User name	Password
A	192.168.0.11	255.255.255.0	admin	sl60
B	192.168.0.12	255.255.255.0	admin	sl60

To communicate with the terminal, ensure that the IP address of the computer used is not allocated automatically by the DHCP server. Configure the IP address manually - e.g. 192.168.0.1 with subnet mask 255.255.255.0. Remember to ensure that your web browser is not using any proxy server settings.

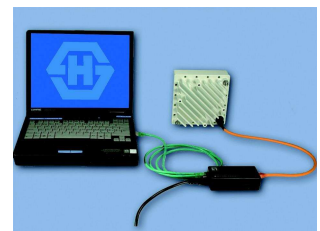
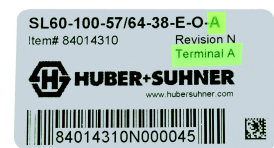

Note:

The IP address settings have no influence on data connectivity. This settings are only needed to access the terminal monitoring functions of the terminal.

5.1 Web browser interface

5.1.1 System overview screen

This screen shows an overview of key link information including its current status.

5.1.1.1 Traffic light colors

Green:	System is working correctly
Yellow:	System is working with intermittent detection and synchronization
Red:	System is not functional

The screenshot shows the 'System Overview' configuration page. On the left is a navigation menu with categories: System Configuration (containing System Overview, User Name/Password, and Firmware/Reboot) and Link Configuration (containing Network Configuration, Radio Alignment, Network Statistics, SNMP Configuration, and VLAN Configuration). The main content area is titled 'System Overview' and contains the following fields and information:

- System name:** SENCITYlink A (max: 16 characters)
- Location:** Building A (max: 32 characters)
- System Status:** Indicated by a traffic light icon with the green light lit. A legend explains the colors: red for 'System is not functional', yellow for 'System is working with intermittent detection and synchronization', and green for 'System is working correctly'.
- Serial number:** 84014310N000024
- Terminal Type:** A
- Firmware version:** 1.40
- Physical address (MAC):** 00:8D:86:00:04:84
- Hour meter:** 18278 h
- Time since last system reboot:** 000:00:13:11

At the bottom of the main content area are 'Apply' and 'Cancel' buttons.

5.1.2 Password screen

Default user name: admin
Default password: sl60

The screenshot shows the 'User Name/Password' configuration page. It features the same navigation menu as the previous screen. The main content area is titled 'User Name/Password' and contains the following fields:

- User name:** admin (max: 16 characters)
- Current password:** masked with dots (max: 16 characters)
- New password:** masked with dots (max: 16 characters)
- Retype Password:** masked with dots (max: 16 characters)

'Apply' and 'Cancel' buttons are located at the bottom of the form.

5.1.3 Firmware update screen

Current firmware can be downloaded from <http://www.hubersuhner.com/sl60> or requested via technical support. The downloaded file should be saved on the local computer and then uploaded to each terminal through the firmware update form on the web interface.

The screenshot shows the 'Firmware Update' section of the web interface. On the left is a navigation menu with 'System Configuration' expanded to show 'Firmware/Reboot'. The main content area has two sections: 'Firmware Update' and 'Sysconfig Update'. The 'Firmware Update' section shows 'Firmware Version 1.40', an 'Upload firmware file' input field with a 'Browse...' button, and a 'Start Upload' button. The 'Sysconfig Update' section shows an 'Upload sysconfig file' input field with a 'Browse...' button and a 'Start Upload' button. Below these are three buttons: 'Get sysconfig of this device', 'Reset System to factory settings' with a 'Reset' button, and 'Reboot System' with a 'Reboot' button.

5.1.4 Network configuration screen

The network configuration screen offers the option to change network settings if required. The IP address settings have no influence on data connectivity.

The screenshot shows the 'Network Configuration' section of the web interface. On the left is a navigation menu with 'System Configuration' expanded to show 'Network Configuration'. The main content area has two sections: 'TCP/IP Configuration' and 'Configuration of Ethernet Interface'. The 'TCP/IP Configuration' section has radio buttons for 'Get automatically (DHCP)' and 'Manual configuration'. Under 'Manual configuration', there are input fields for 'IP address' (172, 21, 2, 25), 'Network mask' (255, 255, 255, 0), 'Default gateway' (172, 21, 2, 1), and two 'Domain name server' fields. The 'Configuration of Ethernet Interface' section has radio buttons for 'AutoNegotiate' and 'Manual configuration'. Under 'Manual configuration', there are radio buttons for 'Duplex' (Half-duplex, Full-duplex) and 'Speed' (10 mps, 100 mps). There are also radio buttons for 'Auto MDI/MDIX' and 'Manual configuration'. Under 'Manual configuration', there are radio buttons for 'MDIX' (Force MDIX Mode, No MDIX Mode) and a 'Physical address (MAC)' field with the value 00:0D:86:00:04:84. At the bottom are 'Apply' and 'Cancel' buttons.

5.1.5 Radio alignment screen

The radio alignment screen shows specific details relating to the alignment of the two terminals.

The radio history file does log (once a minute) the following parameter values for the last 48 hours:

- Time since last reboot
Time format: <days>.<hours>:<minutes>
- Receive power at time XY ("minus" sign omitted)
- Device temperature in °C
- Lock detector: if unequal to 1, then the receivers are not locked

System Configuration
System Overview
User Name/Password
Firmware/Reboot

Link Configuration
Network Configuration
Radio Alignment
Network Statistics
SNMP Configuration
VLAN Configuration

Radio Alignment

Receiver Signal Strength -78.4 dBm

System Status

Receiver power range High
Equipment temperature 58 °F (14 °C)

Radio History File [Get Log File](#)

Resynchronize System The Local Terminal will be resynchronized to Far End Terminal

The resynchronization button can be used to restart the synchronization process with the far end terminal.

5.1.6 Network statistics screen

The network statistics screen shows standardized information relating to network traffic and errors. Traffic status information is continuously updated and specific network errors are listed.

System Configuration
System Overview
User Name/Password
Firmware/Reboot

Link Configuration
Network Configuration
Radio Alignment
Network Statistics
SNMP Configuration
VLAN Configuration

Network Statistics

The table displays the gathered packages over a period of 10 sec.

	Ethernet	Air
Pkts In (Rx)	135	125
Pkts Out (Tx)	126	134
Pkts Errors/Dropped (Rx)	0	0

5.1.7 SNMP configuration screen

The SL60-501 terminal can be integrated into a network management system by using the implemented SNMP agent. This agent supports GET and TRAP functionality. No setting can be performed via SNMP.

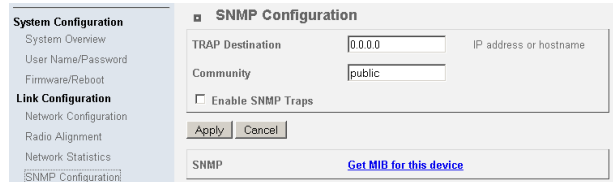

The screenshot shows a web interface for configuring SNMP. On the left is a navigation menu with sections: System Configuration (System Overview, User Name/Password, Firmware/Reboot) and Link Configuration (Network Configuration, Radio Alignment, Network Statistics, SNMP Configuration). The main area is titled 'SNMP Configuration' and contains: TRAP Destination (input field with '0.0.0.0', label 'IP address or hostname'), Community (input field with 'public'), and an unchecked checkbox for 'Enable SNMP Traps'. There are 'Apply' and 'Cancel' buttons. At the bottom, there is a link labeled 'SNMP' with a sub-link 'Get MIB for this device'.

Note:

To use this feature you need an SNMP manager program such as HP OpenView or Castlerock's SNMPc.

The MIB file can be downloaded directly from the terminal.

5.1.8 VLAN configuration screen

The SL60-501 terminal can be integrated into a VLAN. Configure the VLAN ID, IP address and subnet mask accordingly.

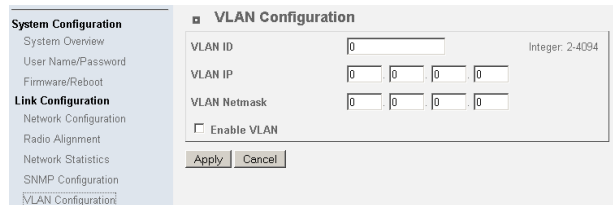

The screenshot shows a web interface for configuring a VLAN. On the left is a navigation menu with sections: System Configuration (System Overview, User Name/Password, Firmware/Reboot) and Link Configuration (Network Configuration, Radio Alignment, Network Statistics, SNMP Configuration, VLAN Configuration). The main area is titled 'VLAN Configuration' and contains: VLAN ID (input field with '0', label 'Integer: 2-4094'), VLAN IP (input field with '0', label 'Integer: 0-255'), and VLAN Netmask (input field with '0', label 'Integer: 0-255'). There is an unchecked checkbox for 'Enable VLAN'. There are 'Apply' and 'Cancel' buttons.

5.2 Parameter reset

The parameter reset function will reset all terminal parameters (e.g. IP address, username, password) to the factory defaults.

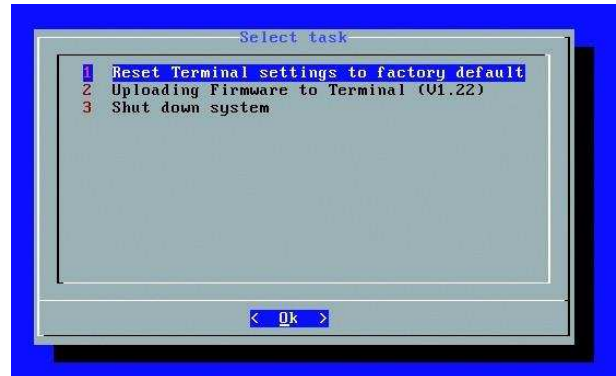

5.3 Firmware upload

With the firmware upload functionality a firmware can be uploaded to the terminal even the previous installed firmware is lost by power breakdown or Ethernet connectivity break during firmware upload process.

The CD contains useful documents (manual, installation video, etc.)

5.4 SNMP interface

Object	OID	OID type	Description
MIB-2			
(iso.org.dod.internet.mgmt.mib-2.system.x / .1.3.6.1.2.1.1.x)			
sysDescr	.1.	DisplayString	Includes serial no.
sysUpTime	.3.	TimeTicks	Uptime of the network management
sysName	.5.	DisplayString	set in the web GUI
sysLocation	.6.	DisplayString	set in the web GUI
HUBERSUHNER-MIB sencity			
(.iso.org.dod.internet.private.enterprises.hubersuhnerOID.sencity.x / .1.3.6.1.4.1.25358.1.x)			
sencityLinkQuality	.1.	Integer	1: Green 2: Yellow 3: Red
sencityReceivePower	.10.	Integer	Receive signal level [dBm]
sencityTemperature	.11.	Integer	Temperature [°C]
sencityLockDetector	.12.	Integer	Lock detection signal level
sencityIfEthernetIn	.15.	Integer	Total frames received on the Ethernet interface over a period of 10 seconds.
sencityIfEthernetOut	.16.	Integer	Total frames sent on the Ethernet interface over a period of 10 seconds.
sencityIfEthernetInError	.17.	Integer	Total frames dropped due to errors received on the Ethernet interface over a period of 10 seconds.

Object	OID	OID type	Description
sencityIfAirIn	.18.	Integer	Total frames received on the Air interface over a period of 10 seconds.
sencityIfAirOut	.19.	Integer	Total frames sent on the Air interface over a period of 10 seconds.
sencityIfAirInError	.20.	Integer	Total frames dropped due to errors received on the Air interface over a period of 10 seconds.
sencityFirmwareversion	.21.	String	Installed firmware version
HUBERSUHNER-MIB sencitytraps			
(.iso.org.dod.internet.private.enterprises.hubersuhnerOID.sencity.sencityTraps.x / .1.3.6.1.4.1.25358.1.22.x)			
sencityLinkQualityImprovedTrap	.1.	Integer	1: from red to green 2: from red to orange 3: from orange to green
sencityLinkQualityReducedTrap	.2.	Integer	1: from green to orange 2: from green to red 3: from orange to red
sencityTemperatureHighTrap	.3.	Integer	A trap indicating that the temperature within the terminal is over or below 70 degree Celcius
sencityTemperatureLowTrap	.4.	Integer	A trap indicating that the temperature within the unit is over or below -40 degree Celcius

A TECHNICAL INFORMATION

A.1 Troubleshooting

This chapter provides solutions to problems that can occur during the installation and operation of the SL60-501. It covers various aspects of installation and network setup.

Note:

Each of the following points must be checked at both ends of the link. Start by performing the entire procedure on one side (e.g. Terminal A). If this does not solve the problem, repeat all the steps at the opposite terminal.

A.1.1 Power and network connection

You must verify that the terminal is connected to the power. The PoE injector must be installed and plugged in. Go to the terminal, disconnect the RJ-45 connector and verify if there is power in the cable using a standard PoE tester.

Take the cable and plug it into a notebook or a network testing device and verify if there is a correct network connection.

If there is any problem, please replace the cable and validate the connection again. We provide special, preassembled outdoor CAT 5e cables to ensure easy installation.

A.1.2 Network configuration

Check that the IP address is in the same range and subnet as the SL60-501.

Note:

The IP address of the SL60-501 is 192.168.0.11 for Terminal A and 192.168.0.12 for Terminal B. All the computers on the network must have a unique IP address in the same range, e.g. 192.168.0.X. Any computers with identical IP addresses will not be visible on the network.

They must all, therefore, have the same subnet mask e.g. 255.255.255.0.

Do a Ping test to make sure that the SL60-501 is responding. Go to Start → Run → Type "Command" → Type "ping 192.168.0.X".

A successful Ping test will generate four replies.

As soon as the network configuration is correct you can access the GUI (Graphical User Interface) and check the settings according to section 4.9.

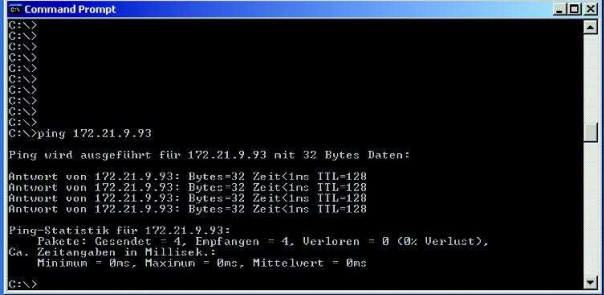

```
C:\>
C:\>
C:\>
C:\>
C:\>
C:\>
C:\>ping 172.21.9.93
Ping wird ausgeführt für 172.21.9.93 mit 32 Bytes Daten:
Antwort von 172.21.9.93: Bytes=32 Zeit<ms TTL=128
Antwort von 172.21.9.93: Bytes=32 Zeit<ms TTL=128
Antwort von 172.21.9.93: Bytes=32 Zeit<ms TTL=128
Antwort von 172.21.9.93: Bytes=32 Zeit<ms TTL=128
Ping-Statistik für 172.21.9.93:
    Pakete: Gesendet = 4, Empfangen = 4, Verloren = 0 (0% Verlust),
    Gesamtzeit in Millisek.:
        Minimum = 0ms, Maximum = 0ms, Mittelwert = 0ms
C:\>
```

A.1.3 Duplex mismatch

If you encounter bad network performance, you probably have a duplex mismatch.

To ensure that the SL60-501 terminal and the connected network component (e.g. switch) do not have a duplex mismatch you must first check your statistics.

If you find many input errors, you are on the full-duplex side; if you see many late collisions, you are on the half-duplex side.

To solve the duplex mismatch, you must manually configure both network components to the same values.

A.1.4 Miss-alignment

See the configuration interface as described in section 5.1.4. On the Radio alignment screen (see section 5.1.5) you see the signal strength in dBm (e.g. -30 dBm). If the value is below -95 dBm the receiver is not in the correct position to track the signal. You therefore need to re-align the terminal to its opposite terminal (please follow the instructions in section 4.4.1).

A.2 Specifications

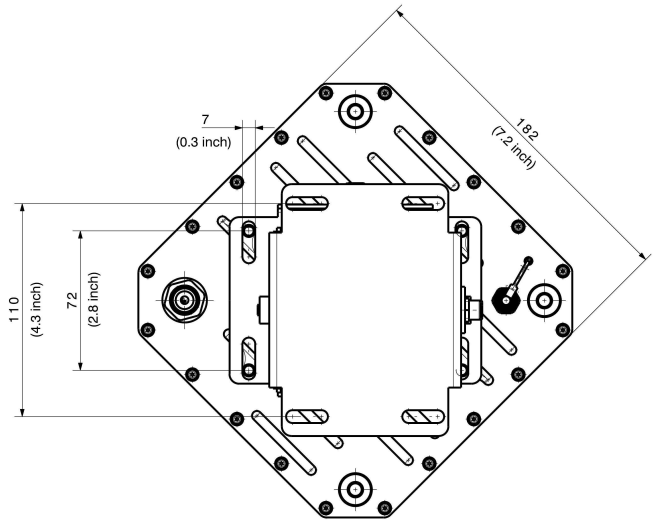
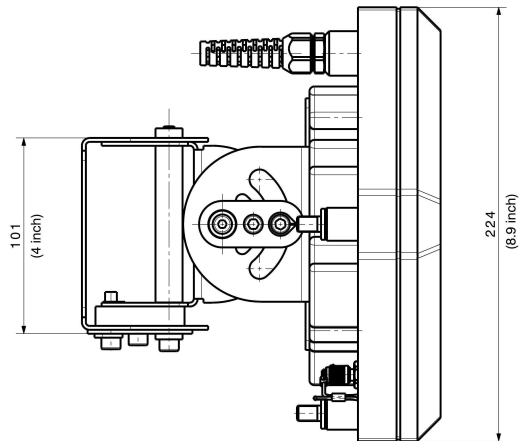
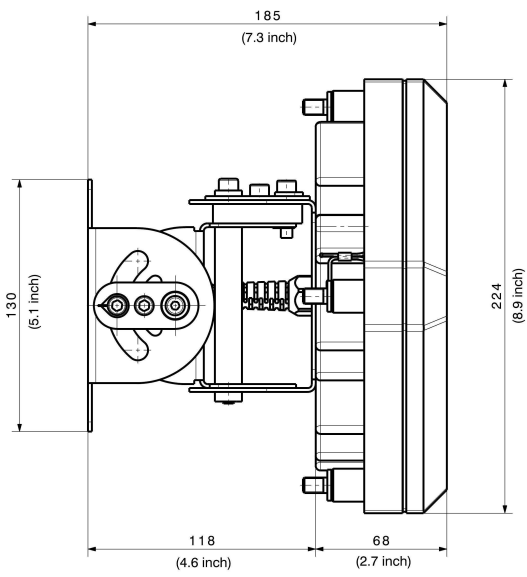

General system information

- Transmission Capacity: 100 Mbps Full Duplex
- Interface: 100 Base-TX
- Latency: < 50 μ s + distance
latency (1 μ s / 300 m)
- Range*: up to 800 m (2600 ft)
- Availability*: up to 99.999%
- Warranty: 1 year

Connection

- Cable Length: max. 100 m (300 ft)
- Signal Wires: CAT 5e
- Connector: RJ-45 (male; including outdoor Ethernet seal kit)

Mechanical data

- Dimension: 162 x 162 x 89 mm
(6.4" x 6.4" x 3.5")
- Weight: 3500 g (7.7 pounds)

System administration

- Management: SNMP
Web browser-based configuration

Power supply

- Standards: Compliant to Power over Ethernet according to IEEE 802.3af
- Voltage: \pm 48 V DC
- Power Consumption: 11 W

Environmental data

- Working Temperature **: - 45 °C ... + 55 °C
(- 49 °F ... + 131 °F)
- Storage Temperature: - 30 °C ... + 55 °C
(- 22 °F ... + 131 °F)
- Wind Load: operating 160 km/h (100 mph)

survival 200 km/h (125 mph)

Regulatory

- Regulatory Compliance:
 - FCC Part 15
 - Industry Canada RSS210
 - R&TTE Directive 1999/5/EC

Ordering information

- SL60-3001: Item # 84057630
 - SL60-4001: Item # 84064720
- each composed of:
- 2 Terminals
 - 2 Alignment brackets
 - 1 Manual
 - 2 Mounting sets
 - 1 Reset-CD
 - 2 Ice bridges

* The range depends on the climate zone and the requested availability

** Only if the terminal is powered up

A.2.1 Ethernet cable colour code

Note:
By cutting of the connector the warranty will expire.

Pin	Name	RJ45 Plug
		8 7 6 5 4 3 2 1 
1	TX+	Black
2	TX-	Green
3	RX+	Red
4	Power+	Blue
5	Power+	White
6	RX-	Orange
7	Power-	Yellow
8	Power-	Brown

Twisted pairs:

- Black / Green
- Yellow / Brown
- Red / Orange
- Blue / White

A.3 Receiver level / Rain / Link distance

The following diagram shows the approximate receiver levels at different rain rates and distances. This diagram is valid for A and B terminals delivered with firmware version 1.40.

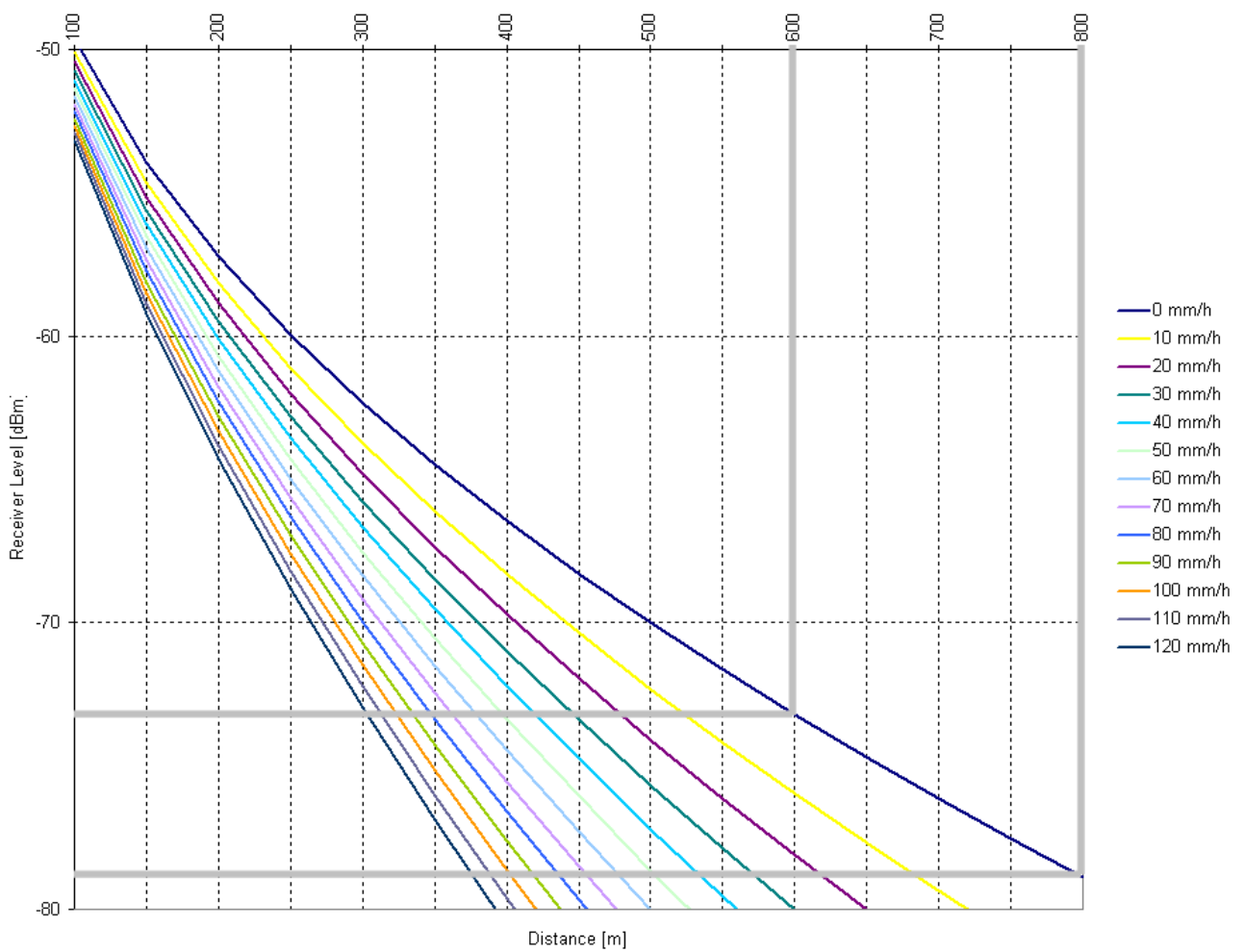

A.4 Availability / Rain zone / Link distance

The link distance is directly related to the weather conditions. The table below refers to a link working at a distance of up to 800m (SL60-501), for dry weather conditions. Please also refer to the maps in sections A.4.1, A.4.2 and A.4.3.

800m (SL60-501):

Availability	Rain zone *														
	Link distance (m)														
	A	B	C	D	E	F	G	H	J	K	L	M	N	P	Q
99%	797	789	785	764	787	770	752	765	701	772	765	741	730	669	597
99.9%	765	752	730	701	719	701	669	684	618	669	648	607	549	461	446
99.99%	701	669	648	624	607	578	569	561	549	524	473	466	405	343	376
99.999%	607	561	524	524	450	434	461	425	486	397	338	370	312	268	320

* Rain zone according to ITU-R Recommendation PN.837-1

99.9% availability equates to 526 minutes per year of outage due to heavy rains.

99.99% availability equates to 53 minutes per year of outage due to heavy rains.

99.999% availability equates to 5 minutes per year of outage due to heavy rains.

A.4.1 Map of America

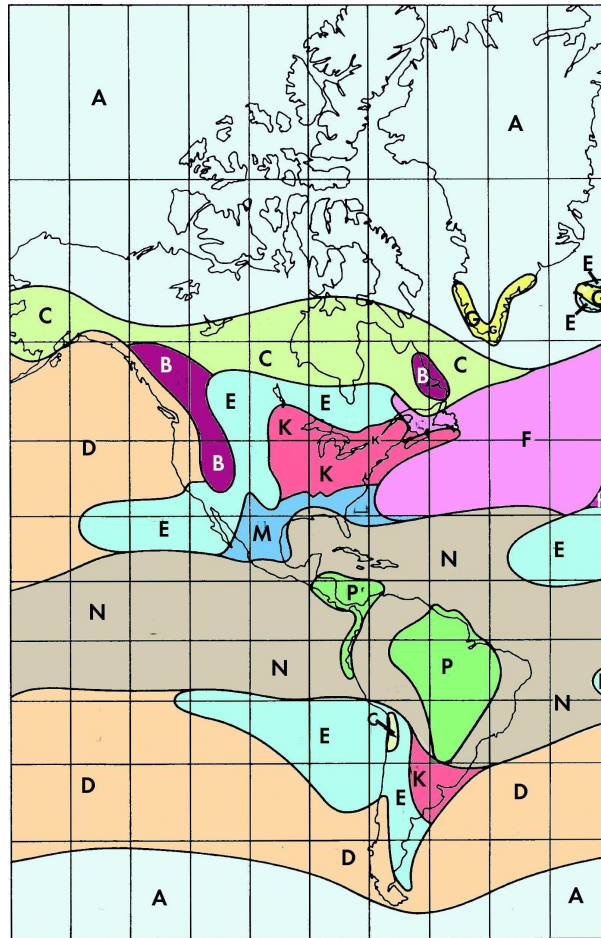

A.4.2 Map of Asia and Middle East

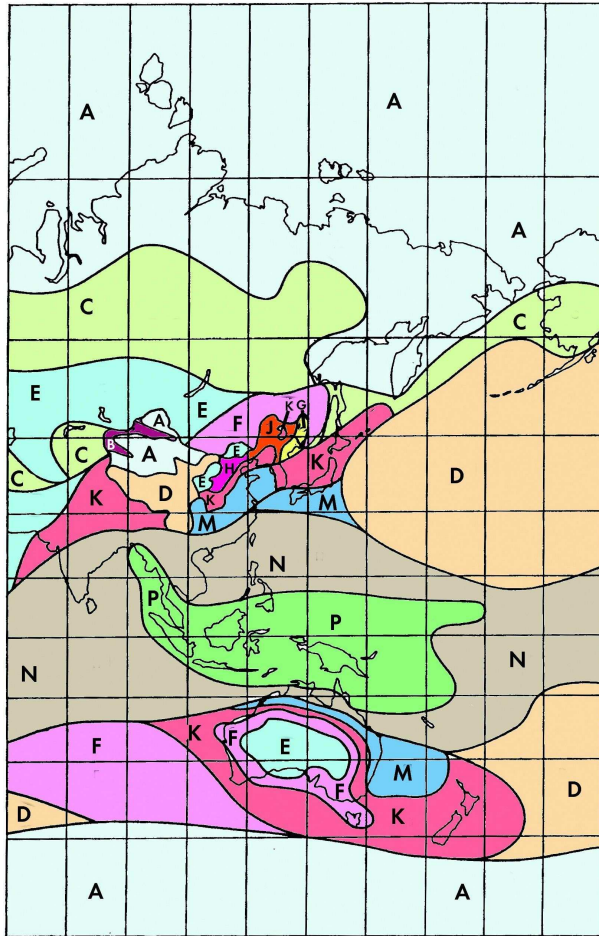

A.4.3 Map of Europe

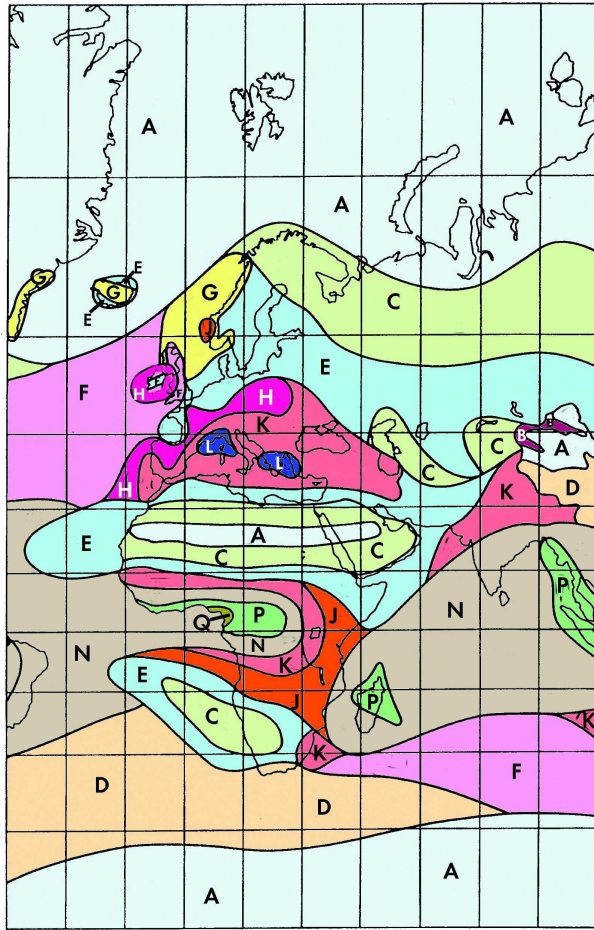

B REGULATORY INFORMATION

B.1.1 FCC statement

Changes or modifications not expressly approved by the party responsible for compliance could void the user's authority to operate the equipment.

This device complies with Part 15 of the FCC Rules.

Operation is subject to the following two conditions:

1. this device may not cause harmful interference, and
2. this device must accept any interference received, including interference that may cause undesired operation.

Note: This equipment has been tested and found to comply with the limits for a Class B digital device, pursuant to part 15 of the FCC Rules. These limits are designed to provide reasonable protection against harmful interference in a residential installation. This equipment generates, uses and can radiate radio frequency energy and, if not installed and used in accordance with the instructions, may cause harmful interference to radio communications. However, there is no guarantee that interference will not occur in a particular installation.

If this equipment does cause harmful interference to radio or television reception, which can be determined by turning the equipment off and on, the user is encouraged to try to correct the interference by one or more of the following measures:

- Reorient or relocate the receiving antenna.
- Increase the separation between the equipment and receiver.
- Connect the equipment into an outlet on a circuit different from that to which the receiver is connected.
- Consult the dealer or an experienced radio/TV technician for help.

FCC NOTICE: To comply with FCC part 15 rules in the United States, the system must be professionally installed to ensure compliance with the Part 15 certification.

It is the responsibility of the operator and professional installer to ensure that only certified systems are deployed in the United States.

The use of the system in any other combination (such as co-located antennas transmitting the same information) is expressly forbidden.

RF Exposure: This equipment complies with FCC radiation exposure limits set forth for an uncontrolled environment.

FCC ID: TTDSL60501

B.1.2 Industry Canada statement

Operation is subject to the following two conditions:

1. this device may not cause interference, and
2. this device must accept any interference, including interference that may cause undesired operation of the device.

This Class B digital apparatus complies with Canadian ICES-003.

Cet appareil numérique de la classe B est conforme à la norme NMB-003 du Canada.

This equipment complies with IC RSS-102 radiation exposure limits set forth for an uncontrolled environment.

IC: 6318A-SL60501

B.1.3 CE – Declaration of conformity

We, HUBER+SUHNER AG of Degersheimerstrasse 14, CH-9100 Herisau/Switzerland

declare that the product

SENCITY®Link / SL60-501

is in conformity – after consultation with the notified body Phoenix Testlab (No. 0700) – with the following standards and normative documents:

- EN 50371 (2002): Generic standard to demonstrate the compliance of low power electronic and electrical apparatus with the basic restrictions related to human exposure to electromagnetic fields (10 MHz - 300 GHz)
- EN 55022 (2006): Information technology equipment - Radio disturbance characteristics - Limits and methods of measurement
- EN 55024 (1998): Information technology equipment - Immunity characteristics - Limits and methods of measurement
- EN 60950-1 (2006): Information technology equipment - Safety – Part 1: General requirements
- ETSI EN 302 217-3 V1.3.1 (2009-07): Harmonized European Standard (Telecommunications series) Fixed Radio Systems; Characteristics and requirements for point-to-point equipment and antennas; Part 3: Equipment operating in frequency bands where both frequency coordinated or uncoordinated deployment might be applied; Harmonized EN covering the essential requirements of article 3.2 of the R&TTE Directive
- ETSI EN 302 217-4-2 (2007): Fixed Radio Systems; Characteristics and requirements for point-to-point equipment and antennas; Part 4-2: Harmonized EN covering essential requirements of Article 3.2 of R&TTE Directive for antennas is in accordance with the following Directives:
- R&TTE Directive 1999/5/EC

We hereby declare that the equipment named above has been designed to comply with the relevant sections of the above referenced specifications. The unit complies with all essential requirements of the Directives.

Herisau, October 2009

B.1.4 Safety

The following general safety precautions must be observed during all phases of operation and service of those products covered in this manual. Failure to comply with these precautions, or with specific warnings elsewhere in this manual, willfully violates standards of design, manufacture and the intended use of the product.

The SL60-501 meets all CE and FCC electrometric radiation safety requirements for radio equipment. However, it is advisable to avoid long-term exposure to the front face of the terminal while operating this equipment.

Outdoor equipment must be properly grounded to provide some protection against voltage surges and built-up static charges (as illustrated in chapters 4.5 and 4.6).

All electrical and mechanical installations must comply with local and/or national electrical and building codes.

This equipment must not be modified. Neither must any of its component parts be substituted.

B.1.4.1 English

Indication about the correct use of the system

The devices of this system establish a wireless point to point data connection.

Indication about possible application limitations

Operation on NIB / NPB (Non interference basis / non protection basis): The equipment is not permitted to cause harmful interference to other radio services. The equipment has to be switched off immediately in the case of

interference with other services.

Indication about the network interfaces to which the system can be connected

The devices are intended to be connected to IEEE standard 802.3af (Power over Ethernet) compliant devices. SL60-501 has to be supplied by a limited power source according to EN 60950-1:2006.

B.1.4.2 Deutsch

Hinweis auf bestimmungsgemässe Verwendung der Anlage

Die Geräte dieser Anlage stellen eine drahtlose Punkt-zu-Punkt Datenverbindung her.

Hinweis auf mögliche Verwendungseinschränkungen

Interferenzen und Schutzvorkehrungen im Betrieb: Die Ausrüstung ist nicht gestattet, andere Funkdienste nachteilig zu stören. Das Gerät muss im Falle von Interferenzen mit anderen Diensten sofort ausgeschaltet werden.

Hinweis auf die Netzschnittstellen, an welche die Anlage angeschlossen werden kann

Die Geräte sind für den Anschluss an dem IEEE-Standard 802.3af (Power over Ethernet) konforme Geräte bestimmt. SL60-501 muss durch eine Stromquelle begrenzter Leistung gemäss EN 60950-1:2006 gespeisen werden.

B.1.4.3 Français

Indication concernant l'utilisation correcte de l'installation

L'équipement de cette installation établis une liaison de données point à point sans fil.

Indication concernant de possible restrictions de l'utilisation

Interférence et protection pendant le fonctionnement: Le matériel n'est pas permis de causer des interférences nuisibles à d'autres services radio. Le matériel doit être mis hors service immédiatement dans le cas d'interférence avec d'autres services.

Indication concernant les interfaces du réseau auxquelles l'installation peut être raccordé

L'équipement est conçu pour le raccordement aux appareils conformes au standard IEEE 802.3af (Power over Ethernet). SL60-501 doit être alimenté par une source de courant fini selon EN 60950-1:2006.

B.1.4.4 Italiano

Indicazione concernente l'utilizzo corretto e l'installazione

Le componenti installate di questo sistema creano un ponte radio punto-punto.

Indicazione concernente le possibili restrizioni dell'utilizzo

Interferenze e protezione durante l'utilizzo: il sistema non deve causare alcuna interferenza nociva ad altri servizi radio. Questo sistema deve essere spento immediatamente nel caso di interferenza con altri servizi.

Indicazione concernente le interfacce alle quali il sistema può essere connesso

Il sistema è concepito per essere connesso all'interfaccia conforme allo standard IEEE 802.3af (Power over Ethernet). SL60-501 deve essere alimentato da un'alimentazione conforme alle specifica EN 60950-1:2006.

C CONTACTS

C.1.1 Technical assistance

Please visit <http://www.hubersuhner.com/sl60>

C.1.2 Service center / RMA

USA / Canada toll free phone number:
1-800-348-9008

D GLOSSARY

BPSK	Binary Phase Shift Keying		
DHCP	Dynamic Host Configuration Protocol DHCP enables both manual and automatic IP address allocation in a network.	QPSK	Quadrature Phase Shift Keying
		SNMP	Simple Network Management Protocol
		TCP	Transmission Control Protocol
DNS	Domain Name System enables the translation from IP address to domain name	WAN	Wide Area Network
		WLAN	Wireless Local Area Network. This typically unlicensed non line of site application operates in the frequency range 2 - 6 GHz according to IEEE 802.11x.
CE	The CE marking is a conformity mark on products placed on market in the European Economic Area.		
FCC	Federal Communication Commission (USA)		
IP	Internet Protocol		
LAN	Local Area Networks		
LOS	Line of Sight – uninterrupted, visual, point-to-point contact.		
MAC address	Media Access Control physical, unique address of network component		
OSHA	Occupational Safety and Health Administration		
PoE	Power over Ethernet according to IEEE 802.3af that provides for a		

HUBER+SUHNER (Australia) Pty. Ltd.
Unit 6, 4 Skyline Place
Frenchs Forest
Sydney NSW 2086 (Australia)
Telefon: +61 2 8977 1200
E-Mail: webenq.au@hubersuhner.com

HUBER+SUHNER América Latina Ltda.
Avenida Rui Barbosa, 3613
Alto da Ponte
Sao José dos Campos -
SP 12213 300 (Brazil)
Telefon: +55 12 3946 9 500
E-Mail: info.br@hubersuhner.com

HUBER+SUHNER (Canada) Ltd.
2650 Queensview Drive
Suite 206
Ottawa ON K2B 8H6 (Canada)
Telefon: +1 613 721 4111
E-Mail: info@hubersuhner.ca

HUBER+SUHNER AG
Degersheimerstrasse 14
Postfach
9100 Herisau (Switzerland)
Telefon: +41 71 353 4111
E-Mail: info@hubersuhner.com

HUBER+SUHNER GmbH
Mehlbeerenstrasse 6
Postfach 1263
82019 Taufkirchen (Germany)
Telefon: +49 89 6 12 01-0
E-Mail: info.de@hubersuhner.com

HUBER+SUHNER A/S
Kirke Værløsevej 14
3500 Værløse (Denmark)
Telefon: +45 48 100 500
E-Mail: info@hubersuhner.dk

HUBER + SUHNER France
21 E, rue Jacques CARTIER
78960 Voisins le Bretonneux (France)
Telefon: +33 1 61 37 25 55
E-Mail: info.fr@hubersuhner.com

HUBER+SUHNER (Hong Kong) Ltd.
Suite 1601, 16/F
Chung Nam Building
1 Lockhart Road
Wanchai, Hong Kong (China)
Telefon: +852 2866 6600
E-Mail: webenq.hk@hubersuhner.com

HUBER+SUHNER Electronics Pvt. Ltd.
359, Udyog Vihar, Phase II
Gurgaon 122016
Haryana (India)
Telefon: +91 124 5102701/02/03
E-Mail: info.in@hubersuhner.com

HUBER+SUHNER AB
Knarrarnäsgatan 7
Box 1247
SE 164 28 Kista, Stockholm (Sweden)
Telefon: +46 8 447 5200
E-Mail: info.se@hubersuhner.com

HUBER+SUHNER (Singapore) Pte. Ltd.
Number 8, Tuas Avenue 5
Singapore 639334 (Singapore)
Telefon: +65 6861 8186
E-Mail: webenq.sg@hubersuhner.com

HUBER+SUHNER (UK) Ltd.
Telford Road
Bicester Oxfordshire OX26 4LA (UK)
Telefon: +44 1869 364 100/101
E-Mail: info.uk@hubersuhner.com

HUBER+SUHNER Inc.
19 Thompson Drive
Essex VT 05452 (USA)
Telefon: +1 802 878 0555
E-Mail: info.us@hubersuhner.com

HUBER+SUHNER is certified according to
ISO 9001, ISO 14001, ISO/TS 16949 and IRIS.

WAIVER

It is exclusively in written agreements that we provide our customers with warrants and representations as to the technical specifications and/or the fitness for any particular purpose. The facts and figures contained herein are carefully compiled to the best of our knowledge, but they are intended for general informational purposes only.

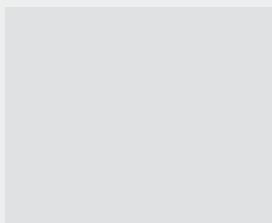

HUBER+SUHNER AG
Radio Frequency Division
Degersheimerstrasse 14
9100 Herisau/Switzerland
Tel. +41 71 353 41 11
Fax +41 71 353 45 90
info@hubersuhner.com

84023368

hubersuhner.com

