

INSTALLATION AND USER MANUAL

SL60-6004

Revision B



We, HUBER+SUHNER AG of Degersheimerstrasse 14, CH-9100 Herisau/Switzerland
declare that the product
SENCITY@Link / SL60-6004

is in conformity – after consultation with the notified body Cetecom (No. 0682) – with the following
standards and normative documents:

- EN 50371 (2002): Generic standard to demonstrate the compliance of low power electronic and electrical apparatus with the basic restrictions related to human exposure to electromagnetic fields (10 MHz - 300 GHz)
- EN 55022 (2006): Information technology equipment - Radio disturbance characteristics - Limits and methods of measurement
- EN 55024 (1998): Information technology equipment - Immunity characteristics - Limits and methods of measurement
- EN 60950-1 (2006): Information technology equipment - Safety -- Part 1: General requirements
- ETSI EN 302 217-3 (2007): Fixed Radio Systems; Characteristics and requirements for point-to-point equipment and antennas; Part 3: Harmonized EN covering essential requirements of Article 3.2 of R&TTE Directive for equipment operating in frequency bands where simplified or no frequency co-ordination procedures are applied
- ETSI EN 302 217-4-2 (2007): Fixed Radio Systems; Characteristics and requirements for point-to-point equipment and antennas; Part 4-2: Harmonized EN covering essential requirements of Article 3.2 of R&TTE Directive for antennas is in accordance with the following Directives:
 - R&TTE Directive 1999/5/EC

We hereby declare that the equipment named above has been designed to comply with the relevant sections of the above referenced specifications. The unit complies with all essential requirements of the Directives.

Herisau, February 2008

This device complies with part 15 of the FCC rules and with RSS-210 of Industry Canada. Operation is subject to the following two conditions:

1. This device may not cause harmful interference.
2. This device must accept any interference received, including interference that may cause undesired operation.

If this product is suspected of causing harmful interference with other equipment, discontinue its operation immediately and contact HUBER+SUHNER.

In order to meet FCC RF Exposure requirements, this device must be installed in such a way that a distance of 2 m is always maintained between the device antenna and nearby persons.

Modifications or substitutions made on the terminal or parts of it without the written approval of HUBER+SUHNER could void the user's authority to operate the equipment.

FCCID: TTDSL606004

IC: 6318A-SL606004

Note: This equipment has been tested and found to comply with the limits for a Class B digital device, pursuant to Part 15 of the FCC Rules. These limits are designed to provide reasonable protection against harmful interference in a residential installation. This equipment generates, uses and can radiate radio frequency energy and, if not installed and used in accordance with the instructions, may cause harmful interference to radio communications. However, there is no guarantee that interference will not occur in a particular installation. If this equipment does cause harmful interference to radio or television reception, which can be determined by turning the equipment off and on, the user is encouraged to try to correct the interference by one or more of the following measures:

- Reorient or relocate the receiving antenna.
- Increase the separation between the equipment and receiver.
- Connect the equipment into an outlet on a circuit different from that to which the receiver is connected.
- Consult the dealer or an experienced radio/TV technician for help.

Caution: Use only the A.C. power cord supplied for this product. Use of other may not ensure compliance with FCC rule.

TABLE OF CONTENTS

1 Introduction	7	3.4.1 Wall mounting	18
1.1 Intended users	7	3.4.2 Pole mounting	19
1.2 Revision	7	3.5 Cabling	19
1.3 Prior knowledge	7	3.6 Grounding / Lightning protection	20
1.4 Organisation	7	3.7 Co-located applications	20
1.5 Used symbols	8	4 Installation	21
1.6 Safety	9	4.1 Unpacking	21
1.7 Warranty	9	4.2 Mount installation	22
1.8 Copyright / Disclaimer	10	4.2.1 Wall mount	22
2 System overview	11	4.2.2 Mast mount	23
2.1 General description	11	4.3 Terminal installation	24
2.1.1 Benefits	11	4.4 Cable installation	24
2.1.2 Applications	12	4.5 Antenna alignment	25
2.2 System components	12	4.5.1 Alignment Procedure	26
2.2.1 Terminals	13	4.5.1.1 Step 1: Optical alignment	26
2.2.2 Alignment bracket	13	4.5.1.2 Step 2: Power level alignment	27
2.2.3 Alignment tool	13	4.6 Grounding	28
2.2.4 Ice bridge	14	4.7 Lightning / Surge protector	28
2.2.5 Sealed Ethernet connector	14	4.8 Power injector	29
2.2.6 Accessories	14	5 Terminal management and monitoring functions	30
2.2.6.1 PoE injector (accessory)	14	5.1 Web browser interface	31
2.2.6.2 Data line protector (accessory)	15	5.1.1 System overview screen	31
2.2.6.3 Mast bracket (accessory)	15	5.1.1.1 Traffic light colors	31
2.2.6.4 Ethernet cables (accessory)	15	5.1.2 Password screen	31
3 Site planning	16	5.1.3 Firmware update screen	32
3.1 Terminal location	17	5.1.4 Network configuration screen	32
3.2 Line of sight	17	5.1.5 Radio alignment screen	33
3.3 Link distance / Link availability	18	5.1.6 Network statistics screen	33
3.4 Terminal mounting options	18	5.1.7 SNMP configuration screen	33

5.1.8 VLAN configuration screen	34	A.4.1 Map of America	46
5.2 SNMP interface	35	A.4.2 Map of Asia and Middle East	48
5.3 Reset-CD	36	A.4.3 Map of Europe	50
5.3.1 Parameter reset	37	A.5 Accessories order information	52
5.3.2 Firmware upload	37	B Country specific information	56
A Technical information	38	B.1.1 Switzerland, Germany	56
A.1 Troubleshooting	38	B.1.1.1 English	56
A.1.1 Power and network connection	38	B.1.1.2 Deutsch	56
A.1.2 Network configuration	38	B.1.1.3 Français	57
A.1.3 Duplex mismatch	39	B.1.1.4 Italiano	57
A.1.4 Miss-alignment	39	C Contacts	58
A.2 Specifications	41	C.1.1 Technical assistance	58
A.2.1 Ethernet cable colour code	44	C.1.2 Service center / RMA	58
A.3 Receiver level / Rain / Link distance	45	D Glossary	59
A.4 Availability / Rain zone / Link distance	46	E Notes	60

1 INTRODUCTION

1.1 INTENDED USERS

This manual is intended for all installation and service personnel who are involved in the planning, installation, operation and maintenance of SL60-6004 equipment.

Please read the complete SL60-6004 (SENCITY®Link) manual prior to its unpacking, installation, setup and deployment.

Although the SENCITY®Link is designed for easy installation and setup, optimum performance can be achieved by following the procedures outlined in this manual.

1.2 REVISION

HUBER+SUHNER reserves the right to revise this documentation periodically without any obligation to provide notification of such revision or changes. The latest revision can be downloaded on <http://www.hubersuhner.com/sl60>.

1.3 PRIOR KNOWLEDGE

This manual assumes that the installer has at least a basic experience and understanding of networking equipment, as well as some familiarity with its configuration and operation. The information covered in this manual should be fully understood prior to installation.

1.4 ORGANISATION

This user manual is organised into chapters as follows:

- Chapter 1: Introduction – Describes general and legal information.
- Chapter 2: System overview – Contains the technical data and the description of the equipments.

- Chapter 3: Site planning – Summarizes the requirements regarding site and network. This chapter has to be read as preparation for the installation.
- Chapter 4: Installation – Describes the recommended installation procedure of the terminal.
- Chapter 5: Management and monitoring functions
- Appendix A: Presents additional useful technical information like: troubleshooting, weather maps and technical data.
- Appendix B: Country specific information
- Appendix C: Contacts
- Appendix D: Glossary – Helps with the most important abbreviations.

1.5 USED SYMBOLS

Danger

Not used

Warning

Risk for human and equipment

Caution

Risk for equipment and functionality

Advice

1.6 SAFETY

The following general safety precautions must be observed during all phases of operation and service of those products covered in this manual. Failure to comply with these precautions, or with specific warnings elsewhere in this manual, willfully violates standards of design, manufacture and the intended use of the product.

The SL60-6004 meets all CE and FCC electrometric radiation safety requirements for radio equipment. However, it is advisable to avoid long-term exposure to the front face of the terminal while operating this equipment.

Outdoor equipment must be properly grounded to provide some protection against voltage surges and built-up static charges (as illustrated in chapters 4.6 and 4.7).

All electrical and mechanical installations must comply with local and/or national electrical and building codes.

This equipment must not be modified. Neither must any of its component parts be substituted.

1.7 WARRANTY

HUBER+SUHNER warrants to the original end user (purchaser) that this product is free from any defects in materials or workmanship for a period of up to one year from the date of shipment to the end user. During the warranty period, and upon proof of purchase, should the product show indications of failure due to faulty workmanship and/or materials, HUBER+SUHNER will, at its discretion, repair or replace the defective products or components without charge for either parts or labor, and to whatever extent it shall deem necessary to restore the product or components to full operating condition. Any replacement will consist of a

new or remanufactured, functionally equivalent product of equal value, and will be offered solely at the discretion of HUBER+SUHNER.

This warranty shall not apply if the product is modified (e.g. warranty seal is broken), misused, tampered with, damaged by an act of God, or subjected to abnormal working conditions.

To obtain services under this warranty, contact HUBER+SUHNER's Service Center, referring to your Return Material Authorization number (see C.1.2). Products must be returned Postage Prepaid. It is recommended that the terminal be insured when shipped. Any products returned without either proof of purchase or with an outdated warranty will be repaired or replaced and the customer will be billed for parts and labor. All repaired or replaced products will be shipped by HUBER+SUHNER to the corresponding return address 'Postage Paid' (USA only). If the customer specifies some other return destination beyond US borders, the customer shall bear the cost of the return shipment. This warranty gives you specific legal rights, and you may also have other rights that vary from state to state.

1.8 COPYRIGHT / DISCLAIMER

Copyright © 2009 by HUBER+SUHNER

The contents of this publication may not be reproduced in any part or as a whole, transcribed, stored in a retrieval system, translated into any language, or transmitted in any form or by any means, electronic, mechanical, magnetic, optical, chemical, photocopying, manual, or otherwise, without the prior written permission of HUBER+SUHNER.

2 SYSTEM OVERVIEW

2.1 GENERAL DESCRIPTION

The SL60-6004 system operates as a data link in the unlicensed 60 GHz band between 57 GHz and 64 GHz and delivers a full duplex data rate of 100 Mbps over a distance of up to 1200 m (3930 ft). Measuring 34 cm x 34 cm (13.4" x 13.4"), the terminal's compact size is attained by extensively integrating the active and passive components.

For more detailed technical data see appendix A.2.



2.1.1 Benefits

- Easy installation – The concept of the SENCITY®Link allows to the end user to install it as easy as any other network component. The single cable solution reduces the complexity of the installation. The terminal is connected to the network, monitored and supplied with power through a single outdoor rated CAT 5e Ethernet cable. The visual alignment tool and an alignment bracket allows the user to easily install the link. Immediate operation without the need of additional configuration is granted.
- Network performance – Guaranteed full duplex 100 Mbps along the complete range. Unlike typical

System architecture

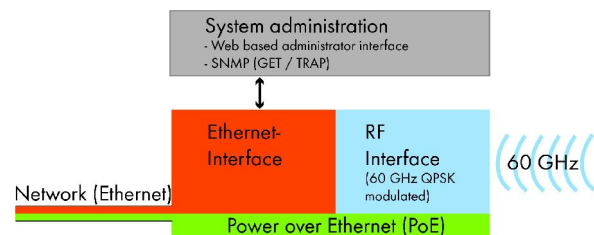

WLAN equipment the user can transmit a full 100 Mbps over the link.

- License free operation – The system has been approved and can be operated in many countries.
- System administration – To monitor the status and the traffic the user can access the link statistics either via the HTML user interface or by integrating it into a network management tool via SNMP.
- Security – The proprietary radio interface does not allow any other system to access the 60 GHz transmitted data.

A high level of data security is inherent in the product via signal absorption by atmospheric oxygen and the use of high gain/narrow beam width antennas.

2.1.2 Applications

- LAN extension
- Redundant access
- Campus connectivity
- Disaster recovery
- Wireless backhaul
- Centralization of IT infrastructure
- Temporary connections during events
- Mesh and hub and spoke configuration

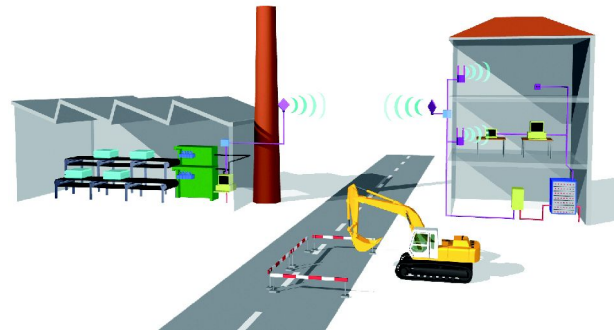

2.2 SYSTEM COMPONENTS

The SL60-6004 system is composed of the following components:

- Terminal A and Terminal B
- Alignment bracket
- Alignment tool
- Ice bridge
- Sealed Ethernet connection
- Main accessories:
 - PoE injector
 - Lightning protector
 - Mast bracket
 - Ethernet cables

2.2.1 Terminals

The terminals are the main system components. They combine the antenna, transmitter and receiver and are connected to the network via a standard Ethernet cable with RJ-45 connector.

Power is supplied through the Ethernet cable to the terminal. This will require either a PoE (802.3af) compatible network equipment or an additional PoE injector.



2.2.2 Alignment bracket

The alignment bracket facilitates installation and positioning owing to its independent axis with coarse and fine alignment capabilities.



2.2.3 Alignment tool

The optical alignment tool provided is easily mounted on the terminal. It enables both ends of the link to be aligned quickly, simply and independently.



2.2.4 Ice bridge

The ice bridge offers an additional protection for the terminal against rain, snow and ice-formation.



2.2.5 Sealed Ethernet connector

The seal kit is used to make a watertight connection of the Ethernet coupling. Please use the separate instructions for a proper installation of the seal kit.



2.2.6 Accessories

Please also refer to section A.5.

2.2.6.1 PoE injector (accessory)

The terminal is powered via Ethernet cable according to the IEEE 802.3af PoE standard. Should the network equipment connected to the SENCITY®Link does not offer PoE, a power injector can be inserted in line to the Ethernet cable.



2.2.6.2 Data line protector (accessory)

HUBER+SUHNER strongly recommends the installation of an outdoor data line protector to provide lightning and surge protection for the building, personnel and equipment. Please refer to the local and/or national electrical and building codes.



Outdoor



Indoor

2.2.6.3 Mast bracket (accessory)

The mast bracket is used to mount the bracket onto a mast. The bracket is suitable for any pole diameter from 50 mm to 115 mm (2" to 4,5").

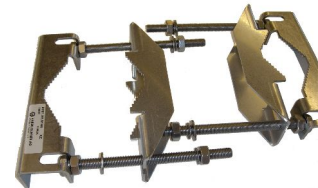

2.2.6.4 Ethernet cables (accessory)

The length of the cable linking the SENCITY®Link to the next network node may be up to 100 m (328 ft) in length. It should, however, be kept as short as practical in order to minimize signal losses. All Ethernet cables must be CAT 5e compliant and suitable for outdoor use. The cable must be UV stable, UL approved and comply with local and/or national building codes.



3 SITE PLANNING

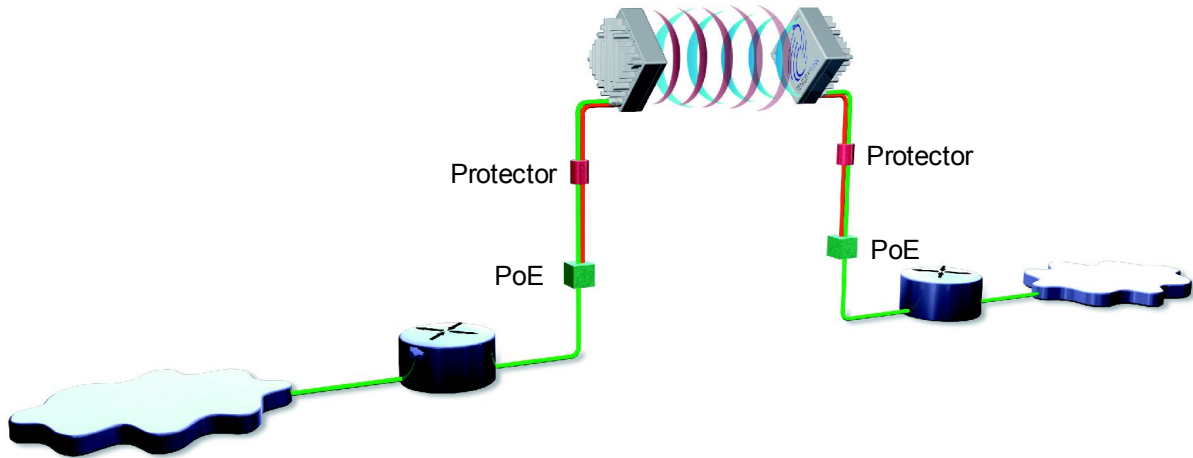

All installers must perform a full site inspection and plan carefully prior to the physical installation of an SL60-6004 system.

This preparation must include:

- Evaluating the most appropriate location for the installation of the terminal.
- Identifying an appropriate mounting structure (wall or mast) for each terminal.
- Planning the cable routing from the network component to the terminal.

3.1 TERMINAL LOCATION

When selecting the best terminal location the following factors should be considered:

- Accessibility (e.g. roof)
- Type of mounting (e.g. wall or pole)
- Grounding connection point
- Cable runs (max. 100 m / 328 ft)
- Line of sight

Use of given protection against sun, rain, etc. will increase the equipment performance.

3.2 LINE OF SIGHT

To ensure a clear line of sight, there must be no obstructions between the two terminal locations. The required clearance can be established visually using the following table¹:

Link distance	Boundary diameter
100 m (328 ft)	0.7 m (2.3 ft)
200 m (656 ft)	1.0 m (3.3 ft)
400 m (1312 ft)	1.4 m (4.6 ft)
600 m (1968 ft)	1.7 m (5.6 ft)
800 m (2625 ft)	2.0 m (6.6 ft)
1000m (3281 ft)	2.2 m (7.3 ft)
1200m (3937 ft)	2.4 m (8.0 ft)

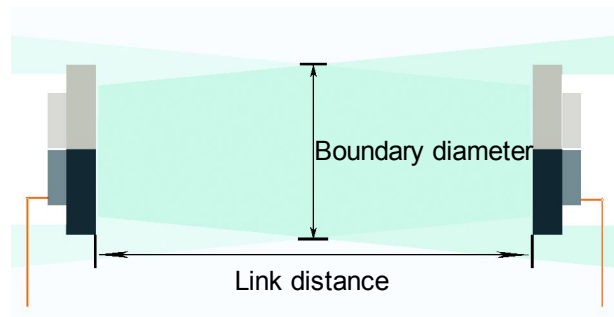

¹ Fresnel zone calculation

3.3 LINK DISTANCE / LINK AVAILABILITY

The link distance is directly related to the weather conditions.

The affordable link availability is influenced by the following environmental conditions:

- Rain the less, the better
- Temperature the higher, the better
- Air pressure the lower, the better

Knowledge of the link distance (line of sight) is important in estimating link quality.

For different maps of the world including the rain regions see appendix A.4.

For a more accurate link distance vs. availability calculation please visit <http://www.hubersuhner.com/sl60> where you will find an online calculation tool.

3.4 TERMINAL MOUNTING OPTIONS

3.4.1 Wall mounting

The wall mounting location should be strong enough to secure the terminal to the wall, taking into account all foreseeable environmental conditions (e.g. wind, rain, ice).

Depending on the material to which the bracket is mounted, differently sized mounting hardware may be necessary.

To mount the terminal onto the bracket use the enclosed M6 bolts. The bracket allows a tilt angle of $\pm 50^\circ$ in both axis.

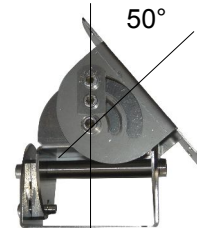

3.4.2 Pole mounting

The pole mounting kit will be needed to mount the terminal onto poles with diameters from 50 mm to 115 mm (2" to 4,5").

3.5 CABLING

The terminal is delivered with an Ethernet cable terminated with a RJ-45 plug connector. To connect the SENCITY®Link to your network, use a CAT 5e Ethernet cable with a maximum length of 100 m to the next network node. Please verify too that the cable used is designed for outdoor environments (e.g. water, solar UV). Since the power is supplied by the Ethernet cable, please make sure that network equipment used supports Power over Ethernet (PoE). If not, use a PoE injector according to IEEE 802.3af. SENCITY®Link can handle crossover and straight cables.

3.6 GROUNDING / LIGHTNING PROTECTION

The terminal must be properly grounded to provide protection against voltage surges.

In the event of a short circuit or lightning strike, effective grounding can prevent damage to building, equipment, infrastructure and personnel. For installations in the USA, refer to Article 830 of the National Electrical Code (Network-powered broadband communications systems), for all other countries, implement protection in accordance with the safety standards and regulatory requirements of the country in which the equipment is installed.

HUBER+SUHNER strongly recommends the use of outdoor lightning protectors.

3.7 CO-LOCATED APPLICATIONS

Owing to the compact size of the SL60-6004 integrated terminal, it is particularly suitable for co-sited applications. Possible configurations include:

- Back-to-back - e.g. doubles the link distance
- Parallel link - doubles data capacity or redundancy
- Star - hub and spoke

To deploy a co-sited application, please contact HUBER+SUHNER to assist with devising an appropriate site design.

4 INSTALLATION

Owing to the small size and integrated design of the SENCITY®Link, its correct installation and setup is relatively simple.

Nevertheless, when working on a roof, ladder, mast or staging, please take extreme care, observing all facility and OSHA (or other applicable regulatory agency) required safety precautions.

4.1 UNPACKING

All equipment and installation material is packed into one box. This is divided into three cartons containing the following items:

- Carton A:
 - Terminal A
 - Bracket
 - Mounting set
- Carton B:
 - Terminal B
 - Bracket
 - Mounting set
- Carton C:
 - Manual
 - Reset-CD
 - Ice bridges
 - Accessories
- Required tools:
 - Adjustable-end wrench

4.2 MOUNT INSTALLATION

4.2.1 Wall mount

The wall and mounting screws must be able to support a weight of 16.5 pounds (7.5 kg), taking into account associated wind and potential ice loading factors.

To ensure the use of the correct screws for the installation, HUBER+SUHNER recommends consulting HILTI's online Anchor System Advisor at http://www.us.hilti.com/holus/modules/adansel/adas_oview.jsp



Right

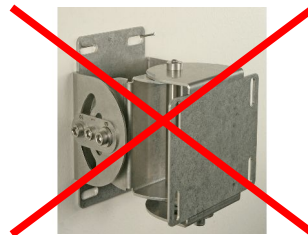

Wrong

4.2.2 Mast mount

- Ensure that the mast used has a diameter of between 50 mm to 115 mm (2" to 4.5").
- Use a 13 mm flat wrench (~1/2") to fasten the M8 screw nut.
- Fasten the alignment bracket onto front part of mast bracket using the enclosed stainless steel screws, nuts and washer (M6).
- Fix the front part of the mast bracket and the attached alignment bracket on the mast.

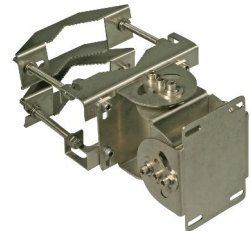
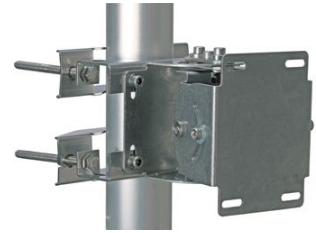

Do not use zinc plated screws as these will corrode and endanger link performance and environment.

4.3 TERMINAL INSTALLATION

It is important to install the terminal on the bracket with the same orientation (i.e. antenna polarization) at both ends of the link. The terminal must be mounted on the bracket in such a way that the cable enters it on the same side, top or bottom. The terminal must be mounted on the bracket by using the allen key with the enclosed stainless steel screws (M6 x 12).

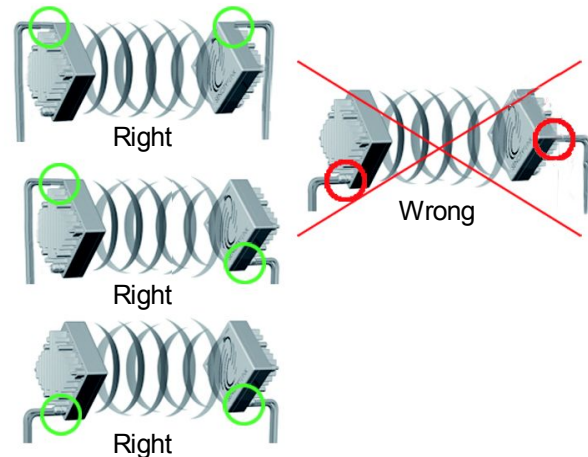

Do not use zinc plated screws as these will corrode and endanger link performance and environment.

Positioning the terminal with lateral cable entry will influence heat dissipation.

4.4 CABLE INSTALLATION

The length of the cable from the terminal to the next network component may be up to 100 m (328 ft) in length, but should be kept as short as practical in order to reduce signal loss. All Ethernet cables must be CAT 5e compliant and suitable for outdoor use. The cable must be UV stable, UL approved and must comply with local and/or national building codes.



To enter the building, HUBER+SUHNER recommends using cable seals from Roptec (<http://www.roptec.com>).

4.5 ANTENNA ALIGNMENT

One of SENCITY@Link's biggest advantage is its fast, easy alignment procedure. The terminals can be aligned optically by using the alignment tool. No electrical alignment is required, although possible.

The table below shows the alignment tolerance:

Link distance		Alignment accuracy	
500 m	1640 ft	3.1 m	10.3 ft
800 m	2625 ft	5.0 m	16.5 ft
1200m	3937 ft	7.5 m	24.7 ft

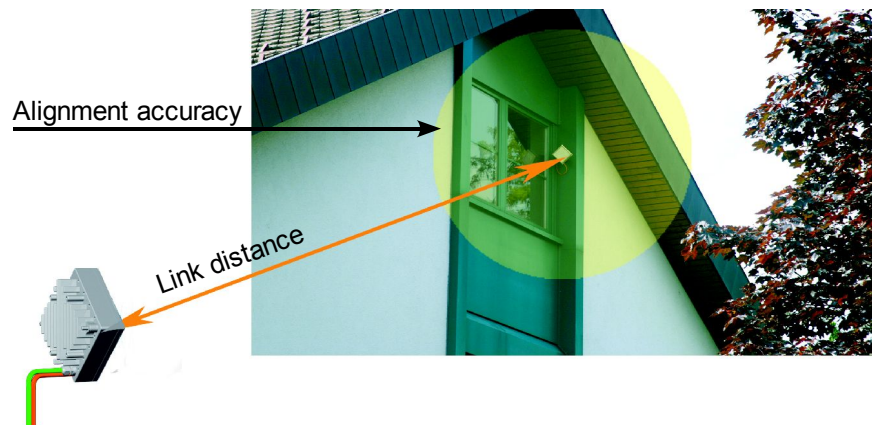

4.5.1 Alignment Procedure

The following procedure achieves fast, accurate alignment (for all mechanical operations, the enclosed 5 mm allen key can be used). Follow the two alignment steps for both, the A and B terminal.

4.5.1.1 Step 1: Optical alignment

- a) Place the alignment tool to the most accessible edge and ensure good visibility to the opposite terminal by rotating the telescope.



- b) Loosen the horizontal lock screws (labeled “3” and “4”)

- c) Place the horizontal axis course screw in its middle position (needle).

- d) Carry out a rough alignment on the horizontal axis and fasten the screw (labeled “1”).

Horizontal alignment

Wall

Vertical alignment

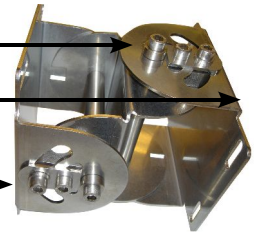

- e) Repeat steps b), c) and d) for the vertical axis.
- f) Turn the horizontal course screw (labeled “2”) by viewing through the telescope and carry out the fine alignment.
- g) Repeat f) for the vertical axis.

2 Fine alignment

1 Coarse alignment

3 First lock

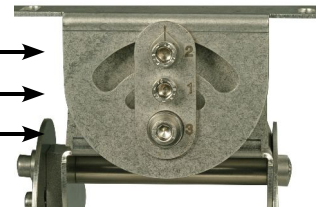

- h) If necessary, repeat the fine alignment procedure f) for both axes until the opposite link is correctly aligned.
- i) Fasten the lock screws (labeled “3” and “4”) on both horizontal and vertical axes.

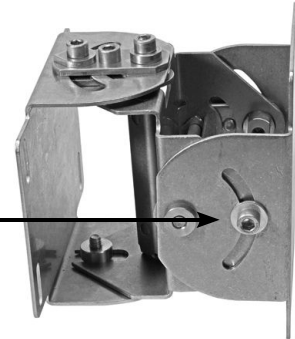

4 Second lock

4.5.1.2 Step 2: Power level alignment

Since SL60-6004 has a very narrow beam width, in most cases the optical alignment as described in section 4.5.1.1 will not be accurate enough for a proper working of the link.

It is therefore strongly recommended to proceed with an alignment based on the receiver power level on each terminal. The power level can be accessed via the web interface (see section 5.1.5). If possible, use the screws labeled “2” only for the power level alignment. Do not forget to loosen (respectively tighten) the two lock screws before (respectively afterwards).

See chapter A.3 for an estimation of the power levels at different rain rates and link distances.

A power level of -60dBm is better than a power level of -70dBm

4.6 GROUNDING

The terminal must be properly grounded.

Two screws are provided on the reverse housing of the terminal to facilitate the correct grounding. To fasten the grounding cable onto the terminal, use a lug and serrated washer combined with an M8 nut. Connect the terminal to the connection points nearest to the building-to-earth ground point. The grounding conductor must be as short as is practical and should not exceed 6 m (20 ft). For installations in the USA, refer to Articles 830 of the National Electrical Code (Network-powered broadband communications systems). For installations in all other countries, refer to the safety standards and regulatory requirements.

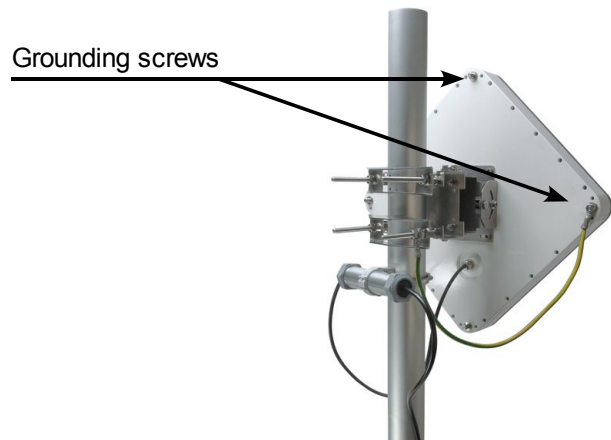

4.7 LIGHTNING / SURGE PROTECTOR

HUBER+SUHNER strongly recommends the use of outdoor data line protectors.

To protect humans and the building a protector must be installed before the cable enters the building. For detailed installation instructions, please refer to the dedicated documents enclosed to the protectors:

Outdoor protector 3414.99.0008 84016716

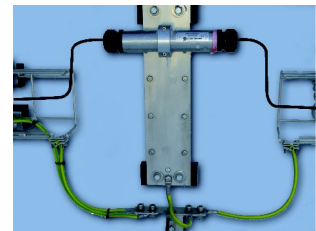

4.8 POWER INJECTOR

The power injector is connected inline into the data line. The maximum distance between the PoE and the SENCITY®Link is 100 m (328 ft). The PoE must be IEEE 802.3af compliant. To check that the injector is functioning correctly, use the PoE Tester (see accessories order information in section A.5).



5 TERMINAL MANAGEMENT AND MONITORING FUNCTIONS

For an initial configuration, use a PC or laptop. Address the terminal with the appropriate IP address.

Every terminal is labeled with its terminal type (A or B).

The factory default values are:

Terminal	IP address	Subnet mask	User name	Password
A	192.168.0.11	255.255.255.0	admin	sl60
B	192.168.0.12	255.255.255.0	admin	sl60

To communicate with the terminal, ensure that the IP address of the computer used is not allocated automatically by the DHCP server. Configure the IP address manually - e.g. 192.168.0.1 with subnet mask 255.255.255.0. Remember to ensure that your web browser is not using any proxy server settings.

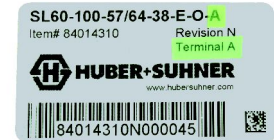

Note:

The IP address settings have no influence on data connectivity. This settings are only needed to access the terminal monitoring functions of the terminal.

5.1 WEB BROWSER INTERFACE

5.1.1 System overview screen

This screen shows an overview of key link information including its current status.

5.1.1.1 Traffic light colors

Green: System is working correctly
Yellow: System is working with intermittent detection and synchronization
Red: System is not functional

The screenshot shows the 'System Overview' configuration page. On the left is a navigation menu with 'System Overview' selected. The main content area displays the following information:

- System name:** SENCITYlink A (max: 16 characters)
- Location:** Building A (max: 32 characters)
- System Status:** A traffic light icon with the green light illuminated. To the right, a legend indicates: red: System is not functional; yellow: System is working with intermittent detection and synchronization; green: System is working correctly.
- Serial number:** 84014310N000024
- Terminal Type:** A
- Firmware version:** 1.40
- Physical address (MAC):** 00:0D:86:00:04:84
- Hour meter:** 18278 h
- Time since last system reboot:** 000:00:13:11

At the bottom of the main content area are 'Apply' and 'Cancel' buttons.

5.1.2 Password screen

Default user name: admin
Default password: sl60

The screenshot shows the 'User Name/Password' configuration page. On the left is a navigation menu with 'User Name/Password' selected. The main content area displays the following information:

- User name:** admin (max: 16 characters)
- Current password:** (masked with 6 dots) (max: 16 characters)
- New password:** (masked with 6 dots) (max: 16 characters)
- Retype Password:** (masked with 6 dots) (max: 16 characters)

At the bottom of the main content area are 'Apply' and 'Cancel' buttons.

5.1.3 Firmware update screen

Current firmware can be downloaded from <http://www.hubersuhner.com/sl60> or requested via technical support. The downloaded file should be saved on the local computer and then uploaded to each terminal through the firmware update form on the web interface.

The screenshot shows the 'Firmware Update' section of the web interface. On the left is a navigation menu with 'System Configuration' and 'Link Configuration' sections. The main content area has a 'Firmware Update' section with a 'Firmware Version' of 1.40, an 'Upload firmware file' field with a 'Browse...' button, and a 'Start Upload' button. Below this is a 'Sysconfig Update' section with an 'Upload sysconfig file' field, a 'Browse...' button, and a 'Start Upload' button. At the bottom of the main content area are three buttons: 'Get sysconfig of this device', 'Reset System to factory settings' with a 'Reset' button, and 'Reboot System' with a 'Reboot' button.

5.1.4 Network configuration screen

The network configuration screen offers the option to change network settings if required. The IP address settings have no influence on data connectivity.

The screenshot shows the 'Network Configuration' section of the web interface. On the left is a navigation menu with 'System Configuration' and 'Link Configuration' sections. The main content area has a 'Network Configuration' section with a 'TCP/IP Configuration' sub-section. It offers two options: 'Get automatically (DHCP)' and 'Manual configuration'. The 'Manual configuration' option is selected, showing fields for 'IP address' (172, 21, 2, 25), 'Network mask' (255, 255, 255, 0), 'Default gateway' (172, 21, 2, 1), 'Domain name server 1', and 'Domain name server 2'. Below this is a 'Configuration of Ethernet Interface' section with 'AutoNegotiate' selected and 'Manual configuration' as an option. It includes settings for 'Duplex' (Half-duplex and Full-duplex), 'Speed' (10 mps and 100 mps), 'MDIX' (Auto MDI/MDIX and Manual configuration), and 'Force MDIX Mode' (Force MDIX Mode and No MDIX Mode). The 'Physical address (MAC)' is shown as 00:0D:86:00:04:04. At the bottom are 'Apply' and 'Cancel' buttons.

5.1.5 Radio alignment screen

The radio alignment screen shows specific details relating to the alignment of the two terminals.

The radio history file does log (once a minute) the following parameter values for the last 48 hours:

- Time since last reboot
Time format: <days>.<hours>:<minutes>
- Receive power at time XY ("minus" sign omitted)
- Device temperature in °C
- Lock detector: if unequal to 1, then the receivers are not locked

System Configuration
System Overview
User Name/Password
Firmware/Reboot
Link Configuration
Network Configuration
Radio Alignment
Network Statistics
SNMP Configuration
VLAN Configuration

Radio Alignment

Receiver Signal Strength: -78.4 dBm

System Status: red: System is not functional
yellow: System is working with intermittent detection and synchronization
green: System is working correctly

Receiver power range: High
Equipment temperature: 58 °F (14 °C)

Radio History File: [Get Log File](#)

Resynchronize System: The Local Terminal will be resynchronized to Far End Terminal

The resynchronization button can be used to restart the synchronization process with the far end terminal.

5.1.6 Network statistics screen

The network statistics screen shows standardized information relating to network traffic and errors. Traffic status information is continuously updated and specific network errors are listed.

System Configuration
System Overview
User Name/Password
Firmware/Reboot
Link Configuration
Network Configuration
Radio Alignment
Network Statistics
SNMP Configuration
VLAN Configuration

Network Statistics

The table displays the gathered packages over a period of 10 sec.

	Ethernet	Air
Pkts In (Rx)	135	125
Pkts Out (Tx)	126	134
Pkts Errors/Dropped (Rx)	0	0

5.1.7 SNMP configuration screen

The SL60-6004 terminal can be integrated into a network management system by using the implemented SNMP agent. This agent supports GET and TRAP functionality. No setting can be performed via SNMP.

System Configuration
System Overview
User Name/Password
Firmware/Reboot
Link Configuration
Network Configuration
Radio Alignment
Network Statistics
SNMP Configuration

SNMP Configuration

TRAP Destination: IP address or hostname
Community:
 Enable SNMP Traps

SNMP: [Get MIB for this device](#)

Note:

To use this feature you need an SNMP manager program such as HP OpenView or Castlerock's SNMPc.

The MIB file can be downloaded directly from the terminal.

5.1.8 VLAN configuration screen

The SL60-6004 terminal can be integrated into a VLAN. Configure the VLAN ID, IP address and subnet mask accordingly.

The screenshot shows a web-based configuration interface for VLAN settings. On the left is a navigation menu with the following items: System Configuration (bold), System Overview, User Name/Password, Firmware/Reboot, Link Configuration (bold), Network Configuration, Radio Alignment, Network Statistics, SNMP Configuration, and VLAN Configuration (highlighted). The main content area is titled 'VLAN Configuration' and contains the following fields: 'VLAN ID' with a text input field containing '0' and a label 'Integer: 2-4094'; 'VLAN IP' with four separate input fields, each containing '0'; and 'VLAN Netmask' with four separate input fields, each containing '0'. Below these fields is a checkbox labeled 'Enable VLAN' which is currently unchecked. At the bottom of the configuration area are two buttons: 'Apply' and 'Cancel'.

5.2 SNMP INTERFACE

Object	OID	OID type	Description
MIB-2 (iso.org.dod.internet.mgmt.mib-2.system.x / .1.3.6.1.2.1.1.x)			
sysDescr	.1.	DisplayString	Includes serial no.
sysUpTime	.3.	TimeTicks	Uptime of the network management
sysName	.5.	DisplayString	set in the web GUI
sysLocation	.6.	DisplayString	set in the web GUI
HUBERSUHNER-MIB sencity (.iso.org.dod.internet.private.enterprises.hubersuhnerOID.sencity.x / .1.3.6.1.4.1.25358.1.x)			
sencityLinkQuality	.1.	Integer	1: Green 2: Yellow 3: Red
sencityReceivePower	.10.	Integer	Receive signal level [dBm]
sencityTemperature	.11.	Integer	Temperature [°C]
sencityIfEthernetIn	.15.	Integer	Total frames received on the Ethernet interface
sencityIfEthernetOut	.16.	Integer	Total frames sent on the Ethernet interface
sencityIfEthernetInError	.17.	Integer	Total frames dropped due to errors received on the Ethernet interface
sencityIfAirIn	.18.	Integer	Total frames received on the Air interface
sencityIfAirOut	.19.	Integer	Total frames sent on the Air interface
sencityIfAirInError	.20.	Integer	Total frames dropped due to errors received on the Air interface
sencityFirmwareversion	.21.	String	Installed firmware version

Object	OID	OID type	Description
HUBERSUHNER-MIB sencitytraps (.iso.org.dod.internet.private.enterprises.hubersuhnerOID.sencity.sencityTraps.x / .1.3.6.1.4.1.25358.1.22.x)			
sencityLinkQualityImprovedTrap	.1.	Integer	1: from red to green 2: from red to orange 3: from orange to green
sencityLinkQualityReducedTrap	.2.	Integer	1: from green to orange 2: from green to red 3: from orange to red
sencityTemperatureHighTrap	.3.	Integer	A trap indicating that the temperature within the terminal is over or below 70 degree Celcius
sencityTemperatureLowTrap	.4.	Integer	A trap indicating that the temperature within the unit is over or below -40 degree Celcius

5.3 RESET-CD

On the Reset-CD following functions are available

- Parameter reset
- Firmware upload
- Documents in PDF format

This CD can be indispensable if the terminal IP address is lost or the terminal is on DHCP modus in a network where no DHCP server is available. In those cases, even though the data transmission is not influenced, the terminal monitoring functions are not accessible.

By using the parameter reset functionality it is possible to reset the terminal to the factory default IP addresses (see 5). Also, if username and/or password are lost, they can be reset using the parameter reset function (see section 5.3.1) of the CD.

This CD can be indispensable if during the firmware upload process it occurs a power breakdown or the Ethernet connection breaks. Then it will be needed to upload the firmware via Reset-CD to the terminal.

The Reset-CD is bootable, this means the computer is started by putting the Reset-CD into the optical drive (NOTE: the optical drive has to be defined on the computer firmware settings as a bootable device). With the CD a Linux operating system is loaded into the computer memory, so that the communication with the embedded linux of the terminal is enabled.

System requirements:

Intel compatible CPU (i486 or later), 32 MB RAM, CD-ROM drive as bootable device, Ethernet interface.

5.3.1 Parameter reset

The parameter reset function will reset all terminal parameters (e.g. IP address, username, password) to the factory defaults.

5.3.2 Firmware upload

With the firmware upload functionality a firmware can be uploaded to the terminal even the previous installed firmware is lost by power breakdown or Ethernet connectivity break during firmware upload process.

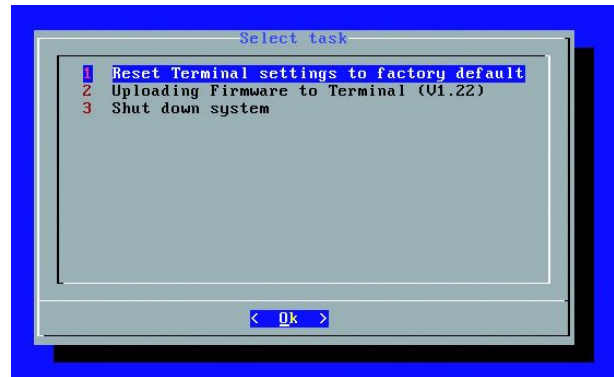

The CD contains useful documents (manual, installation video, etc.)

A TECHNICAL INFORMATION

A.1 TROUBLESHOOTING

This chapter provides solutions to problems that can occur during the installation and operation of the SL60-6004. It covers various aspects of installation and network setup.

Note:

Each of the following points must be checked at both ends of the link. Start by performing the entire procedure on one side (e.g. Terminal A). If this does not solve the problem, repeat all the steps at the opposite terminal.

A.1.1 Power and network connection

You must verify that the terminal is connected to the power. The PoE injector must be installed and plugged in. Go to the terminal, disconnect the RJ-45 connector and verify if there is power in the cable using a standard PoE tester.

Take the cable and plug it into a notebook or a network testing device and verify if there is a correct network connection.

If there is any problem, please replace the cable and validate the connection again. We provide special, preassembled outdoor CAT 5e cables to ensure easy installation.

A.1.2 Network configuration

Check that the IP address is in the same range and subnet as the SL60-6004.

Note:

The IP address of the SL60-6004 is 192.168.0.11 for Terminal A and 192.168.0.12 for Terminal B. All the computers on the network must have a unique IP address in the same range, e.g. 192.168.0.X. Any computers with identical IP addresses will not be visible on the network. They must all, therefore, have the same subnet mask e.g. 255.255.255.0.

Do a Ping test to make sure that the SL60-6004 is responding. Go to Start → Run → Type “Command” → Type “ping 192.168.0.X”. A successful Ping test will generate four replies.

As soon as the network configuration is correct you can access the GUI (Graphical User Interface) and check the settings according to section 4.9.

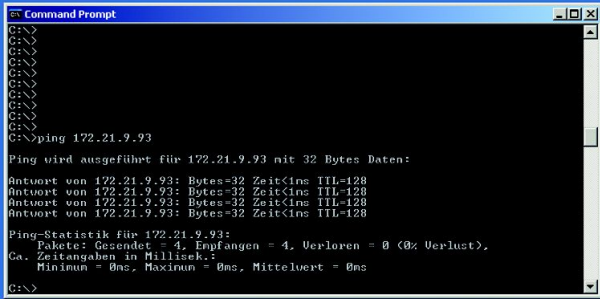

```
C:\>
C:\>
C:\>
C:\>
C:\>
C:\>
C:\>
C:\>ping 172.21.9.93
Ping wird ausgeführt für 172.21.9.93 mit 32 Bytes Daten:
Antwort von 172.21.9.93: Bytes=32 Zeit<ms TTL=128
Antwort von 172.21.9.93: Bytes=32 Zeit<ms TTL=128
Antwort von 172.21.9.93: Bytes=32 Zeit<ms TTL=128
Antwort von 172.21.9.93: Bytes=32 Zeit<ms TTL=128
Ping-Statistik für 172.21.9.93:
    Pakete: Gesendet = 4, Empfangen = 4, Verloren = 0 (0% Verlust),
    Ca. Zeitangaben in Millisek.:
        Minimum = 0ms, Maximum = 0ms, Mittelwert = 0ms
C:\>
```

A.1.3 Duplex mismatch

If you encounter bad network performance, you probably have a duplex mismatch.

To ensure that the SL60-6004 terminal and the connected network component (e.g. switch) do not have a duplex mismatch you must first check your statistics.

If you find many input errors, you are on the full-duplex side; if you see many late collisions, you are on the half-duplex side.

To solve the duplex mismatch, you must manually configure both network components to the same values.

A.1.4 Miss-alignment

See the configuration interface as described in section 5.1.4. On the Radio alignment screen (see section 5.1.5) you see the signal strength in dBm (e.g. -30 dBm). If the value is below -95 dBm the receiver is not in the correct position to track the signal. You therefore need to re-align the terminal to its opposite terminal

(please follow the instructions in section 4.5.1).

A.2 SPECIFICATIONS

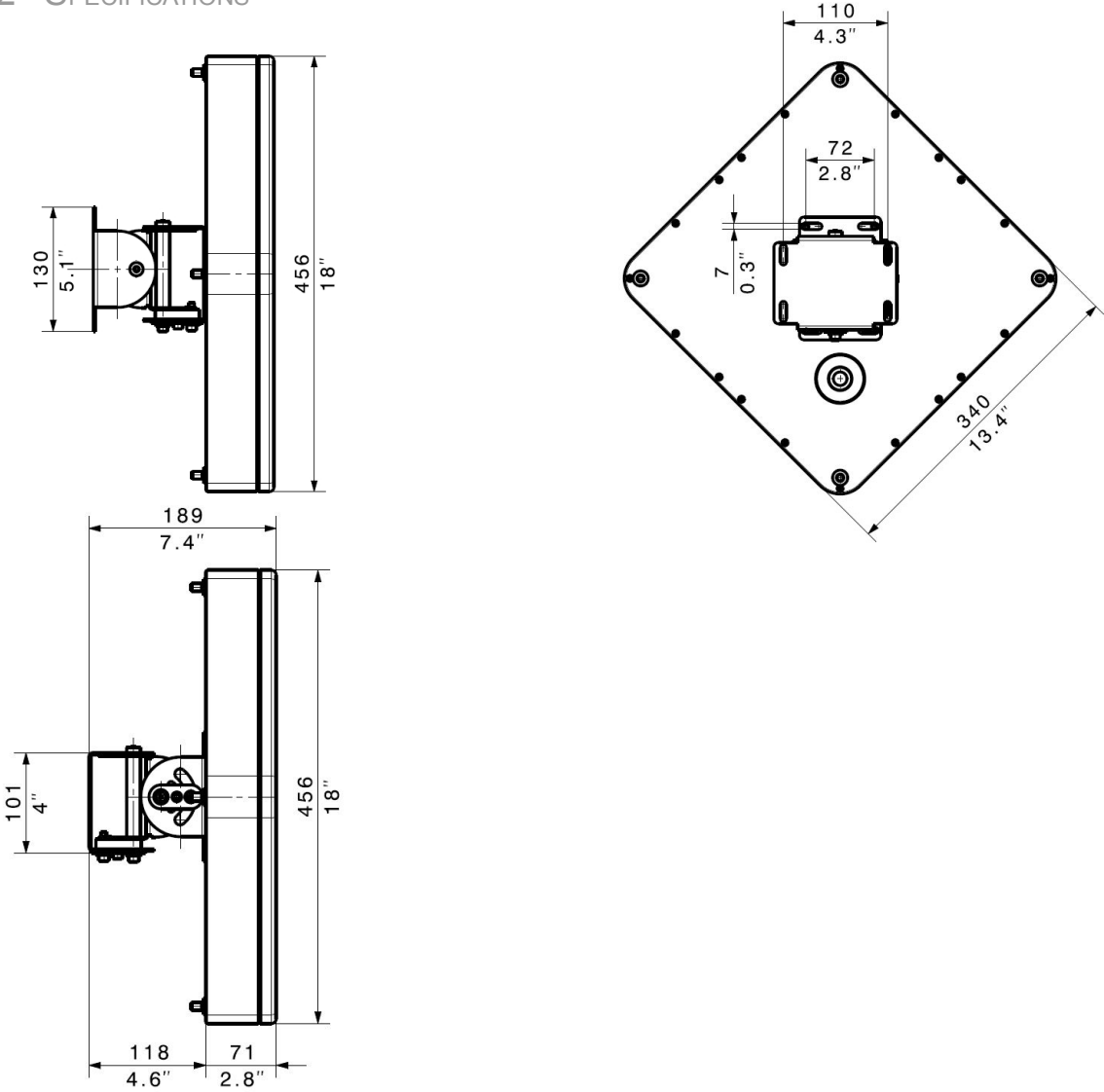

General system information

- Transmission Capacity: 100 Mbps Full Duplex
- Interface: 100 Base-TX
- Latency: < 50 μ s + distance
latency (1 μ s / 300 m)
- Range*: up to 800 m (2600 ft)
- Availability*: up to 99.999%
- Warranty: 1 year

Connection

- Cable Length: max. 100 m (300 ft)
- Signal Wires: CAT 5e
- Connector: RJ-45 (male; including outdoor Ethernet seal kit)

Mechanical data

- Dimension: 340 x 340 x 71 mm
(13.4" x 13.4" x 2.8")
- Weight: 7500 g (16.5 lb) terminal

System administration

- Management: SNMP
Web browser-based configuration

Power supply

- Standards: Compliant to Power over Ethernet according to IEEE 802.3af
- Voltage: \pm 48 V DC
- Power Consumption: 11 W

Environmental data

- Working Temperature **: - 45 °C ... + 55 °C
(- 49 °F ... + 131 °F)
- Storage Temperature: - 30 °C ... + 55 °C
(- 22 °F ... + 131 °F)
- Wind Load: operating 160 km/h (100 mph)
survival 200 km/h (125 mph)

Regulatory

- Regulatory Compliance:
 - FCC Part 15
 - Industry Canada RSS210
 - R&TTE Directive 1999/5/EC

Ordering information

- SL60-6004: Item # 84071429
 - composed of:
 - 2 Terminals
 - 2 Alignment brackets
 - 1 Manual
 - 2 Mounting sets
 - 1 Reset-CD
 - 2 Ice bridges

* The range depends on the climate zone and the requested availability

** Only if the terminal is powered up

A.2.1 Ethernet cable colour code

Note:
By cutting of the connector the warranty will expire.

Pin	Name	RJ45 Plug
		8 7 6 5 4 3 2 1 
1	TX+	Black
2	TX-	Green
3	RX+	Red
4	Power+	Blue
5	Power+	White
6	RX-	Orange
7	Power-	Yellow
8	Power-	Brown

Twisted pairs:

- Black / Green
- Yellow / Brown
- Red / Orange
- Blue / White

A.3 RECEIVER LEVEL / RAIN / LINK DISTANCE

The following diagram shows the approximate receiver levels at different rain rates and distances. This diagram is valid for A and B terminals delivered with firmware version 1.40.

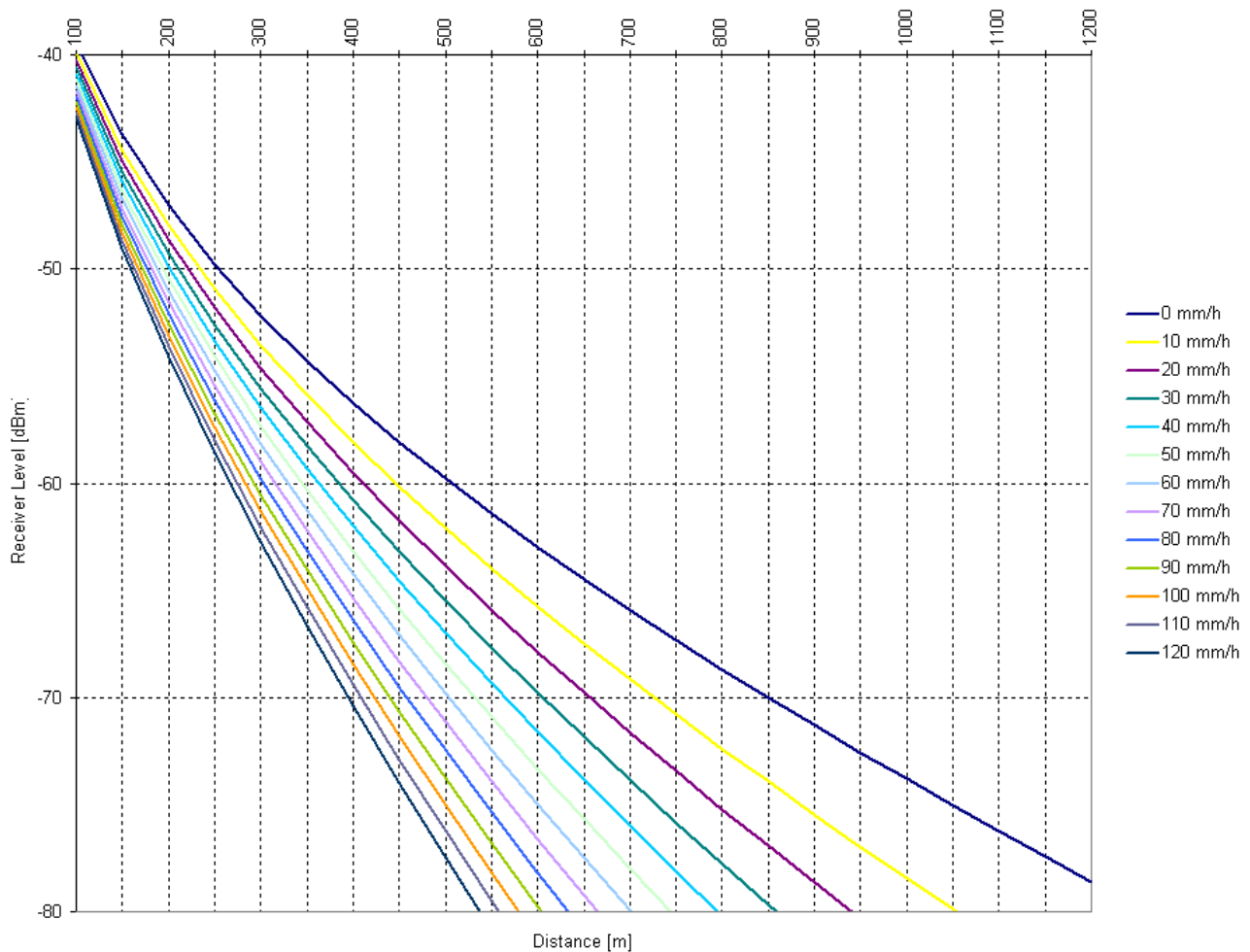

A.4 AVAILABILITY / RAIN ZONE / LINK DISTANCE

A.4.1 Map of America

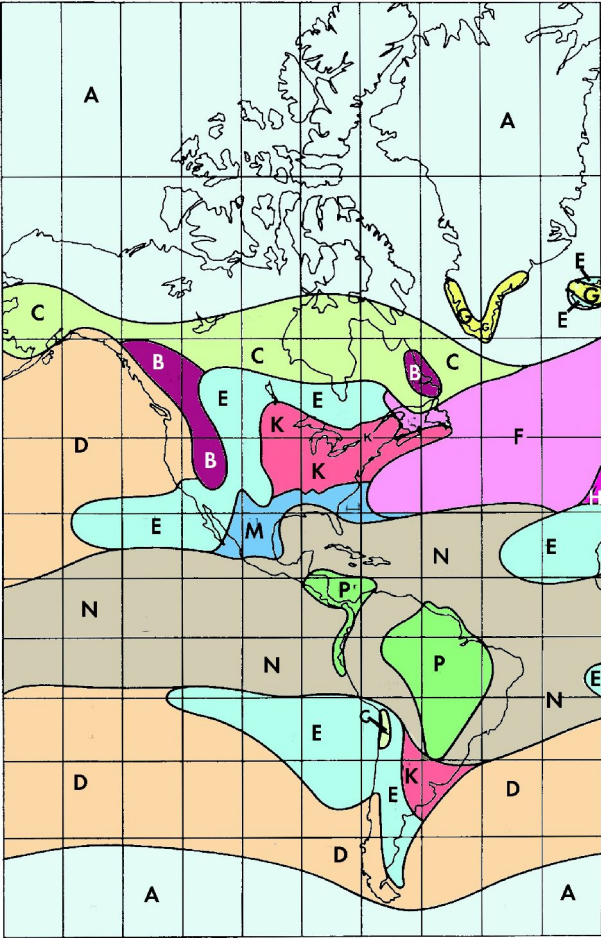

The link distance is directly related to the weather conditions. The table below refers to a link working at a distance of up to 1200 m (dry weather).

Availability	Rain zone *														
	Link distance (m)														
	A	B	C	D	E	F	G	H	J	K	L	M	N	P	Q
99%	1195	1180	1174	1137	1177	1147	1117	1139	1029	1152	1139	1097	1078	975	857
99.9%	1139	1117	1078	1029	1061	1029	975	1001	891	975	941	874	780	642	619
99.99%	1029	975	941	901	874	827	813	799	780	741	661	649	556	463	513
99.999%	874	799	741	741	625	601	642	587	680	544	456	504	419	355	430

* Rain zone according to ITU-R Recommendation PN.837-1

99.9% availability equates to 526 minutes per year of outage due to heavy rains.

99.99% availability equates to 53 minutes per year of outage due to heavy rains.

99.999% availability equates to 5 minutes per year of outage due to heavy rains.

A.4.2 Map of Asia and Middle East

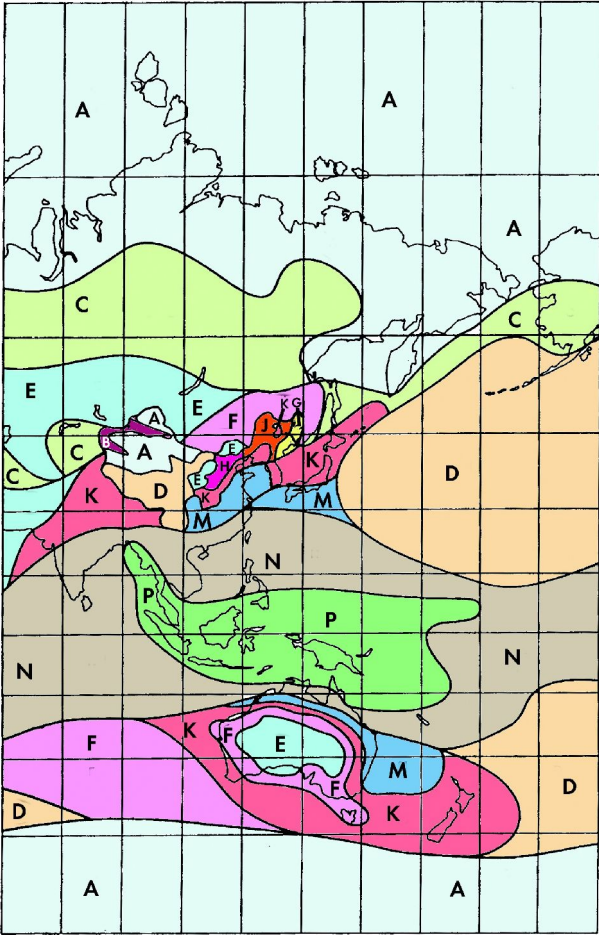

The link distance is directly related to the weather conditions. The table below refers to a link working at a distance of up to 1200 m (dry weather).

Availability	Rain zone *														
	Link distance (m)														
	A	B	C	D	E	F	G	H	J	K	L	M	N	P	Q
99%	1195	1180	1174	1137	1177	1147	1117	1139	1029	1152	1139	1097	1078	975	857
99.9%	1139	1117	1078	1029	1061	1029	975	1001	891	975	941	874	780	642	619
99.99%	1029	975	941	901	874	827	813	799	780	741	661	649	556	463	513
99.999%	874	799	741	741	625	601	642	587	680	544	456	504	419	355	430

* Rain zone according to ITU-R Recommendation PN.837-1

99.9% availability equates to 526 minutes per year of outage due to heavy rains.

99.99% availability equates to 53 minutes per year of outage due to heavy rains.

99.999% availability equates to 5 minutes per year of outage due to heavy rains.

A.4.3 Map of Europe

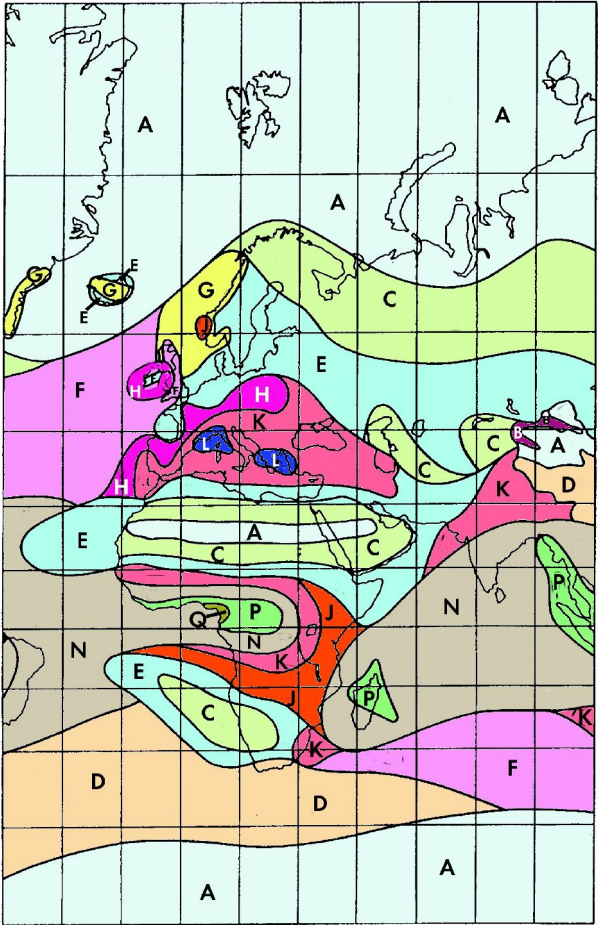

The link distance is directly related to the weather conditions. The table below refers to a link working at a distance of up to 1200 m (dry weather).

Availability	Rain zone *														
	Link distance (m)														
	A	B	C	D	E	F	G	H	J	K	L	M	N	P	Q
99%	1195	1180	1174	1137	1177	1147	1117	1139	1029	1152	1139	1097	1078	975	857
99.9%	1139	1117	1078	1029	1061	1029	975	1001	891	975	941	874	780	642	619
99.99%	1029	975	941	901	874	827	813	799	780	741	661	649	556	463	513
99.999%	874	799	741	741	625	601	642	587	680	544	456	504	419	355	430

* Rain zone according to ITU-R Recommendation PN.837-1

99.9% availability equates to 526 minutes per year of outage due to heavy rains.

99.99% availability equates to 53 minutes per year of outage due to heavy rains.

99.999% availability equates to 5 minutes per year of outage due to heavy rains.

A.5 ACCESSORIES ORDER INFORMATION

Item number	Description
23033695	Data Line Protector (indoor) To use only in combination with an outdoor protector.
84014284	Data Line Protector (outdoor)
84021330	PoE 802.3af Tester



Item number	Description
84021333	PoE 802.3af Power Injector
84079242	SENCITY®Link Alignment Bracket
84015652	Mast Bracket
84069796	Visual Alignment Tool

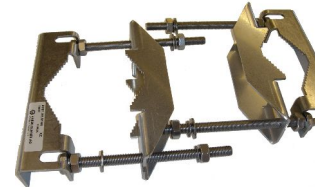
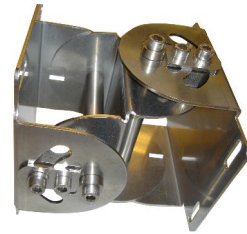

Item number	Description
84022128	Ice Bridge
84031068 84028025 84028026 84028029	Outdoor Ethernet Cable 2 m Outdoor Ethernet Cable 10 m Outdoor Ethernet Cable 30 m Outdoor Ethernet Cable 90 m
84034955	Encryption Box HiSec 220



Item number	Description
84044851	Sealed Ethernet connection RJ45



B COUNTRY SPECIFIC INFORMATION

B.1.1 Switzerland, Germany

B.1.1.1 English

Indication about the correct use of the system

The devices of this system establish a wireless point to point data connection.

Indication about possible application limitations

Operation on NIB / NPB (Non interference basis / non protection basis): The equipment is not permitted to cause harmful interference to other radio services. The equipment has to be switched off immediately in the case of interference with other services.

Indication about the network interfaces to which the system can be connected

The devices are intended to be connected to IEEE standard 802.3af (Power over Ethernet) compliant devices. SL60-6004 has to be supplied by a limited power source according to EN 60950-1:2006.

B.1.1.2 Deutsch

Hinweis auf bestimmungsgemässe Verwendung der Anlage

Die Geräte dieser Anlage stellen eine drahtlose Punkt-zu-Punkt Datenverbindung her.

Hinweis auf mögliche Verwendungseinschränkungen

Interferenzen und Schutzvorkehrungen im Betrieb: Die Ausrüstung ist nicht gestattet, andere Funkdienste nachteilig zu stören. Das Gerät muss im Falle von Interferenzen mit anderen Diensten sofort ausgeschaltet werden.

Hinweis auf die Netzchnittstellen, an welche die Anlage angeschlossen werden kann

Die Geräte sind für den Anschluss an dem IEEE-Standard 802.3af (Power over Ethernet) konforme Geräte bestimmt. SL60-6004 muss durch eine Stromquelle begrenzter Leistung gemäss EN 60950-1:2006

gespiesen werden.

B.1.1.3 Français

Indication concernant l'utilisation correcte de l'installation

L'équipement de cette installation établis une liaison de données point à point sans fil.

Indication concernant de possible restrictions de l'utilisation

Interférence et protection pendant le fonctionnement: Le matériel n'est pas permis de causer des interférences nuisibles à d'autres services radio. Le matériel doit être mis hors service immédiatement dans le cas d'interférence avec d'autres services.

Indication concernant les interfaces du réseau auxquelles l'installation peut être raccordé

L'équipement est conçu pour le raccordement aux appareils conformes au standard IEEE 802.3af (Power over Ethernet). SL60-6004 doit être alimenté par une source de courant fini selon EN 60950-1:2006.

B.1.1.4 Italiano

Indicazione concernente l'utilizzo corretto e l'installazione

Le componenti installate di questo sistema creano un ponte radio punto-punto.

Indicazione concernente le possibili restrizioni dell'utilizzo

Interferenze e protezione durante l'utilizzo: il sistema non deve causare alcuna interferenza nociva ad altri servizi radio. Questo sistema deve essere spento immediatamente nel caso di interferenza con altri servizi.

Indicazione concernente le interfacce alle quali il sistema può essere connesso

Il sistema è concepito per essere connesso all'interfaccia conforme allo standard IEEE 802.3af (Power over Ethernet). SL60-6004 deve essere alimentato da un'alimentazione conforme alle specifica EN 60950-1:2006.

C CONTACTS

C.1.1 Technical assistance

Please visit <http://www.hubersuhner.com/sl60>

C.1.2 Service center / RMA

USA / Canada toll free phone number:

1-800-348-9008

D GLOSSARY

DHCP	Dynamic Host Configuration Protocol DHCP enables both manual and automatic IP address allocation in a network.	SNMP	Simple Network Management Protocol
DNS	Domain Name System enables the translation from IP address to domain name	TCP	Transmission Control Protocol
CE	The CE marking is a conformity mark on products placed on market in the European Economic Area.	WAN	Wide Area Network
FCC	Federal Communication Commission (USA)	WLAN	Wireless Local Area Network. This typically unlicensed non line of site application operates in the frequency range 2 - 6 GHz according to IEEE 802.11x.
IP	Internet Protocol		
LAN	Local Area Networks		
LOS	Line of Sight – uninterrupted, visual, point-to-point contact.		
MAC address	Media Access Control physical, unique address of network component		
OSHA	Occupational Safty and Health Administration		
PoE	Power over Ethernet according to IEEE 802.3af that provides for a standardized power model.		
QPSK	Quadrature Phase Shift Keying		

E NOTES

HUBER+SUHNER (Australia) Pty. Ltd.
Unit 6, 4 Skyline Place
Frenchs Forest
Sydney NSW 2086 (Australia)
Telefon: +61 2 8977 1200
Fax: +61 2 9972 7549
E-Mail: webenq.au@hubersuhner.com

HUBER+SUHNER GmbH
Mehlbeerenstrasse 6
Postfach 1263
82019 Taufkirchen (Germany)
Telefon: +49 89 6 12 01-0
Fax: +49 89 6 12 01162
E-Mail: info.de@hubersuhner.com

HUBER+SUHNER Electronics Pvt. Ltd.
359, Udyog Vihar, Phase II
Gurgaon 122016
Haryana (India)
Telefon: +91 124 5102701/02/03
Fax: +91 124 5102704
E-Mail: info.in@hubersuhner.com

HUBER+SUHNER América Latina Ltda.
Avenida Rui Barbosa, 3613
Alto da Ponte
Sao José dos Campos -
SP 12213 300 (Brazil)
Telefon: +55 12 3946 9 500
Fax: +55 12 3946 9 527
E-Mail: info.br@hubersuhner.com

HUBER+SUHNER A/S
Kirke Værløsevej 14
3500 Værløse (Denmark)
Telefon: +45 48 100 500
Fax: +45 48 100 555
E-Mail: info@hubersuhner.dk

HUBER+SUHNER AB
Knarrarnäsgatan 7
Box 1247
SE 164 28 Kista, Stockholm (Sweden)
Telefon: +46 8 447 5200
Fax: +46 8 447 5201
E-Mail: info.se@hubersuhner.com

HUBER+SUHNER (Canada) Ltd.
2650 Queensview Drive
Suite 206
Ottawa ON K2B 8H6 (Canada)
Telefon: +1 613 721 4111
Fax: +1 613 721 8480
E-Mail: info@hubersuhner.ca

HUBER + SUHNER France
21 E, rue Jacques CARTIER
78960 Voisins le Bretonneux (France)
Telefon: +33 1 61 37 25 55
Fax: +33 1 30 64 73 68
E-Mail: info.fr@hubersuhner.com

HUBER+SUHNER (Singapore) Pte. Ltd.
Number 8, Tuas Avenue 5
Singapore 639334 (Singapore)
Telefon: +65 6861 8186
Fax: +65 6861 3316
E-Mail: webenq.sg@hubersuhner.com

HUBER+SUHNER AG
Degersheimerstrasse 14
Postfach
9100 Herisau (Switzerland)
Telefon: +41 71 353 4111
Fax: +41 71 353 4444
E-Mail: info@hubersuhner.com
Website: www.hubersuhner.com

HUBER+SUHNER (Hong Kong) Ltd.
Suite 1601, 16/F
Chung Nam Building
1 Lockhart Road
Wanchai, Hong Kong (China)
Telefon: +852 2866 6600
Fax: +852 2866 6313
E-Mail: webenq.hk@hubersuhner.com

HUBER+SUHNER (UK) Ltd.
Telford Road
Bicester Oxfordshire OX26 4LA (UK)
Telefon: +44 1869 364 100/101
Fax: +44 1869 249 046
E-Mail: info.uk@hubersuhner.com

HUBER+SUHNER Inc.
19 Thompson Drive
Essex VT 05452 (USA)
Telefon: +1 802 878 0555
Fax: +1 802 878 9880
E-Mail: info.us@hubersuhner.com

**HUBER+SUHNER is certified according
to ISO 9001 and ISO 14001.**

WAIVER

It is exclusively in written agreements that we provide our customers with warrants and representations as to the technical specifications and/or the fitness for any particular purpose. The facts and figures contained herein are carefully compiled to the best of our knowledge, but they are intended for general informational purposes only.

HUBER+SUHNER AG
RF Technology
CH-9100 Herisau/Switzerland
Tel. +41 (0)71 353 41 11
Fax +41 (0)71 353 45 90
www.hubersuhner.com