



WIFI Module

Fn-Link

3131A-S

User's Manual

Revision History

Version	Date	Description	Draft	Approved
1.0	2017-06-01	First release	Colin Ming	William Tan
1.1	2017-06-22	Modified input voltage range	Colin Ming	William Tan
1.1	2017-06-22	Added 32.768K clock input requesting	Colin Ming	William Tan
1.2	2017-07-14	Modified Pin13、39、40 function	Colin Ming	William Tan
1.3	2017-08-04	Modified SDIO specification description	Colin Ming	William Tan

CONTENTS

1. Introduction	1
2. Features	2
3. General Specification	2
3.1 General Specification.....	2
4. WiFi RF Specification	3
4.1 2.4GHz RF Specification.....	3
5. Power Consumption	5
6. Pin Assignments	6
6.1 Pin Outline	6
6.2 Pin Definition	6
7. Dimensions	8
7.1 Physical Dimensions	8
7.2 Module Physical Dimensions.....	9
7.3 Layout Recommendation.....	10
8. Host Interface Timing Diagram	11
8.1 SDIO Pin Description.....	11
8.2 SDIO Default Mode Timing Diagram	11
8.3 SDIO High Speed Mode Timing Diagram	12
8.4 SDIO Bus Timing Specifications in SDR Modes	13
9.Reference Design	14
10.Recommended Reflow Profile	15
11. Packing Information	16

1. Introduction

3131A-S is a small size and low profile of WiFi module, board size is 12mm*12mm with module thickness of 1.7mm. It can be easily manufactured on SMT process and highly suitable for tablet PC, ultra book, mobile device and consumer products. It provides SDIO interface for WiFi. The WiFi throughput can go up to 150Mbps in theory by using 1x1 802.11b/g/n SISO technology.

3131A-S uses highly integrated WiFi single chip based on advanced COMS process. 3131A-S integrates whole WiFi function blocks into a chip, such as SDIO/MPU, MAC, BB, AFE, RFE, PA, EEPROM and LDO/SWR, except fewer passive components remained on PCB.

2. Features

- Operate at ISM frequency bands (2.4GHz)
- SDIO interface for WiFi
- Low power dissipation
- High transmitting power
- High receiving sensitivity
- IEEE standards support: IEEE 802.11b, IEEE 802.11g, IEEE 802.11n.
- Enterprise level security which can apply WPA/WPA2 certification for WiFi.
- WiFi 1 transmitter and 1 receiver allow data rates supporting up to 150 Mbps downstream and 150 Mbps upstream PHY rates

3. General Specification

3.1 General Specification

Model Name	3131A-S
Product Description	Support WiFi functionality
Dimension	L x W x H: 12 x 12 x1.8 (typical) mm
WiFi Interface	Support SDIO
Operating temperature	-30°C to 70°C
Storage temperature	-40°C to 125°C

3.1.2 Recommended Operating Rating

	Min.	Typ.	Max.	Unit
Operating Temperature	-30	25	70	deg.C
VCC33	3.3	3.6	4.8	V
VDDIO	-	1.8V	-	V

Note: Suggested power input range in 3.6V-4.5V.

4. WiFi RF Specification

4.1 2.4GHz RF Specification

Feature	Description
Operating Frequency	2.412~2.462GHz
Standards	WiFi: IEEE 802.11b, IEEE 802.11g, IEEE 802.11n, IEEE 802.11d, IEEE 802.11e, IEEE 802.11h, IEEE 802.11i
Modulation	WiFi: 802.11b: DSSS(1M,2Mbps), CCK(11, 5.5Mbps), 802.11 g/n: OFDM
PHY Data rates	WiFi: 802.11b: 11,5.5,2,1 Mbps 802.11g: 54,48,36,24,18,12,9,6 Mbps 802.11n: up to 150Mbps
Transmit Output Power	WiFi: 802.11b \cong 18.5 dBm 802.11g \cong 16.5 dBm 802.11n \cong 15.5 dBm (MCS 7_HT20) \cong 14.5 dBm (MCS 7_HT40)
EVM	802.11b /1Mbps : EVM \cong -10dB 802.11b /11Mbps : EVM \cong -10dB 802.11g /6Mbps : EVM \cong -5dB 802.11g /54Mbps : EVM \cong -25dB 802.11n /6.5Mbps : EVM \cong -5dB 802.11n /65Mbps : EVM \cong -28dB 802.11n /13.5Mbps : EVM \cong -5dB 802.11n /135Mbps : EVM \cong -28dB
Receiver Sensitivity (WiFi)	802.11b@10% PER 1Mbps \cong -98dBm 2Mbps \cong -94dBm 5.5Mbps \cong -93dBm 11Mbps \cong -90dBm Max input level \geq -8
	802.11g@10% PER 6Mbps \cong -94dBm 9Mbps \cong -92dBm

	<p>12Mbps \cong -91dBm 18Mbps \cong -89dBm 24Mbps \cong -86dBm 36Mbps \cong -82dBm 48Mbps \cong -78dBm 54Mbps \cong -77dBm Max input level \geq -20</p>																
	<p>802.11n@10% PER</p> <table> <tr> <td>HT20_MCS 0 \cong -93dBm</td> <td>HT40_MCS 0 \cong -90</td> </tr> <tr> <td>HT20_MCS 1 \cong -90dBm</td> <td>HT40_MCS 1 \cong -87</td> </tr> <tr> <td>HT20_MCS 2 \cong -88dBm</td> <td>HT40_MCS 2 \cong -85</td> </tr> <tr> <td>HT20_MCS 3 \cong -85dBm</td> <td>HT40_MCS 3 \cong -82</td> </tr> <tr> <td>HT20_MCS 4 \cong -82dBm</td> <td>HT40_MCS 4 \cong -79</td> </tr> <tr> <td>HT20_MCS 5 \cong -78dBm</td> <td>HT40_MCS 5 \cong -75</td> </tr> <tr> <td>HT20_MCS 6 \cong -76dBm</td> <td>HT40_MCS 6 \cong -73</td> </tr> <tr> <td>HT20_MCS 7 \cong -75dBm</td> <td>HT40_MCS 7 \cong -71</td> </tr> </table> <p>Max input level \geq -20</p>	HT20_MCS 0 \cong -93dBm	HT40_MCS 0 \cong -90	HT20_MCS 1 \cong -90dBm	HT40_MCS 1 \cong -87	HT20_MCS 2 \cong -88dBm	HT40_MCS 2 \cong -85	HT20_MCS 3 \cong -85dBm	HT40_MCS 3 \cong -82	HT20_MCS 4 \cong -82dBm	HT40_MCS 4 \cong -79	HT20_MCS 5 \cong -78dBm	HT40_MCS 5 \cong -75	HT20_MCS 6 \cong -76dBm	HT40_MCS 6 \cong -73	HT20_MCS 7 \cong -75dBm	HT40_MCS 7 \cong -71
HT20_MCS 0 \cong -93dBm	HT40_MCS 0 \cong -90																
HT20_MCS 1 \cong -90dBm	HT40_MCS 1 \cong -87																
HT20_MCS 2 \cong -88dBm	HT40_MCS 2 \cong -85																
HT20_MCS 3 \cong -85dBm	HT40_MCS 3 \cong -82																
HT20_MCS 4 \cong -82dBm	HT40_MCS 4 \cong -79																
HT20_MCS 5 \cong -78dBm	HT40_MCS 5 \cong -75																
HT20_MCS 6 \cong -76dBm	HT40_MCS 6 \cong -73																
HT20_MCS 7 \cong -75dBm	HT40_MCS 7 \cong -71																
Operating Channel	<p>WiFi 2.4GHz:</p> <p>11: (Ch. 1-11) – United States 13: (Ch. 1-13) – Europe</p>																
Media Access Control	WiFi: CSMA/CA with ACK																
Antenna	See page 18																
Network Architecture	<p>Ad-hoc mode (Peer-to-Peer) Infrastructure mode Software AP WiFi Direct</p>																
Security	WPA, WPA-PSK, WPA2, WPA2-PSK, WEP 64bit & 128bit, IEEE 802.11x, IEEE 802.11i																
OS Supported	Android /Linux																
Host Interface	SDIO2.0																
Operating Voltage	3.3-4.8V Vdc, 1.8V I/O supply voltage																
Dimension	Typical 12*12*1.8 mm																

5. Power Consumption

Power Consumption (Typical by using SWR)	TX Mode: (Throughput mode) 230mA (MCS7/BW40/16dBm) RX Mode: (Throughput mode) 66mA (MCS7/BW40/-60dBm) Associated Idle power saving with DTIM=3 0.38mA Deep Sleep: 0.04mA
---	---

6. Pin Assignments

6.1 Pin Outline

< TOP VIEW >

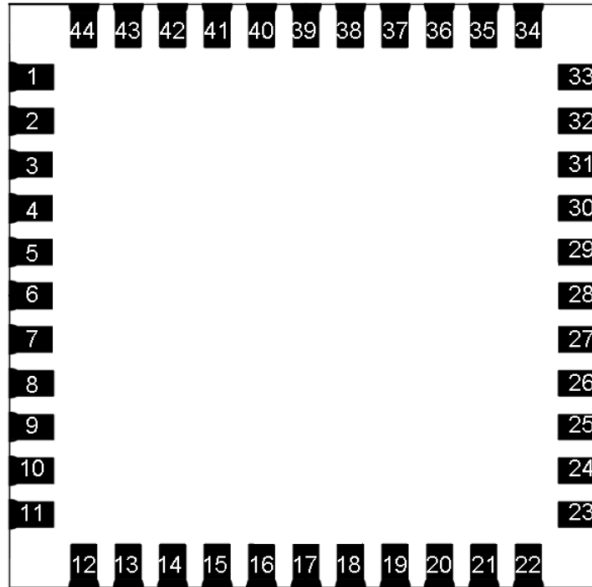

6.2 Pin Definition

NO	Name	Type	Description
1	GND	—	Ground connections
2	WL_ANT	I/O	RF I/O port
3	GND	—	Ground connections
4	NC	—	Floating (Don't connected to ground)
5	NC	—	Floating (Don't connected to ground)
6	Host wake device	I	Host Wake up WiFi, rising edge trigger
7	GPIO3	I/O	Floating (Don't connected to ground)
8	NC	—	Floating (Don't connected to ground)
9	VCC	P	Main power voltage source input 3.3V-4.8V
10	NC	—	Floating (Don't connected to ground)
11	NC	—	Floating (Don't connected to ground)
12	PMU_POWRON	I	Enable pin for WLAN device ON: pull high ; OFF: pull low
13	GPIO1	I/O	SDIO data interrupt
14	SDIO_DATA_2	I/O	SDIO data line 2
15	SDIO_DATA_3	I/O	SDIO data line 3
16	SDIO_DATA_CMD	I/O	SDIO command line

17	SDIO_DATA_CLK	I	SDIO clock line
18	SDIO_DATA_0	I/O	SDIO data line 0
19	SDIO_DATA_1	I/O	SDIO data line 1
20	GND	—	Ground connections
21	NC	—	Floating (Don't connected to ground)
22	VDDIO	P	I/O Voltage supply input 1.8V
23	NC	—	Floating (Don't connected to ground)
24	RTC_CLK	I	Exteral 32.768Khz clock input for Power saving
25	NC	—	Floating (Don't connected to ground)
26	NC	—	Floating (Don't connected to ground)
27	NC	—	Floating (Don't connected to ground)
28	NC	—	Floating (Don't connected to ground)
29	NC	—	Floating (Don't connected to ground)
30	NC	—	Floating (Don't connected to ground)
31	GND	—	Ground connections
32	NC	—	Floating (Don't connected to ground)
33	GND	—	Ground connections
34	GPIO2	I/O	Floating (Don't connected to ground)
35	NC	—	Floating (Don't connected to ground)
36	GND	—	Ground connections
37	NC	—	Floating (Don't connected to ground)
38	NC	—	Floating (Don't connected to ground)
39	WL_RST	I	WiFi reset pin, internal pull high. Low: reset enable, High: reset disable
40	Dev_Wake_Host	O	WiFi wake up host, rising edge trigger for host, high level trigger for MCU.
41	NC	—	Floating (Don't connected to ground)
42	NC	—	Floating (Don't connected to ground)
43	NC	—	Floating (Don't connected to ground)
44	NC	—	Floating (Don't connected to ground)

7. Dimensions

7.1 Physical Dimensions

(Unit: mm)

< TOP VIEW >

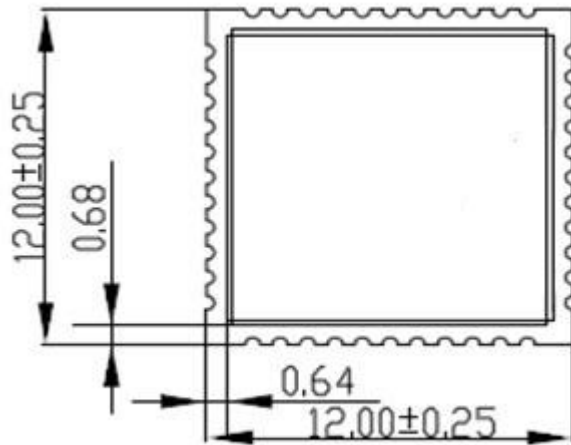

< Side View >



7.2 Module Physical Dimensions

(Unit: mm)

< TOP VIEW >

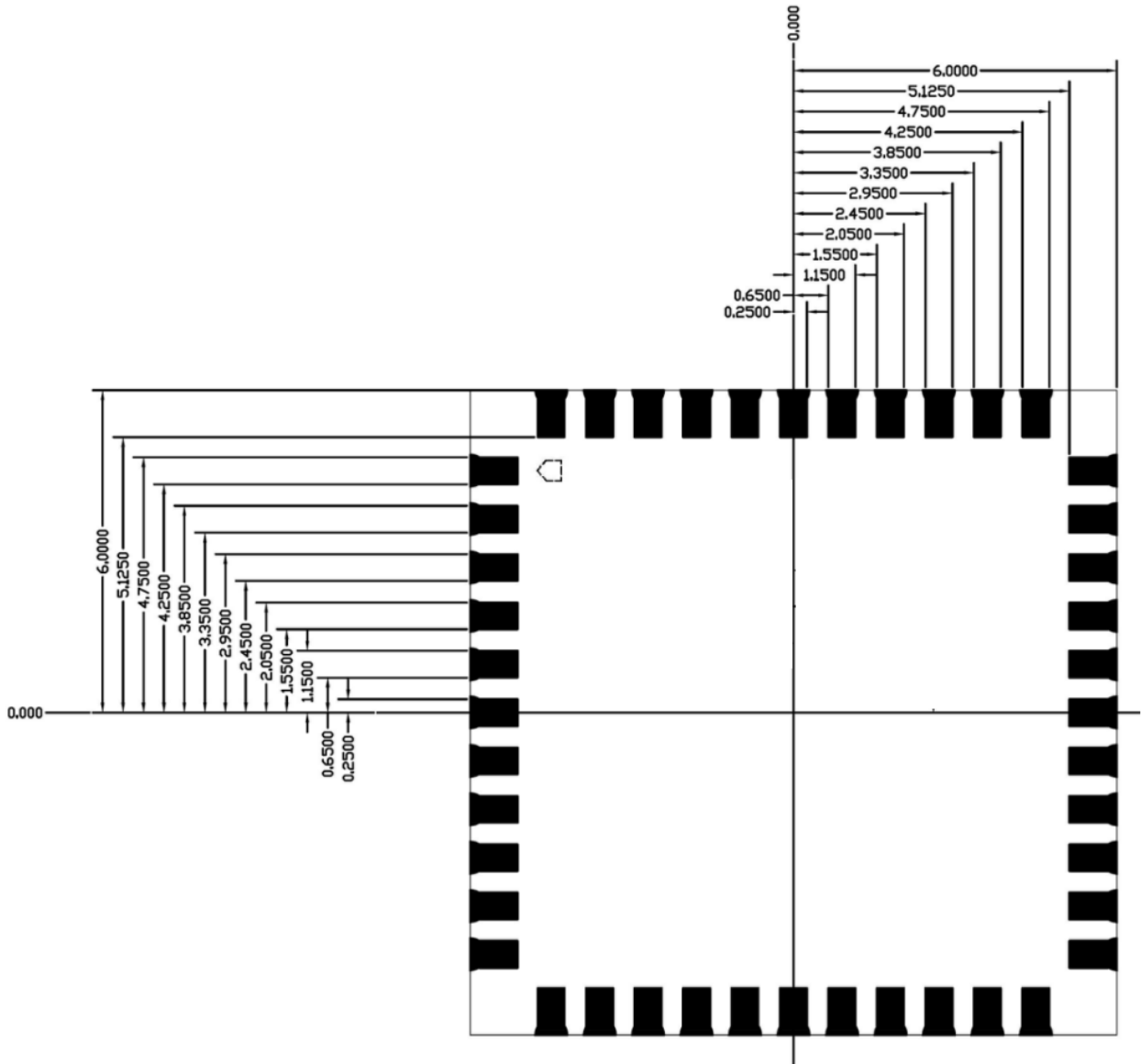

7.3 Layout Recommendation

(Unit: mm)

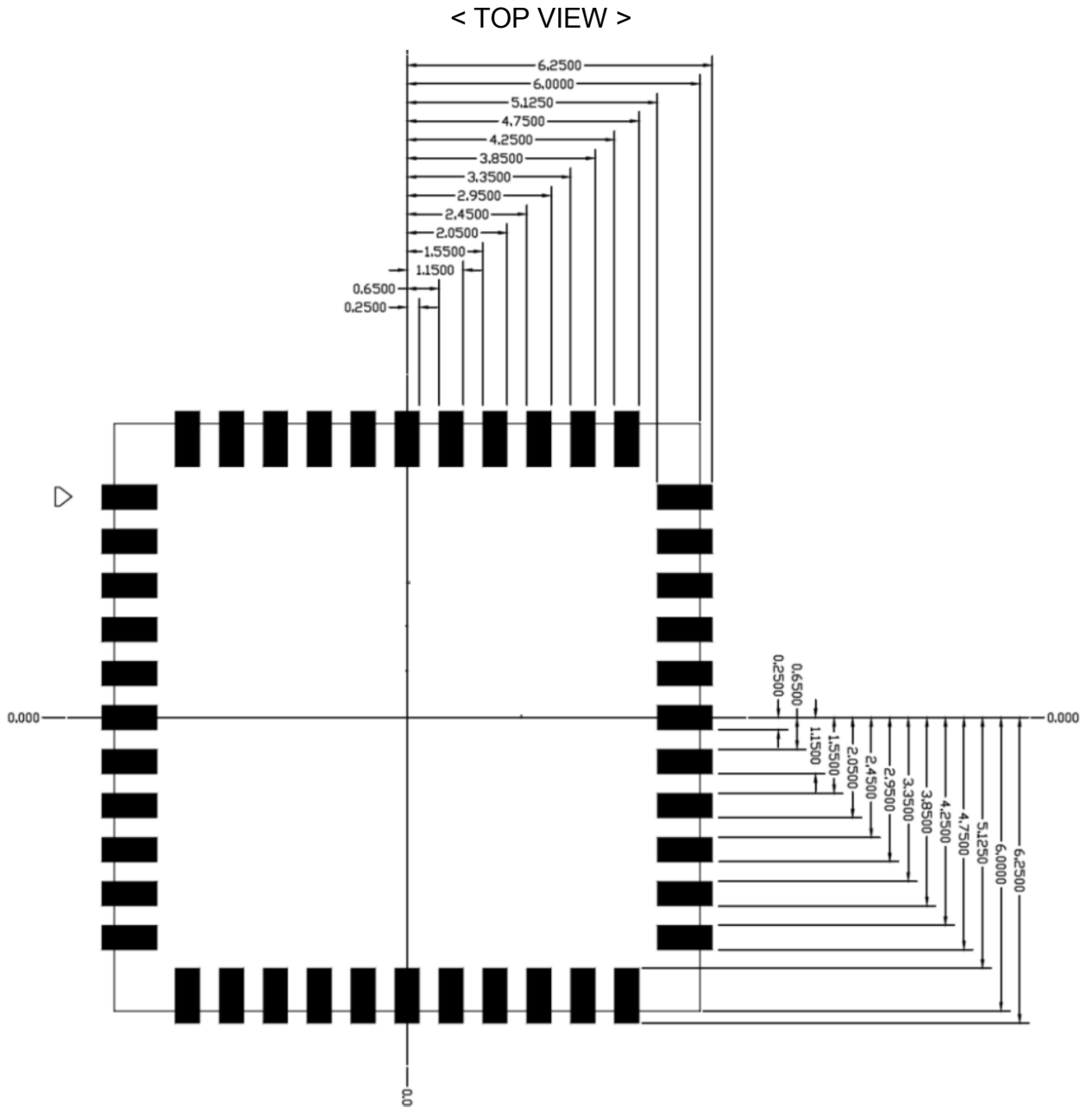

8. Host Interface Timing Diagram

8.1 SDIO Pin Description

The module supports SDR12(25MHz) and SDR25(50MHz, dual rates) in addition to the 1.8V default speed(25MHz) and high speed (50 MHz). It has the ability to stop the SDIO clock and map the interrupt signal into a GPIO pin. This ‘out-of-band’ interrupt signal notifies the host when the WLAN device wants to turn on the SDIO interface. The ability to force the control of the gated clocks from within the WLAN chip is also provided.

SDIO Pin Description

SD 4-Bit Mode	
DATA0	Data Line 0
DATA1	Data Line 1 or Interrupt
DATA2	Data Line 2 or Read Wait
DATA3	Data Line 3
CLK	Clock
CMD	Command Line

8.2 SDIO Default Mode Timing Diagram

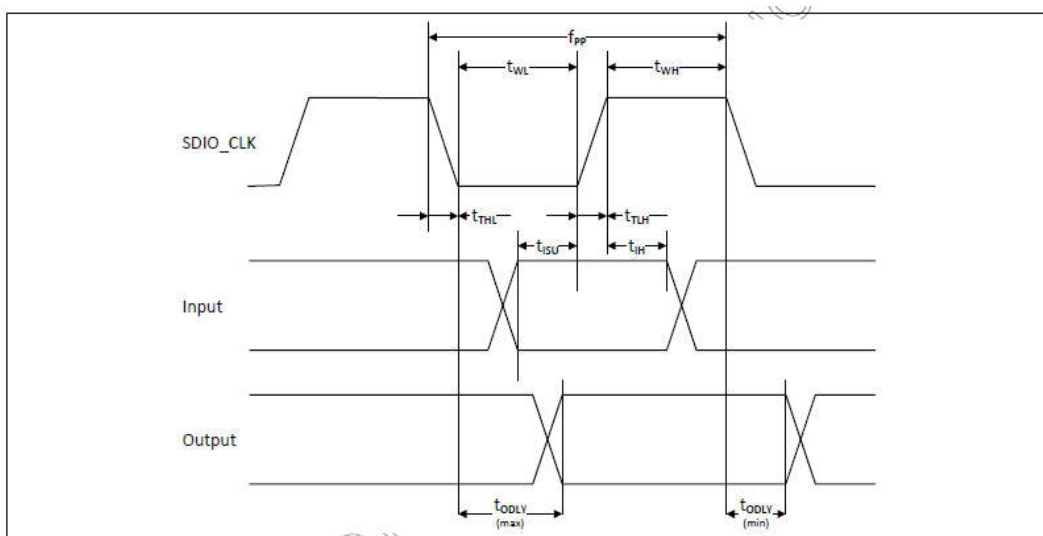

Parameter	Symbol	Minimum	Typical	Maximum	Unit
SDIO CLK (All values are referred to minimum VIH and maximum VIL^b)					
Frequency – Data Transfer mode	fPP	0	–	25	MHz
Frequency – Identification mode	fOD	0	–	400	kHz
Clock low time	tWL	10	–	–	ns
Clock high time	tWH	10	–	–	ns
Clock rise time	tTLH	–	–	10	ns
Clock low time	tTHL	–	–	10	ns
Inputs: CMD, DAT (referenced to CLK)					
Input setup time	tISU	5	–	–	ns
Input hold time	tIH	5	–	–	ns
Outputs: CMD, DAT (referenced to CLK)					
Output delay time – Data Transfer mode	tODLY	0	–	14	ns
Output delay time – Identification mode	tODLY	0	–	50	ns

- a. Timing is based on $CL \leq 40\text{pF}$ load on CMD and Data.
 b. $\min(V_{ih}) = 0.7 \times V_{DDIO}$ and $\max(V_{il}) = 0.2 \times V_{DDIO}$.

8.3 SDIO High Speed Mode Timing Diagram

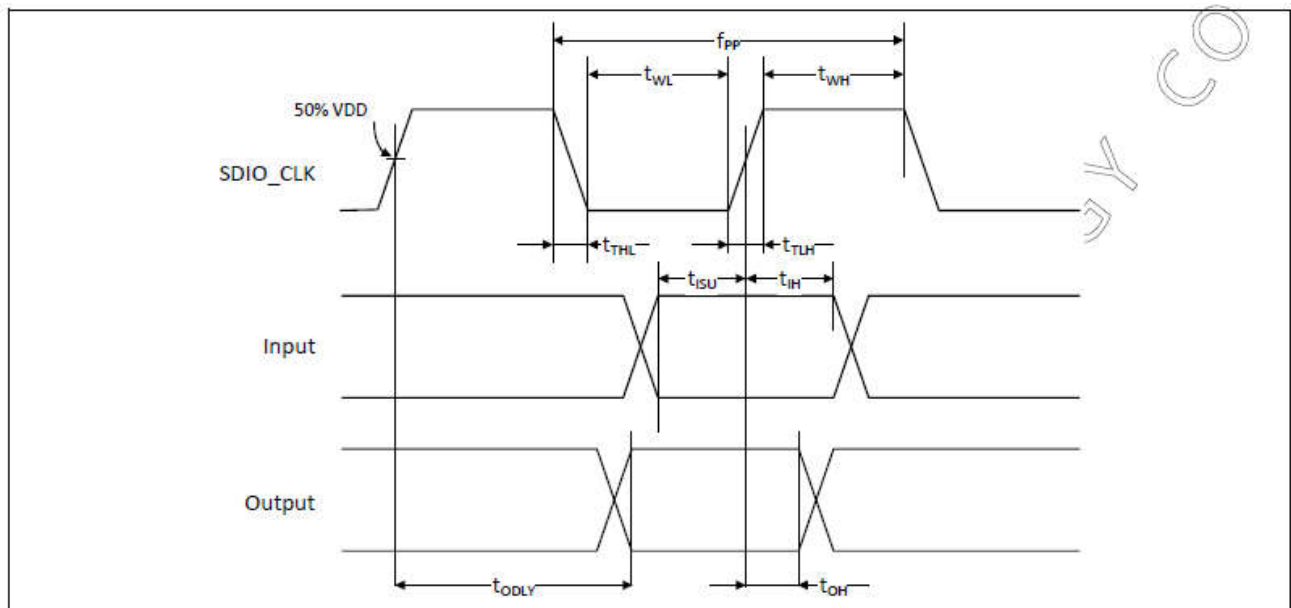

Parameter	Symbol	Minimum	Typical	Maximum	Unit
SDIO CLK (all values are referred to minimum VIH and maximum VIL^b)					
Frequency – Data Transfer Mode	fPP	0	–	50	MHz
Frequency – Identification Mode	fOD	0	–	400	kHz
Clock low time	tWL	7	–	–	ns
Clock high time	tWH	7	–	–	ns
Clock rise time	tTLH	–	–	3	ns
Clock low time	tTHL	–	–	3	ns
Inputs: CMD, DAT (referenced to CLK)					
Input setup Time	tISU	6	–	–	ns
Input hold Time	tIH	2	–	–	ns
Outputs: CMD, DAT (referenced to CLK)					
Output delay time – Data Transfer Mode	tODLY	–	–	14	ns
Output hold time	tOH	2.5	–	–	ns
Total system capacitance (each line)	CL	–	–	40	pF

- a. Timing is based on $CL \leq 40$ pF load on CMD and Data.
- b. $\min(V_{ih}) = 0.7 \times V_{DDIO}$ and $\max(V_{il}) = 0.2 \times V_{DDIO}$.

8.4 SDIO Bus Timing Specifications in SDR Modes

Clock timing(SDR Modes)

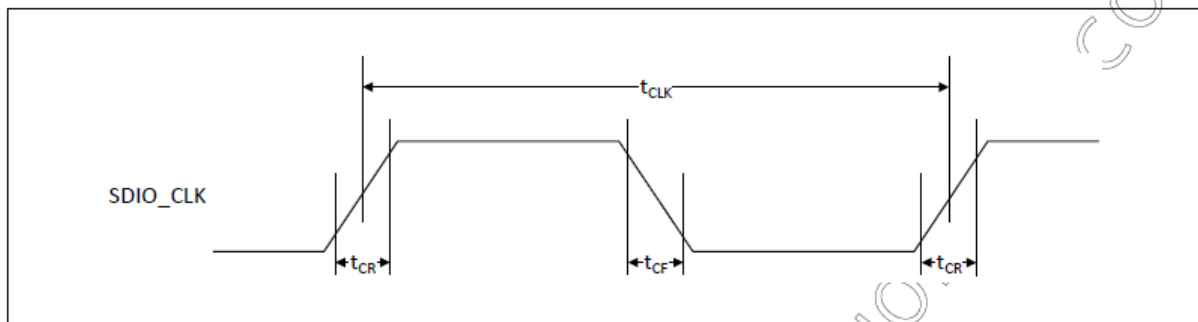

9. Reference Design

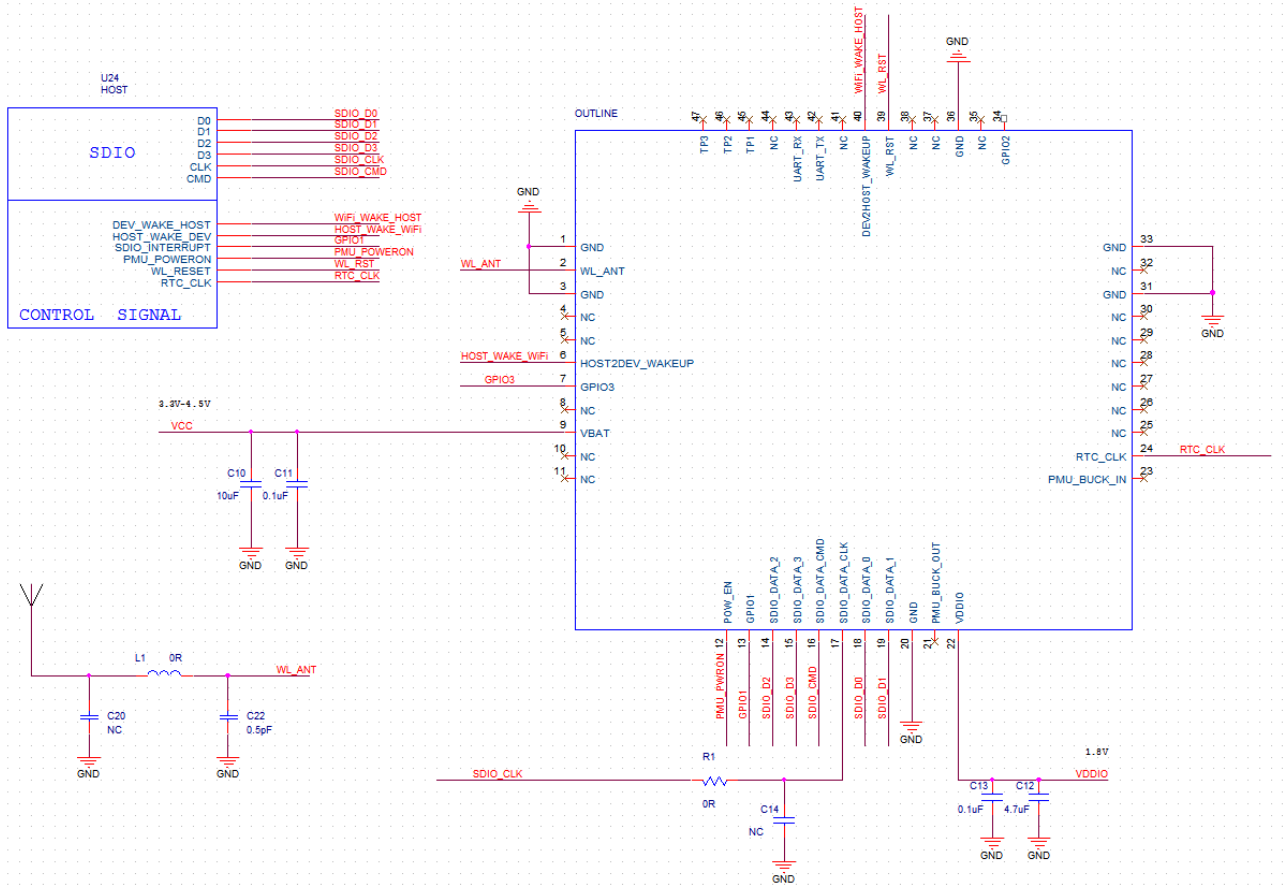

10. Recommended Reflow Profile

Referred to IPC/JEDEC standard.

Peak Temperature : <250°C

Number of Times : ≤2 times

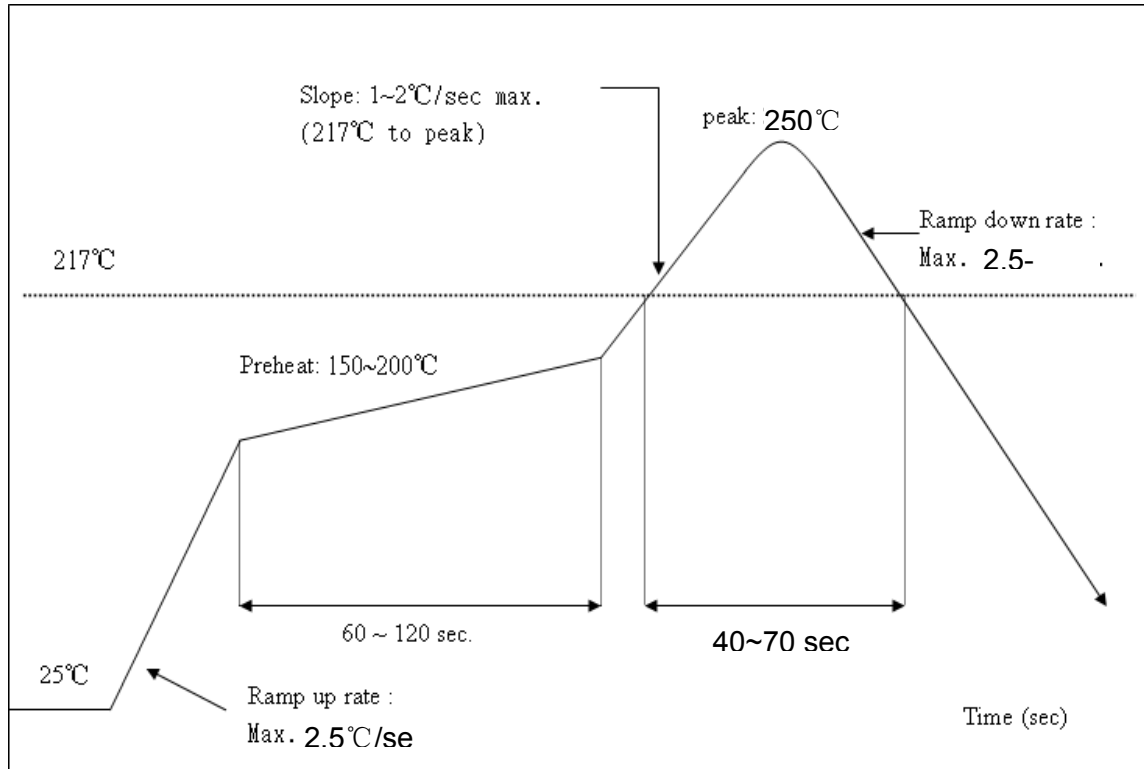

11. Packing Information

Tape and Reel Package



Using self-adhesive tape

Size of black tape: 24mm*32.6m the cover tape: 21.3mm*32.6m

Color of plastic disc: blue

A roll of 2000pcs



NY bag size:460mm*385mm



size : 350*350*35mm



The packing case size:350*210*370mm

This module has been designed to operate with a PIFA antenna having a maximum gain of 2dBi. Only this type of antenna may be used, the manufacturer recommended antenna as

below:

Ant. (Chain)	Brand	Model name	Antenna Type	Connector	Gain (dBi)
1	XK	XKFPC-2D4-5D8-1 50	PIFA	I-PEX	0.0
2	XK	XK-QX2400-PCB-1 40	PIFA	I-PEX	2.0

- Note: 1. This module has only one antenna port
2. Antenna 1 and antenna 2 are used for different customers.

FCC Statement:

This device complies with part 15 of the FCC Rules.

Operation is subject to the following two conditions:

(1) This device may not cause harmful interference, and (2) this device must accept any interference received, including interference that may cause undesired operation.

Note: This equipment has been tested and found to comply with the limits for a Class B digital device, pursuant to Part 15 of the FCC Rules. These limits are designed to provide reasonable protection against harmful interference in a residential installation. This equipment generates, uses and can radiate radio frequency energy and, if not installed and used in accordance with the instructions, may cause harmful interference to radio communications.

However, there is no guarantee that interference will not occur in a particular installation. If this equipment does cause harmful interference to radio or television reception, which can be determined by turning the equipment off and on, the user is encouraged to try to correct the interference by one or more of the following measures:

- Reorient or relocate the receiving antenna.
- Increase the separation between the equipment and receiver.
- Connect the equipment into an outlet on a circuit different from that to which the receiver is connected.
- Consult the dealer or an experienced radio/TV technician for help.

FCC Radiation Exposure Statement

This equipment complied with FCC radiation exposure limits set forth for an uncontrolled environment. This equipment should be installed and operated with minimum distance 20cm between the radiator & your body.

Warning: Changes or modifications to this unit not expressly approved by the part responsible for compliance could void the user's authority to operate the equipment.

LABEL OF THE END PRODUCT:

The final end product must be labeled in a visible area with the following "Contains TX FCC ID:" 2AATL-3131A-S", and the FCC part 15.19 statement has to be available on the label: This device complies with Part 15 of the FCC Rules. Operation is subject to the following two conditions: (1) this device may not cause harmful interference, and (2) this device must accept any interference received, including interference that may cause undesired operation.

If the end product is so small or for such use that it is not practicable to place the statement specified, the statement shall be placed in a prominent location in the instruction manual or pamphlet supplied to the user or, alternatively, shall be placed on the container in which the device is marketed.

Note: The module is limited to OEM installation ONLY; The OEM integrator is responsible for ensuring that the end-user has no manual instructions to remove or install module.

This product is mounted inside of the end product only by professional installers OEM. They use this module with changing the power and control signal setting by software of end product within the scope of this application. End user can not change this setting.

The equipment complies with RF exposure limits. This module is limited to installation in mobile or fixed applications. The antenna used for this transmitter must not be co-located or operating in conjunction with any other antenna or transmitter.

The module must in the end-product be installed in such manner that the authorized antennas can be used, any change of the antenna will void the certification.