

THANK YOU!

We are grateful for your purchase of HYT product. We believe this easy-to-use radio will provide you with clear and reliable communications **at peak efficiency**. This HYT portable two-way radio is a precision device. Treat it with care, and you will enjoy years of reliable operation.

MODELS COVERED IN THIS MANUAL

TC-600 UHF Two-way Radio

Contents

User Safety, Training, and General Information

Compliance with RF Energy Exposure Standards

FCC Compliance

Precautions

Product Inspection

Battery Information

Accessory Installation

Radio Overview

Features and Operation

Basic Operations

Time-Out-Timer (TOT)

Battery Save

Low Battery Alert

Monitor

Programmable Function Key

High/Low Power

Compatible Channel Bandwidth

2-Tone Encode & Decode

DTMF ANI

CTCSS/DCS Signalling

Signalling AND/OR Logic

Channel Scan

Busy Channel Lockout

Troubleshooting Guide

Care and Cleaning

Optional Accessories

Frequency Chart

■ User Safety, Training, and General Information

READ THIS IMPORTANT INFORMATION ON SAFE AND EFFICIENT OPERATION BEFORE USING YOUR HYT PORTABLE TWO-WAY RADIO.

■ Compliance with RF Energy Exposure Standards

Your HYT two-way radio is designed and tested to comply with a number of national and international standards and guidelines (listed below) regarding human exposure to radio frequency electromagnetic energy. This radio complies with the IEEE (FCC) and ICNIRP exposure limits for occupational/controlled RF exposure environment at duty cycles of up to 50% talk-50% listen and should be used for occupational use only. In terms of measuring RF energy for compliance with the FCC exposure guidelines, your radio radiates measurable RF energy only while it is transmitting (during talking), not when it is receiving (listening) or in standby mode.

Note: The approved batteries supplied with this radio are rated for a 5-5-90 duty cycle (5% talk-5% listen-90% standby), even though this radio complies with the FCC occupational RF exposure limits at duty cycles of up to 50% talk.

Your HYT two-way radio complies with the following of RF energy exposure standards and guidelines:

- United States Federal Communications Commission, Code of Federal Regulations; 47CFR part 2 sub-part J
- American National Standards Institute (ANSI)/Institute of Electrical and Electronic Engineers (IEEE) C95. 1-1992
- Institute of Electrical and Electronic Engineers (IEEE) C95. 1-1999 Edition
- International Commission on Non-Ionizing Radiation Protection (ICNIRP) 1998

Operational Instructions and Training Guidelines

To ensure optimal performance and compliance with the occupational/controlled environment RF energy exposure limits in the above standards and guidelines, users should transmit no more than 50% of the time and always adhere to the following procedures:

Transmit and Receive

To transmit (talk), push the Push-To-Talk (PTT) button; to receive, release the PTT button.

Hand-held radio operation

Hold the radio in a vertical position with the microphone one to two inches (2.5 to 5 cm) away from the lips.

Body-worn operation

- Always place the radio in an HYT approved clip, holder, holster, case, or body harness for this product. Use of non-HYT-approved accessories may exceed FCC RF exposure guidelines.

Antennas & Batteries

- Use only HYT approved, supplied antenna or HYT approved replacement antenna. Unauthorized antennas, modifications, or attachments could damage the radio and may violate FCC regulations.
- Use only HYT approved, supplied batteries or HYT approved replacement batteries. Use of non- HYT -approved batteries may exceed FCC RF exposure guidelines.

Approved Accessories

For a list of HYT approved accessories, see the accessories page of this user manual or visit the following website which lists approved accessories: <http://www.HYT.com.cn>

■ FCC Compliance

This equipment has been tested and found to comply with the limits for a Class B digital device, pursuant to part 15 of the FCC Rules. These limits are designed to provide reasonable protection against harmful interference in a residential installation. This equipment generates, uses and can radiate radio frequency energy and, if not installed and used in accordance with the instructions, may cause harmful interference to radio communications. However, there is no guarantee that interference will not occur in a particular installation. If this equipment does cause harmful interference to radio or television reception, which can be determined by turning the equipment off and on, the user is encouraged to try to correct the interference by one or more of the following measures:

- Reorient or relocate the receiving antenna.
- Increase the separation between the equipment and receiver.
- Connect the equipment into an outlet on a circuit different from that to which the receiver is connected.
- Consult the dealer or an experienced radio/TV technician for help.

FCC Requirements

Your radio must be properly licensed Federal Communications Commission prior to use. Your HYT Wireless dealer can assist you in meeting these requirements. Your dealer will program each radio with your authorized frequencies, signaling codes, etc., and will be there to meet your communications needs as your system expands.

■ Precautions

- Only qualified technicians are allowed to maintain this product.
- Do not use the radio or charge a battery in explosive areas such as coal gas, dust, steam, etc.
- Switch OFF the radio while refueling or parking at gas station.
- Do not modify or adjust this radio without permission.
- Do not expose the radio to direct sunlight over a long time, nor place it close to heating source.
- Do not place the radio in excessively dusty, humid areas, nor on unstable surfaces.

Safety: It is important that the operator is aware of and understands hazards common to the operation of any radio.

Product Inspection

Please carefully unpack the radio. Before use, it is recommended that you inspect the product as follows.

First check the shipping carton for any signs of damage. Confirm the supplied product against the packing slip to assure accuracy. If any items are missing or have been damaged during shipment, please contact your dealer immediately.

Supplied Accessories

Item	Qty. (pcs)
Antenna *	1
Charger	1
Switch Power	1
Li-ion Battery Pack	1
Belt Clip	1
Strap	1
Owner's Manual	1

***Note:**

Frequency is marked on the color circle of the antenna. Red circle indicates UHF. If frequency is not marked on the color circle, please refer to the label on the main unit for details.

Battery Information

Battery Charging Information

The battery is not charged at the factory. Batteries must be fully charged before initial use or if they have not been used for some period of time.

The battery capacity will be optimum only after being charged / discharged for two or three times. When the battery power is low, it either needs to be charged or replaced with a new one.

Notices:

Do not **short** the battery terminals or dispose of the battery by fire.

Turn off the radio when charging the attached battery.

Remove the radio and the battery from the charger when charging cycle is over. **Do not recharge the battery** if it is already fully charged. Overcharging will shorten the battery life.

Store the battery in a place about room temperature (25°C). Charging the battery in temperatures less than 10°C may cause electrolyte leakage and damage the battery.

Charging the battery in temperatures greater than 35°C will affect the battery capacity.

Battery Charging

Insert the battery or the radio with battery into the charger, and make sure **that the battery connectors are in contact with the charging terminals**. The LED glows red during charging and green when battery is fully charged.

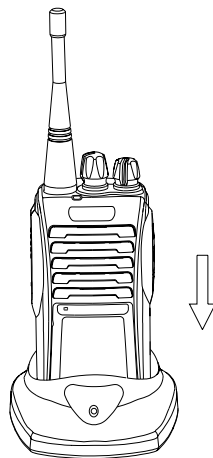

Accessory Installation

Attaching the Battery

1. Turn off the radio.
2. Insert the tabs at the bottom of the battery into the slots at the bottom of the radio chassis.
3. Press the top of the battery towards the radio until a “click” is heard. (See Figure 1)

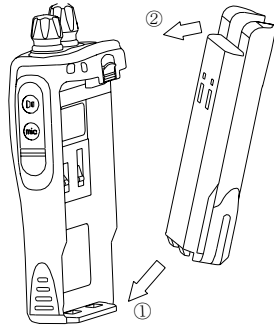

(Fig. 1)

Removing the Battery

1. Turn off the radio.
 2. Push the battery latch on the back panel towards the top of the radio.
 3. Pull the top of the battery away from the radio chassis, and lift the battery from the radio.
- (See Figure 2)

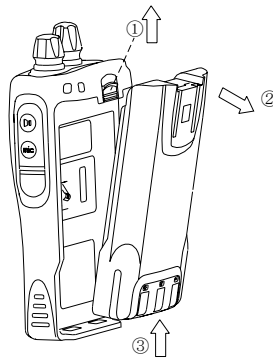

(Fig. 2)

Attaching the Antenna

1. Align the threaded end of the antenna with the radio’s antenna connector.

2. Turn the antenna clockwise to tighten. (See Figure 3)

Removing the Antenna

1. Turn the antenna **counterclockwise** until you can remove it. (See Figure 3)

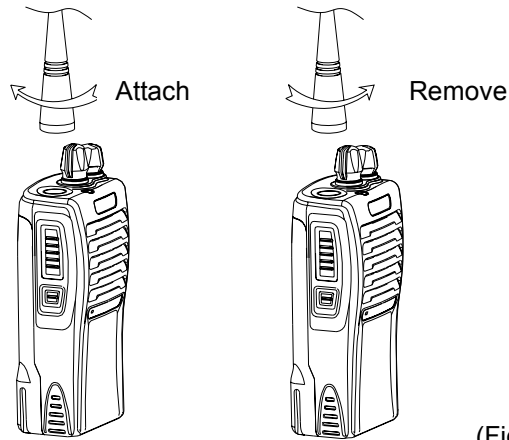

(Fig. 3)

Attaching the Belt Clip

1. Align the grooves of the belt clip with those of the battery.

2. Press the belt clip downwards until the belt clip tab locks. (See Figure 4)

Note: attach the belt clip before installing the battery.

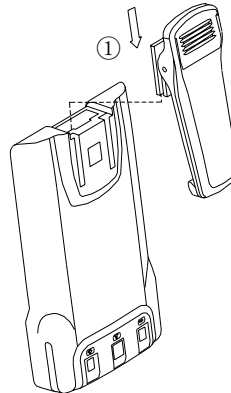

(Fig. 4)

Removing the Belt Clip

1. Press the belt clip tab upwards until it releases.

2. Slide the belt clip upwards to remove it. (See Figure 5)

Note: remove the battery pack prior to removing the belt clip.

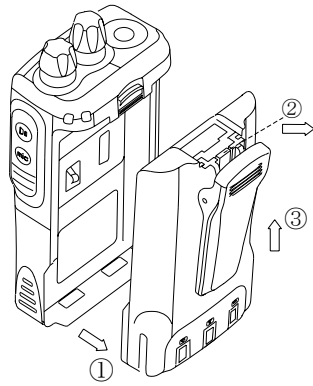

(Fig. 5)

Attaching External Earphone (Optional)

1. Remove the cover of earphone jack.
2. Rotate the cover until earphone jack comes into view.
3. Insert the earphone plug into the jack.

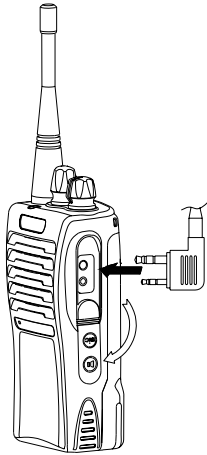

Radio Overview

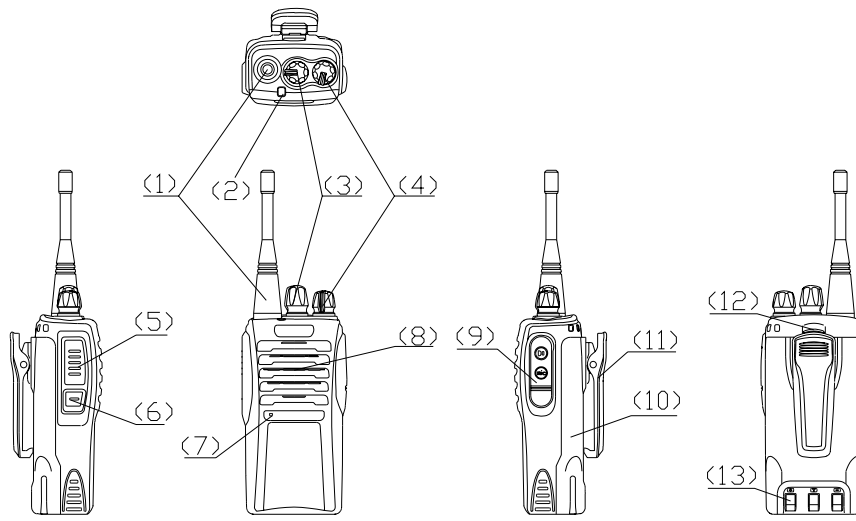

(1) Antenna

Used to transmit/receive signals.

(2) LED Indicator

The radio LED glows red during transmission and green during reception; The LED flashes red when battery voltage is low.

(3) Channel Selector Knob

(4) Power/Volume Control Knob

Rotate the knob clockwise until a “click” is heard to turn the radio on, fully counter clockwise until a “click” is heard to turn the radio off. When the radio is on, turn the knob to adjust volume.

(5) PTT Key

Hold down the [PTT] key to transmit, release it to receive.

(6) Function Key

The key can be programmed to access the radio features with the preset type of key pressing through the programming software.

(7) Microphone

Used to input sounds.

(8) Speaker

Used to output sounds.

(9) External Jack (for external earphone or radio programming)

Rotate the jack cover and insert accessory plug or insert programming cable into the jack to program the radio via programming software.

(10) Battery

(11) Belt Clip

Used to clip radio on your belt.

(12) Battery Latch

Used to fasten and remove the battery.

(13) Charging Connector

Insert the battery into the charger; connect the charging connectors with those on the charger to begin charging.

Features and Operation

Basic Operations

1. Turn on the radio: Turn the Power/Volume Control Knob clockwise until a “click” is heard.
2. Adjust the volume: Turn the Power/Volume Control Knob to adjust the volume. When function key is programmed with monitor feature, **turn the knob while holding down the function key to adjust the volume to a comfortable level.**
3. Select a Channel: Rotate Channel Selector knob to select your desired channel.
4. Transmit: **Hold down the [PTT] key**, speak into the microphone with normal voice. Keep microphone about 5cm away from your mouth.
5. Receive: Release **the [PTT] key**, the radio returns to receive mode.

Note: when battery voltage becomes too low, transmission will stop and radio LED flashes red. Please refer to “**Low Battery Alert**” for more details.

Time-Out-Timer (TOT)

The Time-Out-Timer (TOT) is used to prevent someone from using the same channel for a long time and to prevent the radio from damage due to continuous transmission.

If the transmission exceeds the preset time (it’s set by your dealer), transmission will be **inhibited** and a beep tone will sound. To stop the beep tone, release the **[PTT] key**. Press the **[PTT] key** again to **resume transmitting**.

■ TOT Reset Time

When this feature is **activated**, TOT won’t reset until **the preset TOT Reset Time** (it’s set by your dealer) expires, even if you have released the **[PTT] key**.

■ TOT Rekey Time

TOT Rekey Time is the duration that transmission is resumed after being inhibited by TOT. **When this feature is activated**, transmission will remain **inhibited** until **the preset TOT Rekey Time** (it’s set by your dealer) expires, even if you have pressed the **[PTT] key**.

■ TOT Pre-Alert

Your dealer can program a TOT Pre-Alert feature to alert you just before the TOT expires.

When this feature is activated, the radio will sound an alert tone at the preset TOT Pre-Alert time (1-255s before the TOT expires). Transmission will be inhibited by TOT after this time.

Battery Save

The Battery Save feature is enabled by your dealer to minimize the power consumption.

When there is no activity on the channel and no operation is performed for 10 seconds, the Battery Save feature is automatically activated. When a signal is received or an operation is performed, the Battery Save feature is automatically deactivated.

Low Battery Alert

Low Battery Alert alerts you to recharge or replace the battery. During transmission, when the battery voltage goes below a preset value, the LED indicator will flash red. When the alert tone sounds, the radio stops transmitting. Please recharge or replace the battery.

Monitor

This feature is enabled/disabled by your dealer. In receive mode, press the preprogrammed MONI key to monitor activities on the current channel. This operation is especially useful for adjusting volume level or receiving a weak signal. The LED indicator glows green in monitor mode.

Programmable Function Key

This key can be programmed as a shortcut to Monitor or High/Low Power feature, or set inactive through the programming software. 3 types of key pressing can be defined:

- **Short Press**—quickly press and release the key within 1 second
- **Long Press**—press and hold the key for more than 1 second
- **Press**—press the key in any manner

High/Low Power

This feature is enabled/disabled by your dealer. In receive mode, press the **preprogrammed High/Low Power key** to toggle between high and low power. Three beeps alternating from high tone to low tone indicate that the transmit power is switched from high to low; and three beeps alternating from low tone to high tone indicate that the transmit power is switched from low to high.

Compatible Channel Bandwidth

The dealer can select wideband or narrowband channel bandwidth via PC programming software.

2-Tone Encode & Decode

When 2-Tone signalling is set, press the function key while holding down the [PTT] key to transmit the 2-Tone code. **2-Tone decode and CTCSS/DCS decode can be set to one of the two signalling logics (“AND”/ “OR”) to achieve Selective Call feature (set by your dealer).** Parameter settings are made through PC programming software.

DTMF ANI

This feature is enabled/disabled by your dealer. **DTMF ANI is encoded by PTT ID.** Each radio is assigned with one ANI code consisting of **BOT ID (Beginning of Transmission)** and **EOT ID (End of Transmission)**. Each channel can be programmed by PC programming software to transmit/not transmit ANI code in transmit mode.

CTCSS/DCS Signalling

CTCSS/DCS may have been programmed on a channel to ignore unwanted calls from other parties on the same channel. When CTCSS/DCS signaling is set, user will receive the calls on the same channel only when the received signals contain the matching CTCSS/DCS code; otherwise, the user receives all the calls on the same channel within communication range.

The dealer can preset CTCSS/DCS signalling on all or just certain channels.

Note: Although using CTCSS/DCS enables you to avoid hearing unwanted calls, it does not mean your calls will be private.

Signalling AND/OR Logic

Signalling "AND"/"OR" sets the audio unmute condition for any channel programmed with 2-Tone or CTCSS/DCS.

2-Tone AND CTCSS/DCS:

The squelch opens only when both 2-Tone and CTCSS/DCS are received and matches the preset one on selected channel.

2-Tone OR CTCSS/DCS:

The squelch opens when either 2-Tone or CTCSS/DCS is received and matches the preset one on selected channel.

Channel Scan

■ Priority Channel Scan

Any programmed channel may be set as the priority channel. The radio will check the priority channel periodically while stopping on a non-priority channel. When there is any activity on the priority channel, the radio will automatically switch to the priority channel for communications.

■ Scan Revert Channel

If the radio is scanning and you press the [PTT] key, it will transmit on the preprogrammed revert channel. The revert channel can be programmed by your dealer.

Busy Channel Lockout

If the Busy Channel Lockout feature is enabled by your dealer, it will prevent you from talking on a channel that is already in use. When you press the [PTT] key, the radio will sound a beep tone and will not transmit. Release the [PTT] key to stop the beep tone.

Wait until the channel is not in use before you again try to transmit.

Troubleshooting Guide

Trouble	Solution
No power	<ul style="list-style-type: none"> ● Battery is low. Recharge or replace the battery. ● The battery may not be properly installed. Remove the battery and attach it again.
Power doesn't last long even if fully charged	<ul style="list-style-type: none"> ● Battery has lost its capacity, replace it with a new one.
Can't talk to or hear group members	<ul style="list-style-type: none"> ● Make sure you are using the same frequency, same CTCSS/DCS and same 2-Tone as your group members. ● Your group members may be out of the communication range.
Other voice (non-group members) are present on the channel	<ul style="list-style-type: none"> ● Change CTCSS/DCS tone. Make sure your group members all change to the same tone.

Care and Cleaning

- ◇ Do not carry your radio by the antenna or remote microphone;
- ◇ Wipe the battery contacts with a lint-free cloth to remove dirt, grease, or other material that may prevent good electrical connection;
- ◇ When not in use, keep the accessory jacks covered with the protective caps;
- ◇ Clean the shell, controls and keys of your radio with neutral detergent and warm water after a long period of usage. Avoid using strong chemicals.

Optional Accessories



Ni-MH Battery BH-T600A



Regular Charger (Ni-MH)



Earbud Style Ear Microphone ES-M1



Earholder Style Ear Microphone (with tube) EH-M2



Earholder Style Ear Microphone EH-M3



Switching Power Supply



Remote Speaker Microphone SM-06M01

Frequency Chart

Model:

Serial Number:

Channel	Transmit Frequency	Transmit CTCSS/DCS	Receive Frequency	Receive CTCSS/DCS
1				
2				
3				
4				
5				
6				
7				
8				
9				
10				
11				
12				
13				
14				
15				
16				

HYT endeavors to achieve the accuracy and completeness of this manual.

All the above specifications and design are subject to change by HYT without notice.

All the reproduction and translation of this manual without authorization of HYT is not allowed.