

THANK YOU!

Thank you for your purchase of HYT mobile radio TM-600. We believe this easy-to-use radio will provide you with dependable and reliable communications at peak efficiency. Please read this manual carefully before use. The information presented herein will help you to derive maximum performance from your radio.

MODELS COVERED IN THIS MANUAL

TM-600 VHF Mobile Radio

TM-600 UHF Mobile Radio

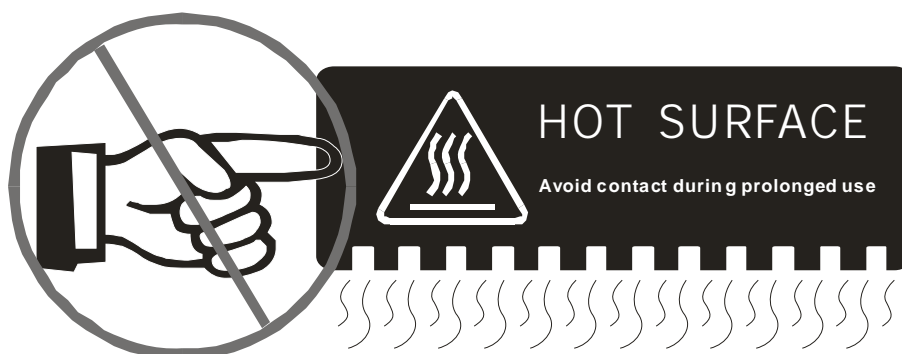

Do not touch the metal surface of the radio while it is in use.

Do not mount the radio such that the chassis can come in contact with skin.

High temperatures may burn you skin.

MANDATORY SAFETY INSTRUCTIONS TO INSTALLERS AND USERS

- Use Only manufacturer or dealer supplied antennas.
- Antenna minimum safe distance: 133cm .
- Antenna used for this transmitter must not exceed an antenna gain of **3dBi (for VHF and UHF)**.

The FCC (Federal Communications Commission) has adopted a safety standard for human exposure to RF energy which is below the OSHA (Occupational Safety and Health Act) limits.

- Antenna mounting: The antenna supplied by the manufacturer or radio dealer must not be mounted at a location such that during radio transmission, any person can come closer than the above indicated minimum safe distance to the antenna (i.e. 109cm).
- To comply with current FCC RF Exposure limitations, the antenna must be installed at or exceeding the minimum safe distance indicated above, and in accordance with the requirements of the antenna manufacturer or supplier.
- Vehicle installation: The antenna can be mounted at the center of a vehicle metal roof or

trunk lid if the minimum safe distance is observed.

Antenna substitution: Don't substitute any antenna for the one supplied or recommended by the manufacturer or radio dealer. You may be exposing person(s) to excessive radio frequency radiation. You may contact your radio dealer or the manufacturer for further instructions.

Warning

Maintain a separation distance from the antenna to person(s) at least 109cm .

“This transmitter is authorized to operate with a maximum duty factor of 50%, in a typical push-to-talk mode, for satisfying FCC RF exposure compliance requirements.”

Contents

Caution

MANDATORY SAFETY INSTRUCTIONS

User Safety, Training, and General Information

Compliance with RF Energy Exposure Standards

FCC Compliance

Precautions

Product Inspection

Radio Installation and Warnings

Radio Overview

Basic Operations

Radio Power On/Off

Adjust the Volume

Monitor

Select a Channel

Receive

Transmit

Programmable Power Output

BOT ID and EOT ID

Scan

Busy Channel Lockout (BCL)

BCL Override

DTMF Call

Code Squelch

Auto Transpond

Off Hook Decode

Time-out Timer (TOT)

Emergency Call

Programmable Auxiliary Functions

Reverse Frequency

Talk Around

Selectable Squelch Level

User Selectable CTCSS/DCS (UST)

Public Address (PA)

Dual Home Channel

2-Tone Encode Select

Compander

Scrambler

Optional Accessories

User Safety, Training, and General Information

READ THIS IMPORTANT INFORMATION ON SAFE AND EFFICIENT OPERATION BEFORE USING YOUR HYT MOBILE RADIO.

■ Compliance with RF Energy Exposure Standards

Your **HYT** mobile radio is designed and tested to comply with a number of national and international standards and guidelines (listed below) regarding human exposure to radio frequency electromagnetic energy. This radio complies with the IEEE and ICNIRP exposure limits for occupational/controlled RF exposure environment at operating duty factors of up to 50% transmitting and is authorized by the FCC for occupational use only. In terms of measuring RF energy for compliance with the FCC exposure guidelines, your radio radiates measurable RF energy only while it is transmitting (during talking), not when it is receiving (listening) or in standby mode.

Your HYT mobile radio complies with the following of RF energy exposure standards and guidelines:

- United States Federal Communications Commission, Code of Federal Regulations; 47CFR part 2 sub-part J
- American National Standards Institute (ANSI)/Institute of Electrical and Electronic Engineers (IEEE) C95. 1-1992
- Institute of Electrical and Electronic Engineers (IEEE) C95. 1-1999 Edition
- International Commission on Non-Ionizing Radiation Protection (ICNIRP) 1998

Operational Instructions and Training Guidelines

To ensure optimal performance and compliance with the occupational/controlled environment RF energy exposure limits in the above standards and guidelines, users should transmit no more than 50% of the time and always adhere to the following procedures:

Transmit and Receive

To transmit (talk), push the Push-To-Talk (PTT) button; to receive, release the PTT button

■ FCC Compliance

Part 15 Compliance

This equipment has been tested and found to comply with the limits for a Class B digital device, pursuant to part 15 of the FCC Rules. These limits are designed to provide reasonable protection against harmful interference in a residential installation. This equipment generates, uses and can radiate radio frequency energy and, if not installed and used in accordance with the instructions, may cause harmful interference to radio communications. However, there is no guarantee that interference will not occur in a particular installation. If this equipment does cause harmful interference to radio or television reception, which can be determined by turning the equipment off and on, the user is encouraged to try to correct the interference by one or more of the following measures:

Reorient or relocate the receiving antenna.

Increase the separation between the equipment and receiver.

Connect the equipment into an outlet on a circuit different from that to which the receiver is connected.

Consult the dealer or an experienced radio/TV technician for help.

FCC Licensing Requirements

Your radio must be properly licensed Federal Communications Commission prior to use. Your HYT Wireless dealer can assist you in meeting these requirements. Your dealer will program each radio with your authorized frequencies, signalling codes, etc., and will be there to meet your communications needs as your system expands.

Precautions

General Safety Standards

- * Do not attempt to configure the radio while driving; it is too dangerous.
- * Do not operate your radio when someone is either touching the antenna or standing within 2 or 3 feet of it, to avoid the possibility of radio frequency burns or related physical injury.
- * Do not operate the radio near dynamite blasting caps or in an explosive atmosphere.
- * Switch OFF the radio while refueling or parking at gas station.
- * Turn off your radio in any place where posted notices instruct you to do so.
- * Do not modify the radio for any reason.

- * Do not expose the radio to direct sunlight over a long time, nor place it close to heating source.
- * Do not place the radio in excessively dusty, humid areas, nor on unstable surfaces.
- * Refer service to qualified technicians only.

Operation Safety Guidelines

- * For vehicles equipped with electronic anti-skid braking systems, electronic ignition systems or electronic fuel injection systems, interferences may occur during the radio transmission. If the foregoing electronic equipments are installed on your vehicle, please contact your dealer for further assistance to make sure that the radio transmission will not interfere with these equipments.
- * For radio installation in vehicles fueled by LP gas with LP gas container within interior of the vehicles, the following precautions are recommended for personal safety.
 - (1) Any space containing radio equipment shall be isolated by a seal from the space in which the LP gas container and its fittings are located.
 - (2) Remote (outside) fitting connections shall be used.
 - (3) Good ventilation is required for the container space.

Safety: It is important that the operator is aware of, and understands, hazards common to the operation of any radio.

Installation Safety Guidelines

- * Do not mount the mobile radio overhead or on a sidewall unless you take special precautions.
- * If someone were to remove the radio and fail to replace it properly, road shock could bump the radio loose, and the falling radio could, in some circumstances, cause serious injury to the driver or a passenger. In a crash, even when properly installed, the radio could break loose and become a dangerous projectile.

Product Inspection

Please carefully unpack the radio. Before use, it is recommended that you inspect the product as follows.

First check the shipping carton for any signs of damage. Confirm the supplied product against the packing slip to assure accuracy. If any items are missing or have been damaged during shipment, please file a claim to the carrier immediately.

■ Supplied Accessories

Item	Quantity (pcs)
DC Power Cable	1
Mounting Bracket	1
Remote speaker microphone	1
Microphone hanger	1
Microphone hanger screw	3
Adjust knobs	4
Bracket mounting screw set	6
Fuse	2
Owner's Manual	1



Remote Speaker
Microphone (SM11R1)



Microphone Hanger



Microphone
Hanger Screw



Mounting bracket



Adjust knobs



Mounting screw set



Fuse



Power cable

Radio Installation

■ Installing the Radio

- 1、 Attach the mounting bracket, using the 4.8 x 20mm self-tapping screws, in a location where convenient operation is accessible.
- 2、 Connect the antenna and the supplied power cable to the radio.
- 3、 Slide the radio into the mounting bracket and secure it using the Adjustment knobs.
- 4、 Mount the microphone hanger, using the 4 x 16mm self-tapping screws, in a location where it will be within easy reach of the user.
- 5、 Connect the microphone plug to the microphone jack on the front panel of the radio, then place the microphone on the hanger.

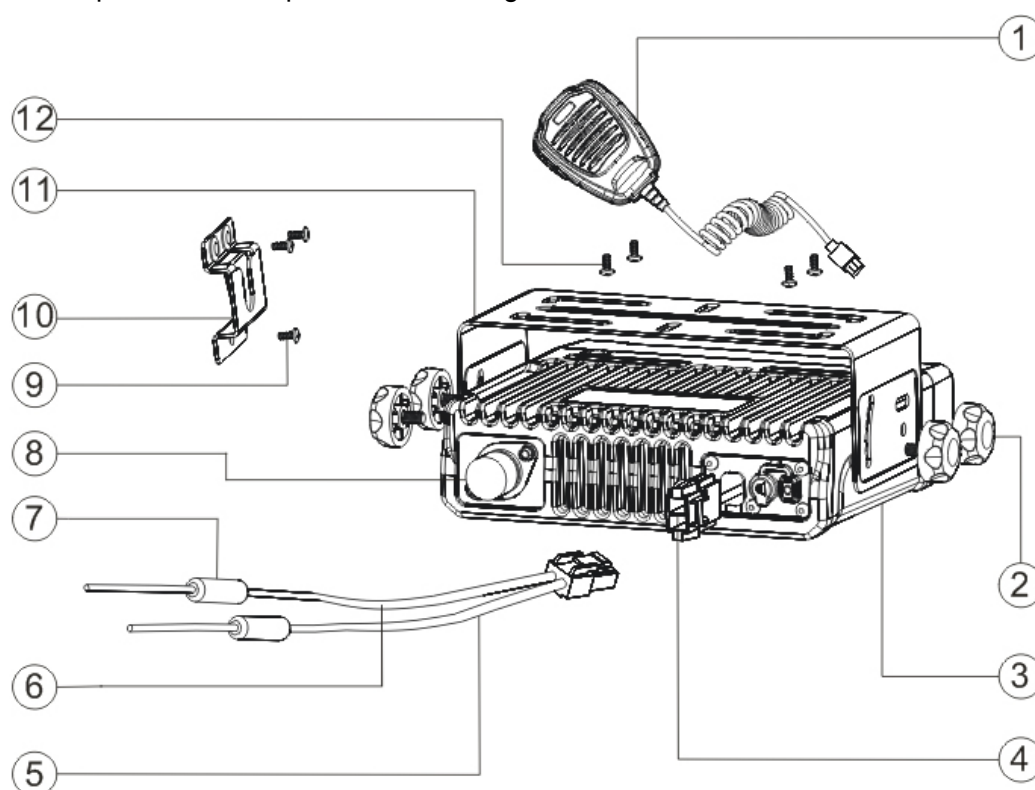

1. Remote speaker microphone
2. Adjust knob
3. Main unit
4. Power inlet
5. Black lead
6. Red lead
7. Fuse
8. Antenna pedestal
9. 4 ×16mm self-tapping screw
10. Remote speaker microphone hanger
11. Mounting bracket
12. 4.8 × 20mm self-tapping screw

■ Installation Tools

1. Electric drill: $\phi 6$ mm or above
2. Cross head screwdriver
3. Hex socket (used to fix 4.8 × 20mm self-tapping screws)

■ Warnings:

- * The radio operates in **13.6 ± 15%V** negative ground systems only. Check the voltage and polarity of the power supply on the vehicle before installation.
- * Be sure to check how far the screw will extend below the radio surface to avoid damage to the auto wiring or auto parts when drilling mounting holes.
- * Connect the radio with the supplied antenna and power cable before installing the radio by the mounting bracket.
- * Install the radio securely using the supplied mounting bracket to make sure that the radio will not loosen in the event of accidents. The loose radio may cause injury to the passenger.
- * Arrange the installation location of the radio to make sure that the control unit in the front panel is convenient for operation.
- * Be sure to determine the location of the installing holes before installation and drilling.
- * Be sure to make room at the rear side of the radio for power cable connection.
- * When replacing the fuse in the DC power cable, be sure to replace it with a fuse of the same specifications. Never replace a fuse with one that has a higher capacity value.

Radio Overview

■ Front Panel View

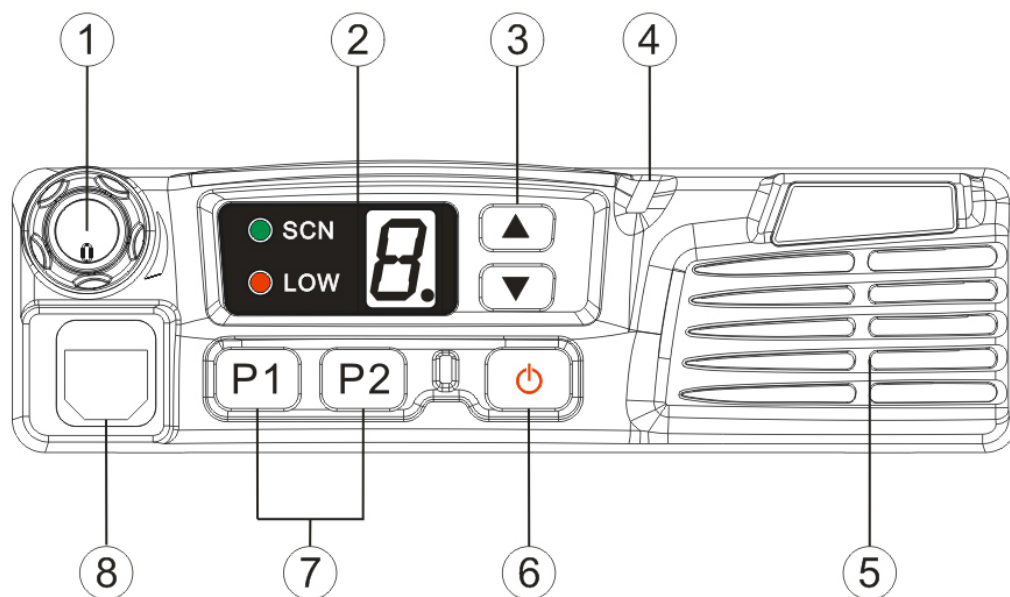

① Volume Knob

Turn the knob clockwise to adjust upwards and counterclockwise to adjust downwards.

② LED Indicator & 8-segment Numeric Display

Please refer to the “LED status indicator and 8-segment numeric display” section.

③ Programmable Function Key (▲/▼)

Your dealer can program these keys as shortcuts to various radio features.

Please refer to “Programmable Function Key” section.

④ LED Tx-Rx Indicator

⑤ Speaker

⑥ Power Switch

⑦ Programmable Function Key (P1/P2)

Your dealer can program these keys as shortcuts to various radio features.

Please refer to “Programmable Function Key” section.

⑧ Microphone Jack

Insert the microphone plug into this jack.

■ Rear Panel View

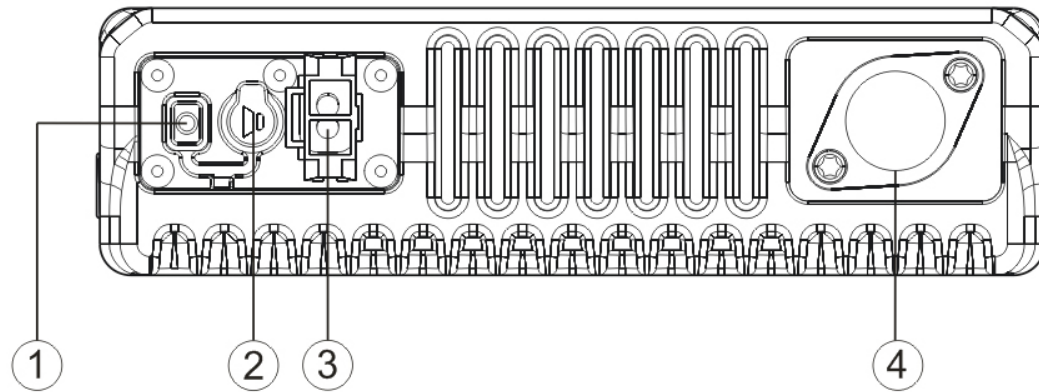

① 15PIN (external expansion)

② External Speaker Jack

Used to connect external speaker, for the 3.5mm plug

③ Power inlet

Use HYT supplied DC power cable to access 13.6V DC power.

④ Antenna Pedestal

Used to connect external antenna.

■ LED Indicators

Name	Display	Radio Status
Tx-Rx indicator	Red	Transmit a signal
	Green	Receive a signal
	Orange flash	Receives encode squelch, selcall, 2-Tone/DTMF signalling call
SCN indicator	Green	Scan
LOW indicator	Red	Lit up for low power, goes out for high power

■ 8-Segment Numeric LED



Figure 1 8-segment Numeric LED

■ Programmable Function Keys

P1/P2, ▲/ ▼ is programmable for the following functions:

1. Off
2. Channel Up
3. Channel Down
4. Monitor A
5. Monitor B
6. Monitor C
7. Monitor D
8. User Selectable Tone
9. 2-Tone encode Select
10. Tx Power Select
11. Scan
12. Add/Del
13. Reverse Frequency
14. Talk Around
15. Selects squelch level

16. Home channel
17. Public address
18. Scrambler
19. Compander
20. Emergency Call

Basic Operations

Radio Power On/Off

Press the power switch to turn on the radio.

Press and hold down the power switch for about 1 second to turn off the radio.

Adjust the Volume

Turn the Volume Control Knob clockwise to increase the volume, or counter-clockwise to decrease the volume.

Note:

1. If the radio is programmed with CTCSS/CDCSS, 2-Tone signalling squelch, no noise will be heard from the speaker even though at maximum volume level.
2. Holding down the Monitor key (Monitor C/D) simultaneously while adjusting volume level, to hear the current volume level from the speaker.

Monitor

If the Monitor function is set by your dealer, press the Monitor key (programmable) while in receive mode, to monitor activities on the current channel.

The Monitor key is programmable with one of the following four operating modes by your dealer:

1、Monitor Unmute-Momentary

Hold down the [MONI] key to open CTCSS/CDCSS/2-Tone signalling squelch. Release to close the signalling squelch.

2、Monitor Unmute-Toggle

Press the [MONI] key to open CTCSS/CDCSS/2-Tone signalling squelch. Press again to close the signalling squelch.

3、Carrier Squelch-Momentary

Hold down the [MONI] key to open carrier squelch; Release to close the carrier squelch.

4、Carrier Squelch-Toggle

Press the [MONI] key to open carrier squelch. Press again to close the carrier squelch.

Select a Channel

The ▲/▼ or P1-P2 function keys are programmable by your dealer to select a channel.

The Rx/Tx frequency on each channel is set by your dealer.

Press the [Channel Up] key (programmable) to select a higher numbered channel; press the [Channel Down] key to select a lower numbered channel.

Receive

If CTCSS/CDCSS, 2-Tone has been programmed on the current channel by your dealer, you can receive calls with matched tones or codes only. If CTCSS/CDCSS, 2-Tone is not set, you can hear from all the users on the same channel.

Transmit

1. Hold down the [PTT].
2. Dial DTMF number via microphone keypad. (This operation may be unnecessary).
3. Speak into the microphone. The LED is red while calling.
4. Release the [PTT] to return to the receive mode.
5. When transmission ends, put the microphone on hook.

Programmable Power Output

If the current channel is programmed with high power by your dealer, the power output toggles between high and low upon each press the Tx Power Select key (programmable). Low power is for battery saving and avoiding interference with other users, low power is recommended when communication within limited range.

Note:

- If the current channel is programmed with low power, press the Tx Power Select key, an error alert tone is heard while the power output will not change.
- If you switch to low power on a channel that was set with high power, this configuration is done on all other channels that were set with high power.

BOT ID and EOT ID

Your dealer may configure whether to transmit Connect ID (BOT ID) and Disconnect ID (EOT ID), when connecting or disconnecting a repeater or telephone system. The following modes are programmable:

- 1、 BOT ID occurs on each press of [PTT].
EOT ID occurs on each release of [PTT].
- 2、 Press the [*] while holding down the [PTT], then BOT ID is transmitted.
Pres the [#] while holding down the [PTT], then EOT ID is transmitted.

Scan

Radio scans all the channels that have been added into the scan list of the current zone.

■ Scan Start

- ① Add one or several non-priority channels into the scan list.
- ② Press the Channel Scan key (programmable) to initiate scan from the current channel, then scanning proceeds in ascending order by channel number, while the scan LED lit up.

■ Scan Cease

Scanning pauses or ceases upon the following:

1. Upon repress the Channel Scan key (programmable), scanning ceases, scan LED goes out, then radio exit the scan mode.
2. Activate the Monitor function.
3. Carrier is detected on a channel that is not set with signalling.
4. Carrier is detected and match signalling is received on a channel that is set with signalling.

■ Scan Resume

If scanning pauses on an active channel, the scanning will resume according to the scan resume mode. The scan resume mode is programmable by your dealer for Carrier operated scan or Time operated scan.

1. Time operated scan

Scanning remains on an active channel for a programmed time period (programmable by your dealer), once the timer expires, the radio will begin scanning other channels even if the active channel is still busy.

2. Carrier operated scan

If carrier is detected during the scan sequence, scanning will remain on the active channel until there is no activity.

■ Dual Priority Scan

If dual priority channels are programmed by your dealer, the radio still checks the dual priority channels for activity at configured intervals, while scanning pauses on a non-priority channel. When any activity is detected on a priority channel, the radio will immediately switch to the active priority channel.

■ Nuisance Channel Temporary Delete

Temporarily delete the selected channel from the scan list during scanning.

When scan pauses on an unwanted channel due to noise, press the Add/Del Scan key (programmable) to temporarily delete the channel from the scan list. Then scan is reactivated immediately.

Note: the temporary delete is not memorized once radio exits from the scan mode.

■ Revert Channel

Upon pressing the [PTT] during scanning, the radio will pause scanning and switch to the Revert Channel to transmit. This feature is programmable by your dealer.

■ Off-Hook Scan

If the Off-Hook Scan feature is programmed by your dealer, radio scans no matter the microphone is in the off or on hook condition. Otherwise, microphone must be on hook for scanning.

Busy Channel Lockout (BCL)

The feature can be enabled/disabled by your dealer, this feature is to prevent transmission on a channel that is already in use. Press the [PTT] on a channel that is already in use, transmission is inhibited and an alert tone is heard. Upon release the [PTT], the alert tone ceases and radio returns to receive mode. Press the [PTT] to transmit while the channel is free.

BCL Override

If the BCL Override feature is enabled, you can override the BCL feature to transmit on a busy channel. Press the [PTT], a BCL alarm will be heard, then repress the [PTT] within 0.5s to override the BCL feature and transmit on the busy channel.

DTMF Call

■ Manual Dial

Press any key from the DTMF keypad of the microphone, while holding down the [PTT], to transmit the DTMF frequency, and the DTMF tone will be heard from the local speaker. Release the [PTT] to remain transmission for 2s (programmable by your dealer), press a numeric key within the 2s to continue transmission.

■ Keypad Auto PTT

This feature is programmable by your dealer. If the feature is enabled, press numeric key to transmit DTMF frequency without pressing the [PTT].

■ DTMF Speed

6, 8, 10 or 15 digits per second is programmable by your dealer. The feature is designed to reduce false decoder operation by providing a fixed time period between digits.

■ Auto Dial

1. Press the [*] on the Mic keypad.
2. Enter the pre-stored DTMF code location number (1~9).
3. LED displays the location number (1.~9.).
4. Press the [PTT] to transmit the stored number.

■ Redial

1. Press the [*] on the mic keypad.
2. Then press the [0].
3. LED displays 0.
4. Press the [PTT] to transmit the last dialed number (max. 16 digits).

Note: the redial memory is cleared once the radio is turned off.

Code Squelch

This feature can be enabled/disabled via programming by your dealer. If the feature is enabled, the preset 2-Tone controls radio mute/unmute. The radio will not unmute until matched signalling is received.

■ Receive

1. Radio is unmuted when matched 2-Tone signalling (programmed by your dealer) is received, the user can hear from the transmitter without any other operation.
2. LED flashes orange.
3. Radio is muted upon press the Monitor key (programmable), or no signal is received within the preset time period.
4. If the Alert Tone is enabled, radio will emit alert when matched signalling is received. If the Transpond is enabled, radio will transpond a signal to the calling radio. However, radio will no transpond if a group call is received.

■ Transmit

1. Holding down the [PTT].
2. Enter the preset DTMF encode (radio encode or group encode) via keypad.

The further operations are the same as that of normal mobile radios.

Red LED lit up while in transmission.

Please refer to the [TTS] key for 2-Tone transmission.

3. Upon release the [PTT], the signalling squelch is disabled and LED flashes orange.
Green LED lit up when signal is received.
4. If the Monitor key (programmable) is pressed, or no signal is received within the preset time period, the signalling squelch is enabled.

Auto Transpond

The Auto Transpond feature can be programmed by your dealer to operate with Code Squelch. If the Auto Transpond feature is enabled, radio will automatically transpond a signal when a call with matched signalling is received. Your dealer may program one type of call response from the following:

1. Alert
2. Transpond
3. Alert & Transpond

Press any key to stop transpond.

Off Hook Decode

If the feature is enabled by your dealer, CTCSS/CDCSS decode signalling is active no matter the microphone is in the off/on hook condition. If the feature is disabled, CTCSS/CDCSS decode signalling is disabled while the microphone is in the off hook condition.

Time-out Timer (TOT)

■ Time-out Timer (TOT)

The TOT feature is to prevent user from transmitting on the channel for extended period of time. This also protects the radio from damage caused by long time transmission.

Once a continuous transmission exceeds the preset time (15~1200s programmable), the transmission is automatically terminated and alert tone is heard. The alert tone ceases upon release the [PTT].

The TOT default is 180s, it meets normal operation needs. Any change should be permitted by professional technicians.

■ TOT Pre-alert

The radio has a TOT Pre-alert timer. The radio will emit the Pre-alert tone at the programmed time (1~10s before the TOT timer expires).

■ TOT Re-key Time

The radio has a TOT Re-key timer. Since transmission is terminated upon the TOT timer expires, transmission is inhibited if press the [PTT] before the expiration of TOT Re-key timer (programmable by your dealer as Off, 1~60s).

■ TOT Reset Time

Upon the press of [PTT], "TOT" begins timing. After the release of [PTT], "TOT" reset timer begins timing, However, the TOT timer will not reset until the TOT Reset timer expires.

The TOT Reset Time is programmable by your dealer as Off, 1~15s.

Emergency Call

Holding down the Emergency Call key (programmable as long or short press), the radio will enter the Emergency Call mode and switch to the preset Emergency Channel. The radio will firstly transmit within the preset time period, and then receive within the preset time period, and so does the cycle.

The radio will back to the channel before the Emergency Call mode, upon re-holding down the Emergency Call key (programmable as long or short press).

Programmable Auxiliary Functions

The [P1]-[P2], ▲/▼ are respectively programmable with one of the following auxiliary functions by your dealer.

Reverse Frequency

If communications between radios are disrupted because of a long distance from the repeater, the Reverse Frequency function can be used to re-establish communications with another radio. When the function is activated, the transmit frequency and receive frequency will be reversed. The preset CTCSS/CDCSS encoding and decoding signals will also be reversed.

Press the Reverse Frequency key (programmable) to toggle the Reverse Frequency function ON or OFF.

Talk Around

If the Talk Around feature is enabled, the Rx frequency is used in place of the Tx frequency when transmitting, and the CTCSS/CDCSS decoding signal is used in place of the encoding signal when encoding.

Press the Talk Around key (programmable) to toggle the Talk Around function ON or OFF.

Selectable Squelch Level (SQL)

- 1、 Upon press the SQL key (programmable), LED displays the current squelch level.
- 2、 Select the desired squelch level via the programmable key ▲/ ▼.
- 3、 Upon press the [P1] or [P2] key (programmable), LED resets to the original display mode.

Note: High squelch level may cause the radio to ignore weak signals; while low squelch level may cause noise or unwanted signals to be heard.

User Selectable CTCSS/DCS (UST)

If the UST feature is enabled by your dealer, the user can temporarily change the CTCSS/CDCSS codes that preset on the channel.

1. Select a desired channel.
2. Press the [UST] key (programmable) to enter the UST mode.
3. Use the ▲/ ▼ key to select a desired UST code (the newly selected CTCSS/CDCSS code is valid in the UST mode only), then the CTCSS/CDCSS code on the current channel is set as the selected UST code.

4. Repress the [UST] key to exit the UST mode, then LED resets to the original display mode.

Public Address (PA)

The PA feature amplifies audio inputted from the microphone, and the audio can be heard from the external speaker which is connected via 15PIN expansion port.

1. Press PA key (programmable) to activate the PA feature, then the LED displays “P”.
Repress the PA key to disable the PA feature, then the radio returns to normal user mode.
2. Once the PA feature is activated, the radio is unable to transmit and receive.
3. Speak into the microphone while holding down the [PTT], your voice can be heard from the external speaker that is connected to the radio.
While in PA mode or the PA process initiates, the user can adjust volume via the volume control knob.
4. Release the [PTT] to end PA process, then the radio returns to the PA mode.

Note:

- In PA mode, adjust volume via the volume control knob.
- While using the PA system, the optional PA accessories and external speaker must be installed by your dealer.

Dual Home Channel

Upon press the Home Channel key (programmable), the radio will promptly go to the programmed home channel.

When dual home channels are set, press the programmed Home Channel key to promptly go to Home Channel 1, press again to promptly go to Home Channel 2, and press for the third time to return to the original channel.

2-Tone Encode Select

1. Press the 2-Tone Encode Select key (programmable), local LED displays the preset 2-Tone encode sequence (0~9).
2. Press the ▲/ ▼ key to select 2-Tone encode (0~9).
3. Holding down the [PTT] to transmit the selected 2-Tone encode.
4. Upon release the [PTT], the signalling squelch is disabled and LED flashes orange.
5. If the Monitor key is pressed, or no signal is received within the preset time period, the signalling squelch is enabled.

Note: If no signal is received within the preset time period, the signalling squelch is enabled.

Comander

Press the Comander key (programmable) to toggle the comander feature ON or OFF.

Scrambler

Press the Scrambler key (programmable) to toggle the Scrambler feature ON or OFF.

Note: The emphasis/de-emphasis feature is disabled while the Scrambler is ON, and enabled while the Scrambler is OFF.

Key Assignment

Programmable function keys [P1]-[P2], ▲/▼.

Key Assignment				
No	Function keys	Setting	Display	Remarks
1	[P1]	Off	1 CH Number	No function
		CH Up	2 CH Number	Channel Up
		CH Down	3 CH Number	Channel Down
		MONI A	4 CH Number	MONI A: Carrier Squelch-momentary
		MONI B	5 CH Number	MONI B: Carrier Squelch-toggle
		MONI C (default)	6 CH Number	MONI C: Squelch off-momentary
		MONI D	7 CH Number	MONI D: Squelch off -toggle
		User Selectable Tone	8 UST Number (0.-9.)	CTCSS/DCS Tone
		Sel 2Tone	9 2Tone Number (0.-9.)	Select 2-Tone encode
		TX power Select	10 CH Number	Switch transmit power
		Scan	11 ●	Scan
		Add/Del	12 ●	Temporarily delete nuisance channel
		Reverse Freq	13 CH Number	Reverse frequency
		Talk Around	14 CH Number	Talk Around
		SEL SQL	15 SQL Number (0. -9.)	Select squelch level
		Home CH	16 HomeCH Number(1-8)	Home Channel
		Public Address	17 P	Public address

		Scrambler	18 CH Number	Scrambler
		Compander	19 CH Number	Compander
		Emergency Call	20 EmergencyCH Number (1- 8)	Emergency call
2	[P2]	Off	1 CH Number	No function
		CH Up	2 CH Number	Channel Up
		CH Down	3 CH Number	Channel Down
		MONI A	4 CH Number	MONI A: Carrier Squelch-momentary
		MONI B	5 CH Number	MONI B: Carrier Squelch-toggle
		MONI C	6 CH Number	MONI C: Squelch off-momentary
		MONI D	7 CH Number	MONI D: Squelch off -toggle
		User Selectable Tone	8 UST Number (0. -9.)	CTCSS/DCS Tone
		Sel 2Tone	9 2Tone Number (0. -9.)	Select 2-tone encode
		TX Power Select	10 CH Number	Switch transmit power
		Scan (default)	11 •	Scan
		Add/Del	12 •	Temporarily delete nuisance channel
		Reverse Freq	13 CH Number	Reverse frequency
		Talk Around	14 CH Number	Talk around
		SEL SQL	15 SQL Number (0. -9.)	Select squelch level
		Home CH	16 HomeCH Number (1- 8)	Home channel
		Public Address	17 P	Public address
		Scrambler	18 CH Number	Scrambler

		Compander	19 CH Number	Compander
		Emergency Call	E20 EmergencyCH Number (1- 8)	Emergency call
3	▲ ([UP])	Off	1 CH Number	No function
		CH Up (default)	2 CH Number	Channel Up
		CH Down	3 CH Number	Channel Down
		MONI A	4 CH Number	MONI A: Carrier Squelch-momentary
		MONI B	5 CH Number	MONI B: Carrier Squelch-toggle
		MONI C	6 CH Number	MONI C: Squelch off-momentary
		MONI D	7 CH Number	MONI D: Squelch off -toggle
		User Selective Tone	8 UST Number(0. -9.)	CTCSS/DCS Tone
		Sel 2Tone	9 2Tone Number(0. -9.)	Select 2-Tone encode
		TX Power Select	10 CH Number	Switch transmission power
		Scan	11 •	Scan
		Add/Delete	12 •	Temporarily delete nuisance channel
		Reverse Freq	13 CH Number	Reverse Frequency
		Talk Around	14 CH Number	Talk around
		SEL SQL	15 SQL Number(0. -9.)	Select squelch level
		Home CH	16 HomeCH Number (1-8)	Home channel
		Public Address	17 P	Public address
		Scrambler	18 CH Number	Scrambler
		Compander	19 CH Number	Compander

		Emergency Call	20 EmergencyCH Number (1- 8)	Emergency Cal
4	▼ ([DOWN])	Off	1 CH Number	No function
		CH Up	2 CH Number	Channel Up
		CH Down (default)	3 CH Number	Channel Down
		MONI A	4 CH Number	MONI A: Carrier Squelch-momentary
		MONI B	5 CH Number	MONI B: Carrier Squelch-toggle
		MONI C	6 CH Number	MONI C: Squelch off-momentary
		MONI D	7 CH Number	MONI D: Squelch off -toggle
		User Selective Tone	8 UST Number(0. -9.)	CTCSS/DCS Tone
		Sel 2Tone	9 2Tone Number(0. -9.)	Select 2-Tone encode
		TX Power Select	10 CH Number	Switch transmission power
		Scan	11 •	Scan
		Add/Delete	12 •	Temporarily delete nuisance channel
		Reverse Freq	13 CH Number	Reverse Frequency
		Talk Around	14 CH Number	Talk around
		SEL SQL	15 SQL Number(0. -9.)	Select squelch level
		Home CH	16 HomeCH Number(1-8)	Home channel
		Public Address	17 P	Public address
		Scrambler	18 CH Number	Scrambler
		Compander	19 CH Number	Compander
		Emergency Call	20 EmergencyCH Number (1- 8)	Emergency Call

5	Selector Knob	Volume Knob	CH Number	Volume Knob
---	---------------	-------------	-----------	-------------

Note: the above "CH Number" can be any value among "1 – 8".

Optional accessories



Antenna



Remote Speaker Microphone with Keypad (SM07R1)



Programming Cable (PC06)



Clone Cable (CP06)

HYT endeavors to achieve the accuracy and completeness of this manual, but cannot guarantee its accuracy at all time. All the above specifications and design are subject to change by HYT without notice.

All the reproduction and translation of this manual without authorization of HYT is not allowed.