

SAFETY TRAINING INFORMATION



Your **HYT** radio generates RF electromagnetic energy during transmit mode. This radio is designed for and classified as “Occupational Use Only”, meaning it must be used only during the course of employment by individuals aware of the hazards, and the ways to minimize such hazards. This radio is **NOT** intended for use by the “General Population” in an uncontrolled environment.

This radio has been tested and complies with the FCC RF exposure limits for “Occupational Use Only”. In addition, your **HYT** radio complies with the following Standards and Guidelines with regard to RF energy and electromagnetic energy levels and evaluation of such levels for exposure to humans:

- FCC OET Bulletin 65 Edition 97-01 Supplement C, Evaluating Compliance with FCC Guidelines for Human Exposure to Radio Frequency Electromagnetic Fields.
- American National Standards Institute (C95.1-1992), IEEE Standard for Safety Levels with Respect to Human Exposure to Radio Frequency Electromagnetic Fields, 3 kHz to 300 GHz.
- American National Standards Institute (C95.3-1992), IEEE Recommended Practice for the Measurement of Potentially Hazardous Electromagnetic Fields— RF and Microwave.
- The following accessories are authorized for use with this product. Use of accessories other than those (listed in the instruction) specified may result in RF exposure levels exceeding the FCC requirements for wireless RF exposure.



To ensure that your exposure to RF electromagnetic energy is within the FCC allowable limits for occupational use, always adhere to the following guidelines:

- **DO NOT** operate the radio without a proper antenna attached, as this may damage the radio and may also cause you to exceed FCC RF exposure limits. A proper antenna is the antenna supplied with this radio by the manufacturer or antenna specifically authorized by the manufacturer for use with this radio.
- **DO NOT** transmit for more than 50% of total radio use time (“50% duty cycle”). Transmitting more than 50% of the time can cause FCC RF exposure compliance requirements to be exceeded. The radio is transmitting when the “TX indicator” lights red. You can cause the radio to transmit by pressing the “PTT” switch.

- **ALWAYS** keep the antenna at least 150 cm away from the body when transmitting

The information listed above provides the user with the information needed to make him or her aware of RF exposure, and what to do to assure that this radio operates with the FCC RF exposure limits of this radio.

Electromagnetic Interference/Compatibility

During transmissions, your **HYT** radio generates RF energy that can possibly cause interference with other devices or systems. To avoid such interference, turn off the radio in areas where signs are posted to do so. **DO NOT** operate the transmitter in areas that are sensitive to electromagnetic radiation such as hospitals, aircraft, and blasting sites.

Occupational/Controlled Use

The radio transmitter is used in situations in which persons are exposed as consequence of their employment provided those persons are fully aware of the potential for exposure and can exercise control over their exposure.

IMPORTANT

READ ALL INSTRUCTIONS carefully and completely before using the transceiver

SAVE THIS INSTRUCTION MANUAL- This instruction manual contains important operating instructions for the Two-Way Radio

EXPLICIT DEFINITIONS

WORD	DEFINITION
WARNING	Personal injury, fire hazard or electric shock may occur.
CAUTION	Equipment damage may occur.
NOTE	If disregarded, inconvenience only. No risk of personal injury, fire or electric shock.

OPERATING NOTES

- When transmitting, Please Keep the antenna at least 150 cm from your head and body.

PRECAUTIONS

WARNING! NEVER hold the transceiver so that the antenna is very close to, or touching exposed parts of the body, especially the face or eyes, while transmitting. The transceiver will perform best if the microphone is 150 cm away from the antenna.

WARNING! NEVER operate the transceiver with a headset or other audio accessories at high volume levels.

DO NOT push the PTT when not actually desiring to transmit.

AVOID using or placing the transceiver in direct sunlight or in areas with temperatures below -30°C (-22°F) or above $+60^{\circ}\text{C}$ ($+140^{\circ}\text{F}$).

DO NOT modify the transceiver for any reason.

FCC CAUTION:

Changes or modifications to this device, not expressly approved by **HYT**, could void your authority to operate this transceiver under FCC regulations.

■ **Revision History**

P/N	Release Date	Revision
		Initial Release

■ **General**

Manual Scope

This manual is intended for use by experienced technicians familiar with similar types of communication equipment. It contains all service information required for the equipment and is current as of the publication date.

Safety and General Information

The following general safety precautions as would normally apply, should be observed during all phases of operation, service and repair of this equipment.

- ◇ This equipment should be serviced by qualified technicians only.
- ◇ Do not modify the repeater for any reason.
- ◇ To avoid electromagnetic interference and/or compatibility conflicts, do not operate your repeater when you are near 380V AC mains or above.
- ◇ For vehicles with an air bag, do not place a repeater in the area over an air bag or in the air bag deployment area. Air bags inflate with great force. If a repeater is placed in the air bag deployment area and the air bag inflates, the repeater may be propelled with great force and cause serious injury to occupants of the vehicle.
- ◇ Turn off your repeater prior to entering any area with a potentially explosive atmosphere.
- ◇ To avoid possible interference with blasting operations, turn off your repeater when you are near electrical blasting caps, in a blasting area, or in areas posted: "Turn off two-way radio." Obey all signs and instructions.
- ◇ Do not charge your back-up battery in a potentially explosive atmosphere
- ◇ Do not expose the repeater to direct sunlight over a long time, nor place it close to heating source.

- ◇ Do not place the repeater in excessively dusty, humid areas, nor on unstable surfaces
- ◇ Connect to the lightning arrester prior to the antenna which is installed outdoors, and the chassis or equipment housing must be connected to an absolute earth ground, to minimize any possible shock hazard from lightning strike.
- ◇ Please make sure no stress on the antenna joint during transportation or installation.

Caution:

This equipment generates, uses, and can radiate radio frequency energy and, if not installed or used in accordance with the owner's manuals, can cause interference to radio communications.

HYT endeavors to achieve the accuracy and completeness of this manual, but no warranty of accuracy or reliability is given. All the above specifications and design are subject to change without notice due to continuous development.

No part of this manual may be copied, reproduced, translated, stored in a retrieval system, distributed, or transmitted in any form or by any means, electronic or mechanical, for any purpose without the express written permission of HYT.

■ Brief Introduction

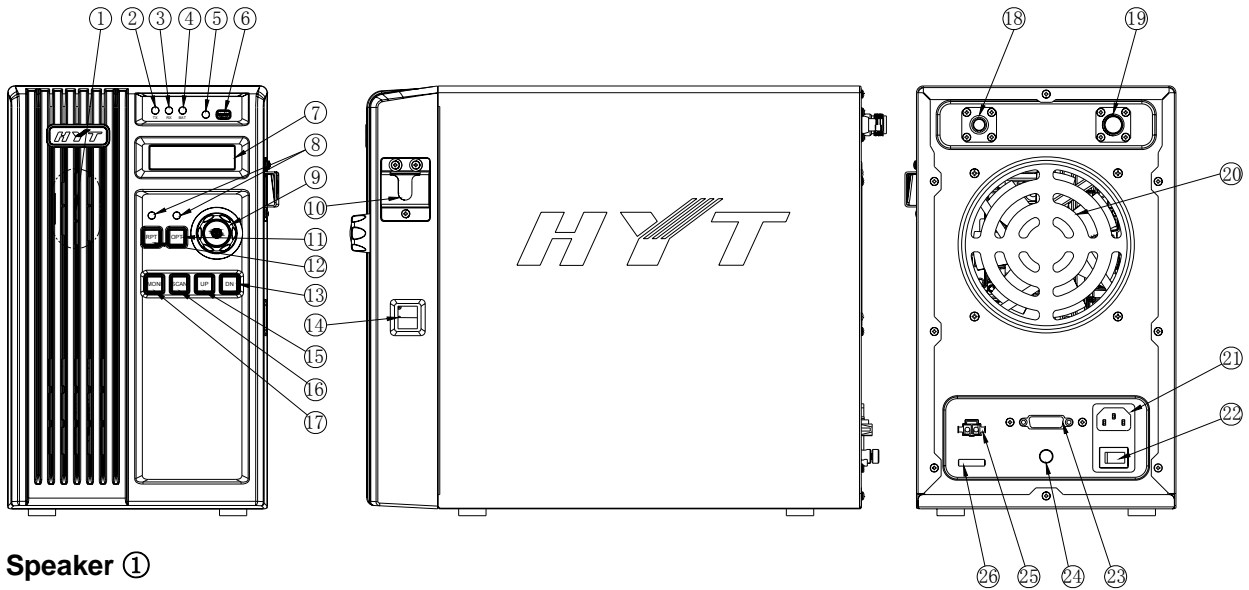

1. Speaker ①

2. LED Indicators

Red LED ② lights while the main radio is transmitting, and flashes while receiving.

Green LED ③ lights while the slave radio is transmitting, and flashes while receiving.

Dark red LED ④ lights while DC power supplies and the AC power fails.

Orange LED ⑤ lights while the repeater in setup state and goes out while in knockdown state.

Blue LED ⑧ lights while the RPT/OPT is active, and goes out while inactive.

3. Repeater Setup/Knockdown ⑥

The setup button is a momentary contact switch that enables or disables the main radio of TR-800.

4. LCD Display ⑦

Display current channel number, frequency, power level, receive status, etc.

5. Power Switch/Volume Control Knob ⑨

The power switch is located in the center of the knob, short press of which turns repeater on, and long press for 1 second turns repeater off. Rotate the volume control knob clockwise or counter-clockwise to adjust the volume for a desired level.

6. Microphone Hook ⑩

7. RPT Button, OPT Button

Press the RPT button ⑫ to enable uni-directional repeater, and press the OPT button ⑪ to enable bi-directional repeater.

8. Scan Button, Monitor Button

Press the Scan button ⑬ to initiate repeater scan, which can be activated only when in

uni-directional mode (forward directional, i.e., RPT is active while OPT is inactive).

Short press the Monitor button ⑰ to display channel frequency by turns of slave radio Rx frequency, slave radio Tx frequency, main radio Rx frequency, main radio Tx frequency; long press it to monitor the activities on the current channel. The main radio processes monitoring while OPT is active, the slave radio processes monitoring while OPT is inactive.

9. “Up” Button ⑮, “Down” Button ⑬

Press the “Up” or “Down” button to select a desired channel.

10. RJ45 Connector ⑭

Plug the desktop microphone or palm microphone into this port to input audio, or plug the programming cable into this port to program both radios.

11. Antenna Connector

The N connector ⑲ is for connecting with the main radio’s antenna, while the BNC connector ⑱ is for the slave radio’s antenna.

When using duplexer, choose the correct adaptor on the back of TR-800 according to your antenna connector type.

12. Fan ⑳

The fan is temperature-controlled with continuously variable speed as temperature changes.

13. AC Power Inlet ㉑ (with Switch ㉒)

14. Accessory Connector ㉓ (DB15/F)

Used for external controller or link equipment.

15. Grounding Lug ㉔

For lightning protection, this terminal must be connected to an absolute earth ground via thick copper wire, or use lightning arrester if necessary.

16. DC Power Inlet ㉕

The power supply would auto-revert to backup battery once the AC mains fails. This DC port also provides floating charge function with approximate 400mA current.

17. DC Fuse ㉖

The 15A/32Vdc fuse protects against battery polarity reversal.

■ **Software Specification**

Basic Operation

Short press the power switch to turn on the repeater; rotate the volume control knob clockwise to adjust the volume for a comfortable listening level. Press the “Up” or “Down” button to select a desired channel, then the repeater operates as you set.

1. To achieve the basic repeater functions, the radio must be in the repeater setup, and operates in the uni-directional or bi-directional repeater mode.

Repeater Hang Time

When the repeater stops receiving upon signal off, the transmitter remains transmitting for a programmed time period, which reduces delay on conversation due to the setup of repeater link. The repeater Hang Time can be activated when in forward directional repeater only.

Frequency Display

Short press the Monitor button displays the frequency in the turn of: slave radio Rx frequency, slave radio Tx frequency, main radio Rx frequency, main radio Tx frequency.

Monitor

If the Monitor function is set by your dealer, long press the programmed Monitor key while in receive mode, to hear activities on current channel. The monitor function is disabled while in the bi-directional repeater mode. Four operation modes listed below are provided for you to choose via the programming software.

A. Carrier Squelch-Momentary

Hold down the Monitor key to open CTCSS/CDCSS/DTMF/2-Tone/5-Tone signalling squelch. Release it to close the signalling squelch.

B. Carrier Squelch-Toggle

Press the Monitor key to open CTCSS/CDCSS/DTMF/2-Tone/5-Tone signalling squelch. Press it again to close the signalling squelch.

C. Squelch Off-Momentary

Hold down the Monitor key to open carrier squelch; release it to close the carrier squelch.

D. Squelch Off-Toggle

Long press the Monitor key to open carrier squelch. Press it again to close the carrier squelch.

Scan

The Scan function can be activated while in the forward directional repeater mode only. Press the Scan

button to initiate repeater scan (if scan parameter is applicable). The Scan Interval Time and Dropout Delay Time are configurable via the programming software.

Signalling Squelch

This feature can be enabled/disabled by your dealer. If the feature is enabled, the preset DTMF/2-Tone /5-Tone will control repeater mute/unmute. The repeater will not unmute until valid signalling is received.

CTCSS/CDCSS

Set up talkgroups/users with unique CTCSS/CDCSS to prevent unwanted conversations on the same frequency. If CTCSS/CDCSS is set on current channel, a CTCSS/CDCSS match will be required on an incoming call. If not set, the radio unmutes to all calls within the communication range on current channel. Your dealer may preset CTCSS/CDCSS on certain channels.

Note: This feature does not mean that your conversation will not be heard by others.

Time-out Timer (TOT)

The feature allows for efficient use of channels by limiting the maximum time of each transmission. It protects the radio from damage caused by long time transmission. Once a continuous transmission exceeds the preset time (15~1200s programmable), the transmission will be automatically terminated and alert tone will be heard. The alert tone ceases upon the release of the PTT.

Selectable Squelch Level (SQL)

Squelch levels from 0 to 9 are selectable via the programming software.

Voice Compander/Scrambler

The voice compander/scrambler feature may be enabled/disabled via the programming software. The emphasis/de-emphasis function needs to be disabled while the scrambler feature is enabled, and enabled while the scrambler feature is disabled.

High/Mid/Low Power Programmable

High/Med/Low power is selectable via the programming software.

Programmable Channel Spacing

A wide/narrow channel spacing is selectable via the programming software.

Repeater Modes

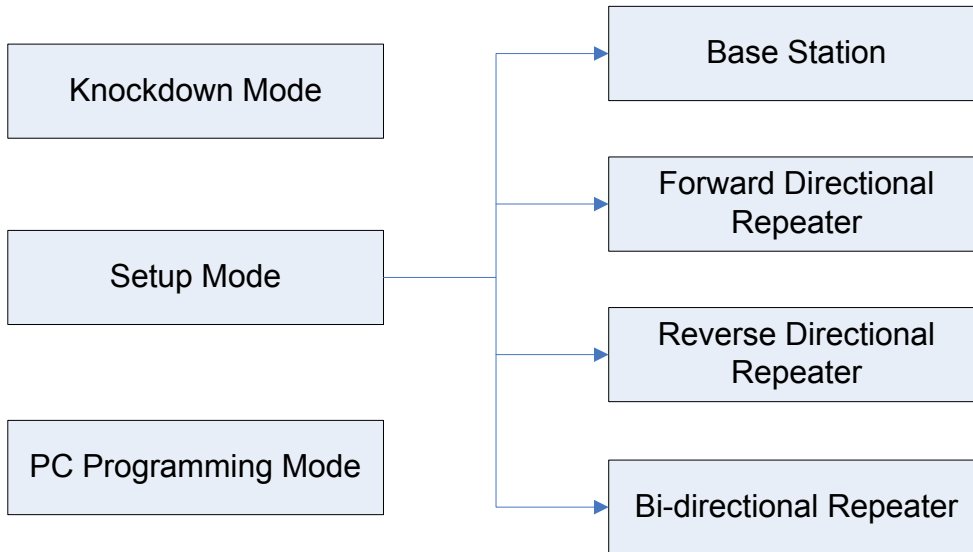

Modes Description

Mode		Description
Knockdown		Press the SETUP button while the repeater is power on. The repeater enters knockdown mode once the orange LED goes out.
Setup	Base Station	Press RPT and OPT buttons when the SETUP orange LED is on. The radio enters base station mode once both the RPT and OPT blue LEDs go out.
	Forward Directional Repeater	Press RPT and OPT buttons when SETUP orange LED is on. The repeater enters forward directional mode once the RPT blue LED is on while the OPT blue LED goes out.
	Reverse Directional Repeater	Press RPT and OPT buttons when the SETUP orange LED is on. The repeater enters reverse directional mode once the RPT blue LED goes out while the OPT blue LED is on.
	Bi-directional Repeater	Press RPT and OPT buttons when the SETUP orange LED is on. The repeater enters bi-directional repeater mode once both the RPT and OPT blue LEDs is on.
PC Programming		The repeater enters PC programming mode once command is received from PC, while the SETUP orange LED is on.

Repeater Setup/Knockdown

Press the SETUP button located on the front panel to toggle between repeater setup and knockdown, with LED indications. While in setup state, both radios turn on at power up; in knockdown state, only receive radio turns on at power up. There are three repeater types: base station, uni-directional and bi-directional in the repeater setup state. The repeater is initialized to base station mode when it toggles from knockdown to setup state. But in the knockdown state, the repeater works only as a receiver.

In base station mode, the repeater function is disabled, with the slave radio as a receiver and the main radio as a transmitter. In bi-directional repeater mode, the front panel PTT is disabled.

The repeater setup/knockdown status will be recorded after the repeater power failure. (E.g. If the repeater operates in forward directional mode, it will still work in such mode after the power recovers)

PC Programming Mode





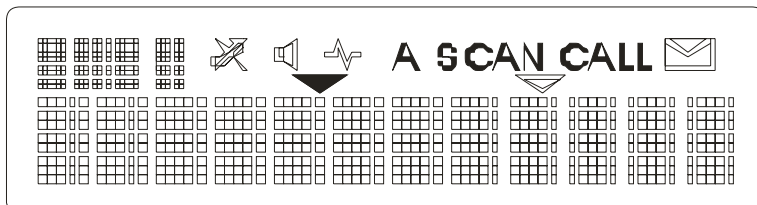

Connect the PC with the repeater via programming cable. Data can be transmitted from PC to the repeater. Repeater LCD displays “PROGRAMMING” while reading/writing data from/into the radio, with red LED flashes indicating programming the main radio, and then green LED flashes indicating programming the slave radio. The repeater **resets** automatically after programming is finished.

LCD Display



LCD Icon Description

Indicator	Description
	<ol style="list-style-type: none"> 1. Displays zone/channel number 2. Displays zone/channel name up to 12 alphanumeric characters (preprogrammed by your dealer) 3. Displays channel frequency 4. Displays preprogrammed function
	<ol style="list-style-type: none"> 1. Displays zone/channel number 2. Displays transmit power level (the 4th digit: H, M, L) 3. Displays preprogrammed function

	Appears when the current channel is already in use
	Appears when the Monitor key is pressed to disable CTCSS/DCS, DTMF, 2-Tone/5-Tone decoding.
	Appears when the repeater is unmuted upon the monitor key is pressed.
A	Indicates the feature development feature.
SCAN	Appears while repeater scanning.
CALL	Appears when transmitting a selective call.
	Appears when a message is received.
	Reserved
	Reserved

LED Indicator

LEDs indicate real-time radio status shown as the following table:

LED	Description	Indicates:
Tx	Red	<ol style="list-style-type: none"> 1. Lights while the main radio is transmitting. 2. Flashes while the main radio is receiving. 3. Flashes while the main radio is monitoring channel activities. 4. Flashes while programming the main radio.
Rx	Green	<ol style="list-style-type: none"> 1. Lights while the slave radio is transmitting. 2. Flashes while the slave radio is receiving. 3. Flashes while the slave radio is monitoring channel activities. 4. Flashes while programming the slave radio.
RPT	Blue, ultra bright	<ol style="list-style-type: none"> 1. Lights while the RPT is active. 2. Goes out while the RPT is inactive.

OPT	Blue, ultra bright	<ol style="list-style-type: none">1. Lights while the OPT is active.2. Goes out while the OPT is inactive.
SETUP	Orange	<ol style="list-style-type: none">1. Lights while in the Setup state.2. Goes out while in the Knockdown state.
BAT	Dark red	<ol style="list-style-type: none">1. Lights while the backup battery supplies power.2. Goes out while the AC mains supplies power.

■ **Circuit Description**

Repeater Communication Interface & Display Unit

Theory of Operation

Setup/Knockdown (U0107D, Q0101, Q0103, Q0106, Q0107 and Q0108):

The Setup/Knockdown state at power-up can be configured via HR-800 programming software. The electronic switch, Q0106 and Q0108, causes the Setup/Knockdown action by applying or removing voltage at the ignition control, pin15, of "J0102-Main". After power-up, the Setup or Knockdown state may be changed remotely with a signal from pin10 of "J4-Slave" or locally through the front panel SETUP. S0102 is a momentary contact switch that is debounced by the Q0103/Q0107 latch circuit. The orange "SETUP" LED, CR0102, illuminates to indicate the Setup state.

As the Setup/Knockdown circuit goes from the Knockdown to the Set-up state, Q1 is momentarily turned on by Q0108 via the C0101/R0103 timing circuit. The push to talk (PTT) input of the slave radio, pin8 of "J4-Slave" is pulled low by Q0101 and keys the transmitter. The "Rx" LED, CR0105, will briefly flash during the moment that Q0101 is conducting.

Forward Audio Routing (U0103A, U0104A, U0104D and U0105A):

The audio gate, U0104D, quarter of an analog switch BU4066B, enables and disables the audio from front panel MIC audio input. U0104D is turned on with an active dc level high driven at the output of NAND gate U0103A-3 by the front panel PTT input. The slave radio audio output from pin5 of "J0104-Slave" is routed to a potentiometer, RV0101. The output of RV0101 is applied to another switch U0104A. U0104A is enabled once a valid signal is received and will route the audio to transmitter. The external audio input, ACC Relay audio, is routed to another potentiometer, RV0103. The output of RV0103 is applied to the second half of U0105, an operational amplifier NJM2904. U0105A, R1106 and R0118 make a buffer amplifier for the link audio. All the "forward" audio will mix together and route through S0101-5 to the main microphone transmitter audio, pin2 of "J0106-Main".

Reverse Audio Routing (U0104B and U0104C):

Part of front panel MIC audio is routed to the input of U0104B, quarter of the analog switch BU4066B. The output of U0104B is also controlled with an active low input by the front panel PTT. Audio present on pin5 of "J0102-Main" is routed through S0102-7 to a potentiometer, RV0102, which is used to adjust the audio level for proper deviation. As with the forward direction, the audio output of RV0102 is applied to an analog switch U0106A. This switch turns on only if a valid signal is detected and pin6 of U0104 goes high.

Forward and Reverse Key-up (Q0102, U0103, U0107, Q0105, Q0111 and Q0116):

When a valid input signal is present at the slave radio, pin6 of "J0104-Slave" will be pulled low and turn off Q0105 through two NAND gates, U0107B and U0107C, along with RPT enable trigger. A dc level high output from Q0105 will be applied to pin37 of U0110 and keys the main radio PTT through output from pin12. The red "Tx" LED, CR0106, illuminates.

When the reverse key-up function is enabled, as in the bi-directional repeater configuration, S0101-8 must be on. Q0116 is a dc amplifier (buffer) for the Rx Carrier signal from pin6 of "J0102-Main". An active

low state at the input of the NAND gate U0107A, one quarter of a MC14011B, will be converted to a high state to drive the buffer for the Rx Carrier signal. The active low level of Rx Carrier signal, along with the OPT enable signal, cause a series of NAND gates, U0103D, U0103C and U0103B to generate a high dc level to turn on Q0102. The output of Q0102 is pulled low for pin8 of “J0104-Slave” and keys the transmitter of slave radio. The green “Rx” LED, CR0105, illuminates.

Q0111 is used to prevent the simultaneous active state on PTT and Rx Carrier signal of “J0102-Main”, which possibly causes unwanted tie condition of keying of both radios.

Accessory D-SUB 15pin receptacle (“J0103-Acc”)

The accessory D-Sub, “J0103-ACC”, is connected to “J0102-Main” and “J0104-Slave” to supply Rx audio and PTT for linked radios (repeaters) or external controllers. Receive audio and PTT activation from the linked facilities are applied to the repeater for transmission.

Display Unit (U0110, PB01-PB06, K02, Q0113 and Q0118)

All the functional triggers of enable and disable come from keypad PB01 to PB06. K02 is an encoder switch for front speaker audio output adjustment. A high output from pin37 of CPU U0110 will turn Q0119 on, driving the base of Q0118 to go low. The backlight LED for the keypad, CR0107, CR0108, CR0111-CR0114 illuminate. Another backlight driver, Q0113, is controlled by Q0114 through the output from pin17 of U0110.

Peripheral Circuitry (U0108, U0109, KR00 and KR03)

Operating power bus for all the electronics originates from the switch power 13.8Vdc output, pin9 of “J0107-Slave”, and goes through U0109 and U0108 to obtain the reference voltages of 9Vdc and 5Vdc. KR00 is a DPDT relay driven by transistor Q0123. The output from pin25 of U0110 will turn on/off Q0123, which activates relay KR00 to toggle the front speaker audio routes from slave radio or from main radio. KR03 is another SPDT relay for audio test requirement. A dc level high output from pin26 of U0110 will turn on Q0124 and keys relay KR03. The receive audio to the speaker is blocked and routes only to pin8 of the front RJ45 connector J0109.

IMPORTANT NOTE

Using CTCSS or CDCSS tones may have a lower probability to open squelch than carrier operation. But the CTCSS codes near 100Hz and 150Hz have a high false opening probability due to 50Hz AC power harmonics. Countries having 60Hz AC power may have false opening on 120Hz and 180Hz. CTCSS code 254.1Hz has a high probability of squelch tails.

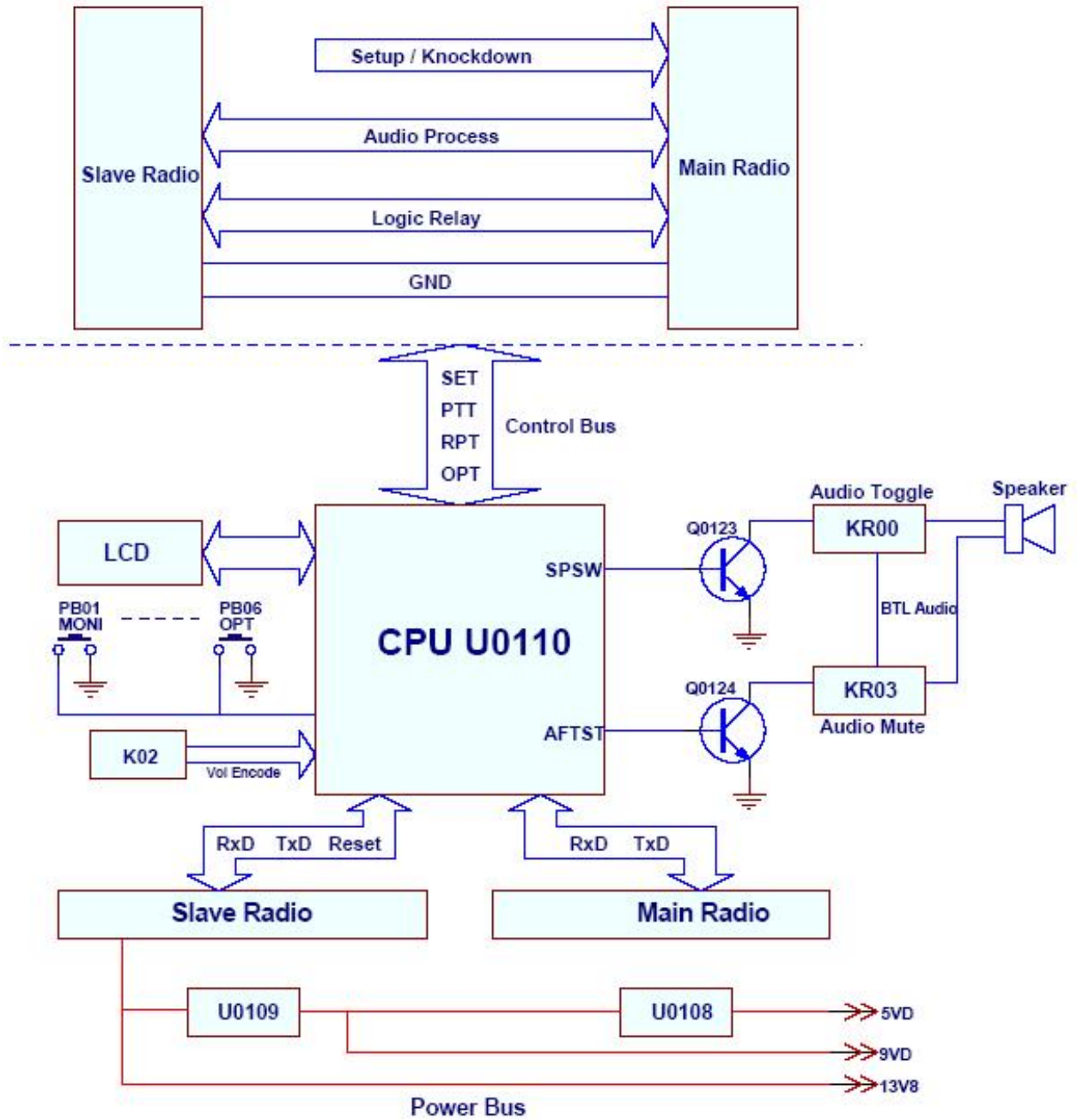

Figure I Block Diagram

Power Management

Theory of Operation

Battery Revert Circuit:

A voltage reference network consisting of CR0212, CR0213, R0268, and VR0209 provides a stable voltage reference of 7.5Vdc. This reference voltage, at the anode of VR0209, is applied to the negative input of the Over Voltage Detector U0206B-6, to the positive input of AC Fail Detector U0206A-3, and to the positive input of the Low Battery Detector U0205B-5. Operating positive supply voltage for the integrated circuits is obtained from the TR-800 power supply through CR0212 when the TR-800 is operating on AC mains input power. The supply voltage is obtained through CR02013 when the station is operating on the battery.

During normal operation under AC mains power, the negative input of the AC Fail Detector U0206A-2 is more positive than the positive input U0206A-3. The output of U0206A-1 is low and Q0224, the driver for relay KR01, and Q0216, the "BATTERY ON" driver, are turned off. When AC mains power is lost, the voltage at U0206A-2 becomes lower than the reference voltage applied to U0206A-3. The output at U0206A-1 then goes high and turns on both Q0224, which activates relay KR01 and transistor Q0216, which provides a low at the output point "BATTERY ON". The "BAT ON" LED, CR0219, illuminates to indicate the DC power supply is operating.

If the battery voltage falls below approximately 10.2Vdc, the output at U0205B-7 will go high. This action turns on Q0218 that shunts the base drive to Q0224 through CR0217 and turns off the relay. Q0218 also provides a low through CR0218 at output point "BAT LOW". This auxiliary output might be used to key a portable radio to signal the repeater operator that the battery has exceeded the low voltage limit for the radios. Hysteresis is provided by the feedback network consisting of CR0221, R0289 and R0288 from the output of U0205B-7 to the positive input U0205B-5. The reference voltage at the positive input of U0205B-5 is increased such that the battery voltage must rise above 12Vdc before relay KR01 will reactivate and place the TR-800 back on battery power. This latching action is used to prevent excessively deep discharging of the battery.

The repeater will remain turned off until either AC mains return or a charged battery is substituted for the discharged battery. The circuit consisting of C0233, R0285, R0286, CR0220, R0287 and Q0217 resets U0205B-7 to low upon the return of the AC mains power.

Capacitor C0234 at the negative input of U0205B-6 smoothes the variation in the battery voltage between the transmit radio keyed and unkeyed conditions. Capacitor C0230 at U0206A-2 input, in conjunction with C0234 at U0205B-6, ensures proper resetting of U0205B with the return of the AC mains power.

The Over Voltage Detector consisting of U0206B and resistors R0274, R0275 and R0271 monitors the DC output of the TR-800 power supply. If the voltage exceeds 16.4Vdc, the output of U0206B-7 goes high and turns on relay driver Q0224. The station switches to battery power although there is no indication at the "BAT ON" output point.

Zener diodes VR0210, VR0211, VR0212, VR0215 and VR0216 protect the electronics from damage by accidental static discharge.

Fuse F0203-15A and diode and CR0215 provide protection from reverse polarity if the battery is inadvertently connected "backward".

Variable speed, Temperature controlled Fan Circuit:

The TL431AILP is a three-terminal programmable shunt regulator diode. This monolithic IC voltage reference operates as a low temperature coefficient zener that is programmed from 6Vdc to 12Vdc with a resistor network consisting of R0296, R0297 and an NTC thermistor Rth0201. Q0219 operates as a fast power switch between “ON” and “OFF” (similar to PWM mode) controlled by the output at cathode of TL431AILP. The rotating speed of brushless fan is voltage controlled at collector of Q0219. The higher temperature, the higher power supply to the fan, hence the faster it rotates.

Battery charging (Float Maintenance) Circuit:

The battery charging circuit is intended for use with sealed lead acid gel cell batteries. The charging current, limited to approximately 400mA, is used to maintain a “float” charging condition on the battery. After operating the TR-800 station on the battery for long periods of time, or if the battery reaches the low battery limit of the revert circuit, the battery must be recharged with an external high-current charger. Recharging with the internal trickle charger requires an extended period of time.

The trickle charging voltage is derived from AC mains. Resistors R0269 limit the charging current to approximately 400mA to a partially discharged battery (terminal voltage of 12Vdc). Once the battery is fully charged, the current will decrease to 10 to 25mA to float the battery at a terminal voltage of 13.6Vdc.

NOTE

This trickle charger is intended to maintain the battery for long periods of time between power failures and is not intended for charging a fully discharged battery. If the battery is completely discharged, it must be removed and charged via a battery charger with higher current capability.

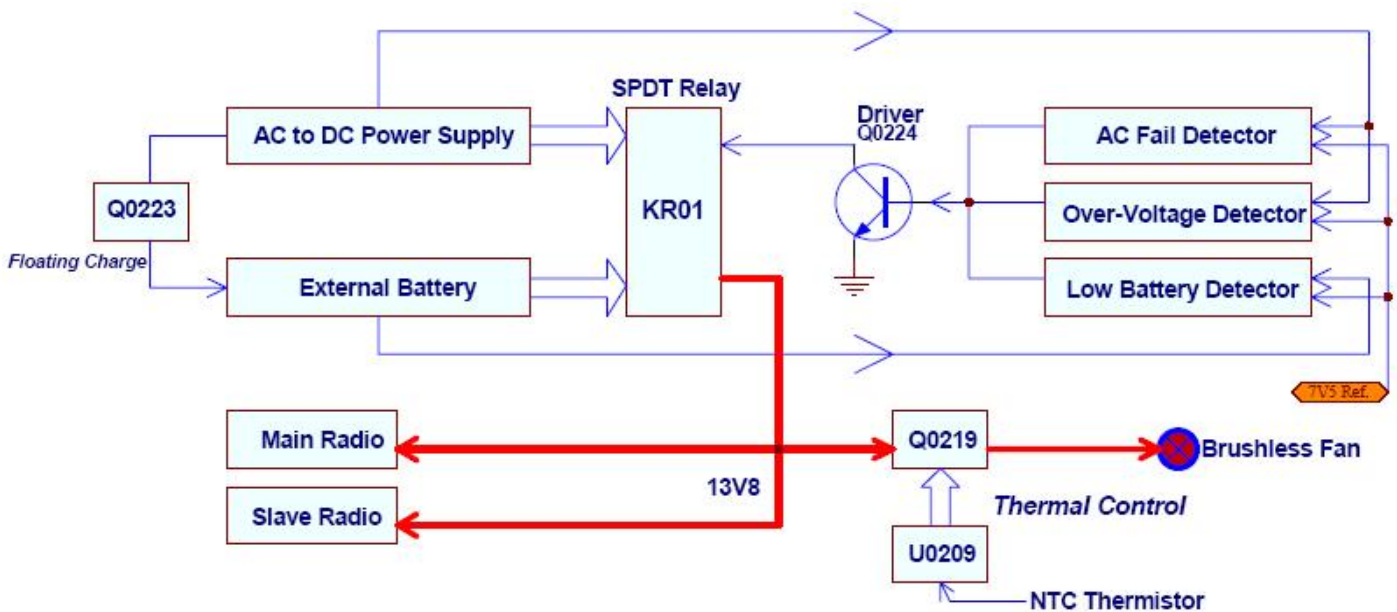

Figure II Block Diagram

Glossary

Bi-directional Repeater:

A repeater configuration in which the main and slave radios perform both receive and transmit functions. The audio and Rx Carrier signals from the receiver of the slave radio are routed to the transmitter of the main radio. Unlike the unidirectional case, though, the audio and Rx Carrier signals of the receiver of the main radio are also routed to the transmitter of the slave radio.

Cross band repeater:

A repeater in which the slave radio operates in a different frequency band than the main radio. Example: the slave radio operates on 162.075MHz in the high band VHF and the main radio operates on 452.025MHz in the 450-470MHz UHF band. Cross-band repeaters may be either unidirectional or bi-directional.

Main Radio:

The radio that performs the transmitting functions in the TR800 repeater station in the general unidirectional application.

Relay Delay Time:

The time duration the repeater remains in transmit mode after an active or valid signal is no longer detected.

Repeater Knockdown:

To deactivate a repeater or to remove it from service. Only the slave radio turns on at power up.

Repeater Setup:

To activate a repeater or to place it into service. Both radios turn on at power-up (repeater functional).

Single band repeater:

A repeater in which both the slave radio operates in a same frequency band. Example: receive at 455.075MHz and transmit at 460.075MHz in the 450-470MHz UHF band.

Slave Radio:

The radio that performs the receiving functions in the TR800 repeater station in the general unidirectional application.

Unidirectional Repeater:

A repeater configuration in which the slave radio receives signals only from the field radios and the main radio transmits signals only to the field radios.

■ MPU Pins

Repeater front panel

(MPU Model: uPD780114, CRYSTAL: 9.8304MHz)

PIN No.	PIN NAME	I/O	DESCRIPTION
1	AVref	I	Connect VDD
2	AVss	I	To GND
3	IC(V _{PP})	I	To GND (programming pin) short-circuit resistor added
4	V _{DD}	I	+5V
5	V _{ss}	I	GND
6	X1	I	Clock Input
7	X2	O	Clock output
8	RESET	I	Knockdown
9	XT1	I	NC Connect VDD
10	XT2	I	NC Open
11	SHIFT	O	Clock Frequency Shift Active: H
12	PTT/O	O	Main radio PTT signal output control Active: L
13	RxD2	I	Analog serial data input (slave MPU communication)
14	TxD2	O	Analog serial data output (slave MPU communication)
15	RSW0(DN)	I	Encoder knob [DOWN] button input High/low level
16	RSW1(UP)	I	Encoder knob [UP] button input Rising Edge / Falling Edge active
17	LCDBL/LED0	O	LCD backlight control/LED0 Active: H
18	LCDCS/LED1	O	LCD chip selection output/LED1
19	LCDSOD/LED2	I/O	LCD data reading/LED2 (LCD/LED I/O)
20	LCDDAT/LED3	O	LCD data output/LED3
21	LCDCCLK/LED4	O	LCD clock output/LED4
22	EV _{ss}	I	GND
23	E V _{DD}	I	Connect VDD (programming pin)
24	AFTest	O	Audio test control
25	SpkSW	O	Main/slave speaker output control H: Main unit outputs L: slave radio outputs
26	RXD1	I	Serial data input (main MPU communication)
27	TXD1	O	Serial data output (main MPU communication)
28	SETUP/O	O	Repeater setup output Active: H
29	HOOK/RXD0	I	Palm microphone HOOK input/serial data input Active: L
30	TXD0	O	Serial data output PTT active: L
31	RLED	O	Red LED Active: H
32	GLED	O	Green LED Active: H
33	PTT	I	Palm microphone PTT key input PTT Active: L
34	OPT/O	O	OPT signal output Active: H

35	RPT/O	O	RPT signal output	Active: H
36	KEYBL	O	Keypad backlight control	Active: H
37	Rx Tone/I	I	Slave radio signal input	Active: L ()
38	SETUP/I	I	SETUP signal input	On: H (rising edge trigger)
39	OPT/I	I	OPT key input	Active: L ()
40	RPT/I	I	RPT key input	Active: L ()
41	DN	I	DN key input	Active: L ()
42	UP	I	UP key input	Active: L ()
43	SCAN	I	SCAN key input	Active: L ()
44	MONI	I	MONI key input	Active: L (external pull-up resistor connected)

■ TR-800 Part List (Logic board)

No.	P/N	Part Description	Ref. No.	Address	Qty.	Remark
1	3001060000000	Chip resistor 0603 0Ω J 1/10W	R0158	B3B	15	
			R0164	B2E		
			R0170	B4C		
			R0176	B4C		
			R0178	B4B		
			R0181	B4B		
			R0182	B4B		
			R0183	B4B		
			R0184	B4B		
			R0185	B3B		
			R0186	B3B		
			R0199	B2B		
			R1101	B4C		
			R1103	B3B		
			R1113	B4F		
2	3001061020010	Chip resistor 0603 1KΩ J 1/10W	R0148	B3C	10	
			R0149	B3C		
			R0163	B3A		
			R0172	B3C		
			R0173	B3C		
			R0174	B3C		
			R0175	B3C		
			R0179	B4B		
R0180	B4B					
R0195	B1C					
3	3001061030010	Chip resistor 0603 10KΩ J 1/10W	R0103	B2G	12	
			R0104	B3E		
			R0115	B3E		
			R0117	B3E		
			R0130	B3F		
			R0140	B3E		
			R0141	B3E		
			R0143	B2E		
			R0146	B1B		
			R0147	B1B		
R0171	B3B					

			R1121	B2D	
4	3001061040010	Chip resistor 0603 100KΩ J 1/10W	R0118	B3F	4
			R0145	B1B	
			R0198	B4E	
			R1106	B2D	
5	3001061220000	Chip resistor 0603 1.2KΩ J 1/10W	R0125	B2E	1
6	3001061510000	Chip resistor 0603 150Ω J 1/10W	R0168	B2A	1
7	3001061520000	Chip resistor 0603 1.5KΩ J 1/10W	R0127	B3F	1
8	3001061540010	Chip resistor 0603 150KΩ D 1/10W	R1115	B2D	1
9	3001062230000	Chip resistor 0603 22KΩ J 1/10W	R0139	B2F	2
			R0121	B3E	
10	3001062240010	Chip resistor 0603 220KΩ J 1/10W	R0197	B4E	1
11	3001062720000	Chip resistor 0603 2.7KΩ J 1/10W	R0107	B3G	3
			R0126	B3G	
			R0128	B3F	
12	3001062730000	Chip resistor 0603 27KΩ D 1/10W	R0166	B3A	1
13	3001064710000	Chip resistor 0603 470Ω J 1/10W	R0129	B2F	1
14	3001064720000	Chip resistor 0603 4.7KΩ J 1/10W	R0105	B3E	7
			R0124	B2D	
			R0142	B2E	
			R0159	B3B	
			R0177	B4C	
			R1114	B4C	
			R1118	B4B	
15	3001064730000	Chip resistor 0603 47KΩ J 1/10W	R0101	B3G	25
			R0102	B2G	
			R0106	B3G	
			R0108	B2E	
			R0109	B3G	
			R0110	B3G	
			R0111	B3G	
			R0112	B3F	
			R0150	B3C	
			R0151	B3C	
			R0152	B3C	
			R0153	B3C	
			R0154	B3C	
			R0155	B3C	
			R0156	B3E	
			R0160	B3B	
			R0161	B4E	
			R0162	B4E	
			R0187	B3B	

			R0188	B3B	
			R0189	B3B	
			R0190	B3B	
			R1105	B3B	
			R1111	B4B	
			R1112	B3B	
16	3001065620010	Chip resistor 0603 5.6KΩ J 1/10W	R0138	B2F	2
			R0157	B2C	
17	3001065630000	Chip resistor 0603 56KΩ J 1/10W	R1109	B2D	1
18	3001066800000	Chip resistor 0603 68Ω J 1/10W	R0167	B3A	1
19	3001066820000	Chip resistor 0603 6.8KΩ J 1/10W	R1104	B3B	1
20	3001066830000	Chip resistor 0603 68KΩ J 1/10W	R1110	B3D	1
21	3001162290000	Chip resistor 2010 2.2Ω J 1/2W	R0193	B4E	2
			R0194	B4D	
22	3001162700000	Chip resistor 2010 27Ω J 1/2W	R0165	B4A	1
23	3002994720010	Trimmer resistor 2.7*2.0*1.6 4.7KΩ ±25%	RV0104	B3A	1
24	3009161510000	Chip thick-film resistor 2010 150Ω F 3/4W	R0169	B4C	1
25	3101061010010	Chip capacitor 0603 100PF J 50V	C0163	B4F	5
			C0164	B4F	
			C0165	B4F	
			C0168	B4F	
			C0171	B3F	
26	3101062200010	Chip capacitor 0603 22PF J 50V	C0131	B2B	2
			C0132	B2B	
27	3101066800000	Chip capacitor 0603 68PF J 50V	C0133	B3B	1
28	3101071020010	Chip capacitor 0805 1000PF K 50V	C0150	B1C	12
			C0151	B1B	
			C0152	B4D	
			C0154	B1C	
			C0155	B1C	
			C0156	B5E	
			C0157	B5E	
			C0162	B4F	
			C0166	B4F	
			C0169	B5F	
			C0170	B5F	
			C0175	B1C	
29	3101071030010	Chip capacitor 0805 0.01UF K 25V	C0124	B2E	8
			C0130	B2B	
			C0134	B3B	
			C0135	B4E	
			C0136	B4E	
			C0143	B2B	

			C0149	B1B	
			C0161	B4E	
30	3101073340000	Chip capacitor 0805 0.33UF K 16V	C0110	B2E	7
			C0111	B3E	
			C0117	B2E	
			C0118	B2F	
			C0120	B3E	
			C0121	B2E	
			C0172	B2D	
31	3101074710010	Chip capacitor 0805 470PF K 50V	C0103	B3E	14
			C0112	B2E	
			C0123	B4E	
			C0126	B3A	
			C0129	B2B	
			C0137	B3A	
			C0138	B3A	
			C0139	B3B	
			C0140	B2A	
			C0142	B2B	
			C0144	B4B	
			C0145	B2D	
			C0146	B3D	
			C0148	B1B	
32	3104081060070	Ta-capacitor 1206 10UF M 16V	C0102	B3E	5
			C0104	B3E	
			C0105	B3E	
			C0147	B1C	
			C0160	B4F	
33	3104081560020	Ta-capacitor 1206 15UF M 10V	C0127	B1B	2
			C0128	B2A	
34	3213212102010	Multi-layer inductor 1008 1uH	L0101	B4F	2
			L0102	B4F	
35	3221506601000	Chip ferrite bead 0603 600Ω±25%	L0103	B2B	3
			L0105	B2B	
			L0106	B4F	
36	3301240700000	Schottky diode MBD301	CR0101	B3G	1
37	3302030500020	Zener diode UDZSTE(1718B)18V	VR0108	B4F	1
38	3302240000040	Zener diode BZX84C5V1	VR0101	B2F	7
			VR0102	B3E	
			VR0103	B2E	
			VR0104	B3G	

			VR0105	B4E	
			VR0106	B2E	
			VR0107	B2F	
39	3307110100090	LED KPT-1608CGCK Green	CR0107	T4F	6
			CR0108	T3F	
			CR0111	T4F	
			CR0112	T2F	
			CR0113	T2D	
			CR0114	T3D	
40	3399010600000	Switching Diode HSB123TR-E	D0112	B4B	8
			D0113	B4B	
			D0114	B3B	
			D0115	B4B	
			D0116	B3B	
			D0117	B4B	
			D0118	B2B	
			D0119	B3B	
41	3403002000000	Transistor 2SB1132L02T100R	Q0118	B4C	1
42	3403008000010	Transistor DTC114EE(TL)	Q0102	B3E	9
			Q0105	B2E	
			Q0111	B2E	
			Q0114	B2D	
			Q0115	B3A	
			Q0117	B2A	
			Q0119	B3B	
			Q0120	B2D	
			Q0121	B3D	
43	3410001000040	Transistor 2SA1641(S.T)	Q0113	B3A	1
44	3414001000020	Transistor MMBT3906	Q0101	B3G	2
			Q0106	B3F	
45	3414001000030	Darlington Transistor MMBTA13	Q0116	B2E	1
46	3414001000040	Transistor MMBT3904	Q0103	B3G	5
			Q0107	B3G	
			Q0108	B3F	
			Q0123	B4C	
			Q0124	B5B	
47	3503020000030	FET 2SK1824-T1-A	Q0112	B3B	1
48	3605008001690	Operational amplifier NJM2904M	U0102	B3E	2
			U0105	B2F	
49	3607037000000	Logic IC(NAND)-MC14011	U0103	B4E	2
			U0107	B2E	
50	3608002020890	Power management IC TA7805F(TE16L.F) 5V	U0108	B2A	1
51	3609018001090	IC BU4066BCFV Quad analog switch IC	U0104	B3E	1

52	3610003000000	SCM UPD78F0114HGB-8ES	U0110	B3B	1
53	3701098340020	Crystal 9.8304MHz NX8045GB SMD	X01	B3B	1
54	4002000000070	Fuse 0466.200.NR 0.2A/125V	F0101	B5F	1
55	5202008100020	Chip socket 52746-0870 8pin	J0110	T3A	1
56	5202011100010	Chip socket B11B-ZR-SM3-TF(LF)	J0106	B1C	2
			J0107	B5D	
57	410R800100030	TR-800 Logic board PCB FR4 1.6T/2L/2P			1
58	3001063310010	Chip resistor 0603 330Ω J 1/10W	R0191	B2D	2
			R0192	B3D	
59	3303040400010	Switch diode BAS16	CR0103	B2F	1
60	3104081060080	Ta-capacitor 1206 10UF M 10V	C0141	B2B	1
61	3002995020000	Ceramic alloy potentiometer 5KΩ K CT-94EW	RV0101	B2D	2
			RV0102	B3E	
62	3002995030020	Ceramic alloy potentiometer 50KΩ K CT-94EW	RV0103	B2D	1
63	3101991050000	Polyester capacitor 4.5*13.5*10 1uF J 63V	C0101	B3G	1
64	3301200200000	Rectifier diode 1N4004 DO-41	CR0104	B3F	1
65	3307110600010	LED L-483GDT Green 2.5*5mm 2.2V	CR0105	T2A	1
66	3307110600020	LED L-483IDT Red 2.5*5mm 2.0V	CR0106	T2A	1
67	3307110600030	LED L-483YDT Yellow 2.5*5mm 2.1V	CR0102	T4A	1
68	3307110600050	LED L-483EDT Orange 2.5*5mm 2.0V	CR0119	T3A	1
69	3307990000080	LED LT5CB4-81-XA400714 super bright blue	CR0109	T2D	2
			CR0110	T3D	
70	3614037000000	3-Terminal voltage regulator IC MC78M09	U0109	B1B	1
71	4301060000010	Toggle switch SSGM1A0100	S01	B2G	1
72	4301080000040	Momentary contact switch (SPEA122200)	S02	T4A	1
73	4302030000040	Channel switch RH90N74AE20	K02	T4D	1
74	5110000000190	LCD Module JIC-MSBF-8943-06 (red backlight)		T3B	1
75	5202002100100	Pin socket 89400-0220 2pin	J0111	B1C	2
			J0113	B4C	
76	5202015200000	HDB15/F socket (DIP) 5512-15SA-01-BRJ-F1	J0102	B1E	3
			J0103	B2C	
			J0104	B1D	
77	5202040100030	Dual-row pins 40pin	J0113	B4E	0.1
78	5204008000000	RJ45 socket MODS-A-8P8C-H-S 8-line SHIELDED	J0109	B5G	1
79	7000037000000	Heat sink 15.3*17mm	U0109	B1B	1
80	7103008001010	Machine screw M3.0*8.0mm pan-head (Nickel-plating)	U0109	B1B	1
81	4308990000000	Low signal Relay G5V-1 9V DC	KR03	B5C	1
82	4308990000060	Low signal relay G5V-2-DPDT 12VDC 2A	KR00	B4C	1

TR-800 Part List 1 (Power Management Board)

No.	P/N	Part Description	Ref. No.	Address	Qty.	Remark
1	3001061000000	Chip resistor 0603 10Ω J 1/10W	R2103	T2E	1	
2	3001061020010	Chip resistor 0603 1KΩ J 1/10W	R0285	T2B	2	
			R2101	T2D		
3	3001061030010	Chip resistor 0603 10KΩ J 1/10W	R0278	T2B	4	
			R0284	T2A		
			R0287	T3B		
			R2100	T2B		
4	3001061040010	Chip resistor 0603 100KΩ J 1/10W	R0274	T1A	3	
			R0281	T2A		
			R0289	T3B		
5	3001062720000	Chip resistor 0603 2.7KΩ J 1/10W	R0299	T3A	1	
6	3001061530010	Chip resistor 0603 15KΩ J 1/10W	R0280	T1B	2	
			R0292	T2F		
7	3001062220000	Chip resistor 0603 2.2KΩ J 1/10W	R0294	T2D	1	
8	3001062230000	Chip resistor 0603 22KΩ J 1/10W	R0271	T1A	4	
			R0286	T2B		
			R0290	T3B		
			R0291	T3A		
9	3001062430010	Chip resistor 0603 24KΩ J 1/10W	R0275	T1A	1	
10	3001063330010	Chip resistor 0603 33KΩ J 1/10W RCT03333J	R0279	T1B	2	
			R0293	T2E		
11	3001064710000	Chip resistor 0603 470Ω J 1/10W	R0267	T2F	2	
			R0268	T2E		
12	3001064720000	Chip resistor 0603 4.7KΩ J 1/10W	R0272	T1A	7	
			R0273	T2A		
			R0282	T2A		
			R0288	T3B		
			R0295	T2D		
			R2102	T2D		
			R2104	T2E		
13	3001066830000	Chip resistor 0603 68KΩ J 1/10W	R0296	T3E	1	
14	3001069130000	Chip resistor 0603 91KΩ D 1/10W	R0297	T3E	1	
15	3001081020000	Chip resistor 1206 1KΩ J 1/4W	R0270	T1B	1	
16	3101071030010	Chip capacitor 0805 0.01UF K 25V	C0239	T3E	1	
17	3101071040000	Chip capacitor 0805 0.1UF K 25V	C0226	T2B	3	

			C0233	T2A	
			C0240	T2D	
18	3101074710010	Chip capacitor 0805 470PF K 50V	C0227	T2B	8
			C0228	T1B	
			C0229	T2B	
			C0231	T1A	
			C0235	T2A	
			C0236	T3A	
			C0237	T3A	
			C0238	T3A	
19	3101081050020	Chip capacitor 1206 1UF K 25V	C0242	T2D	1
20	3414001000040	Transistor 300MHz 0.3V	Q0126	T2A	4
			Q0218	T3B	
			Q0220	T2D	
			Q0224	T1A	
21	3414001000020	Transistor PNP-SOT23-250MHz-0.3V	Q0217	T3B	2
			Q0222	T1B	
22	3605008001690	Operational amplifier NJM2904M DUAL	U0205	T3B	2
			U0206	T1A	
23		Switch diode BAS16	CR0212	T3D	7
	3303040400010		CR0213	T2F	
			CR0216	T2A	
			CR0217	T2B	
			CR0218	T3B	
			CR0220	T2B	
			CR221	T2B	
24	3413001000000	Transistor UFM718 PNP SOT23	Q0223	T1B	1
25	3104082250030	Ta-capacitor 1206 2.2UF K 16V	C0234	T3B	1
26	3302240000050	Zener diode BZX84C27	VR0208	T3D	10
			VR0209	T2E	
			VR0210	T1B	
			VR0211	T1A	
			VR0212	T2E	
			VR0213	T2A	
			VR0214	T2A	
			VR0215	T3F	
			VR0217	T1B	
27	4011000000010	SMD fuse SMD 200F-2 15V 2A	F0202	T2B	1
28	410R800200100	TR-800 power supply board PCB FR4 1.6T/2L/4P			1
29	3302240000030	Zener diode-BZX84C7V5	VR0209	T2E	2
			VR0218	T2A	
30	3003991040010	Thermistor sensor 100KΩ ±1% NTC	Rth0201	B3D	1
31	3099990228000	Leaded resistor 0.22Ω J 2W	R0269	B3C	1

32	3103991060020	Electrolytic capacitor 4*7 10UF ±20% 25V	C0230	B2B	1
33	3103991070090	Electrolytic capacitor 6*12 100UF ±20% 25V	C0225	B2D	2
			C0232	B2D	
34	3103992280020	Electrolytic capacitor 12.5*25 2200uF ±20% 25V	C0241	B2D	1
35	3103994770030	Electrolytic capacitor 2512 470UF 25V M 105°C	C0243	B3E	1
36	3216599224000	Bobbin inductor 0.35mm 220uH PI-DRU002-0031	L0201	B2E	1
37	3301160200000	Rectifier diode 1N5401D	CR0224	B3E	1
38	3301200200000	Rectifier diode 1N4004 DO-41	CR0214	B1B	2
			CR0223	B1B	
39	3301200200010	Rectifier diode 1N5821_rlg	CR0222	B2E	1
40	3301240400000	Three-terminal regulator diode TL431	U0209	B2D	1
41	3004116050000	Varistor 2512 6MΩ 0-0.05%/°C	CR0215	B1F	1
42	3416002000010	Transistor TIP42C PNP	Q0219	B1E	1
43	4002000000040	ATO Fuse clip 100057 15A	F0203	B2F	1
44	4210080000700	Speaker connection cable (2Pin plug) 2-core 80mm	Rth0201	B3D	1
45	4200250000000	TR-920 DC power cable#14 250mm	CN0201	B3D	1
46	4200250000100	TR-920DC power cable#14 250mm	CN0201	B3D	1
47	4200400000010	Connection cable 2PIN 450MM UL1007 #26	CR0219	B3A	1
48	4200400000200	Power cable L400MM 2PIN UL1015 #14	CN0202	B1D	1
49	4200250000200	Power cable L250MM 2PIN UL1015 #14	CN0203	B1D	1
50	4308990000010	Power relay G8P-1C4P-SPDT 12VDC 20A	KR01	B2C	1
51	5202002100100	Pin socket 89400-0220 2pin	Rth0201	B3D	1
52	5202002100000	Socket 3750S-02 2pin	CONN1	B3F	1
53	5202040100030	Dual-row pin 40pin	BAT LOW	B2B	0.05
54	5204002000000	DC power socket L150MM UL1015 #14	CN0204	B1F	1
55	7000037000000	Heat sink 15.3*17mm	Q0219	B1E	1
56	7103008001010	Machine screw M3.0*8.0mm Pan-head	Q0219	B1E	1

■ Adjustment Description

Logic Board Adjustment

Test Apparatus

- | | |
|---|------|
| 1. 20A/30V Power Supply | 1set |
| 2. Ammeter | 1set |
| 3. Digital Voltmeter | 1set |
| 4. Test Jumper Cables (mating with test ports of TR-800 and the communication test set) | |
| 5. Communication System Analyzer (such as HP8921 series) | 1set |

Adjustment

Radio Configuration

Use HR-800E to program the TR-800. Table I and table II illustrate the factory default settings in a general operation mode. The "Ignition Sense Time" of main radio defines time delay from SETUP to KNOCKDOWN.

Table I Radio Programming Preset

Item	Main Radio	Slave Radio
AUX3 I/O	Ext. PTT	Ext. PTT
AUX4 I/O	Rx Carrier(Tone)	Rx Carrier(Tone)
AUX5 I/O	Rx Tone(Carrier)	Rx Tone(Carrier)
Horn Alert Logic	NA	1s
Ignition Sense	0h0m	NA
Drop Out Delay	3s	
Scan Gap Time	400ms	
Repeater Hang Time	2s	

Table II Logic Board Switch Configuration:

Toggle Switch	S01-1	S01-2	S01-3	S01-4	S01-5	S01-6	S01-7	S01-8	S01-9	S01-10
Factory Default	ON	OFF	OFF	ON	ON	ON	ON	ON	OFF	ON

Test Procedure

a) Base Station Mode

Make sure the TR-800 is in SETUP state and deactivate RPT & OPT functions. The TR-800 operates on base station mode with main radio to transmit and slave radio to receive (similar to a mobile radio). Correctly cable the test ports to communication system analyzer before adjustment.

Item	Condition	Measure		Adjustment		Specification/Remark
		Instrument	Point	Point	Method	
Slave radio receive	Channels with/without	Communication test set	J0109	K02	Rotate the knob to adjust the volume	Squelch open sensitivity: -118±3dBm

	tones				to rated power, check receiver's squelch open/off sensitivity, with signaling squelch open sensitivity, audio distortion & Rx S/N	Squelch off sensitivity: -118±3dBm CCTSS squelch sensitivity: -118±3dBm CDCSS squelch sensitivity: -118±3dBm Audio distortion: ≤3%@3W ≤10%@5W Rx S/N: ≥45dB (wide) ≥40dB (narrow)
Main radio transmit	Any channel without tones	Communication test set	Main radio Tx connector	/	Adjust the MIC audio output amplitude of Analyzer to 6-10mV into J0109 3pin; check Tx frequency deviation matching 60% system Dev.; check modulation distortion and Tx S/N	Tx frequency deviation: 3.0±0.2kHz (wide) 1.5±0.1kHz (narrow) Modulation distortion: ≤3% Tx S/N: ≥45dB (wide) ≥40dB (narrow)

b) Uni-directional Repeater Mode (Forward)

Make sure the TR-800 is in SETUP state and activate RPT function. The TR-800 operates on uni-directional repeater mode with slave radio keys main radio to repeat transmission (forward direction). Correctly cable the test ports to communication system analyzer before adjustment.

Item	Condition	Measure		Adjustment		Specification/Remark
		Instrument	Point	Point	Method	
MONI	Any channel	/	/	MONI	Check up	Long press monitor key, the slave radio processes monitoring, with green LED flashes
Uni-directional repeater (forward)	Channels with/without tones	Communication test set	Main radio Tx connector	RV0101	Adjust the signal output amplitude of Analyzer to -47dBm, adjust RV0101 to obtain a 60% system deviation; check the modulation distortion and RX S/N; decrease the signal output	Duplex sensitivity: -116(+1/-3dBm) CTCSS sensitivity: -116(+1/-3dBm) CDCSS sensitivity: -116(+1/-3dBm) Repeater frequency deviation: 2.9±0.2kHz (wide) 1.4±0.1kHz (narrow) Repeater audio distortion: ≤3%@3W

					amplitude of the analyzer, check the duplex sensitivity.	$\leq 10\% @ 5W$ Tx S/N: $\geq 42dB$ (wide) $\geq 37dB$ (narrow) Max. Power output (without duplexer): $45 \pm 2W$ (UHF) $50 \pm 2W$ (VHF)
Rx audio output	Any channel without tones	Communication test set	J0103	/	Check the audio output amplitude of 5 pin on the accessory connector	Audio output: $\geq 200mV$
Repeater Hang Time	Any channel	Communication test set	/	/	In the repeater setup state, terminate the signal output of the analyzer, check the repeater hang time.	Repeater hang time: 2S
Linked audio relay	Any channel without tones	Communication test set	Main radio Tx connector	RV0103	Adjust the audio output amplitude of the analyzer MIC to 120mV into 3 pin of J0103; adjust RV0103 to obtain a 60% system deviation, check modulation distortion and TX S/N	Tx frequency deviation: $3.0 \pm 0.2kHz$ (wide) $1.5 \pm 0.1kHz$ (narrow) Modulation distortion: $\leq 3\%$ Tx S/N: $\geq 45dB$ (wide) $\geq 40dB$ (narrow)
Repeater Scan	Any channel	Signal generation or radio	/	/	Set SCAN key active	Use signal generator or portable transmitter to test whether repeater scanning works correctly and processes retransmission, and repeat testing on other channels.

c) Uni-directional Repeater Mode (reverse)

Make sure the TR-800 is in SETUP state and activate OPT function. The TR-800 operates on uni-directional repeater mode with slave radio keys main radio to repeat transmission (backward direction). Correctly cable the test ports to communication system analyzer before adjustment.

Item	Condition	Measure		Adjustment		Specification/Remark
		Instrument	Point	Point	Method	

MONI	Any channel	/	/	MONI	Check up	Long press the monitor key, the main radio processes monitoring, with red LED flashes.
Slave radio transmit	Any channel without tones	Communication test set	Slave radio Rx connector	/	Adjust the audio output amplitude of the analyzer MIC to 7mV into 3 pin of J0109, check the TX frequency dev. Matching of 60% system Dev., check modulation distortion and TX S/N.	duplex frequency deviation: 3.0±0.2kHz (wide) 1.5±0.1kHz (narrow) Modulation distortion: ≤3% Tx S/N: ≥ 45dB (wide) ≥40dB (narrow)
Uni-directional repeater (reverse)	Channels with/without tones	Communication test set	Slave radio Rx connector	RV0102	Adjust the signal output amplitude of Analyzer to -47dBm, adjust RV0102 to obtain a frequency dev. of 60%; check the modulation distortion and TX S/N; decrease the signal output amplitude, check the duplex sensitivity.	Duplex sensitivity: -117(+1/-3dBm) CTCSS duplex sensitivity: -117(+1/-3dBm) CDCSS duplex sensitivity: -117(+1/-3dBm) Repeater frequency deviation: 2.9±0.2kHz (wide) 1.4±0.1kHz (narrow) Repeater audio distortion: ≤3%@3W ≤10%@5W Tx S/N: ≥42dB (wide) ≥37dB (narrow) Max. Power output (without duplexer): 45±2W(UHF) 50±2W(VHF)

d) Radio Kill Function

Item	Condition	Measure		Adjustment		Specification/Remark
		Instrument	Point	Point	Method	
Remote Knockdown	Channel with optional signaling	Radio	/	/	Set S01-2 "ON"	Transmit DTMF code via the portable radio to remotely disable the main radio, orange LED goes out and the TR-800 is in knockdown state

e) Knockdown State

Item	Condition	Measure		Adjustment		Specification/Remark
		Instrument	Point	Point	Method	
Knockdown state	Any channel with SETUP disabled	Handheld microphone or test cable	/	MONI, SCAN pushbutton	/	Short or long press of the monitor and scan button is disabled; unable to transmit with palm microphone or test cable connected, only receives (i.e. only slave radio works and receive only)

f) Provisory Settings

At the end of the test, set S01-2, S01-3, S01-9 to "OFF" to prohibit users the access to **the D.B.D feature**, only your dealer or skilled technicians are authorized to enable this feature upon the requirement of users.

Power Management Board Adjustment

Test Apparatus

- | | |
|--|------|
| 1、 20A/30V Power Supply | 1set |
| 2、 Analog ammeter | 1set |
| 3、 Digital Voltmeter | 1set |
| 4、 12V lead acid battery (not fully charged) | 1set |

Circuit detect and temperature-control test

Connect CN0201 (To Power Supply) and CN0204 (To Ext. Battery) with DC power output 13.8V respectively.

Item	Condition	Measure		Adjustment		Specification/Remark
		Instrument	Point	Point	Method	
AC to DC over-voltage detect	/	Digital voltmeter	CR0219	CN0201	Increase or decrease the input voltage	Gradually increase the voltage of CN0201 to 16.4V, the protection circuit will drive KR01 to revert to DC power supply. Decrease the voltage of CN0201 to 13.4V and return to AC power supply.
AC mains fail detect	/	/	CR0219	CN0201	Close or open input voltage	Remove the voltage of CN0201, driving KR01 to revert to DC power supply with CR0219 illuminates; Apply voltage to CN0201, and KR01 is activated, then return to AC power supply with CR0219 goes out.
Battery low detect	Close CN0201 voltage	Digital voltmeter	CR0219 ,BAT LOW	CN0204	Raise or lower input voltage	Gradually decrease the voltage of CN0204 to 10.2V, driving KR01 to cut down DC power supply, with CR0219 goes out, "BAT LOW" provides a low; Apply voltage to CN0201, with CR0219 flashes briefly, then return to AC power supply; remove the voltage of CN0201, gradually increase the voltage of CN0204 to 12V, the KR01 is activated to toggle to DC power supply with CR0219 illuminates.
Thermal controlled fan	Soldering iron or hot air gun	Digital voltmeter	Fan	Rth0201	Heating or cooling	Heat the Rth0201 with soldering iron or hot air gun, check the voltage of fan increases (6.0V~11.5V) with the air flow increases.

Floating charge test

Connect CN0204 to 12V battery; CN0201 remains connected with 13.8V power supply.

Item	Condition	Measure		Adjustment		Specification/Remark
		Instrument	Point	Point	Method	
Floating charge	/	Analog Ammeter	CN0204	/	Check	Check the charging current is about 400mA, and will drop to 10-25mA when fully charged.

Duplexer Instructions

Electrically a duplexer is a device using sharply tuned resonate circuits to isolate a transmitter from a receiver. This allows both of them to operate on the same antenna at the same time without the transmitter RF frying the receiver. Before using your repeater, you must tune the duplexer using one of the following three methods for ensuring that the duplexer is tuned to the correct frequencies of operation:

◆ **Pre-Tuned Method (preferred method)**

Order the duplexer from the manufacturer or supplier pre-tuned to the desired frequencies. This is not a “method” of tuning the duplexer but does not require any field tuning or test equipment. Note that there must be a separation of the transmit and receive frequencies. This is called “split”. On two meters the split is about 600 KHz. On 70cm the split is much easier to do 5MHz.

◆ **Visual Method**

Use a tracking (sweep) generator and spectrum analyzer to adjust the tuning of the pass bands and reject bands of the duplexer.

◆ **Emergency Method**

The following paragraphs address a simple method of tuning a “notched” duplexer such as DT04 UHF duplexer. This is not as accurate a method of tuning as the visual method afforded by the tracking generator /spectrum analyzer sweep setup but it is much less costly. It may be sufficiently good for all but the most exacting applications.

Use this method only when the operating frequencies of the main radio and slave radio meet the requirements of the duplexer. The duplexer you can order from HYT is notched type (band-reject) only and the minimum separation available is 4MHz on UHF band and 3.5MHz on VHF band. Note that this notched type duplexer offers a considerably narrow bandwidth. If the operating transmitter/receiver frequencies for the TR-800 are appreciably different than that of duplexer specification, degraded performance of the repeater will result.

The following procedure assumes that the duplexer is applied and the radios should be connected to the proper ports of the duplexer with the RF coaxial cables provided in the TR-800 kit. The duplexer should not be mounted on the bracket and the tuning screws of the duplexer (on the other side of the cavities, opposite to the RF connectors) should be accessible.

Programming the Radios

1. Program the main radio with an additional “receive only” mode at the frequency of receive (assume that the main radio operates as transmitter of a uni-directional repeater).
2. Program the slave radio with an additional “receive only” mode at the frequency of transmit (assume that the slave radio operates as receiver of a uni-directional repeater).
3. Connect a communications test set, such as HP8921 series, or an RF signal generator to the antenna port of the duplexer. The test set should be operating in the “Generate” mode. Modulate the RF source with a 1kHz tone at 60% system deviation to facilitate “hearing” the signal during the tune-up procedure.

Tuning the Main Radio Section

Tuning the main radio section of the duplexer begins with the tuning screw closest to the antenna port of the duplexer.

1. Adjust the frequency of the communication test set or generator to that of receive.
2. Place the main radio on the receive frequency mode defined in Step 1 under "Programming the Radios".
3. Adjust the level of the communication test set or generator until the main radio emits a weak signal.
4. Increase the level of the communication test set or generator by approximately 20dB.
5. Adjust the tuning screw of the duplexer for the greatest rejection of the signal. This will appear as a noisier signal. **If necessary:**
 - 5A. Slightly loosen the locking nuts of the tuning screws to allow the tuning screws to turn more freely (but not "sloppy") **and**
 - 5B. Increase the level of the communication test set or generator to maintain an audible 1kHz tone.
6. Repeat steps Step 4, Step 5, Step 5A and Step 5B for each of the tuning screws on the duplexer. Begin with the tuning screw closest to the antenna port and move in order toward the tuning screw closest to the main radio port.
7. Tighten the locking nuts of the tuning screws.

To avoid damage to the tuning screws and to allow fine tuning of the duplexer, do not over tighten the locking nuts.
8. Repeat Step 5, Step 5A and Step 5B to fine-tune the main radio section of the duplexer.

Tuning the Slave Radio Section

Tuning the slave radio section of the duplexer begins with the tuning screw closest to the antenna port of the duplexer.

9. Adjust the frequency of the communication test set or generator to that of transmit.
10. Place the slave radio on the receive frequency mode defined in Step 2 under "Programming the Radios".
11. Adjust the level of the communication test set or generator until the slave radio emits a weak signal.
12. Increase the level of the communication test set or generator by approximately 20dB.
13. Adjust the tuning screw of the duplexer for the greatest rejection of the signal. This will appear as a noisier signal. **If necessary:**
 - 13A. Slightly loosen the locking nuts of the tuning screws to allow the tuning screws to turn more freely (but not "sloppy") **and**
 - 13B. Increase the level of the communication test set or generator to maintain an audible 1kHz tone.
14. Repeat steps Step 12, Step 13, Step 13A and Step 13B for each of the tuning screws on the duplexer. Begin with the tuning screw closest to the antenna port and move in order toward the tuning screw closest to the slave radio port.
15. Tighten the locking nuts of the tuning screws.

To avoid damage to the tuning screws and to allow fine tuning of the duplexer, do not over tighten the locking nuts.
16. Repeat Step 13, Step 13A and Step 13B to fine-tune the slave radio section of the duplexer.

■ Disassembly and Installation

Removing and Installing the Top Cover

1. using a screwdriver to Remove the seven screws (M3.0X6.0) ① that locking the top cover of repeater, shown as Figure 1.
2. Remove the top cover ②, shown as Figure 1.
3. Install the top cover as reverse steps.

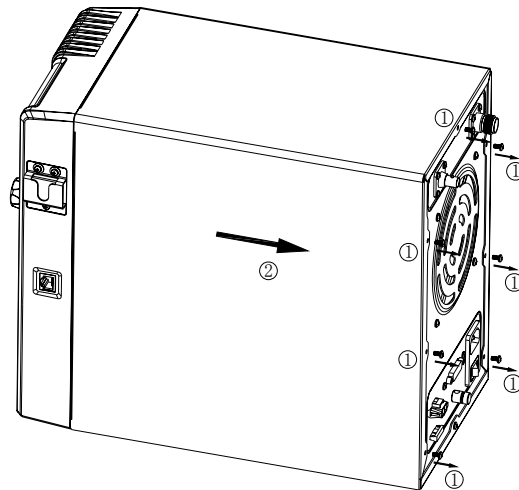

Figure 1

Removing and Installing the Front Panel

1. Press the 6 latches that locking the front panel to the housing to separate and remove them from the housing ①, shown as Figure 2.
2. Remove the front panel ② shown as Figure 2, and pull out the two set of jumper wires, two repeater cables, accessory connector cable, and connecting cable of the DC power indication LED.
3. Install the front panel as reverse steps.

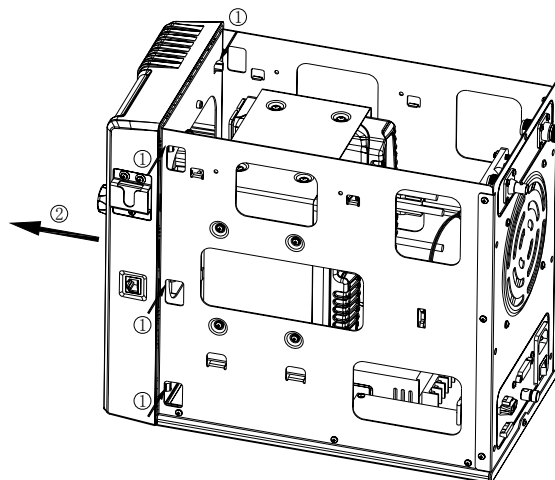

Figure 2

Removing and Installing the Control Panel

1. Remove the Volume Control knob ① shown as Figure 3.
2. Remove the nut ② using a special spanner, shown as Figure 3.
3. Remove the six screws (ST3.0X8.0) ③ that secure the control panel using a screwdriver, shown as Figure 4.
4. Gently press and remove the RJ45 port ④ from the front panel, then pull out the speaker cable to remove the controller PCB, shown as Figure 4.
5. Install the control panel as reverse steps.

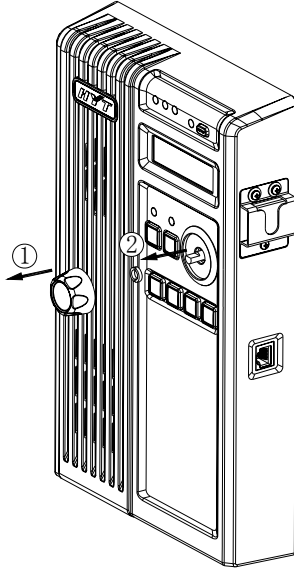

Figure 3

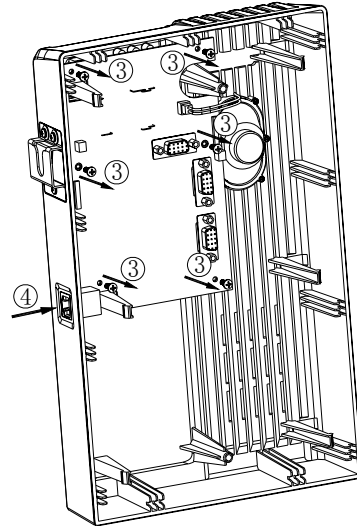

Figure 4

Removing and Installing the Rear Plate

1. Pull out the ATO fuse ①, shown as Figure 5.
2. Press the spring latch ② located on the two edges of the DC socket, and push the DC socket into the housing to separate the socket from the rear plate ③, shown as Figure 5.
3. Remove the seven screws (M3.0X6.0) ④ that secure the rear plate using a screwdriver, shown as Figure 5.
4. Remove the two RF cables of both radios, and connecting cable of the fan, then remove the 3 power jumper cables that connecting AC socket with switch power, using a screwdriver, and that's all for you to get prepared to remove the rear plate.
5. Installing the rear plate as the reverse steps.

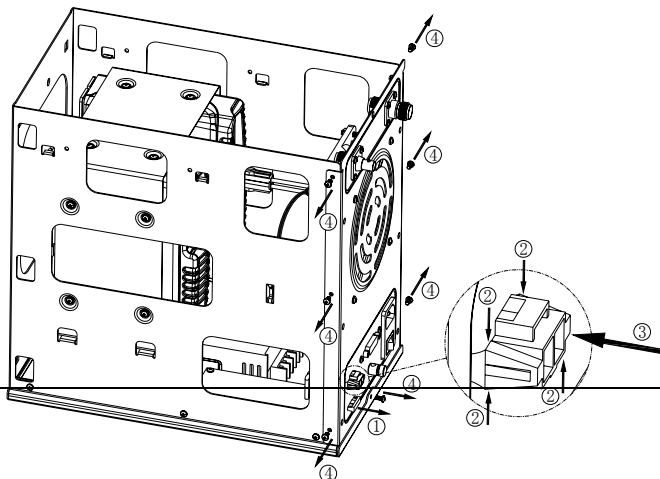

Figure 5

Removing and Installing the Radio

1. Remove the screw (M4.0X6.0) ① that secure the thermistor sensor using a screwdriver, shown as Figure 6.
2. Remove the eight screws (M3.0X6.0) ② that secure the bracket of radio using a screwdriver, shown as Figure 6.
3. Remove the bracket ③ shown as Figure 6, and remove the 2 signal cables and 2 power cables of both radios.
4. Remove the eight screws (M4.0X6.0) ④ that secure both radios using a screwdriver, and then remove both radios ⑤, shown as Figure 7.
5. Install both radios as the reverse steps.

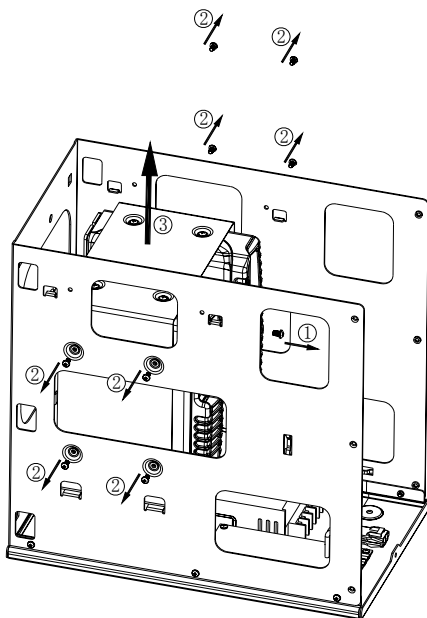

Figure 6

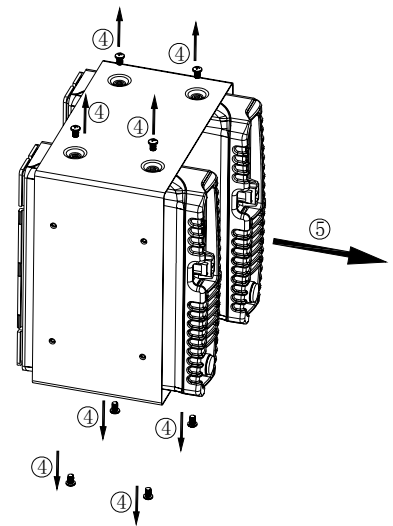

Figure 7

Removing and Installing Housing

1. Remove the six screws (M3.0X6.0) that secure the housing using a screwdriver, to remove the housing ①, shown as Figure 8.
2. Install the housing as the reverse steps.

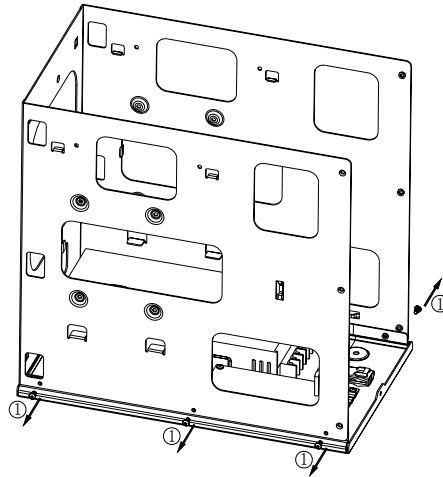

Figure 8

Removing and Installing Switch Power

1. Remove the four screws (M4.0X6.0) that secure the switch power using a screwdriver, to remove the switch power ①, shown as Figure 9.
2. Install the switch power as the reverse steps.

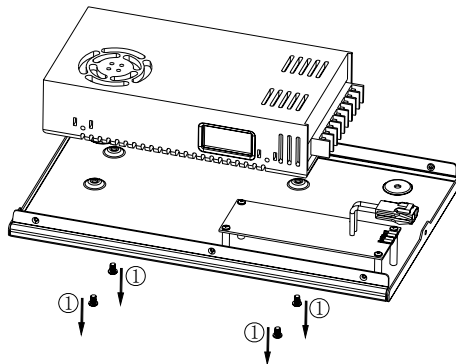

Figure 9

Removing and Installing the Power Management PCB

1. Remove the four screws (M3.0X6.0) that secure the power management PCB using a screwdriver, to remove the power management PCB ①, shown as Figure 10.
2. Install the power management PCB as the reverse steps.

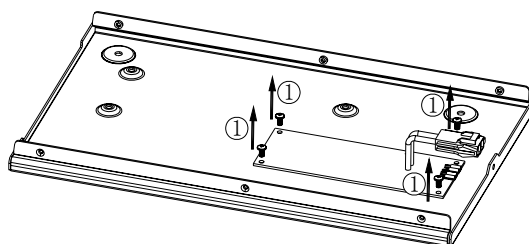
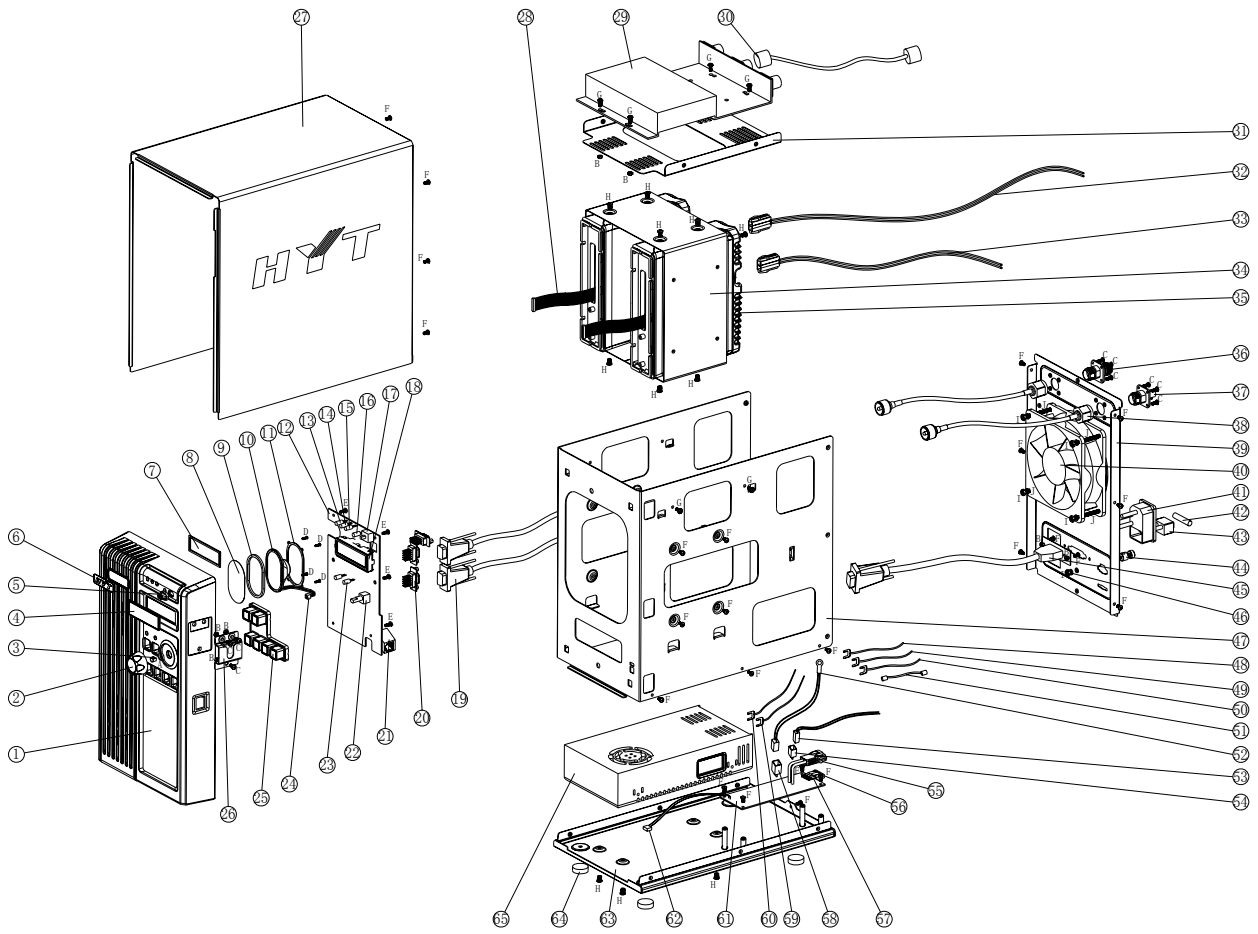

Figure 10

■ Exploded View



■ TR-800 Parts List 2

No.	Material No.	Material Name	Qty.
A	7207002200000	Nut M7.0*2.2mm	1
B	7203002400000	Nut M3.0*2.4mm	9
C	7103008001010	Machine screw M3.0*8.0mm	13
D	7102007020000	Self-tapping screw ST2.0*7.0mm	4
E	7103008020000	Self-tapping screw ST3.0*8.0mm	6
F	7103006001000	Machine screw M3.0*6.0mm	34
G	7103008001020	Machine screw M3.0*8.0mm	8
H	7104006000000	Machine screw M4.0*6.0mm	13
I	7204003001000	Nut M4.0*3.0mm	5
J	7104045000000	Machine screw M4.0*45.0mm	4
1	6000220000000	Front panel	1
2	6000221000000	Volume control Knob	1
3	6201066000000	Inner liner knob 0.20mm	1
4	6000232000010	LCD lens	1
5	6000222000000	SETUP button	1
6	5403000000040	HYT LOGO aluminum	1
7	7500068000000	LCD sponge	1
8	7400048010000	grill cloth 58*35mm	1
9	6100182000000	speaker	1
10	5001020000000	Speaker 16Ω 7W D: 35mm	1
11	6201176000000	speaker tableting	1
12	1302008000000	control board	1
13	3307110600020	LED L-483IDT red	1
14	3307110600010	LED L-483GDT green	1
15	3307110600050	LED L-483EDT orange	1
16	3307110600030	LED L-483YDT yellow	1
17	4301080000040	Momentary contact switch	1
18	5110000000110	LCD Module TM-800	1
19	4210400000100	repeater cable	2
20	5202015200000	HDB15/F socket (DIP)	3
21	5204008000000	RJ45 socket	1
22	4302030000040	Channel selector	1
23	3307990000080	LED LT5CB4-81-XA400714 ultra bright blue	2
24	4210080000700	Connecting cable of speaker (with 2 Pin plug) 2-core	2
25	6100135000000	silica rubber key	1
26	6201197000000	SM07 Hook	1
27	6201166000000	top cover	1
28	4200200000000	jumper cable	2

29	Optional	Duplexer	1
30	4220300000200	RF cable	1
31	6201171000000	duplexer bracket	1
32	4200400000200	power cable	1
33	4200250000200	power cable	1
34	6201170000000	bracket 0.8mmSECC	1
35	Optional	main radio (Slave radio)	2
36	4408100002000	RF adaptor	1
37	4408100003000	RF adaptor	1
38	4220250000100	RF cable	2
39	6201168000000	rear plate	1
40	5401000000050	DC fan 12Vdc 0.9A	1
41	5205000000240	AC socket L46.80*W27.40mm 3pin	1
42	4099000000150	Cartridge fuse	1
43	4399010000000	Power switch	1
44	7104008000000	GND lug	1
45	4210400000200	T expansion signal cable	1
46	6201192000000	spring lock washer	5
47	6201169000000	housing	1
48	4210250000000	DC jumper cable #14 250mm red	1
49	4210250000100	DC jumper cable #14 250mm black	1
50	4210250000200	DC jumper cable #14 250mm yellow	1
51	4210250000300	DC jumper cable #14 250mm green	1
52	3003991040010	Surface temperature sensor	1
53	4200050000000	power cable of fan (2 pin with plug) 50mm	1
54	5202002100000	Socket 2pin	1
55	5204002000000	DC power socket	1
56	4002000000030	ATO Fuse	2
57	4002000000040	ATO Fuse clamper	2
58	5202002100100	Pin socket	3
59	4200250000000	DC power cable #14 250mm red	1
60	4200250000100	DC power cable #14 250mm black	1
61	1302008000010	Power supply board	1
62	4200400000010	Connection cable	1
63	6201167000000	Base tray	1
64	7500147000100	Foot	4
65	1603S24000010	Switch power	1

■ Packing

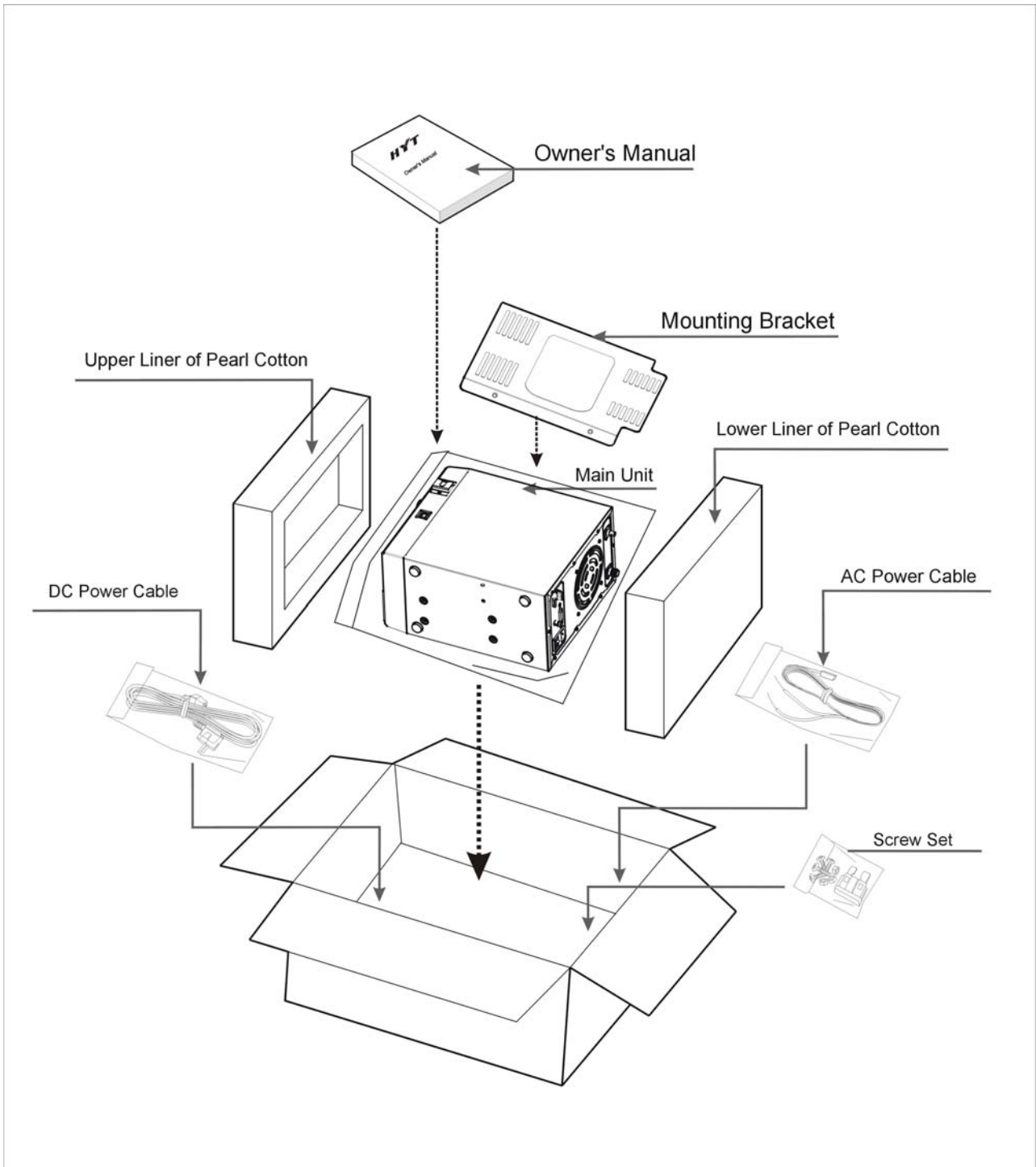

■ Specifications

General	
Frequency range (Unit: MHz)	VHF:136MHz~174MHz;U5:350MHz~400MHz U1: 400MHz~470MHz; U2: 450MHz~512MHz
Channel capacity	512
Channel spacing	25KHz / 12.5KHz
Power supply requirement	13.8 V DC±20% / 88-264V AC 50/60Hz
Duty cycle	25W(100% Continuous) / 50W(VHF)45W(UHF)(50% Intermittent)
Power consumption	<1.8A Standby <2.5A Receive <13A @ 50/45W Transmit (13.8V dc)
Operating temperature range	-25°C ~ +60°C
Dimensions	190mm (W) × 310mm (H) × 362mm (D)
Weight	11kg
Receiver	
Sensitivity	<0.35uV@12dB SINAD
Adjacent channel selectivity	≥70dB(Wide) ≥60dB(Narrow)
Intermodulation response rejection	≥70dB
Spurious response rejection	≥75dB
Rated Audio Output Power	5W(Int.) 12W(Ext. @ 4Ω)
Rated Audio Distortion	≤3% (3W) ≤10% (5W)
Frequency stability	±2ppm@ -25°C ~ +60°C
Transmitter	
Carrier output power (Conducted)	25W / 50W(VHF) 45W(UHF)
Spurious emission	≤ -36dBm (below 1GHz)
Max. Frequency deviation	5KHz(Wide) / 2.5KHz(Narrow)
FM Hum and Noise	≥45dB(Wide) ≥40dB(Narrow)
Audio harmonic distortion	≤3% @ 60% Dev.
Frequency stability	±2ppm@ -25°C ~ +60°C

All Specifications are subject to change without notice due to continuous development.