



Catalog Number 8544

# **Sigma 900 Composite Sampler**

INSTRUMENT MANUAL



<b>Section 1 Specifications</b> .....	5
<b>Section 2 General Information</b> .....	7
2.1 Instrument Description.....	7
2.2 Interface Connectors.....	7
2.2.1 Receptacle Caps.....	7
2.3 Front Panel.....	8
2.3.1 Keypad and Display.....	8
2.3.2 Humidity Indicator.....	8
2.4 Safety Information.....	9
2.4.1 Use of Hazard Information.....	10
2.4.2 Precautionary Labels.....	10
2.4.3 Hazardous Locations.....	10
2.4.4 Confined Space Entry.....	11
2.4.5 Definition of Confined Space.....	12
<b>Section 3 Installation</b> .....	13
3.1 Unpacking the Instrument.....	13
3.2 Selecting the Installation Site.....	13
3.3 Mounting the Sampler.....	14
3.4 Attaching the Intake Line.....	14
3.4.1 Vinyl Intake Tubing.....	14
3.4.2 Teflon-Lined Polyethylene Intake Line.....	14
3.5 Setting Up the Intake Line and Strainer.....	15
3.6 Choosing Bottles.....	15
3.7 Installing the Full Bottle Shut-Off.....	15
3.8 Power Connections.....	16
3.9 12 V dc.....	17
3.10 Auxiliary Connection.....	17
<b>Section 4 Operation</b> .....	21
4.1 Keypad and Key Functions.....	21
4.2 Tips and Techniques for Programming the Instrument.....	22
4.3 Setting the Time and Date.....	23
4.4 Bottle Setup Mode.....	23
4.5 Explanations of Program Messages.....	24
4.6 Data Logging.....	25
4.7 Manual Mode.....	25
4.7.1 Manually Operating the Sample Pump.....	25
4.8 Measurements Triggered by Liquid Levels or Flow.....	26
4.9 Programming the Sampler for Level Control.....	27
4.10 Other Displayed Messages.....	27
4.11 Flow Proportional Operation.....	28
4.11.1 How to Calculate Pulses/Counts.....	28

# Table of Contents

---

<b>Section 5 Maintenance</b> .....	33
5.1 Cleaning the Sampler .....	33
5.1.1 Cleaning the Sampler Housing .....	33
5.1.2 Cleaning the Sample Bottles .....	33
5.1.3 Cleaning the Intake Tubing and Pump Tubing .....	33
5.1.4 No Lubrication Required .....	33
5.2 Pump Tubing Maintenance .....	33
5.3 Upgrades, Repairs, General Maintenance .....	33
5.4 Electrostatic Discharge (ESD) Considerations .....	33
5.5 Internal Maintenance Items .....	33
5.6 Removing and Opening the Controller .....	33
5.7 Re-installing the Bottom Panel .....	34
5.8 Internal Desiccant Module .....	35
5.9 Circuit Board Identification .....	35
5.10 Motor/Gear Box .....	36
5.11 Internal Case Humidity Indicator .....	36
5.12 Internal Case Humidity Indicator .....	36
5.13 Memory Battery .....	36
<b>Section 6 Contact Information for U.S.A. &amp; Outside Europe</b> .....	37
<b>Section 7 Contact Information for Europe</b> .....	38
<b>Section 8 Limited Warranty</b> .....	39
<b>Section 9 Parts and Accessories</b> .....	41
<b>Appendix A Programming Flow Chart</b> .....	43
Program Flow Chart .....	43
<b>Appendix B Batteries and Chargers</b> .....	45
Lead-Acid (Gel Cell) Batteries .....	45
Nickel-Cadmium Batteries .....	46
<b>Appendix C Exploded View Drawings</b> .....	47
Exploded View (1 of 6) .....	47
Exploded View (2 of 6) .....	48
Exploded View (3 of 6) .....	49
Exploded View (4 of 6) .....	50
Exploded View (5 of 6) .....	51
Exploded View (6 of 6) .....	52

# Section 1

# Specifications

Specifications are subject to change without notice.

<b>Controller Dimensions</b>	Height: 34 cm (13.5 in.), Width 28 cm (11 in.), Depth 20.3 cm (8 in.) without wall bracket, 33 cm (13 in.) deep with wall bracket
<b>Pump/Controller Housing</b>	High impact injection molded ABS: submersible, watertight, dust tight, corrosion and ice resistant; NEMA 4X, 6
<b>Sample Pump</b>	High speed peristaltic, dual roller, with 9.53 ID x 15.9 mm OD (3/8 in. x 5/8 in.) medical grade silicone rubber pump tube.
<b>Pump Body</b>	Impact/corrosion resistant, glass reinforced Delrin
<b>Vertical Lift</b>	8.23 m (27 ft) maximum. Remote pump option recommended for lifts from 6.7 to 10.7 m (22 to 35 ft)
<b>Sample Transport Velocity</b>	61 mm/sec. (2 ft/sec.) minimum, at 4.6 m (15 ft) vertical lift in a 3/8 in. ID intake tube
<b>Pump Flow Rate</b>	60 mL/sec at 0.91 m (3 ft) vertical lift in a 3/8 in. ID intake tube
<b>Sample Volume</b>	Programmed in milliliters, in one mL increments from 10 to 9999 mL
<b>Sample Volume Repeatability</b>	From 0.3 to 6.7 m (1 to 22 ft) vertical lift +/-5 mL typical for a 100 mL sample (+/- 5%)
<b>Sampling Modes</b>	Supports 1 bottle. Composite Time, Composite Flow, and Level Actuation
<b>Interval Between Samples</b>	Selectable in single increments from 1 to 9999 flow pulses (momentary contact closure 25 msec. or 5-12 V dc pulse; 4-20 mA interface optional), or 1 to 9999 minutes in one minute increments.
<b>Intake Purge</b>	Air purged automatically before and after each sample; duration automatically compensated for varying intake line lengths.
<b>Control Panel</b>	18 key, 31 function membrane switch keypad with 18 character alphanumeric, liquid crystal display. Self prompting/menu driven program.
<b>Internal Clock</b>	Indicated real time and date; 0.007% time base accuracy
<b>Programmable Delay</b>	Programmable sampler start time/date
<b>Manual Sample</b>	Initiates a sample collection independent of program process
<b>Data Logging</b>	Records program start time and date, stores up to 400 sample collection times/dates, all program entries, operational status including number of minutes or pulses to next sample, bottle number, number of samples collected, number remaining, sample identification number.
<b>Automatic Shutdown</b>	Composite Mode: After preset number of samples have been delivered to composite container, from 1 to 9999 samples, or upon full container.
<b>Intake Tubing</b>	6.4 mm (1/4 in.) and 9.5 mm (3/8 in.) ID vinyl to 9.5 mm (3/8 in.) ID Teflon-lined polyethylene with protective outer cover
<b>Intake Strainers</b>	Choice of Teflon and 316 stainless construction, and all 316 stainless steel in standard size and low profile for shallow depth applications
<b>Power Requirements</b>	12 V dc-supplied by optional ac power converter or battery. Average current draw with pump running: 2.25 amps dc, without pump running: 4 mA dc
<b>ac Power Backup</b>	Rechargeable 6 amp-hour gel lead acid battery takes over automatically with ac line power failure. Integral trickle charger maintains battery at full charge
<b>Internal Battery</b>	1.5 V <sub>dc</sub> lithium battery; maintains program logic and real time clock for five years. Internal battery current draws less than 40 micro amps
<b>Overload Protection</b>	5 amp dc line fuse; ac power pack; internal 1 amp ac line fuse
<b>Temperature Range</b>	General use: 0° to 50° C (32° to 122° F). LCD display operated from -10° to 70° C; Storage -40° to 80° C



### 2.1 Instrument Description

The instrument is designed to automatically collect and preserve samples from a liquid source. The sampler is suitable for collection of conventional and toxic pollutants and suspended solids.

The sampler collects samples on either a timed cycle basis, or in proportion to flow when used in conjunction with a flow meter (flow meter connected to the auxiliary connector). In the timed cycle mode, the interval between samples is controlled by an integral quartz crystal clock. The sample interval may be set from 1 to 9999 minutes, in one minute increments.

In the flow proportional mode, via an external flow meter, the interval between samples may be set from 1 to 9999 flow pulses, in one pulse increments. where each pulse represents a specific flow volume interval.

The number of minutes or flow intervals remaining until the next sample is shown on the control display. The program can be delayed by entering the desired starting time and date on the sampler keypad.

The sampler utilizes a high speed peristaltic pump, for collection of the sample liquid. The pump body is constructed of impact and corrosion resistant plastic. Tubing is held firmly in place by the pump body. No clamps are required. The intake line is air purged before and after each sample. The duration of the pre and post sample purge automatically compensates for different intake line lengths. The pump tubing is 0.95 cm (3/8 in.) ID X 0.32 cm (1/8 in.) wall medical grade silicone rubber. Although the pump is capable of vertical lifts up to 8.2 m (27 ft), lifts greater than 6.7 m (22 ft) are not recommended unless the Remote Pump option is utilized. The pump produces a sample transport velocity of 1 mps (3.3 fps) at 1 m (3 ft) vertical lift. The sample is under pumped flow at all times from the source stream to the sample container, thereby keeping solids in suspension.

### 2.2 Interface Connectors

The interface connectors are located on the left side of the controller housing. The sampler comes standard with two interface receptacles:

- 12 V dc (Power Input)
- Auxiliary (Multi-purpose input/output port)

#### 2.2.1 Receptacle Caps

Interface receptacles are covered with push-on receptacle caps. These caps protect the connector pins from dirt and moisture and should be attached to any receptacle not in use.

Figure 1 Interface Connectors

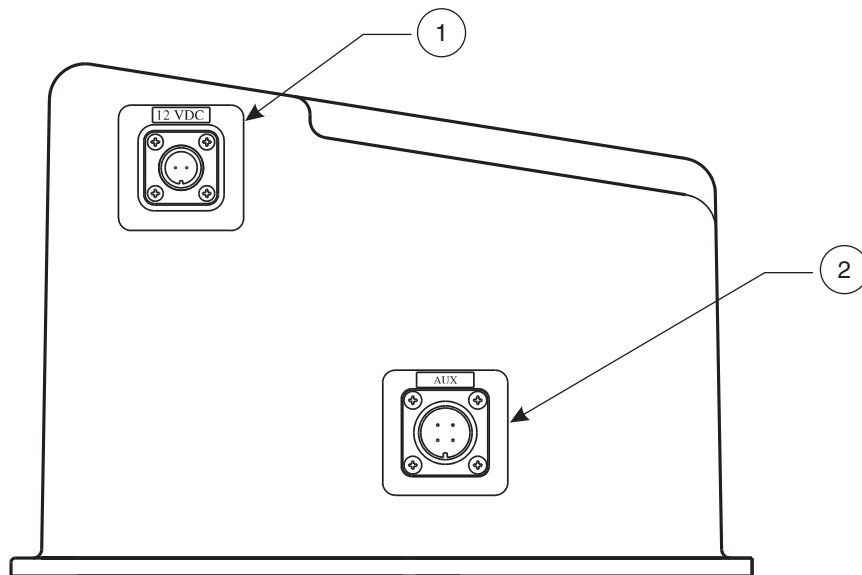

1. 12 V <sub>dc</sub>	2. Auxiliary
-----------------------	--------------

## 2.3 Front Panel

The front panel consists of the keypad, liquid crystal display, and the internal case humidity indicator ([Figure 2](#)).

### 2.3.1 Keypad and Display

The sampler controller is equipped with a 24 character alphanumeric liquid crystal display which automatically steps the user through the program settings.

### 2.3.2 Humidity Indicator

The internal case humidity indicator (Cat. No. 2660) turns pink when the internal case humidity exceeds 60 percent.

The sampler is equipped with an internal desiccant module (Cat. No. 8849) to absorb any humidity trapped in the case during final assembly. Under normal operating conditions, this desiccant provides long-term protection against condensed moisture inside the case.

Replacement of the internal desiccant module is only necessary if the indicator turns pink. See to [section 5.8 on page 35](#) for details.



Figure 2 900 Composite Sampler

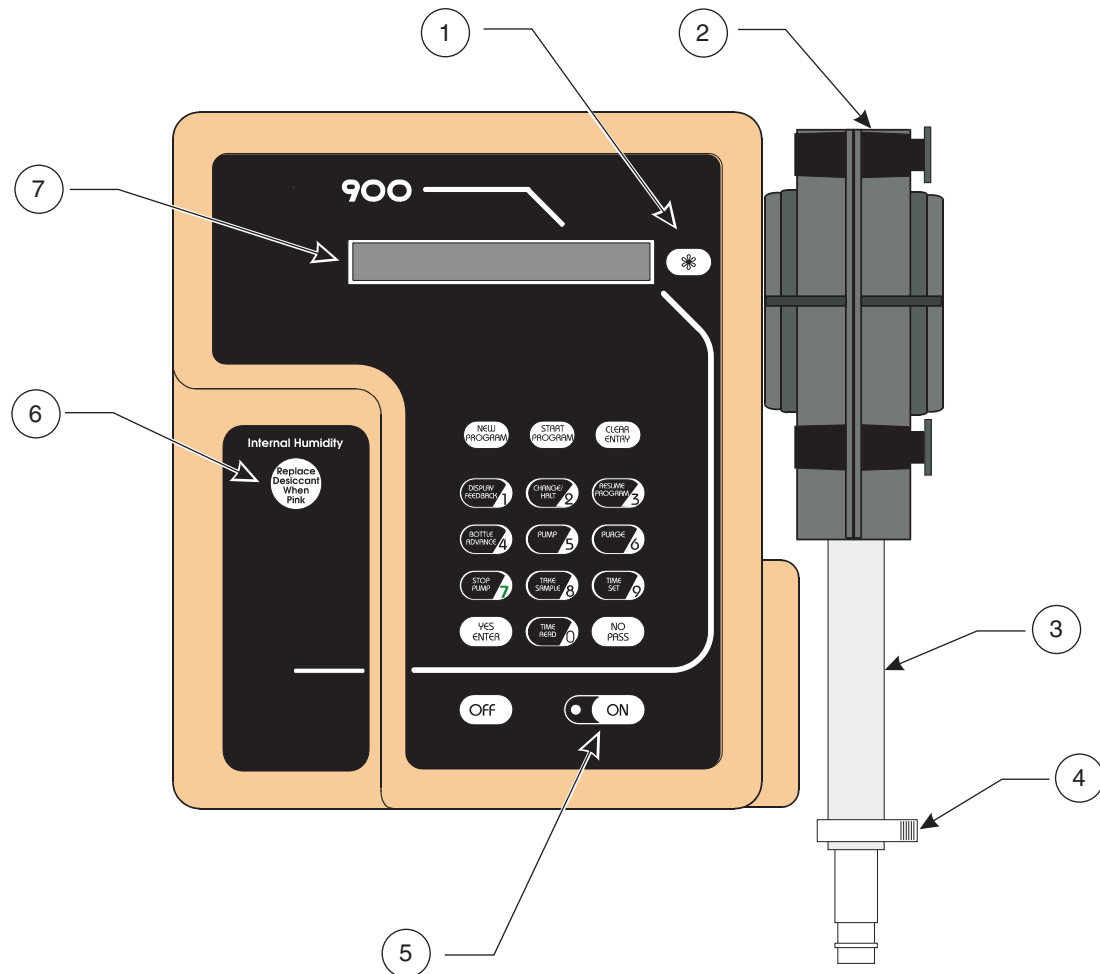

1. Function Key	5. Power On Indicator LED
2. Peristaltic Pump	6. Desiccant Indicator
3. Peristaltic Pump Tubing	7. 24-character Alphanumeric Liquid Crystal Display
4. Tubing Clamp	

## 2.4 Safety Information

Please read this entire manual before unpacking, setting up, or operating this instrument.

Pay particular attention to all danger and caution statements. Failure to do so could result in serious injury to the operator or damage to the equipment.

To ensure the protection provided by this equipment is not impaired, do not use or install this equipment in any manner other than that which is specified in this manual.

## Section 2

### 2.4.1 Use of Hazard Information

If multiple hazards exist, this manual will use the signal word (Danger, Caution, Note) corresponding to the greatest hazard.

#### **DANGER**

*Indicates a potentially or imminently hazardous situation which, if not avoided, could result in death or serious injury.*

#### **CAUTION**









*Indicates a potentially hazardous situation that may result in minor or moderate injury.*

#### **NOTE**

*Information that requires special emphasis.*

### 2.4.2 Precautionary Labels

Read all labels and tags attached to the instrument. Personal injury or damage to the instrument could occur if not observed.

	This symbol, if noted on the instrument, references the instruction manual for operation and/or safety information.
	This symbol, when noted on a product enclosure or barrier, indicates that a risk of electrical shock and/or electrocution exists and indicates that only individuals qualified to work with hazardous voltages should open the enclosure or remove the barrier.
	This symbol, when noted on the product, identifies the location of a fuse or current limiting device.
	This symbol, when noted on the product, indicates that the marked item can be hot and should not be touched without care.
	This symbol, when noted on the product, indicates the presence of devices sensitive to Electro-static Discharge and indicates that care must be taken to prevent damage to them.
	This symbol, when noted on the product, identifies a risk of chemical harm and indicates that only individuals qualified and trained to work with chemicals should handle chemicals or perform maintenance on chemical delivery systems associated with the equipment.
	This symbol, if noted on the product, indicates the need for protective eye wear.
	This symbol, when noted on the product, identifies the location of the connection for Protective Earth (ground).

### 2.4.3 Hazardous Locations

The 900 Composite Sampler is not approved for use in hazardous locations as defined in the National Electrical Code.

#### **DANGER**

*Although some Hach products are designed and certified for installation in hazardous locations as defined by the National Electrical Code, many Hach products are not suitable for use in hazardous locations. It is the responsibility of the individuals who are installing the products in hazardous locations to determine the acceptability of the product for the environment. Additionally, to ensure safety, the installation of instrumentation in hazardous locations must be per the manufacturer's control drawing specifications. Any modification to the instrumentation or the installation is not recommended and may result in life threatening injury and/or damage to facilities.*

**DANGER**

*Bien que certains produits Hach soient conçus et certifiés pour être installés dans des endroits dangereux tels que définis par le National Electric Code, de nombreux produits Hach ne conviennent pas pour de tels endroits. Il relève de la responsabilité des personnes qui placent les produits dans des endroits dangereux de déterminer s'ils sont adaptés à cet environnement. En outre, à des fins de sécurité, le placement de machines dans des endroits dangereux doit s'effectuer dans le respect des consignes des schémas de contrôle du fabricant. Toute modification apportée aux machines ou tout déplacement de celles-ci est déconseillé, car susceptible de provoquer des accidents matériels et/ou corporels.*

**PELIGRO**

*Aunque algunos productos Hach están diseñados y homologados para su instalación en entornos peligrosos, entendidos éstos conforme a la definición del "National Electrical Code" (Reglamento Eléctrico Nacional), muchos de los productos Hach no son aptos para su utilización en lugares peligrosos. Es responsabilidad de quienes instalen los productos en entornos peligrosos el asegurarse de la idoneidad de dichos productos para este tipo de entorno. Además, para garantizar la seguridad, la instalación de los instrumentos en lugares peligrosos deberá realizarse conforme a las especificaciones del plano del fabricante. Se desaconseja cualquier modificación de los instrumentos o de la instalación, ya que podría provocar lesiones corporales graves, e incluso fatales, y/o daños materiales a los equipos.*

**GEFAHR**

*Einige Hach-Produkte sind für den Einbau in explosionsgefährdeten Bereichen gemäß den Festlegungen des National Electrical Code speziell geprüft und zugelassen. Dies gilt jedoch keineswegs für das gesamte Hach-Produktangebot. Die Entscheidung, ob ein Produkt für den Einsatz in explosionsgefährdeten Bereichen geeignet ist oder nicht, bleibt in die Verantwortung des jeweiligen Installateurs gestellt. Im Interesse der Sicherheit ist es zudem erforderlich, dass ein etwaiger Einbau des Geräts in explosionsgefährdeten Bereichen genau nach den Steuerungsanlagen-Zeichnungen des Herstellers erfolgt. Von der Vornahme von Änderungen an meß- bzw. regeltechnischen Geräten bzw. abweichender Installation wird dringend abgeraten, da hierdurch lebensbedrohliche Personen- und/oder Sachschäden verursacht werden können!*

**PERICOLO**

*Nonostante alcuni prodotti Hach, siano predisposti e certificati per l'installazione in ambienti pericolosi, come previsto dal Codice Normativo Nazionale che concerne l'elettricità, è sconsigliabile utilizzare prodotti Hach in ambienti considerati pericolosi. E' diretta responsabilità della persona che installa lo strumento in un luogo ritenuto "pericoloso" appurare se lo strumento è compatibile con tale ambiente. Inoltre, per maggior sicurezza, l'installazione dello strumento in ambienti pericolosi deve seguire le specifiche di progettazione del produttore. Si deve evitare qualunque manomissione allo strumento o all'installazione, tali modifiche possono rappresentare una minaccia per la vita delle persone e creare guasti.*

**2.4.4 Confined Space Entry**

**Important Note:** *The following information is provided to guide users of 900 Composite Samplers on the dangers and risks associated with entry into confined spaces.*

On April 15, 1993, OSHA's final ruling on CFR 1910.146, Permit Required Confined Spaces, became law. This new standard directly affects more than 250,000 industrial sites in the United States and was created to protect the health and safety of workers in confined spaces.

### 2.4.5 Definition of Confined Space

A Confined Space is any location or enclosure that presents or has the immediate potential to present one or more of the following conditions:

- An atmosphere with less than 19.5% or greater than 23.5% oxygen and/or more than 10 ppm Hydrogen Sulfide (H<sub>2</sub>S)
- An atmosphere that may be flammable or explosive due to gases, vapors, mists, dusts, or fibers
- Toxic materials which upon contact or inhalation, could result in injury, impairment of health, or death

Confined spaces are not designed for human occupancy. They have restricted entry and contain known or potential hazards.

Examples of confined spaces include manholes, stacks, pipes, vats, switch vaults, and other similar locations.

Standard safety procedures must always be followed prior to entry into confined spaces and/or locations where hazardous gases, vapors, mists, dusts, or fibers may be present.

Before entering any confined space check with your employer for procedures related to confined space entry.

**DANGER**

Only qualified personnel should conduct the installation tasks described in this section of the manual

### 3.1 Unpacking the Instrument

Remove the sampler from the shipping carton and inspect it for any damage. Contact Hach Customer Service at 1-800-227-4224 if any items are missing or damaged.

### 3.2 Selecting the Installation Site

The sampler is completely self-contained and may be located indoors or outdoors without protection, between 0 to 50 °C (32 to 120 °F). Follow the guidelines below and [Figure 3](#) to allow complete drainage of the intake line and prevent cross-contamination between samples.

- Install the sampler as close to the source as site conditions permit. This will increase pump tube life and optimize overall sampler performance.
- Mount the sampler to a stable flat surface using the wall mounting bracket, Cat. No. 3596 ([Figure 4](#)).
- Install the sampler above the sample source, with the intake tubing sloping downward to the sample.
- Make sure the tubing is free of kinks or loops.

**Figure 3** Placement of the Sampler

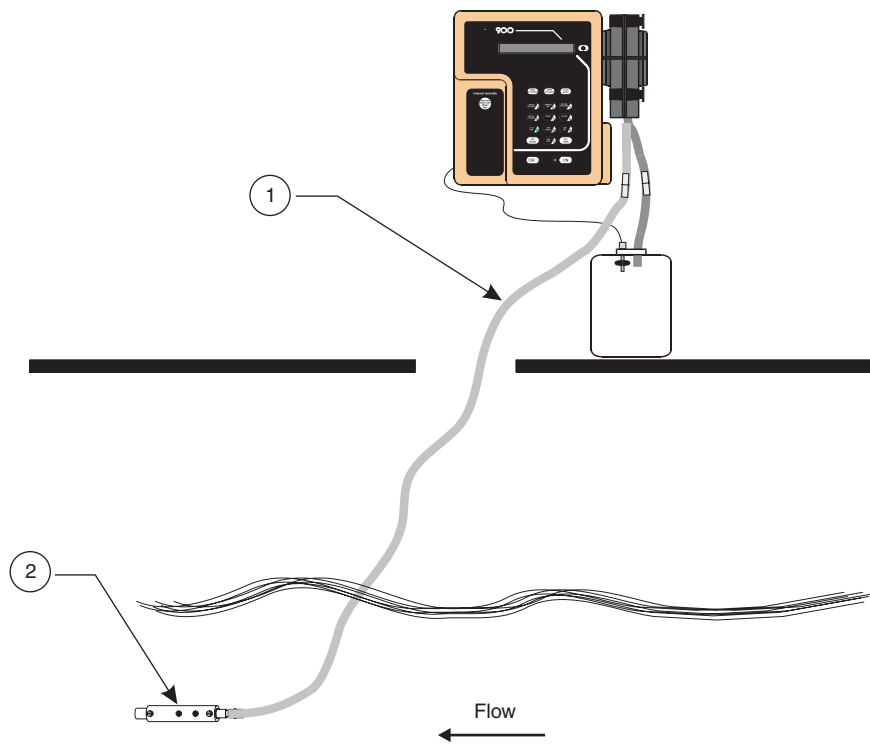

- |   |
|---|
| 1. Slope tubing down to source (no loops, kinks, or excess tubing). |
| 2. Locate strainer in an area of turbulent and well-mixed flow.     |

Figure 4 Wall Mount Bracket

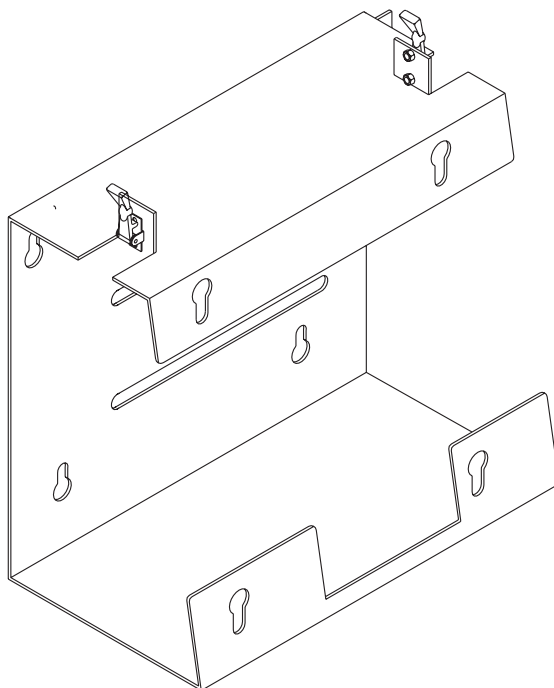

### 3.3 Mounting the Sampler

Attach the wall mount bracket to a stable panel or wall ([Figure 4](#)). Mount the bracket so the sample display and keypad are easily accessible. Mount the sampler to the wall bracket using the four screws provided.

### 3.4 Attaching the Intake Line

#### 3.4.1 Vinyl Intake Tubing

1. Push one end of the clear flexible PVC (vinyl) tube to the tapered end of the intake strainer, until the tube is within 0.635 cm ( $\frac{1}{4}$  in.) of the solid white Teflon strainer body.
2. Push the other end of the vinyl tube on to the stainless steel fitting connector end that points away from the pump control housing.

#### 3.4.2 Teflon-Lined Polyethylene Intake Line

The Connection Kit for Teflon-lined Tubing (Cat. No. 2186) contains two identical assemblies, one for connecting the Teflon-lined tubing to the stainless steel tubing connector and the other for connecting the intake strainer.

1. Place the stainless steel hose clamp over the stainless steel fitting until it abuts the shoulder of the tubing connector. Secure with a tubing clamp.
2. Push the stainless steel fitting into the Teflon-lined tubing until it abuts the shoulder of the stainless steel fitting.
3. Slide the stainless steel hose clamp over the silicone tubing, then push the silicone tubing over the stainless steel fitting on the liquid sensor.

4. Slide the tubing clamp over the silicone tubing until it is over the stainless steel fitting on the liquid sensor. Tighten to secure.
5. Repeat the procedure for the intake strainer.

### 3.5 Setting Up the Intake Line and Strainer

For each sampling location, the intake line should be as short as practical, and be free of any sharp bends, coils, or loops. Install the intake line with a downward slope from the sampler to the sample source because:

- This will assure the complete drainage of the intake line when it is air-purged before and after each sample, and will help to prevent cross-contamination of the individual samples.
- Complete drainage is important in freezing conditions, as any liquid slugs that remain could freeze and plug the line.

Place the sample intake and strainer in the mainstream of the sampling source, in an area of turbulent and well-mixed flow.

Also, take in account the vertical location of the intake. A position too near the surface may yield excess lighter materials, while a position too near the bottom may yield excess heavy materials. The constituents of interest must be considered when positioning the intake strainer.

### 3.6 Choosing Bottles

A broad range of bottle configurations are available for the 900 Composite Sampler. Refer to

Size	Material
9.5 L (3 gal)	Polyethylene
11.4 L (2.5 gal)	Glass
15.1 (4 gal)	Polyethylene
20.1 L (5.5 gal)	Polyethylene
22.7 L (6 gal)	Polyethylene

### 3.7 Installing the Full Bottle Shut-Off

Install the optional full bottle shut-off into the bottle cap using the attached rubber grommet. Install the full bottle shut-off connector to the mating plug which is attached to the sampler back panel. Insert the sample tubing into the cap of the bottle.

Figure 5 Full Bottle Shut-off

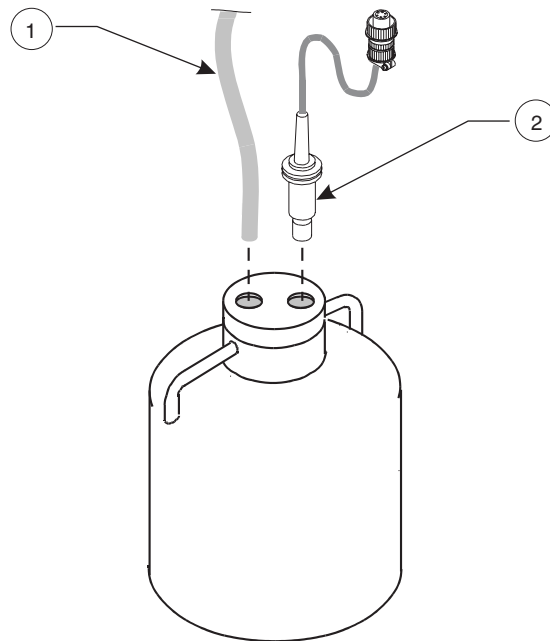

1. Sample Tubing	2. Full Bottle Shut-off
------------------	-------------------------

### 3.8 Power Connections

The sampler controller operated on 12 V dc which is supplied by an optional ac/dc power converter and/or battery.

**Note:** Make sure both rubber hold-downs are attached to the clips at each end of the power supply.

The power supply (or battery) is placed in the compartment located directly behind the controller. Pull the rubber hold-downs up and over the clips at each end of the power supply (or battery) to hold it in place.

The short 2-pin cable on the power supply (or battery) connects the controller receptacle labeled 12 V dc.

Batteries available from the manufacturer include a lead-acid gel battery, and nickel-cadmium (Ni-Cad) battery (Cat. No. 1416). The 120 V ac to 12 V dc power converter (Cat. No. 1440) includes a built-in lead-acid battery charger. The Power Converter (Cat. No. 1443) contains a charger for Ni-Cad batteries. 230 V ac and 12 V dc power converters (Cat. No. 1441) are also available but do not come equipped with a built-in battery charger. Stand-alone, wall mount chargers are also available. See APPENDIX for details on batteries and battery charging.

**Important:** Whenever electricity is present, there is a possibility of electrical shock. Before connecting the sampler to an ac power source, the following safety precautions should be taken:

- Check the power source to make sure that it satisfies the ac power requirements of the sampler.
- Make sure that all electrical installations and connections are in accordance with national and local electrical codes.



- Before performing any maintenance, disconnect the sampler from the power source.
- Do not attempt to make any connection or otherwise handle the electrical components of the sampler when connected to ac line power if the immediate area is wet, or if hands or clothing are wet.
- If the circuit breaker or fuse in the ac power source is tripped, determine the cause before restoring power to the sampler.
- Make sure the power circuit is grounded and protected with a Ground Fault Interrupter (GFI).

### 3.9 12 V dc

This connection is for supplying power to the sampler controller electronics. Power is normally supplied to the sampler controller electronics from either a battery or a power supply located in the pocket directly behind the sampler controller housing.

In the event of a power outage, an optional 12 V dc battery backup is available (Cat. No. 1803). This power backup maintains power to the sampler when ac power fails.

**Table 1 12 V dc Connector Pin Assignments**

Pin	Signal Description
A	ground
B	12 to 17 V dc unregulated

### 3.10 Auxiliary Connection

The auxiliary interface connector is a general purpose input/output port. Each signal is described in [Table 2](#).

**Table 2 Auxiliary Pin Assignments**

Pin	Signal Description	Wire Color	Purpose	Rating
A	12 V dc	White	This pin can be used to power an external device or flow meter. Must be used in conjunction with Pin B (ground).	13.8 V dc nominal
B	ground	Blue	Connected to dc ground and is isolated from the earth ground found in the ac power line.	
C	Flow Pulse Input	Yellow	With the sampler is in Flow Proportional mode and connected to an external flow meter, a 5 to 12 V dc input pulse lasting at least 25 milliseconds will cause the sampler to decrement one count. The sampler is capable of accumulating from 1 to 9999 input pulses. The 12 V dc line found on Pin A can be used directly with a simple contact closure to Pin C or an external 5 to 12 V dc pulse may be applied providing the ground side of the external signal is connected to the sampler ground at Pin B. This count is actuated at the beginning of the input signal (the leading edge of the pulse).	5 to 17 V dc pulse with duration of at least 25 ms.

**Table 2 Auxiliary Pin Assignments**

Pin	Signal Description	Wire Color	Purpose	Rating
D	Liquid Level Actuator/Auxiliary Control Input	Black	This line is held at 5 V dc inside the sampler. When shorted to ground (Pin B), a signal is sent to the microprocessor inside the sampler causing it to “wake up” and begin or resume the sampling program. It can be used in conjunction with a simple level float switch to actuate the sampler when liquid is present or to take over after a second sampler had finished its program. It may also be used with any device (such as pH meter) which produces a dry contact output to control the sampler in response to some user defined condition (i.e. high or low pH); must be used in conjunction with Pin B (ground).	24 V dc (max) at 100 mA (max)
E	Special Output	Red	Normally at 0 V dc, this line switches to 12 V dc upon any of the selected event described in SECTION, PROGRAMMING.	N/A
F	Program Complete Output	Green	Normally an open circuit, this line switches to ground for 90 seconds at the conclusion of the sampling program. Used to “wake up” another sampler to take over sampling or to signal an operator or datalogger upon the completion of the sampling program.	N/A

### Contact Closures

The sampler controller is capable of accumulating 1 to 9999 contact closures. Each contact closure output from a flow meter represents a specific flow volume.

**Note:** The sampler provides 12 V dc on Pin A of the Auxiliary Receptacle and this voltage is pulsed back to Pin C each time the contact closes on the external flow meter. The external flow meter must provide a dry contact closure.

Some flow meters have an adjustable output, i.e. one contact closure for every 100, 500, 1000, 10, 000 gallons of flow, etc., while others have a fixed output. In either case, the contact closure signal is sent more frequently for high flow rates, and less frequently for low flow rates. The sample frequency will increase as the flow rate increases and likewise, will decrease as the rate of flow decreases, thus taking samples in proportion to flow rate.

To connect the sampler to a flow meter, use Signal Cable (Cat. No. 940 or 540). To connect another brand of flow meter, use the Open-ended Signal Cable (Cat. No. 941 or 541). A contact closure input signal corresponds to Pins A and C on the Flow Meter/Auxiliary receptacle, and signal cable connector. The signal cable wires are white and yellow respectively. Polarity is not important unless the same closure signal is sent to more than one sampler.

### 4–20 mA Input

**Note:** Older model 4–20 mA interfaces (Cat. No. 913) require correct loop polarity to properly work. The newer generation (Cat. No. 2020 series) interfaces are not sensitive to loop polarity.

An optional interface unit is available (Cat. No. 2021) which converts a 4–20 mA flow meter output into a 12 V dc pulses. At 20 mA (100% flow rate), the interface sends ten pulses per minute; at 4 mA (0% flow rate), the interface sends zero pulses.

The interface has a 0.9 m (3 ft) cable with connector on one end, and a 3 m (10 ft) cable with two open wire leads on the other. Insert the connector into the sampler receptacle labeled “AUXILIARY”, located on the left side of the control housing. For the 3 m (10 ft) cable, the wire with clear insulation is POSITIVE (+) and the wire with black insulation is NEGATIVE (–).

**Figure 6** 4–20 mA Interface and Pulse Duration Input

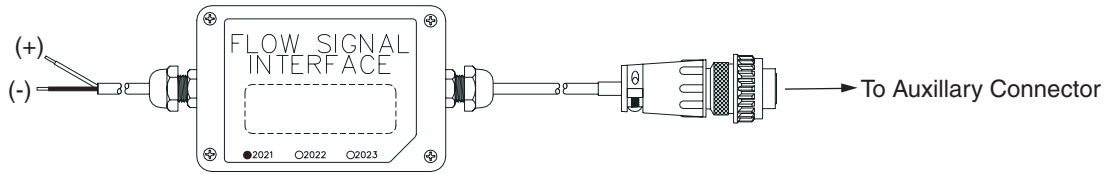

For details on programming the sampler for flow proportional operation, refer to SECTION.

#### Splitter Interface

This splitter interface (Cat. No. 939) can be used if access to more than one of the Auxiliary Receptacle functions is required simultaneously. Connecting the interface to the 6-pin connector on the sampler provides three additional connectors for use. Two or more interfaces may be connected in series to allow for as many connections as desired.

**Figure 7** Splitter Interface

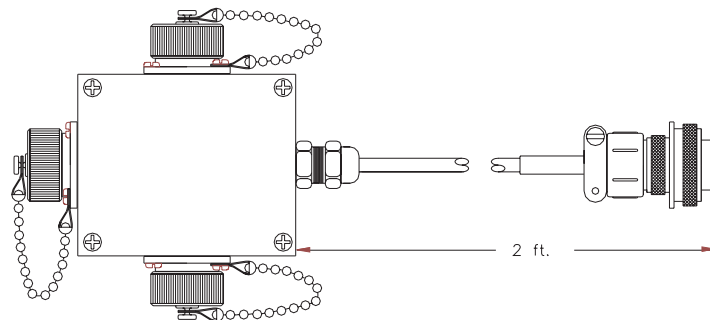



## 4.1 Keypad and Key Functions

Figure 8 shows the 18-position keypad and 24-character alphanumeric display.

Button	Function
<b>ON</b>	Energizes Sampler
<b>OFF</b>	De-energizes sampler and halts program in progress
<b>START PROGRAM</b>	Initiates the sampling program and resets all counts to zero (including datalogger). When the START PROGRAM button is pressed, all recorded data (program entries and collected sample times/dates) are erased from memory. Always download recorded data before pressing START PROGRAM.
<b>NEW PROGRAM</b>	Allows input of new sample program...programming choices appear on display.
<b>YES/ENTER</b>	Causes a positive response when a question appears on display; accepts new programmed value or previously entered value.
<b>NO/PASS</b>	Causes a negative response when a question appears on display; in standby state, the software revision number is displayed.
<b>CLEAR ENTRY</b>	Erases program value shown on display; when held for two seconds, permits enable/disable of level actuation/auxiliary control.
<b>DISPLAY FEEDBACK</b>	Displays program status and a review of the program.
<b>CHANGE/HALT</b>	Stops sampler program and places in standby state. When started, press this key prior to making any program change and before pressing keys 4, 5, 6, 7, 8, 9, and NEW PROGRAM.
<b>RESUME PROGRAM</b>	Causes the program to continue from the point at which it is halted.
<b>BOTTLE ADVANCE</b>	Feature not available with this model.
<b>PUMP (Manual Mode)</b>	Pumps sample liquid (pump forward) when held. Pump stops when released.
<b>PURGE (Manual Mode)</b>	Purges sample liquid (pump reverse) when held. Pump stops when released.
<b>STOP PUMP (Manual Mode)</b>	Stops pump when using PUMP LOCK (see *). When held for 3 seconds (with sampler in a standby state), permits selection of other languages.
<b>TAKE SAMPLE</b>	Initiates sample cycle independent of program.
<b>TIME SET</b>	Allows setting real time and date
<b>TIME READ</b>	Causes real time and date to appear on display. When held for 3 seconds, display indicated time and date each sample was taken (or missed).
<b>* (asterisk)</b>	During programming, causes program to back-step. After CHANGE/HALT, allows altering of bottle parameters (container volume, etc.). After CHANGE/HALT, provides review of parameters (i.e. number of bottles, volume of bottle(s), line length, etc.). After PUMP/PURGE, (manual mode) activates PUMP LOCK. Pump runs forward (KEY 5) or reverse (KEY 6) without holding key. KEY 7 stops the pump.

Figure 8 Front Panel

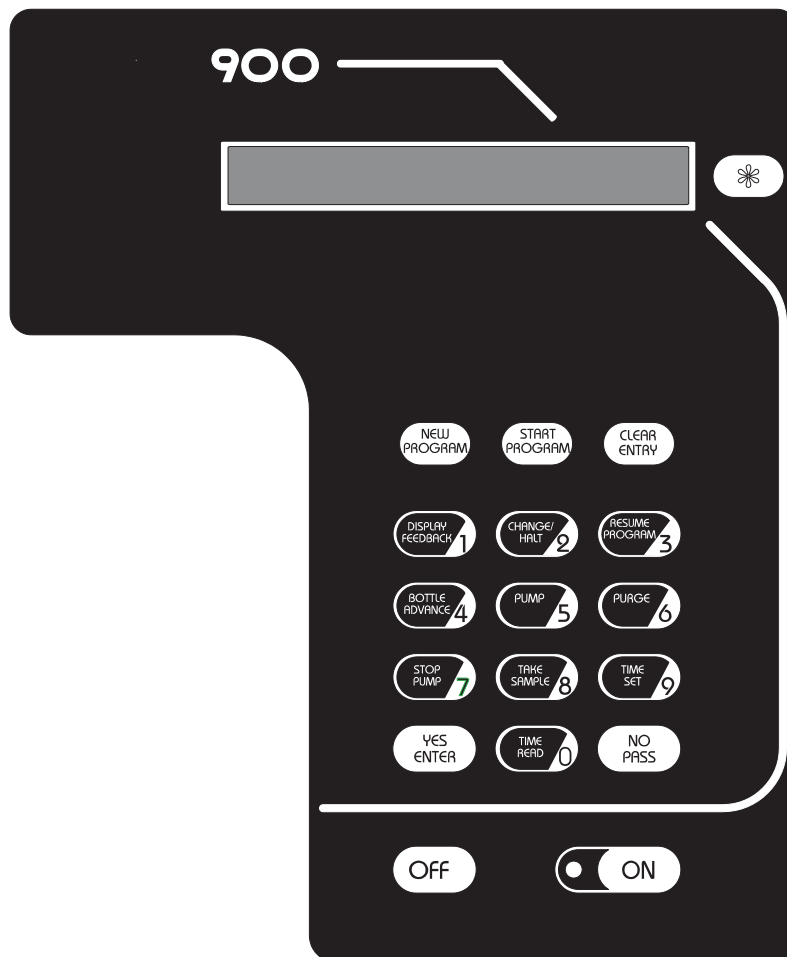

### 4.2 Tips and Techniques for Programming the Instrument

- The instrument beeps each time a key is pressed.
- After the ON button is pressed, the display will show one of the following messages: "Program Halted", "Program Running", "Program Complete", or "Ready to Start".
- The program status changes to Program Complete when sampling is complete and there are no samples to be taken or the optional full bottle shut-off is actuated.
- When the program is stopped (and no changes to the program settings were made while it was stopped), pressing the **START PROGRAM** key will prompt to resume the previously running program (and retain all logged data) or Start From Beginning (and clear all logged data).
- When programming the instrument, pressing the \* key causes the display to back up to the previous field.

### 4.3 Setting the Time and Date

Before programming the sampler for the first time, check the real time clock and date settings.

**Note:** When setting the time and date, the \* key causes the display to back up to the previously flashing character.

1. Check the real-time clock and date settings by pressing **TIME/READ**. The display will show the time and date for several seconds:  
**10:35 AM 24OCT00**
2. If the time or date are not correct, press **TIME/SET**. The time and date will appear on the display, with the hour flashing.
3. Press the appropriate numerical key(s) for the correct hour. When the correct hour flashes on the display, press **YES**. This will cause the minutes to flash on the display.
4. Using the same procedure, select the correct minutes and press **YES**. The am/pm indicator will flash.
5. If the desired indicator is flashing on the display, press **YES**. If the desired indicator is not flashing, press **NO**. This will cause the other indicator to flash.
6. Press **YES**. The month will begin to flash. Select the correct day, month and year using the same procedure as you used to set the time.
7. After the correct year has been entered, the display will read "Synchronize Time-enter at Time". Pressing **YES** will start the clock. The display will read "Clock is Now Set".

### 4.4 Bottle Setup Mode

When programming the sampler for the first time, you must first access the bottle setup mode which contains set-up information such as the units for bottle volume (milliliters and gallons) and the bottle volume.

To access the Bottle Setup Mode, the sampler must be in standby state, the program cannot be in progress or "running". The sampler is in standby state when the display indicated any one of the following: "Ready to Start", "Program Complete", or "Program Halted". If the display reads "Program Running", press the **CHANGE/HALT** key. This will halt the program, thus placing the sensor in the "Program Halted" standby state.

1. With the sampler in standby state, press the \* key. The display will read "Enter units for bottle volume, milliliters?".
2. Press **NO** to cause other volume units to appear. When the desired units appear on the display, press **YES**.
3. The display will show "Volume = \_ \_ \_ \_ mL" (or "Volume = \_ \_ \_ \_ Gallons"), whichever was chosen in the previous step.
4. Enter the volume for the individual sample bottle by pressing the numerical keys.
5. Press **YES** to accept the volume.

This completes the bottle setup entries and the sampler is ready to program.

## 4.5 Explanations of Program Messages

Item Number	Message	Description of Message
1	<b>READY TO START</b>	Indicates that a program is ready to start. To start, press <b>START PROGRAM</b> .
2	<b>PROGRAM HALTED</b>	Indicates the sampling program has been interrupted.
3	<b>PROGRAM RUNNING</b>	Indicates that a program is in process. Keys <b>0</b> , <b>1</b> and <b>2</b> are the only active keys while a program is running. If running, halt the program (press <b>HALT PROGRAM</b> ) before entering a new program.
4	<b>PROGRAM COMPLETE</b>	This message is displayed after program completion. To repeat the program, press <b>START PROGRAM</b> . Press <b>NEW PROGRAM</b> to enter a different program.
5	<b>RE-ENTER PROGRAM, DEPRESS *</b>	When the sampler is on, this message will appear if the sampler was turned off during program entry.
6	<b>PROGRAM DELAY</b>	This is the first message in the programming sequence. If selected, the sampler will start only after the delay period elapses. A <b>YES</b> response causes message 6a to appear on the display.
6a	<b>10:35 AM 21JUL03</b>	A time and date are displayed when <b>YES</b> is pressed in response to message 6. The example to the left signifies 10:35 in the morning, on October 24, 2000.
7	<b>TIMED MODE</b>	If selected, the sampler will operate on a timed cycle basis. Press <b>YES</b> to prompt the user to enter the number of minutes desired for the time interval between samples. Press <b>NO</b> to prompt the question described in item 8.
7a	<b>INTV = ____ MIN</b>	Enter the value for the interval between samples (in minutes).
8	<b>FLOW MODE?</b>	Press <b>YES</b> , the cause the sampler to operate on a flow proportional basis. It will prompt the you to enter the number of flow signals that you want the sampler to count down between samples. Press <b>NO</b> to prompt the question in item 7.
8a	<b>INTV = ____ CNTS</b>	Enter the value for the number of pulses (counts) that you want to accumulate between samples. To determine the appropriate number, refer to the programming instructions for flow proportional operation in <a href="#">section 4.11</a> .
9	<b>OTHER CHANGES</b>	Press <b>NO</b> to retain the previously entered program entries for all remaining programming steps, and return to the "Ready to Start" standby state. Press <b>YES</b> to change the previously programmed entries for all items 10 through 16.
10	<b>COMPOSITE MODE, CONTINUOUS MODE</b>	This message appears if only one bottle is entered for the total number of bottles in the parameter entry mode. Press <b>YES</b> to the "Continuous Mode?" prompt to take samples at the programmed interval. The program will terminate only with a full bottle when using the full bottle float switch (Cat. No. 8847). Press <b>NO</b> to cause the display to read "samples = ____". This permits you to enter the desired number of samples, after which the program will terminate.
11	<b>CHANGE VOLUME?</b>	Press <b>NO</b> to retain the sample volume from the previous program (programming items 13, a–h are skipped), and the display will prompt the message in item 14.
12	<b>SAMPLE VOL = ____</b>	Enter the desired sample volume (in mL) to be delivered to the sample container each time a sample is initiated.
13	<b>CALIBRATE VOL?</b>	This message appears after you enter sample volume. If greater volume accuracy is desired, press <b>YES</b> . Press <b>NO</b> to skip the calibration and go to the next step.
13a	<b>READY TO PUMP?</b>	When <b>YES</b> is pressed the sampler will pump to collect one sample. The pump will first pre-purge the intake line, draw sample liquid, and then post-purge. Before pressing <b>YES</b> , pull the pump tubing off of the fitting where it enters the sampler housing and place a graduated cylinder at the sample discharge point.
13b	<b>STOP AT MARK</b>	After pressing <b>YES</b> in response to item 13a, the pump will pre-purge the intake line and begin pumping liquid into the graduated container. When the desired volume has been delivered, press <b>STOP PUMP</b> . The pump will then purge the intake tubing. The sampler will hold the time to deliver the desired sample volume in memory. This timed volume is repeated for subsequent samples.



Item Number	Message	Description of Message
13c	TRY AGAIN?	If <b>STOP PUMP</b> was pressed before or after the desired rinse time, press <b>YES</b> to initiate another rinse cycle. Press <b>NO</b> to view item 16.
14	ENTER ID#	Enter an optional identification number if desired.
15	SETUP COMPLETE, READY TO START	This message indicates that all programming steps have been completed. Press <b>START PROGRAM</b> to begin. The display will read "Program Running". To review the program operating status, press <b>DISPLAY FEEDBACK</b> . When you press <b>START PROGRAM</b> , all recorded data are erased from memory. Always download recorded data before pressing <b>START PROGRAM</b> .

## 4.6 Data Logging

The sampler records the time and date that each sample was collected, up to 400 samples. It also records the time and date of up to 24 missed samples.

1. To access information, the sampler must be in the "Program Halted" or "Program Complete" standby state.
2. Press **TIME/READ** for two seconds. The display will read "Samples Taken".
3. To display the time/date for each sample, press **YES**. To advance to the next sample time/date, press **YES** again—and so forth, until all are given.
4. To exit this routine, press **NO**. The time and date of any missed samples are displayed after collected samples.

The sampler memory incorporates the "wrap around" method of data storage. That is, when the memory becomes full, the oldest stored data (sample number, time/date) are dropped as new data are received. The data logger retains the 400 most recent times/dates for the collected samples.

## 4.7 Manual Mode

### 4.7.1 Manually Operating the Sample Pump

1. To manually operate the pump, place the sampler in standby state. The sampler is in standby state when the display reads "Ready to Start", "Program Halted", or "Program Complete".
2. To operate the pump, press either the **PUMP** or **PURGE** key. This will cause "Manual Mode - Pump/Purge/Clear" to appear on the display. Pressing the **PUMP** key causes the pump to run in the forward (sample) direction as long as the key is held. Pressing the **PURGE** key causes the pump to run in the reverse (purge) direction.
3. To run the pump continuously in either direction without having to hold down the **PUMP** or **PURGE** keys, press the \* key. This will cause "Lock-Pump/Purge" to appear on the display. Then press either **PUMP** or **PURGE**.
4. To stop the pump, press **STOP PUMP** or turn the sampler off with the **OFF** key. Pressing **STOP PUMP** returns the display to "Pump/Purge/Clear".

5. To exit the manual mode, press **CLEAR ENTRY**. This returns the sampler to the standby state.

While the sampler is in standby, a sample cycle can be initiated by pressing the **TAKE SAMPLE** key.

### 4.8 Measurements Triggered by Liquid Levels or Flow

The sampler can operate in any one of three control modes, using an external controlling device (i.e. Liquid Level Actuator, Cat. No. 943, or an external flow meter). In any of the three modes, the sampler remains in a standby state until liquid at the sample source reaches a predetermined level. This feature may be also used to access the setup of the storm water monitoring program, First Flush. The three modes are described below:

#### **Mode 1**

The instrument collects a sample within the first minute that the liquid rises to the predetermined level. After the first sample is taken, the sample interval automatically resets to the programmed interval.

If the liquid falls below the predetermined level, the sampler continues to collect samples at the programmed time or flow interval, until the program ends.

#### **Mode 2**

The instrument collects a sample within the first minute that liquid rises to the predetermined level. After the first sample is taken, the sample interval automatically resets to the programmed interval. The sample program ends if liquid falls below the predetermined level. If the liquid again rises to the predetermined level, a sample is taken within the first minute and the interval automatically resets to the programmed time or flow interval.

#### **Mode 3**

When the liquid rises to a predetermined level, a sample is not taken immediately. A sample is taken only when liquid is at or above the predetermined level and after the programmed sample interval has elapsed. The interval between samples counts down and resets even when the liquid level is below the predetermined (actuation) level. This mode is used to synchronize sample collection with a real-time clock when sampling in the time mode.

## 4.9 Programming the Sampler for Level Control

Put the sampler in a standby state (i.e. "Program Halted", "Ready To Start" or "Program Complete") hold **CLEAR ENTRY** for two seconds. This will cause the display to read "Level Control?". The following messages may be displayed in the level control program:

Item Number	Message	Description of Message
1	<b>LEVEL CONTROL</b>	If you press <b>NO</b> , <b>SPECIAL OUTPUT?</b> will appear on the display. If you press <b>YES</b> , the display shows item 2.
2	<b>LEVEL START?</b>	If you press <b>YES</b> , the sampler operates as described in Mode 1. If you press <b>NO</b> , the display shows item number 4.
3	<b>LEVEL START/STOP</b>	If you press <b>YES</b> , the sampler operates as described in Mode 2. If you press <b>NO</b> , the display shows item number 5.
4	<b>SAMPLE ON LEVEL?</b>	If you press <b>YES</b> , the sampler operates as described in Mode 3. If you press <b>NO</b> , the display shows item number 1.

***Note:** In addition to the liquid level actuator, a Multi-purpose Half cable (Cat. No. 941 or 541) may be used to connect the sampler to any controlling device which produces a dry contact closure upon a predetermined conditions. For example, a pH meter with adjustable high/low set points can be used to control sampler operation in any of the three level/auxiliary control modes.*

## 4.10 Other Displayed Messages

Message	Description of Message
<b>YES/NO or * TO BACKUP</b>	This message appears if a key other than <b>YES</b> or <b>NO</b> is pressed and the displayed message is followed by a question mark while in the Parameter Entry, Programming Running, or Time Set modes.
<b>WHILE RUNNING, KEY 0 - 1 - 2 ONLY</b>	This message appears if a key other than <b>0</b> , <b>1</b> , or <b>2</b> is pressed while the program is running. The program must be halted (press the <b>2</b> key) before any manual operations are performed, such as Bottle Advance, Pump, Purge, Take Sample, New Program, etc.
<b>REVIEW RESULTS?</b>	This message appears if <b>DISPLAY FEEDBACK</b> is pressed and the sample program has been halted. A <b>YES</b> response will cause the sample program results to appear. A <b>NO</b> response causes <b>REVIEW PROGRAM?</b> to appear.
<b>REVIEW PROGRAM?</b>	If you press the <b>YES</b> key, all programmed settings will appear on the display. Pressing the <b>NO</b> key will place the sampler back into the standby state.
<b>LOW BATTERY</b>	This message indicates that the external battery is low and requires recharging.
<b>MEMORY POWER LOW</b>	This message indicates that the internal lithium battery is low and needs to be replaced.
<b>PROGRAM STOPPED DUE TO FULL BOTTLE</b>	During composite mode, this message appears upon a full bottle condition. The program cannot be restarted until the composite container is emptied and the float switch is in the lowered position.
<b>BOTTLE IS FULL</b>	If your instrument is programmed for single container composite sampling, this message appears if the <b>START PROGRAM</b> key is pressed and the float switch is not in the lowered position. Because the same circuit path is used for the composite full bottle float switch (composite mode) and #1 bottle indicator (multiple bottle mode), this message will also appear if the <b>START PROGRAM</b> key is pressed with the sampler programmed for single container composite with the distributor assembly in place, and the arm in the #1 bottle position. To correct this situation, remove the distributor, install the composite container retainer, and press the <b>START PROGRAM</b> key.
<b>FULL BOTTLE or PROGRAM HALTED DUE TO FULL BOTTLE</b>	The full bottle float switch is in the raised position due to a full composite container. To resume the program, exchange the full container with an empty one. With the float switch in the lowered position, the program will resume within one minute.

### 4.11 Flow Proportional Operation

#### 4.11.1 How to Calculate Pulses/Counts

##### 4.11.1.1 Flow Proportional Sampling Intervals—Using External Pulses

The sampler is equipped to receive either a momentary dry contact closure or a +5 to +12 V dc pulse from a flow meter, where each pulse represents a known flow increment.

For example, if the flow meter is set to send a flow pulse for every 1000 gallons of measured flow and the sampler can count 1 to 9999 flow pulses between sample intervals, the sampler can be programmed to receive 10 pulses between samples to take one sample for every 10,000 gallons of liquid flow.

To determine the number of flow pulses between sample intervals, determine the total number of samples (represented by  $n$  in the following examples) to be collected, and the period of time over which they are to be collected. Also know the total flow,  $Q$ , during the sampling program. The following two-step method should be useful for determining the value for **INTV = \_\_\_\_\_ CNTS** during setup.

1. Determine  $f$ , where  $f$  represents the flow increment between samples and  $n$  represents the total number of samples to be collected.

$$f = \frac{Q}{n}$$

2. Multiply the flow increment between samples,  $f$ , by the pulse frequency output of the flow meter (i.e. 1 pulse per 100 gallons, 1 pulse per 1,000 gallons, etc.). If the pulse frequency output of the flow meter is not known, consult the flow meter manufacturer.

**Note:** The final result is not necessarily a whole number. You must round off the result to the nearest whole number.

##### Example 1

You want to collect 35 samples over a 24-hour period. The total expected flow over this period is 235,000 gallons. The flow meter pulse frequency is one pulse for every 100 gallons.

1. Determine the flow increment between samples:

$$f = \frac{Q}{n} = \frac{235,000 \text{ gallons}}{35 \text{ samples}} = 6,714 \text{ gallons/sample}$$

2. Multiply the flow increment,  $f$ , by the pulse frequency output of the flow meter.

$$6,714 \text{ gallons/sample} \times \frac{1 \text{ pulse}}{100 \text{ gallons}} = 67.14 \text{ pulse/sample}$$

Therefore, the value for **INTV = \_\_\_\_\_ CNTS** is 67.  
(67.14 is rounded off to 67.)

##### Example 2

You want to collect 24 samples over an 8-hour period. The total expected flow over this 8-hour period is 85,000 gallons. The flow meter pulse frequency output is one pulse for every 50 gallons.

1. Determine the flow increment between samples:

$$f = \frac{Q}{n} = \frac{85,000 \text{ gallons}}{24 \text{ samples}} = 3,542 \text{ gallons/sample}$$

2. Multiply the flow increment,  $f$ , by the pulse frequency output of the flow meter.

$$3,542 \text{ gallons/sample} \times \frac{1 \text{ pulse}}{50 \text{ gallons}} = 70.84 \text{ pulse/sample}$$

Therefore, the value for **INTV** = \_ \_ \_ \_ **CNTS** is 71.

### Example 3

You want to collect 48 samples over a 16-hour period. The total expected flow over this period is 1,750,000 gallons. The flow meter pulse frequency output is one pulse for every 1,000 gallons.

1. Determine the flow increment between samples:

$$f = \frac{Q}{n} = \frac{1,750,000 \text{ gallons}}{48 \text{ samples}} = 36,458 \text{ gallons/sample}$$

2. Multiply the flow increment,  $f$ , by the pulse frequency output of the flow meter.

$$36,458 \text{ gallons/sample} \times \frac{1 \text{ pulse}}{1,000 \text{ gallons}} = 36.458 \text{ pulses/sample}$$

Therefore, the value for **INTV** = \_ \_ \_ \_ **CNTS** is 36.

### Flow Proportional Sampling, External—Using 4–20 mA Signal Converted to Pulses, Flow Signal Interface

The Flow Signal Interface (Cat. No. 2020) is an optional 4–20 mA interface that converts 4–20 mA current signals (from a flow meter) to 12 V dc pulses.

At 20 mA, the interface transmits ten 12-volt pulses per minute. As the current signal decreases, the 12 V pulses decrease proportionally. Typically, users collect a certain number of samples over a given period of time when sampling in proportion to the flow rate.

To calculate the number of 12 V dc output pulses between samples, determine the total number of samples (represented by  $n$  in the following examples) that you want to collect, and the period of time over which you want to collect them. Use the three-step method presented below to determine the “Total Count” value that you will enter while programming the Setup section of the sampler.

1. Calculate  $Q$ , where  $Q$  is the average flow rate (during the sampling program) divided by the maximum flow rate. (The maximum flow rate corresponds to the 20 mA output of the flow meter.)
2. Calculate  $t$ , where  $t$  is defined as  $a/n$ ;  $n$  is the total number of samples collected over a given period of time; and  $a$  represents time in minutes, over which  $n$  samples are collected.
3. Multiply  $Q \times t$ . Enter the result in the programming step:  
**INTV** = \_ \_ \_ \_ **CNTS**.

**Note:** The product of  $Q \times t$  is not necessarily a whole number. You must round off the result to the nearest whole number.

Use the following examples to help you determine the value that you need to enter when programming for sampling based on counts.

### Example 1

You want to collect 24 samples over a 24-hour period on a 4–20 mA flow proportional basis.

Average Flow Rate = 3.5 mgd (average flow rate over the 24-hour period)

Maximum Flow Rate = 10 mgd

a = 1440 minutes

1. Calculate  $Q$ .

$$Q = \frac{\text{Average Flow Rate}}{\text{Maximum Flow Rate}} = \frac{3.5 \text{ mgd}}{10 \text{ mgd}} = 0.35 \text{ mgd}$$

2. Calculate  $t$ .

$$t = \frac{a}{n} = \frac{1440 \text{ min}}{24 \text{ samples}} = 60 \text{ min/sample}$$

3. Multiply  $Q \times t$ .

$$0.35 \text{ mgd} \times 60 \text{ min/sample} = 21$$

Therefore, the value entered for **INTV** = \_\_\_\_\_ **CNTS** is 21.

### Example 2

You want to collect 48 samples over a 24-hour period on a 4–20 mA flow proportional basis.

Average Flow Rate = 1.75 mgd (average flow rate over the 24-hour period)

Maximum Flow Rate = 3 mgd

a = 1440 minutes

1. Calculate  $Q$ .

$$Q = \frac{\text{Average Flow Rate}}{\text{Maximum Flow Rate}} = \frac{1.75 \text{ mgd}}{3 \text{ mgd}} = 0.583 \text{ mgd}$$

2. Calculate  $t$ .

$$t = \frac{a}{n} = \frac{1440 \text{ min}}{48 \text{ samples}} = 30 \text{ min/sample}$$

3. Multiply  $Q \times t$ .

$$0.583 \text{ mgd} \times 30 \text{ min/sample} = 17.5$$

Therefore, the value entered for **INTV** = \_\_\_\_\_ **CNTS** is 18.

### Example 3

You want to collect 96 samples over a 24-hour period on a 4–20 mA flow proportional basis.

Average Flow Rate = 0.52 mgd (average flow rate over the 24-hour period)

Maximum Flow Rate = 2 mgd

a = 1440 minutes

1. Calculate  $Q$ .

$$Q = \frac{\text{Average Flow Rate}}{\text{Maximum Flow Rate}} = \frac{0.52 \text{ mgd}}{2.0 \text{ mgd}} = 0.26 \text{ mgd}$$

2. Calculate  $t$ .

$$t = \frac{a}{n} = \frac{1440 \text{ min}}{96 \text{ samples}} = 15 \text{ min/sample}$$

3. Multiply  $Q \times t$ .

$$0.26 \text{ mgd} \times 15 \text{ min/sample} = 3.9$$

Therefore, the value entered for INTV = \_\_\_\_\_ CNTS is 4.

#### Example 4

You want to collect 32 samples over an 8-hour period.

Average Flow Rate = 70 gpm (average flow rate over the 8-hour period)

Maximum Flow Rate = 210 gpm

$a = 480$  minutes

1. Calculate  $Q$ .

$$Q = \frac{\text{Average Flow Rate}}{\text{Maximum Flow Rate}} = \frac{70 \text{ gpm}}{210 \text{ gpm}} = 0.33 \text{ gpm}$$

2. Calculate  $t$ .

$$t = \frac{a}{n} = \frac{480 \text{ min}}{32 \text{ samples}} = 15 \text{ min/sample}$$

3. Multiply  $Q \times t$ .

$$0.33 \text{ mgd} \times 15 \text{ min/sample} = 4.9$$

Therefore, the value entered for INTV = \_\_\_\_\_ CNTS is 5.

#### Example 5

It is desired to collect 30 samples over a 2-day period.

Average Flow Rate = 0.25 cfs (average flow rate over the 48-hour period)

Maximum Flow Rate = 1 cfs

$a = 2,880$  minutes

1. Calculate  $Q$ .

$$Q = \frac{\text{Average Flow Rate}}{\text{Maximum Flow Rate}} = \frac{0.25 \text{ cfs}}{1 \text{ cfs}} = 0.25 \text{ cfs}$$

2. Calculate  $t$ .

$$t = \frac{a}{n} = \frac{2,880 \text{ min}}{30 \text{ samples}} = 96 \text{ min/sample}$$

3. Multiply  $Q \times t$ .

$$0.25 \text{ cfs} \times 96 \text{ min/sample} = 24$$

Therefore, the value entered for INTV = \_\_\_\_\_ CNTS is 24.

You will notice from the previous five examples that the average and maximum flow rate can be expressed in any units, i.e. mgd, gpm, cfs, etc. However, express the average and maximum flow rate in the **same units** for any given situation.





**DANGER**

*Only qualified personnel should conduct the installation tasks described in this section of the manual*

## 5.1 Cleaning the Sampler

### 5.1.1 Cleaning the Sampler Housing

The interior and exterior sampler housing may be cleaned with a damp sponge and mild detergent. Do not use abrasive cleaners.

### 5.1.2 Cleaning the Sample Bottles

Clean the bottles using a brush and water with mild detergent, followed by a fresh water rinse and a diluted water rinse. Glass bottles may also be autoclaved.

### 5.1.3 Cleaning the Intake Tubing and Pump Tubing

Clean the tubing by pumping water with mild detergent or other cleaning solution through the tubing, using the peristaltic pump in Manual Pump Mode. Press the **MANUAL MODE** soft key.

### 5.1.4 No Lubrication Required

The 900 Composite Sampler does not require routine lubrication. Do not lubricate the pump tube with petroleum jelly, silicone grease, oil, or any other lubricant, as this will substantially reduce the life of the pump tube and roller assembly.

## 5.2 Pump Tubing Maintenance

## 5.3 Upgrades, Repairs, General Maintenance

## 5.4 Electrostatic Discharge (ESD) Considerations

## 5.5 Internal Maintenance Items

The following item requires access to the inside of the case for repairs:

- Internal desiccant module
- RAM memory battery

## 5.6 Removing and Opening the Controller

**CAUTION**

*Always power the unit OFF and then disconnect all cables from the 900 Composite sampler before removing the controller.*

To remove the controller from the controller center section:

1. Turn the unit off by pressing the **OFF** key.
2. Disconnect and remove all cables to the controller housing, including the distributor/full bottle shutoff cable.
3. Disconnect all tubing.

4. Place the controller, face down, on a cloth-covered workbench to prevent scratching the front panel.
5. Inside the Center Section, remove the four screws that fasten the Controller.
6. Lift the Center Section off the controller.
7. Remove the 17 screws from around the perimeter of the controller back panel.
8. Carefully pull open the bottom panel and let the attached connectors swing out of the way.
9. If necessary for the repair being performed, unplug the appropriate connectors. Always note each connector location before unplugging anything. **Re-installing a plug into the wrong connector can cause extensive damage.**

**Note:** The front panel gasket has a light coating of grease to help assure a watertight seal. Do not contaminate the grease or gasket area with dirt or debris during servicing. Always replace the gasket if it is damaged or missing. Never reassemble the case without the gasket properly installed.

### 5.7 Re-installing the Bottom Panel

**Note:** Always follow the procedure below when re-installing the 900 bottom panel. Improper panel installation may result in damage to the instrument.

1. Hand tighten each nut until it makes contact with the panel.
2. Tighten the nuts in sequence shown in [Figure 9](#) to 5 in.-lb (0.56 N-m).
3. Repeat the tightening procedure in the same sequence to 10 in.-lb (1.13 N-m).

**Figure 9** Tightening the Nuts on the Bottom Panel

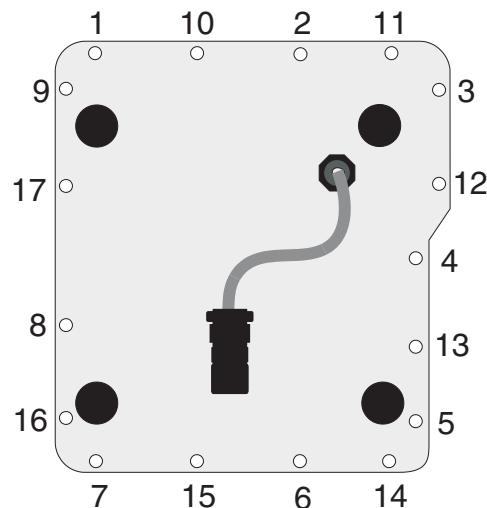

## 5.8 Internal Desiccant Module

The Internal Desiccant Module (Cat. No. 787) consists of a moisture-absorbent material inside a poly bag. If the humidity indicator on the front panel turns pink, replace the module and the back panel perimeter gasket. The desiccant module is located under the CPU board.

**Note:** The desiccant module cannot be recharged by heating. Do not attempt to bake the desiccant module in an oven to remove the moisture as this could be a fire hazard.

## 5.9 Circuit Board Identification

Figure 10 shows the 900 Composite Sampler circuit board, including:

- Placement of all connectors
- EPROM location
- Lithium Memory Battery
- Desiccant Module installation

Figure 10 Circuit Board Description

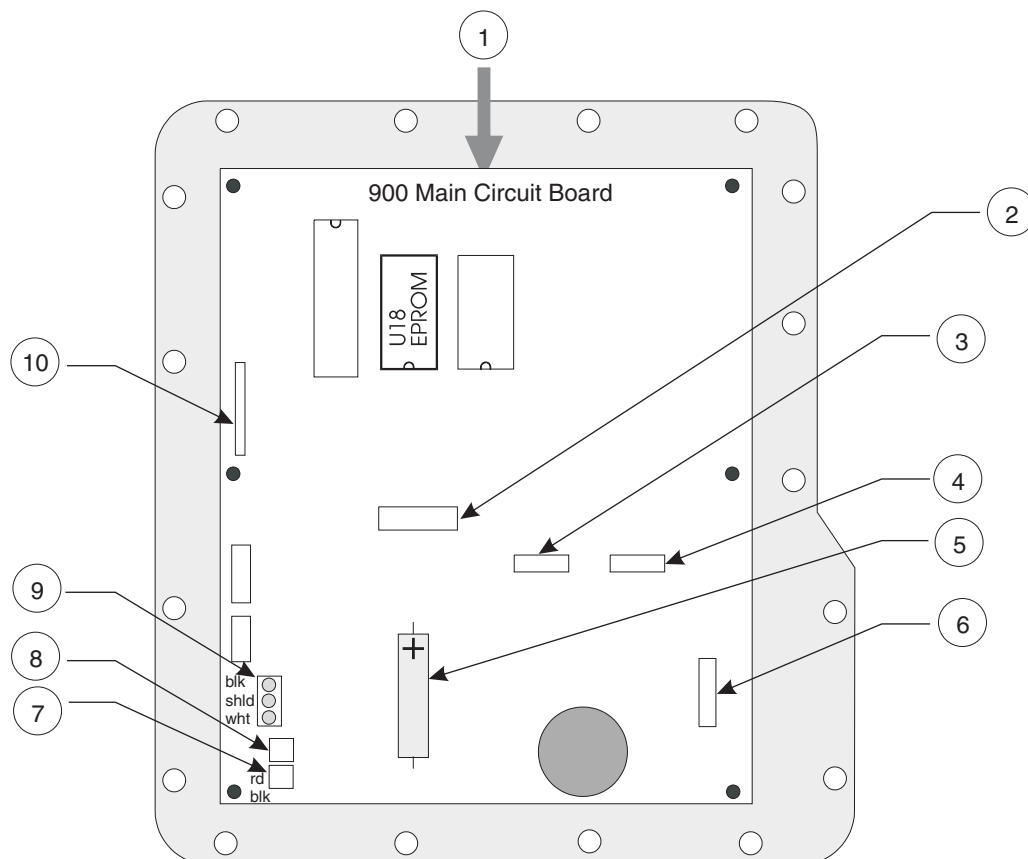

## Section 5

---

1. Desiccant module slides under circuit board	6. J5 Distributor/Full Bottle Shut-off
2. J8 LCD Display	7. J2 12 V dc
3. J6 Auxiliary	8. J3 Fuse
4. J1 Liquid Sensor	9. J4 Motor
5. Lithium Memory Battery	10. J9 Keypad

### 5.10 Motor/Gear Box

The motor/gear box requires no regular maintenance. The special formulation gears are self lubricating and require no oil or grease.

### 5.11 Internal Case Humidity Indicator

After replacing the desiccant module and re-sealing the case, the Internal Case Humidity indicator disc (Cat. No. 2660) should return to its original blue color. Replace the indicator disc if it fails to return to blue after replacing the desiccant module. To replace the indicator disc, remove the bottom panel that is held in place by a small clip and screw.

### 5.12 Internal Case Humidity Indicator

The humidity indicator is located on the left front side of the controller. If the humidity indicator is blue, the desiccant is dry. If the indicator turns pink or white, inspect the electronics housing for seal failure and replace the desiccant module.

### 5.13 Memory Battery

Random Access Memory (RAM) is a very reliable data storage medium for microprocessor applications. However, RAM requires power at all times. If power is removed, the data stored in the RAM chip is lost. Therefore, you cannot power the RAM chips from the 900 Composite Sampler power supply because you would lose data and program settings every time you unplugged the power cord. A separate battery located inside the sampler controller is provided to power the RAM chips and the real-time clock. The memory battery keeps the program entries and logged sample data alive inside the RAM memory when the main power fails or is removed for transport or replacement.

The 900 Composite Sampler memory battery consists of a 1.5 V dc Lithium cell. The battery is soldered to the main circuit board.

Should the memory battery voltage fall too low to properly maintain the program settings, a warning: **MEMORY POWER LOW** will alert you to replace the battery. The 900 Composite Sampler utilizes a very small amount of energy from the memory battery during normal operation. The service life of the batteries in this application is typically five years.

# Section 6 Contact Information for U.S.A. & Outside Europe

---

## Ordering Information for the U.S.A.

**By Telephone:**  
(800) 635-4567

**By Fax:**  
(970) 461-3915

**Ordering information by E-mail:**  
orders@hach.com

**By Mail:**  
Hach Company  
P.O. Box 389  
Loveland, Colorado 80539-0389  
U.S.A

### Information Required

- Hach account number (if available)
- Your name and phone number
- Purchase order number
- Brief description or model number
- Billing address
- Shipping address
- Catalog number
- Quantity

## Ordering Information for Outside the U.S.A. and Europe

Hach Company maintains a worldwide network of dealers and distributors. To locate the representative nearest you, send E-mail to intl@hach.com or visit [www.hach.com](http://www.hach.com).

## Technical Support

Technical and Customer Service Department personnel are eager to answer questions about our products and their use. In the U.S.A., call 1-800-635-1230. Outside the U.S.A. and Europe, send E-mail to intl@hach.com.

## Repair Service

Authorization must be obtained from Hach Company before sending any items for repair. Please contact the Hach Company Service Center serving your location.

Hach Company  
P.O. Box 389  
Loveland, Colorado, 80539-0389 U.S.A.

Telephone: 1-800-635-1230 or (970) 669-3050  
Fax: (970) 669-2932

## Section 7 Contact Information for Europe

---

For technical support, repair service, and ordering information please refer to the contact information below for your specific country. For additional information, visit [www.hach-lange.com](http://www.hach-lange.com).

### **Austria**

Dr. Bruno Lange Ges. MBH  
Industriestraße 12  
A - 3200 Obergrafendorf  
Tel. +43 (0)27 47 74 12  
Fax +43 (0)27 47 42 18  
[info@hach-lange.at](mailto:info@hach-lange.at)

### **Belgium**

Dr. Lange  
Motstraat 54  
B-2800 Mechelen  
Tel. +32 (0)15 42 35 00  
Fax +32 (0)15 41 61 20  
[info@hach-lange.be](mailto:info@hach-lange.be)

### **Denmark**

Dr. Lange Danmark A/S  
Jernhoolmen 34-40  
DK-2650 Hvidovre  
Tel. +45 (0)36 77 29 11  
Fax +45 (0)36 77 49 11  
[info@hach-lange.dk](mailto:info@hach-lange.dk)

### **France**

Hach Lange  
Hach SAS  
33 Rue du Ballon  
F-93165 Noisy Le Grand  
Tel. +33 (0)1 48 15 80 80  
Fax +33 (0)1 48 15 80 00  
[info@hach-lange.fr](mailto:info@hach-lange.fr)

### **Germany**

Dr. Bruno Lange GmbH  
& CO. KG  
Willstätterstr. 11  
D-40549 Düsseldorf  
Tel. +49 (0)2 11 52 88-0  
Fax +49 (0)2 11 52 88-143  
[info@hach-lange.de](mailto:info@hach-lange.de)

### **Great Britain**

Hach Lange LTD  
Lennox Road  
Basingstoke  
Hampshire, RG22 4AP  
Tel. +44 (0)12 56 33 34 03  
Fax +44 (0)12 56 33 07 24  
[info@hach-lange.co.uk](mailto:info@hach-lange.co.uk)

### **Italy**

Dr. Bruno Lange s.r.l.  
Via Riccione, 14  
I-20156 Milano  
Tel. +39 02 39 23 14-1  
Fax +33 02 39 23 14-39  
[info@hach-lange.it](mailto:info@hach-lange.it)

### **Poland**

Hach Lange sp.zo.o.  
ul. Opolska 143 a  
PL-52-013 Wroclaw  
Tel. +48 71 3 42 10 -81  
Fax +48 71 3 42 10-79  
[info@hach-lange.pl](mailto:info@hach-lange.pl)

### **The Netherlands**

Dr. Lange Nederland B.V.  
Laan an Westroijen 2a  
NL-4003 AZ Tiel  
Tel. +31 (0) 3 44 63 11 30  
Fax +31 (0) 3 44 63 11 50  
[info@hach-lange.nl](mailto:info@hach-lange.nl)

### **Spain/Portugal**

Hach Lange S.L.U.  
c/ Araba, 45. Apdo. 220  
E-20800 Zarauz/Guipúzcoa  
Tel. +34 9 43 89 43 79  
Fax +34 9 43 13 02 41  
[info@hach-lange.es](mailto:info@hach-lange.es)

### **Sweden**

Hach Lange AB  
Vinhundsvägen 159A  
S-128 62 Sködal  
Tel. +46 (0)8 7 98 05 00  
Fax +46 (0)8 7 98 05 03  
[info@hach-lange.se](mailto:info@hach-lange.se)

### **Switzerland**

Dr. Bruno Lange AG  
Juchstrasse 1  
CH-8604 Hegnau  
Tel. +41(0)1 9 45 66 10  
Fax +41(0)1 9 45 66 76  
[info@hach-lange.ch](mailto:info@hach-lange.ch)

## Section 8 Limited Warranty

---

Hach Company warrants its products to the original purchaser against any defects that are due to faulty material or workmanship for a period of \*one year\* from date of shipment unless otherwise noted in the product manual.

The sc100 Controller is warranted for two years from the date of shipment.

In the event that a defect is discovered during the warranty period, Hach Company agrees that, at its option, it will repair or replace the defective product or refund the purchase price, excluding original shipping and handling charges. Any product repaired or replaced under this warranty will be warranted only for the remainder of the original product warranty period.

This warranty does not apply to consumable products such as chemical reagents; or consumable components of a product, such as, but not limited to, lamps and tubing.

Contact Hach Company or your distributor to initiate warranty support. Products may not be returned without authorization from Hach Company.

### Limitations

This warranty does not cover:

- Damage caused by acts of God, natural disaster, labor unrest, acts of war (declared or undeclared), terrorism, civil strife or acts of any governmental jurisdiction
- Damage caused by misuse, neglect, accident or improper application or installation
- Damage caused by any repair or attempted repair not authorized by Hach Company
- Any product not used in accordance with the instructions furnished by Hach Company
- Freight charges to return merchandise to Hach Company
- Freight charges on expedited or express shipment of warranted parts or product
- Travel fees associated with on-site warranty repair

This warranty contains the sole express warranty made by Hach Company in connection with its products. All implied warranties, including without limitation, the warranties of merchantability and fitness for a particular purpose, are expressly disclaimed.

Some states within the United States do not allow the disclaimer of implied warranties and if this is true in your state the above limitation may not apply to you. This warranty gives you specific rights, and you may also have other rights that vary from state to state.

This warranty constitutes the final, complete, and exclusive statement of warranty terms and no person is authorized to make any other warranties or representations on behalf of Hach Company.

### Limitation of Remedies

The remedies of repair, replacement or refund of purchase price as stated above are the exclusive remedies for the breach of this warranty. On the basis of strict liability or under any other legal theory, in no event shall Hach Company be liable for any incidental or consequential damages of any kind for breach of warranty or negligence.





# Section 9

# Parts and Accessories

Description	Part Number
3-way Splitter Assembly .....	939
4–20 mA Interface, 10 ft Cable.....	2021
900 Series Peristaltic Pump Tubing, 15 ft .....	4600-15
900 Series Peristaltic Pump Tubing, 50 ft .....	4600-50
900 Series Peristaltic Pump Tube Insert .....	8888
All Weather Refrigerated Cabinet, 115 V ac .....	3548
Anchor Kit .....	8935
Cascade Sampling for 25-ft Cable .....	2817
Desiccant Bag (1 pillow).....	8849
Distributor Arm, 2-and 4-bottle Sampling .....	8846
Distributor Arm, 8-bottle Sampling .....	8845
Distributor Arm, 24-bottle Sampling .....	8844
Door Assembly .....	8702
Flow-thru Module .....	2471
Humidity Indicator .....	2660
Instrument Manual .....	8837
Lid Assembly with Latch.....	8968
Multi-purpose Full Cable, 10 ft .....	940
Multi-purpose Full Cable, 25 ft .....	540
Multi-purpose Half Cable, 10 ft.....	941
Multi-purpose Half Cable, 25 ft.....	541
O-ring, Main Seal .....	8606
Pump Tubing, 15 ft, For all distributors and 800 series peristaltic pumps .....	3866-15
Pump Tubing, 50 ft, For all distributors and 800 series peristaltic pumps .....	3866-50
Strainer, All 316 Stainless Steel, 6.0 in. long x 0.406 in. OD .....	2071
Strainer, All 316 Stainless Steel, 7.94 in. long, x 1.0 in. OD .....	2070
Strainer, Stainless Steel, 3.9 in. long x 0.406 in. OD .....	4652
Strainer, Teflon®/Stainless Steel, 5.5 in. long x 0.875 in. OD.....	926
Strainer, Teflon/Stainless Steel, 11.0 in. long x 0.875 in. OD.....	903
Synchronizing Sampling for 25-ft Cable .....	2818
Teflon-Lined Connection Kit .....	2186
Teflon-lined Tubing, 3/8 in., 10 ft .....	921
Teflon-lined Tubing, 3/8 in., 25 ft .....	922
Teflon-lined Tubing, 3/8 in., 100 ft .....	925
Vinyl Intake Tubing, 3/8 in., 25 ft .....	920
Vinyl Intake Tubing, 3/8 in., 100 ft .....	923
Vinyl Intake Tubing, 3/8 in., 500 ft .....	924

Sampler	Bottle Type	Part Number						
		Bottle	Full Bottle Shut-Off	Tube Support	Extension Tube	Bottle Tray/Positioner	Retainer	Distributor
Composite	2.5 gal. Glass	6559	8847	8838	3527	N/A	N/A	N/A
	3 gal. Poly.	1918	8847	8838	3527	N/A	N/A	N/A
	6 gal. Poly.	6494	8847	8838	N/A	N/A	N/A	N/A
Multiple Bottle	(24) 1 L Poly.	737	N/A	N/A	N/A	1511	1322	8841
	(24) 350 ml Glass	732	N/A	N/A	N/A	1511	1056	8841
	(8) 2.3 L Poly.	657	N/A	N/A	N/A	1511	1322	8842
	(8) 1.9 L Glass	1118	N/A	N/A	N/A	1511	1322	8842
	(4) 3 gal. Poly.	2315	N/A	N/A	N/A	N/A	N/A	8843
	(4) 2.5 gal. Glass	2317	N/A	N/A	N/A	N/A	N/A	8843
	(2) 2.5 gal. Glass	2318	N/A	N/A	N/A	N/A	N/A	8843
(2) 3 gal. Poly	2316	N/A	N/A	N/A	N/A	N/A	8843	



## Program Flow Chart

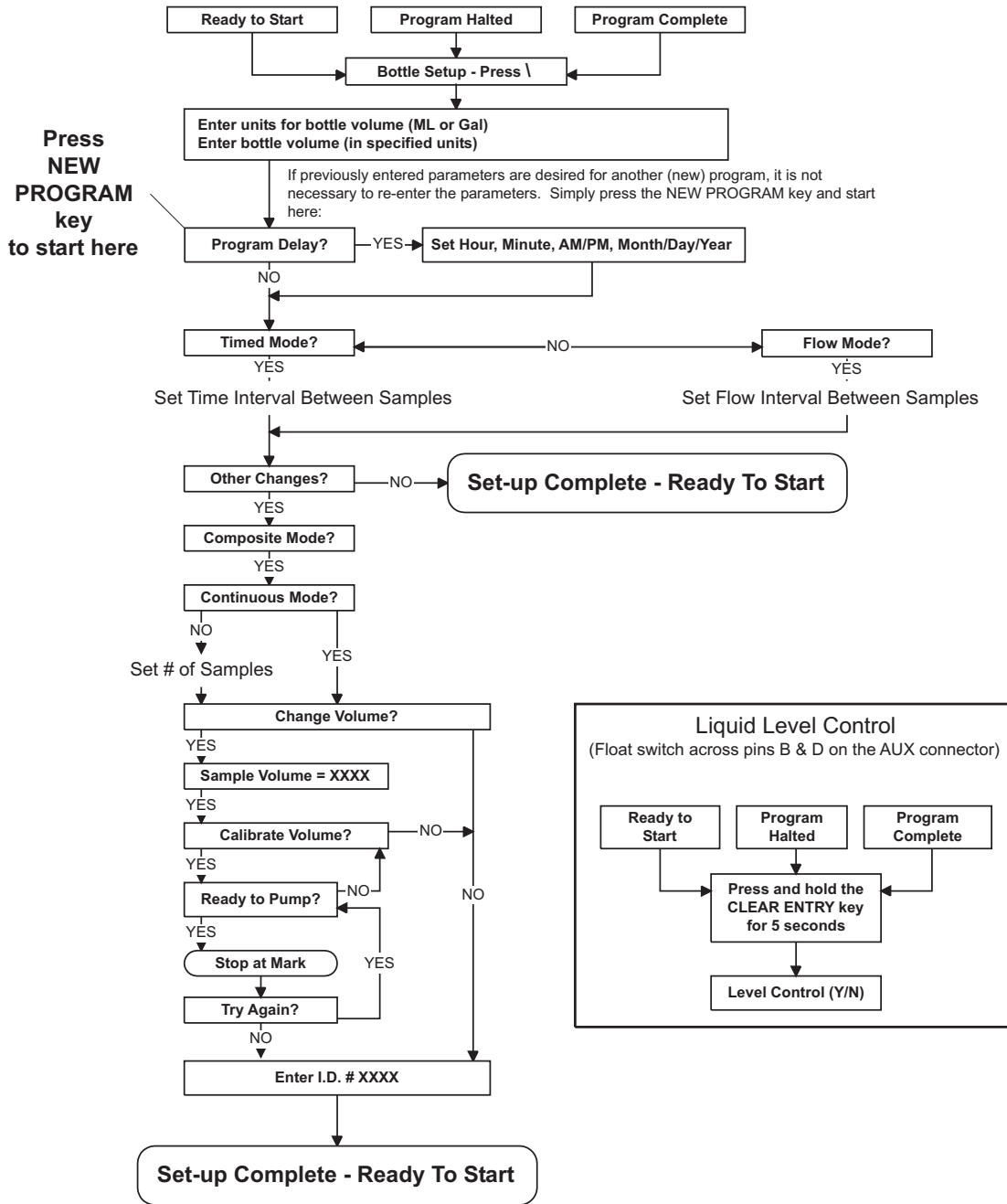



## Lead-Acid (Gel Cell) Batteries

Lead-acid batteries are designed to prevent electrolyte leakage from the terminals or case. The electrolyte is suspended in a gel, which ensures safe, efficient operation in any position. Gel cells are classified as “Non-Spillable” and meet all requirements of the International Air Transport Association.

### Maintenance

These lead-acid batteries are maintenance-free.

**Note:** The use of chargers other than those provided by manufacturer for use with these batteries is not recommended and may damage the battery or shorten its life.

### Charging

The lead-acid cells are designed to be fully charged in 22 to 24 hours using a lead-acid battery charger. Do not exceed 24 hours or you may damage or shorten the life of the battery. The charge rate is 500 mA dc.

### Temperature

At higher temperatures, the electrical capacity that can be taken out of a battery increases. At lower temperatures, the electrical capacity that can be taken out of a battery decreases. However, excessive heat destroys batteries. Avoid placing batteries near heat sources of any kind. To maximize battery life, operated the battery at an ambient temperature of 20 °C (70 °F). The permissible operating temperature range is -15 to 50 °C, however, use in the 5 to 35 °C temperature range is recommended.

### Storage

Store lead-acid batteries in a cool, dry place. Their low self-discharge rate and excellent charging characteristics permit storage for up to one year without loss of efficiency or appreciable deterioration of battery performance.

At room temperature the self-discharge rate of lead-acid batteries is approximately 3% of rated capacity per month. The self-discharge rate will vary as a function of ambient storage temperature.

Figure 1 on page 45 shows the storage self-discharge characteristics of lead-acid batteries at various ambient temperatures. Table 3 on page 46 shows recommended storage times for lead-acid batteries.

**Figure 1 Battery Discharge Characteristics**

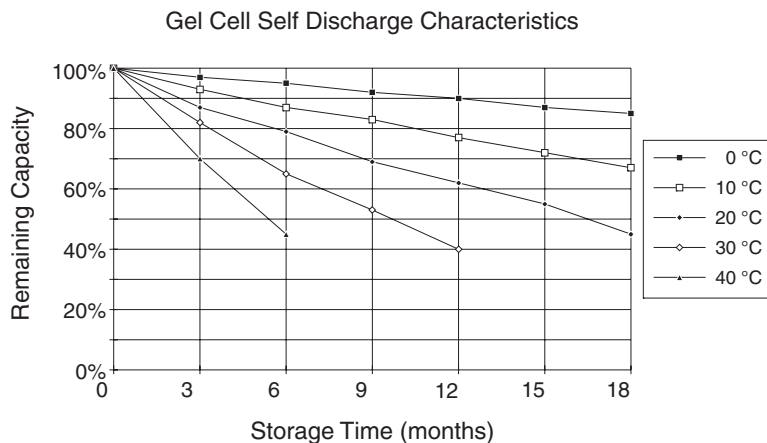

**Table 3 Lead-Acid Battery Storage Recommendations**

Storage Temperature	Maximum Recommended Storage Time
0 to 20 °C	12 months
21 to 30 °C	9 months
31 to 40 °C	5 months
41 to 50 °C	2.5 months

## Nickel-Cadmium Batteries

Nickel-cadmium batteries provide superior power capabilities when used at low temperatures. They also perform a higher number of charge/discharge cycles than lead-acid batteries.

### Maintenance

Nickel-cadmium cells are of a sealed construction. They contain no free electrolyte, and in most cases require no service or maintenance other than recharging.

### Charging

Charge new nickel-cadmium batteries prior to use due to their self-discharge rate.

Nickel-cadmium cells are designed to be fully charged using a nickel-cadmium battery charger within 14 to 16 hours. Do not exceed 16 hours or you may damage or shorten the life of the battery. The charge rate is 400 mA dc.

### Storage

At room temperature, the self discharge rate of nickel-cadmium batteries can be as high as 2% per day. When charged cells have been stored for a long period of time, or at an elevated temperature, a change starts to take place in the negative probe. The structure changes so that it is less reactive than a fresh cell. This structure will return to normal after one or two charge/discharge cycles. Batteries that have been stored for extended periods of time (longer than one week) should be fully charged prior to use.

Nickel-cadmium cells can be stored for extended periods of time, in either a charged or discharged condition, without significant degradation in their performance. However, after long storage periods, the battery pack may require a few charge/discharge cycles to restore its full capacity.

**Table 4 Nickel-Cadmium Battery Storage Recommendations**

Storage Temperature	Maximum Recommended Storage Time
20 to 30 °C	9 months
30 to 40 °C	5 months
over 40 °C	3 months

*Note: The use of chargers other than those provided by the manufacturer for use with these batteries is not recommended and may damage the battery or shorten its life.*

## Exploded View (1 of 6)

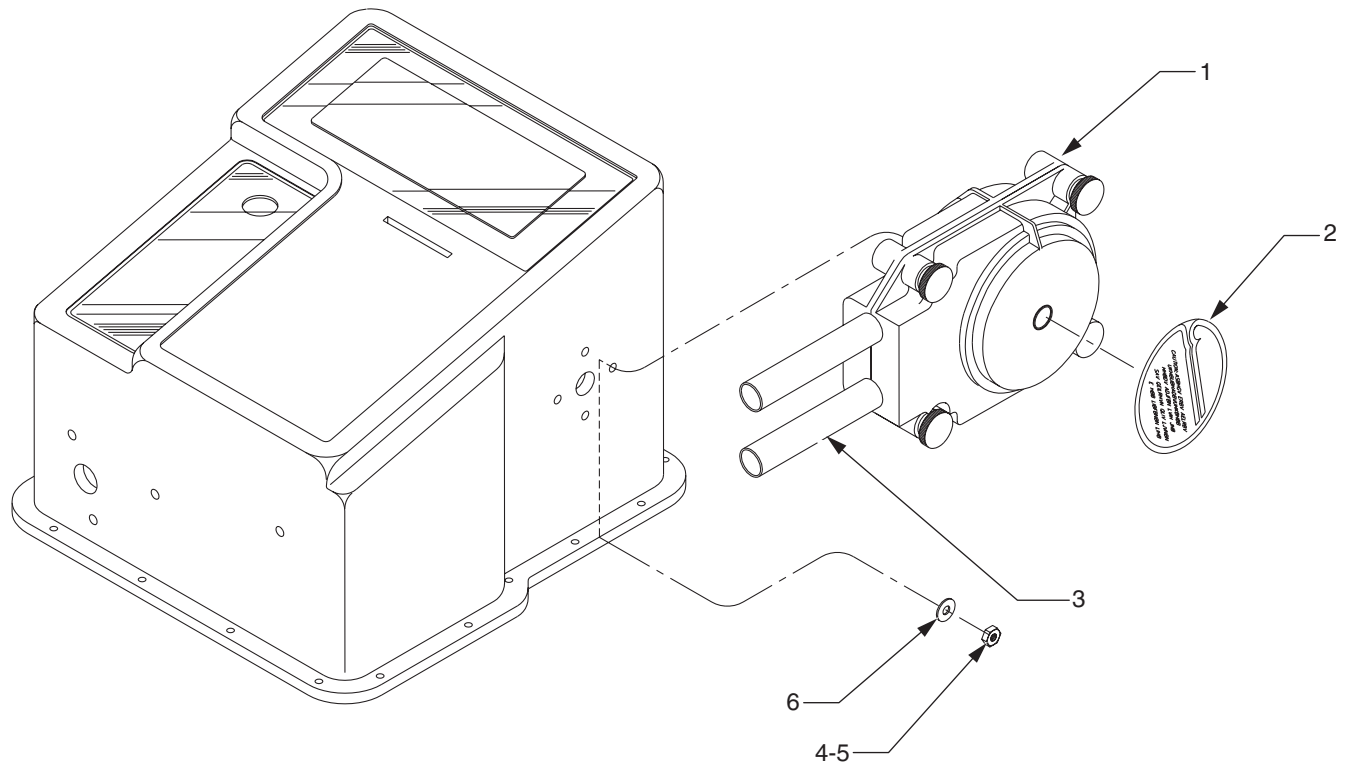

Item Number	Description	QTY	Part Number
1	Pump Assembly	1	1075
2	Overlay	1	906
3	Pump Tube Insert	1	2441
4	Hex Nut	4	SE 403
5	Threadlock	4	SE 957
6	Flat Washer	4	SE 400

## Exploded View (2 of 6)

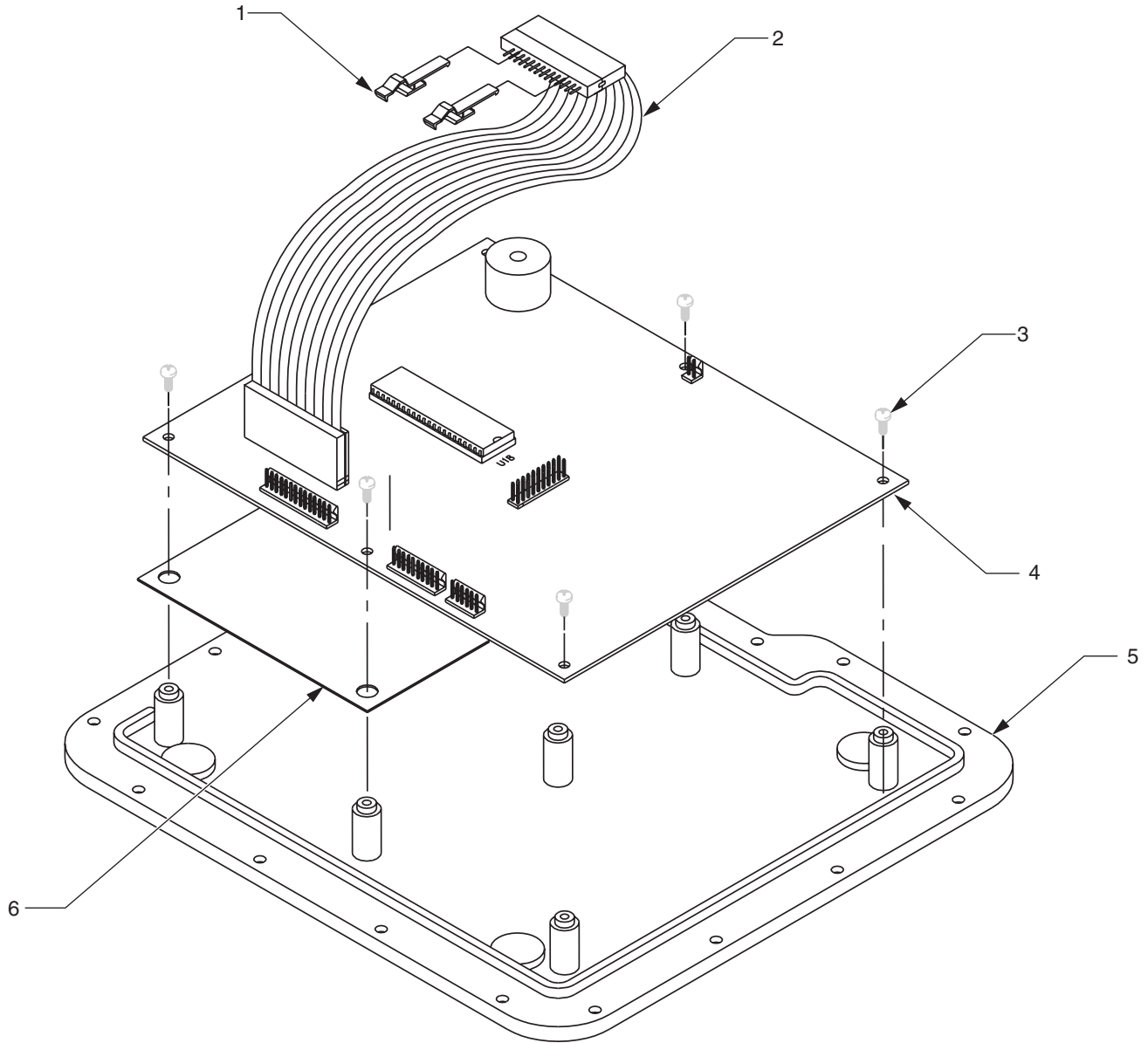

Item Number	Description	QTY	Part Number
1	Latch	1	2279
2	Keypad Cable Assembly	1	8586
3	Screw	6	SE 340
4	CPU PCB Assembly	1	8921
5	900 Controller Cover	1	8611
6	PCB Shield Plate	1	8624



Exploded View (3 of 6)

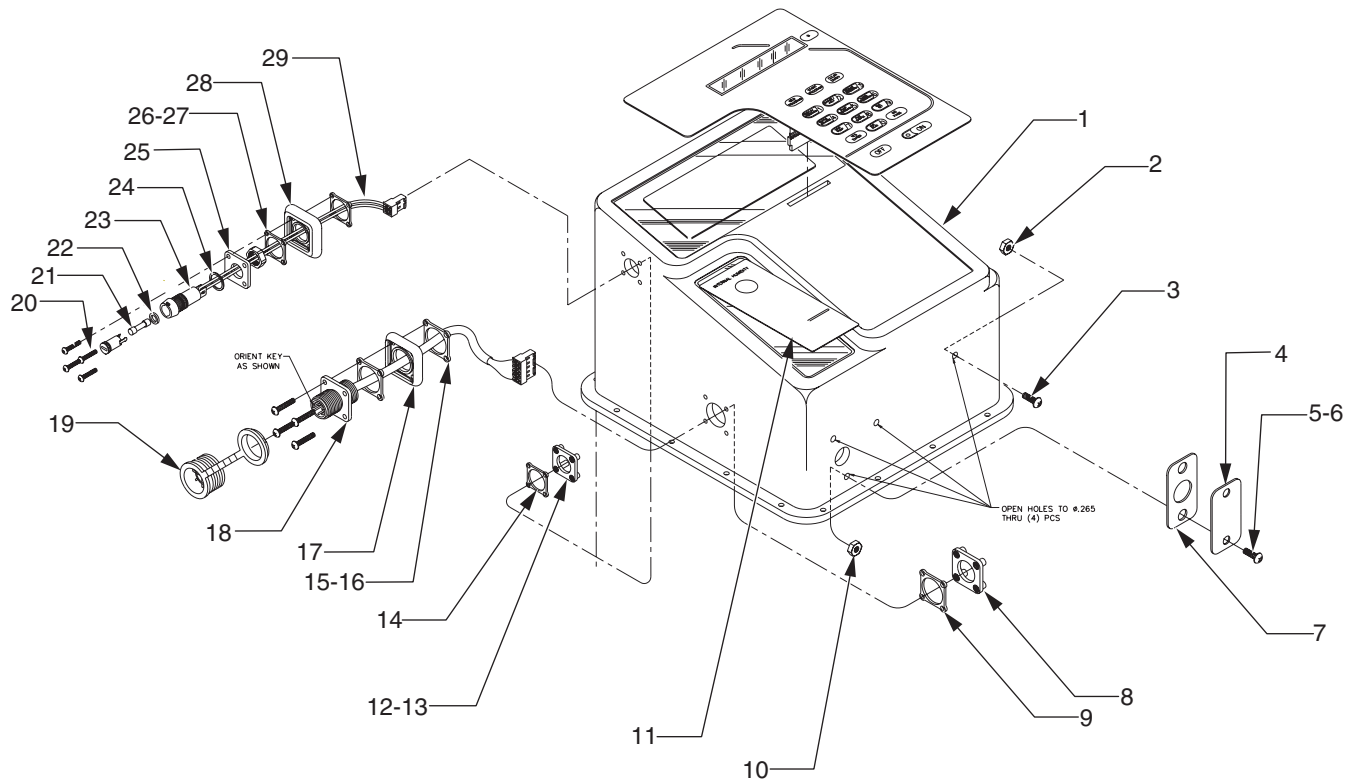

Item Number	Description	QTY	Part Number	Item Number	Description	QTY	Part Number
1	900 Controller Case	1	8619	16	O-ring Lubricant	1	SE 1048
2	Hex Nut	4	SE 701	17	Mounting Plate	1	2547
3	Screw/Threadlock (SE 957)	2	SE 747	18	Auxiliary Cable Assembly	1	8913
4	PCB Assembly	1	8538	19	Connector Cap	1	2859
5	Screw	2	SE 747	20	Screw	12	SE 229
6	Threadlock	2	SE 957	21	Slow Blow Fuse, 5A, 250 V	1	8753
7	Ultrasonic Sensor Gasket	1	8609	22	O-ring	1	3321
8	Retainer Plate	1	2548	23	Fuse Holder, 5 x 20 mm	1	3320
9	Retainer Plate Gasket	1	2550	24	O-ring	1	3319
10	Hex Nut	1	SE 701	25	Fuse Mounting Plate	1	8540
11	Humidity Indicator Overlay	1	4319	26	Mounting Plate Gasket	1	2556
12	Retainer Plate	1	2554	27	O-ring Lubricant	1	SE 1048
13	O-ring Lubricant	1	SE 1048	28	Mounting Plate	1	2555
14	Retainer Plate Gasket	1	2557	29	Fuse Holder Cable Assy.	1	3146
15	Mounting Plate	1	2549				

## Exploded View (4 of 6)

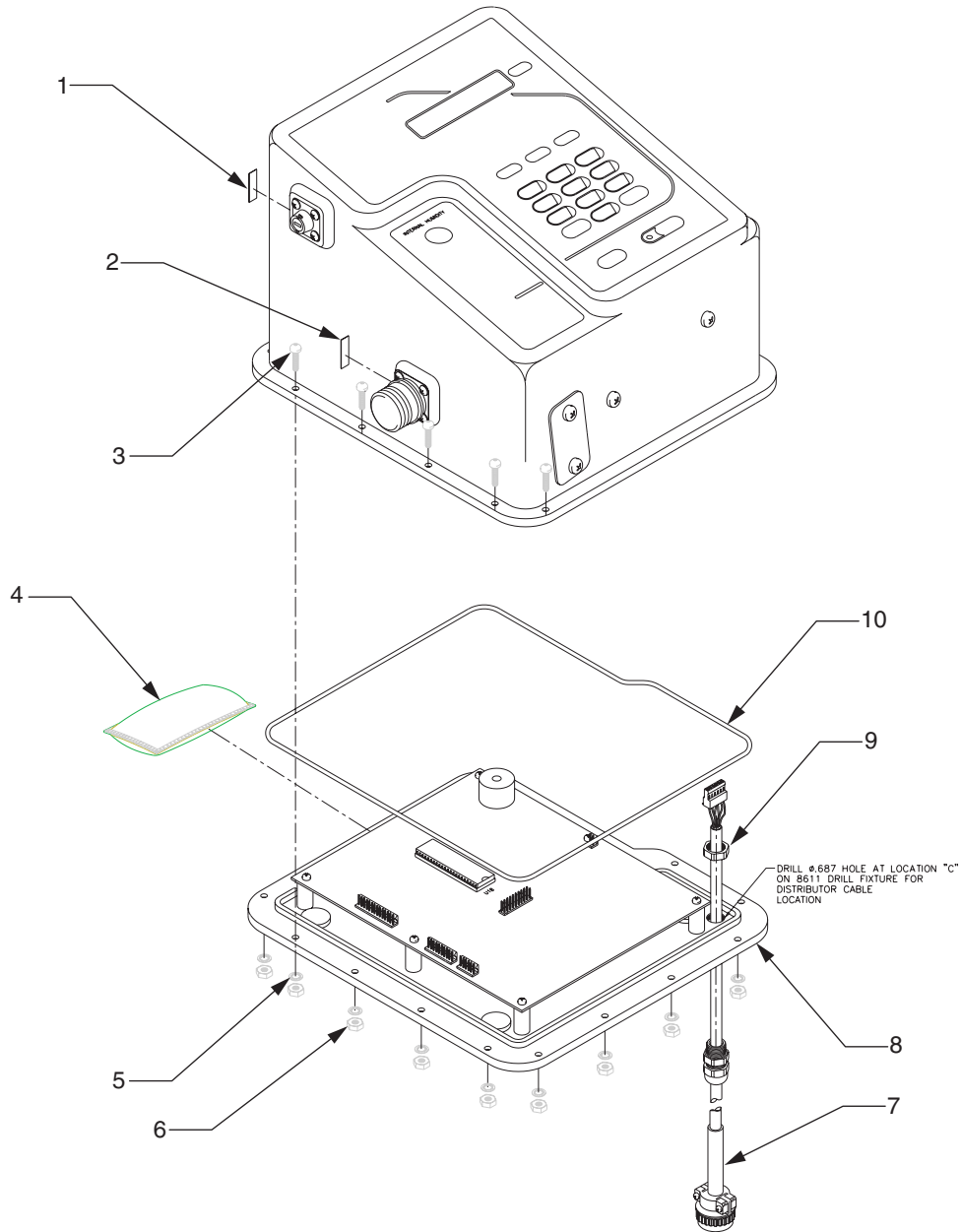

Item Number	Description	QTY	Part Number	Item Number	Description	QTY	Part Number
1	5 Amp Fuse Label	1	8537	6	Hex Nut (tighten to 16 in./lb)	17	SE 301
2	Overlay	1	8807	7	Distributor Cable Assembly	1	8539
3	Screw	1	SE 343	8	900 Controller Cover	1	8611
4	Desiccant Bag	1	8849	9	Lock Nut	1	8783
5	Lock Washer	17	SE 302	10	O-ring Main Seal	1	8606

Exploded View (5 of 6)

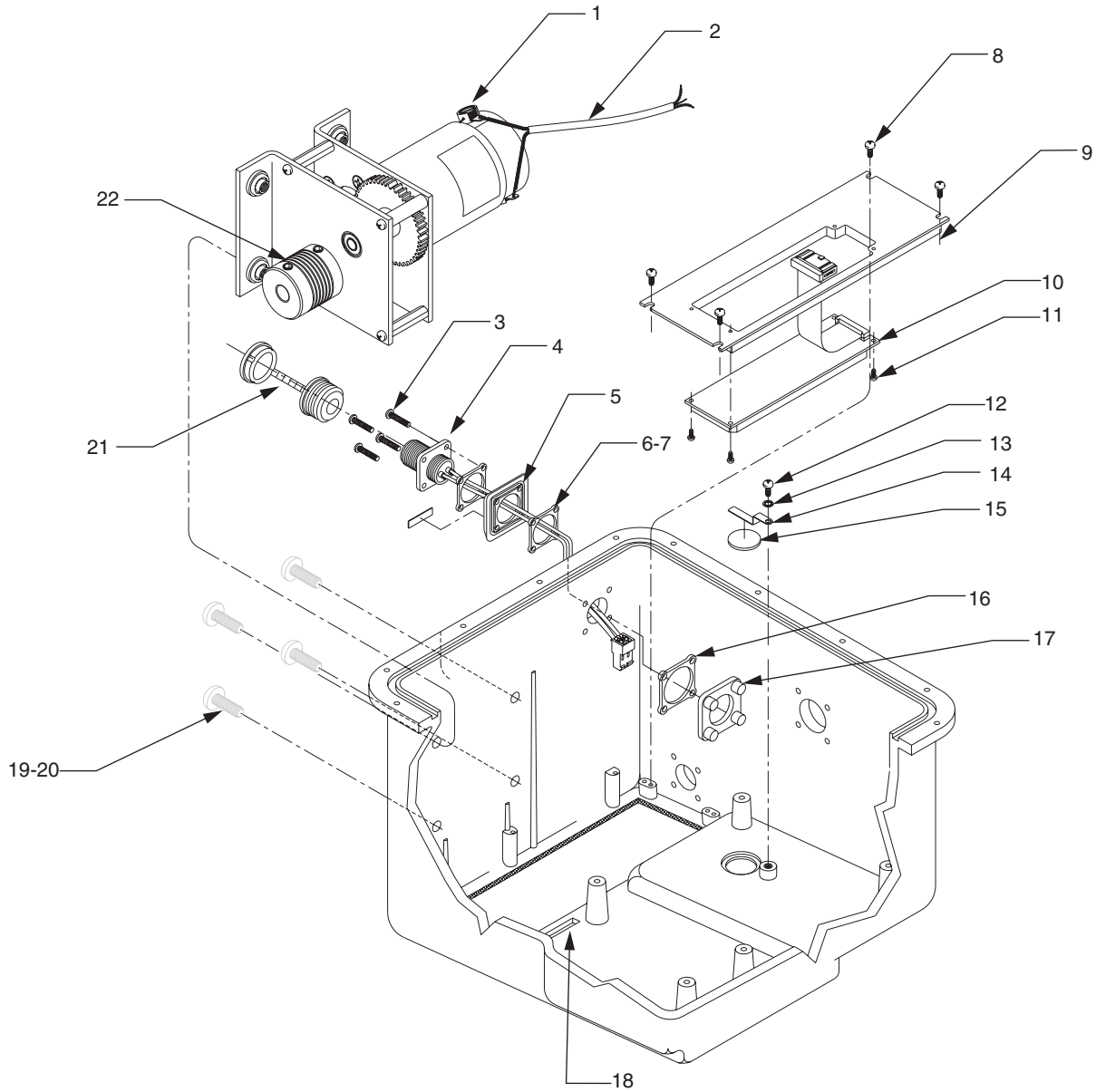

Item Number	Description	QTY	Part Number	Item Number	Description	QTY	Part Number
1	Gearbox Assembly	1	8910	12	Screw	1	SE 214
2	Motor Cable Assembly	1	8859	13	Lock Washer	1	SE 208
3	Screw	1	SE 229	14	Desiccant Card Bracket	1	2594
4	Internal Power Cable Assy.	1	8917	15	Humidity Indicator Card	1	2660
5	Connector Mounting Plate	1	2555	16	Retainer Plate Gasket	1	2557
6	Mounting Plate Gasket	1	2556	17	Retainer Plate	1	2554
7	O-ring Lubricant	1	SE 1048	18	Adhesive	1	SE 1062
8	Screw	4	SE 244	19	Screw	4	SE 738
9	Bracket	1	8898	20	Threadlock	4	SE 957
10	Display Assembly	1	8911	21	Connector Cap	1	2660
11	Screw	4	SE 105	22	Threadlock	1	SE 957

## Exploded View (6 of 6)

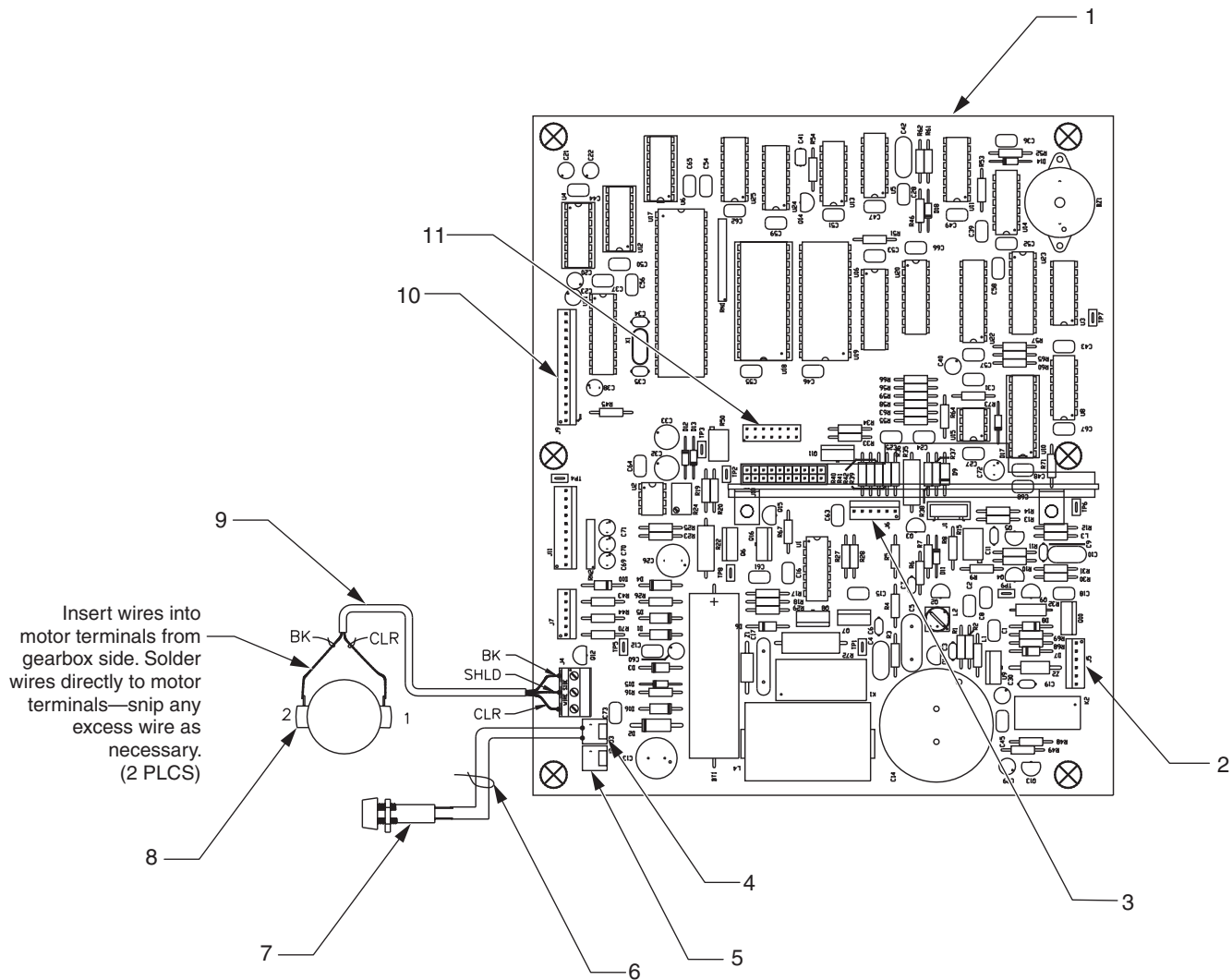

Item Number	Description	Part Number
1	CPU PCB Assembly	8921
2	Distributor (J5)	—
3	Auxiliary (J6)	—
4	Pin 2 (J3)	—
5	Power (J2)	—
6	Cable Assembly Fuse Holder	3146
7	Fuse Holder, 5 x 20 mm	3320
8	Gearbox Assembly	8910
9	Motor Cable Assembly	8859
10	Keypad (J9)	—