



MODULE SPECIFICATION

Version: 1.0

Model No.:ZGU36ESLSS

Part No.: 191D9618G001

HW Version: 1.1

FCC ID:ZKJ-BLEEC001

Manufacturer:iTON Technology Corp.

CONTENT

CONTENT.....	II
1.Summary.....	1
2.Functional Block Diagram	1
3.Module Hardware Characteristic.....	2
3.1 RF Specifications	2
3.2 Electrical Characteristics	4
4. Connector pin definitions.....	5
5. Module Size	6
5.1 Sample Picture	6
5.2 Mechanical Dimensions.....	6
6. FCC statements.....	7

1.Summary

The Module which use the Cypress® CYW20707UA2 that is a single-chip Bluetooth 4.2-compliant, stand-alone baseband processor with an integrated 2.4 GHz transceiver.

The Module is the optimal solution for embedded and IoT applications. Built-in firmware adheres to the Bluetooth Low Energy (BLE) profile.

Features:

- 1) Complies with Bluetooth Core Specification version 4.2 including BR/EDR/BLE
- 2) Supports Broadcom proprietary LE data rate up to 2 Mbps
- 3) BLE HID profile version 1.00 compliant
- 4) Bluetooth Device ID profile version 1.3 compliant
- 5) Supports Generic Access Profile (GAP)
- 6) Supports Adaptive Frequency Hopping (AFH)
- 7) Excellent receiver sensitivity

2.Functional Block Diagram

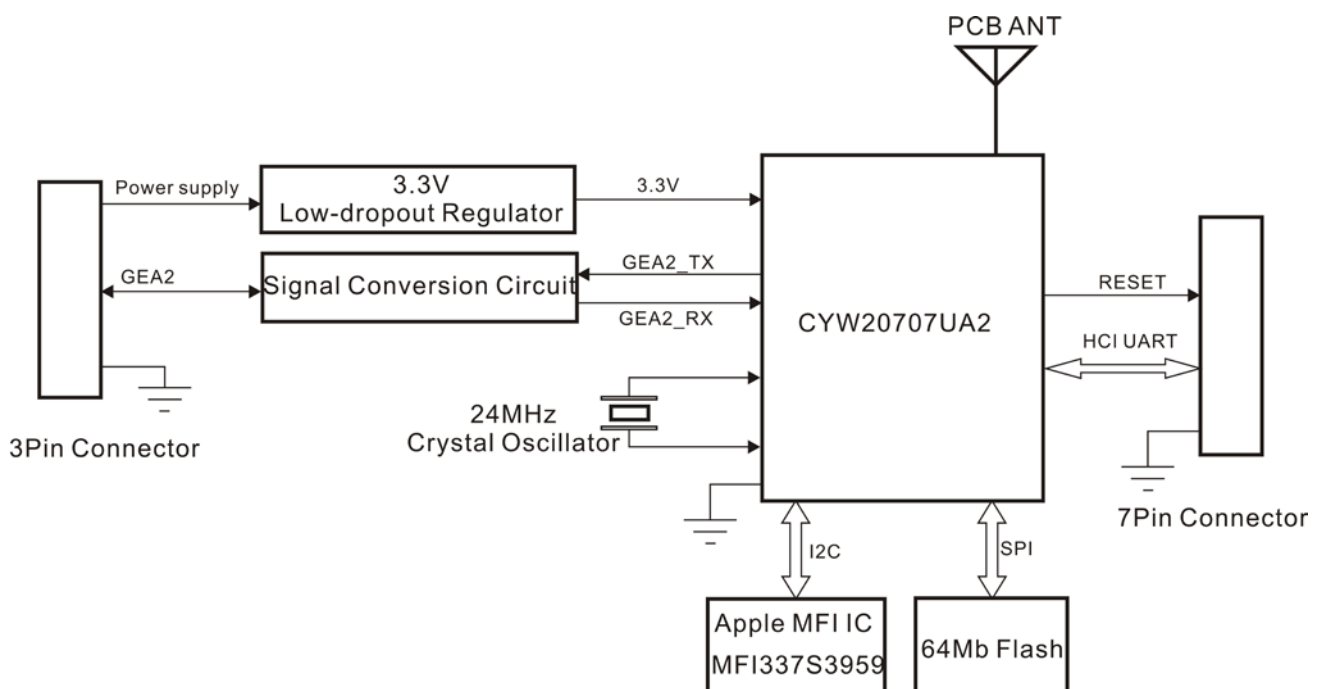

3.Module Hardware Characteristic

3.1 RF Specifications

1.Receiver RF Specifications

Parameter	Conditions	Minimum	Typical ¹	Maximum	Unit
General					
Frequency range	–	2402	–	2480	MHz
RX sensitivity ²	GFSK, 0.1% BER, 1 Mbps	–	–93.5	–	dBm
	LE GFSK, 0.1% BER, 1 Mbps	–	–96.5	–	dBm
	$\pi/4$ -DQPSK, 0.01% BER, 2 Mbps	–	–95.5	–	dBm
	8-DPSK, 0.01% BER, 3 Mbps	–	–89.5	–	dBm
Maximum input	GFSK, 1 Mbps	–	–	–20	dBm
Maximum input	$\pi/4$ -DQPSK, 8-DPSK, 2/3 Mbps	–	–	–20	dBm
Interference Performance					
C/I cochannel	GFSK, 0.1% BER	–	9.5	11	dB
C/I 1 MHz adjacent channel	GFSK, 0.1% BER	–	–5	0	dB
C/I 2 MHz adjacent channel	GFSK, 0.1% BER	–	–40	–30.0	dB
C/I \geq 3 MHz adjacent channel	GFSK, 0.1% BER	–	–49	–40.0	dB
C/I image channel	GFSK, 0.1% BER	–	–27	–9.0	dB
C/I 1 MHz adjacent to image channel	GFSK, 0.1% BER	–	–37	–20.0	dB
C/I cochannel	$\pi/4$ -DQPSK, 0.1% BER	–	11	13	dB
C/I 1 MHz adjacent channel	$\pi/4$ -DQPSK, 0.1% BER	–	–8	0	dB
C/I 2 MHz adjacent channel	$\pi/4$ -DQPSK, 0.1% BER	–	–40	–30.0	dB
C/I \geq 3 MHz adjacent channel	8-DPSK, 0.1% BER	–	–50	–40.0	dB
C/I image channel	$\pi/4$ -DQPSK, 0.1% BER	–	–27	–7.0	dB
C/I 1 MHz adjacent to image channel	$\pi/4$ -DQPSK, 0.1% BER	–	–40	–20.0	dB
C/I cochannel	8-DPSK, 0.1% BER	–	17	21	dB
C/I 1 MHz adjacent channel	8-DPSK, 0.1% BER	–	–5	5	dB
C/I 2 MHz adjacent channel	8-DPSK, 0.1% BER	–	–40	–25.0	dB
C/I \geq 3 MHz adjacent channel	8-DPSK, 0.1% BER	–	–47	–33.0	dB
C/I Image channel	8-DPSK, 0.1% BER	–	–20	0	dB
C/I 1 MHz adjacent to image channel	8-DPSK, 0.1% BER	–	–35	–13.0	dB
Out-of-Band Blocking Performance (CW)³					
30 MHz–2000 MHz	0.1% BER	–	–10.0	–	dBm
2000–2399 MHz	0.1% BER	–	–27	–	dBm
2498–3000 MHz	0.1% BER	–	–27	–	dBm
3000 MHz–12.75 GHz	0.1% BER	–	–10.0	–	dBm

Parameter	Conditions	Minimum	Typical ¹	Maximum	Unit
Out-of-Band Blocking Performance, Modulated Interferer					
776–764 MHz	CDMA	–	–10 ⁴	–	dBm
824–849 MHz	CDMA	–	–10 ⁴	–	dBm
1850–1910 MHz	CDMA	–	–23 ⁴	–	dBm
824–849 MHz	EDGE/GSM	–	–10 ⁴	–	dBm
880–915 MHz	EDGE/GSM	–	–10 ⁴	–	dBm
1710–1785 MHz	EDGE/GSM	–	–23 ⁴	–	dBm
1850–1910 MHz	EDGE/GSM	–	–23 ⁴	–	dBm
1850–1910 MHz	WCDMA	–	–23 ⁴	–	dBm
1920–1980 MHz	WCDMA	–	–23 ⁴	–	dBm
Intermodulation Performance⁵					
BT, Df = 5 MHz	–	–39.0	–	–	dBm
Spurious Emissions⁶					
30 MHz to 1 GHz	–	–	–	–62	dBm
1 GHz to 12.75 GHz	–	–	–	–47	dBm
65 MHz to 108 MHz	FM Rx	–	–147	–	dBm/Hz
746 MHz to 764 MHz	CDMA	–	–147	–	dBm/Hz
851–894 MHz	CDMA	–	–147	–	dBm/Hz
925–960 MHz	EDGE/GSM	–	–147	–	dBm/Hz
1805–1880 MHz	EDGE/GSM	–	–147	–	dBm/Hz
1930–1990 MHz	PCS	–	–147	–	dBm/Hz
2110–2170 MHz	WCDMA	–	–147	–	dBm/Hz
20707 GLONASS Band Spurious Emissions⁷					
Spurious Emissions	–	–	–118	–	dBm/Hz
Out-of-Band Noise Floor					
1570-1580MHz	GPS	–	–147	–	dBm/Hz
1592-1610MHz	GLONASS	–	–147	–	dBm/Hz

1. Typical operating conditions are 1.22V operating voltage and 25°C ambient temperature.
2. The receiver sensitivity is measured at BER of 0.1% on the device interface.
3. Meets this specification using a front-end bandpass filter.
4. Numbers are referred to the pin output with an external BPF filter.
5. f₀ = –64 dBm Bluetooth-modulated signal, f₁ = –39 dBm sine wave, f₂ = –39 dBm Bluetooth-modulated signal, f₀ = 2f₁ – f₂, and |f₂ – f₁| = n*1 MHz, where n is 3, 4, or 5. For the typical case, n = 4.
6. Includes baseband radiated emissions.
7. Max TX power (12dBm at chip out), Modulation is PRBS9, Modulation type is GFSK.

2. Transmitter RF Specifications

Parameter	Conditions	Minimum	Typical	Maximum	Unit
General					
Frequency range	–	2402	–	2480	MHz
Class1: GFSK Tx power ¹	–	–	12	–	dBm
Class1: EDR Tx power ²	–	–	9	–	dBm
Class 2: GFSK Tx power	–	–	2	–	dBm
Power control step	–	2	4	8	dB
Modulation Accuracy					
$\pi/4$ -DQPSK Frequency Stability	–	–10	–	10	kHz
$\pi/4$ -DQPSK RMS DEVM	–	–	–	20	%
$\pi/4$ -QPSK Peak DEVM	–	–	–	35	%
$\pi/4$ -DQPSK 99% DEVM	–	–	–	30	%
8-DPSK frequency stability	–	–10	–	10	kHz
8-DPSK RMS DEVM	–	–	–	13	%
8-DPSK Peak DEVM	–	–	–	25	%
8-DPSK 99% DEVM	–	–	–	20	%
In-Band Spurious Emissions					
1.0 MHz < M – N < 1.5 MHz	–	–	–	–26	dBc
1.5 MHz < M – N < 2.5 MHz	–	–	–	–20	dBm
M – N \geq 2.5 MHz	–	–	–	–40	dBm
Out-of-Band Spurious Emissions					
30 MHz to 1 GHz	–	–	–	–36.0 ³	dBm
1 GHz to 12.75 GHz	–	–	–	–30.0 ^{3, 4}	dBm
1.8 GHz to 1.9 GHz	–	–	–	–47.0	dBm
5.15 GHz to 5.3 GHz	–	–	–	–47.0	dBm

1. 12 dBm output for GFSK measured with PAVDD = 2.5V.
2. 9 dBm output for EDR measured with PAVDD = 2.5V.
3. Maximum value is the value required for Bluetooth qualification.
4. Meets this spec using a front-end band pass filter.

3. BLE RF Specifications

Parameter	Conditions	Minimum	Typical	Maximum	Unit
Frequency range	N/A	2402	–	2480	MHz
Rx sense ¹	GFSK, 0.1% BER, 1 Mbps	–	–96.5	–	dBm
Tx power ²	N/A	–	9	–	dBm
Mod Char: Delta F1 average	N/A	225	255	275	kHz
Mod Char: Delta F2 max ³	N/A	99.9	–	–	%
Mod Char: Ratio	N/A	0.8	0.95	–	%

1. Dirty Tx is Off.
2. The BLE Tx power can be increased to compensate for front-end losses such as BPF, diplexer, switch, etc. The output is capped at 12 dBm out. The BLE Tx power at the antenna port cannot exceed the 10 dBm EIRP specification limit.
3. At least 99.9% of all delta F2 max frequency values recorded over 10 packets must be greater than 185 kHz.

4. Antenna: PCB Antenna.

5. Antenna Gain: 1.43dBi

3.2 Electrical Characteristics

1. Operation temperature range: $-25^{\circ}\text{C} \sim +85^{\circ}\text{C}$
2. Storage temperature range: $-40^{\circ}\text{C} \sim +125^{\circ}\text{C}$

4. Connector pin definitions

7Pin connector (J101)model:TMM-107-01-F-S-SM

3Pin connector(J105) model:BM03B-XASS-TF

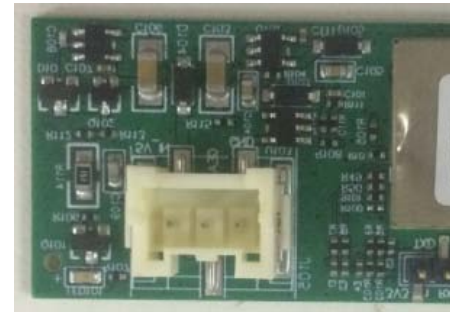

J101_1Pin

J105_1Pin

J101 connector pin definition

Pin	Signal	Description	Remark
1	3V3	Output voltage:3.3V typ	
2	TXD	20707 HCI UART_TX: UART transmit data	
3	RXD	20707 HCI UART_RX:UART receive data	
4	RST	20707 Reset :Active-low reset input	
5	RTS	20707 HCI UART_RTS: UART request to send output	
6	CTS	20707 HCI UART_CTS:UART clear to send input	
7	GND	Ground	

J105 connector pin definition

Pin	Signal	Description	Remark
1	5V_IN	Power supply Range:4V~6.5V(5V typ)	
2	GEA2	Communication signals	
3	GND	Ground	

5. Module Size

5.1 Sample Picture

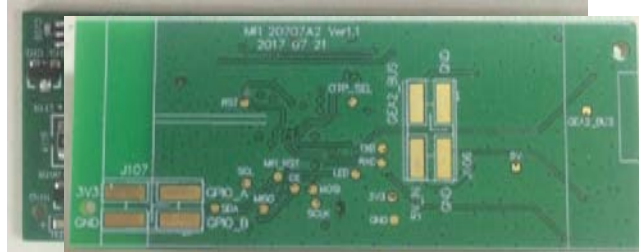

5.2 Mechanical Dimensions

Unit :mm
Tolerance: $\pm 0.15\text{mm}$

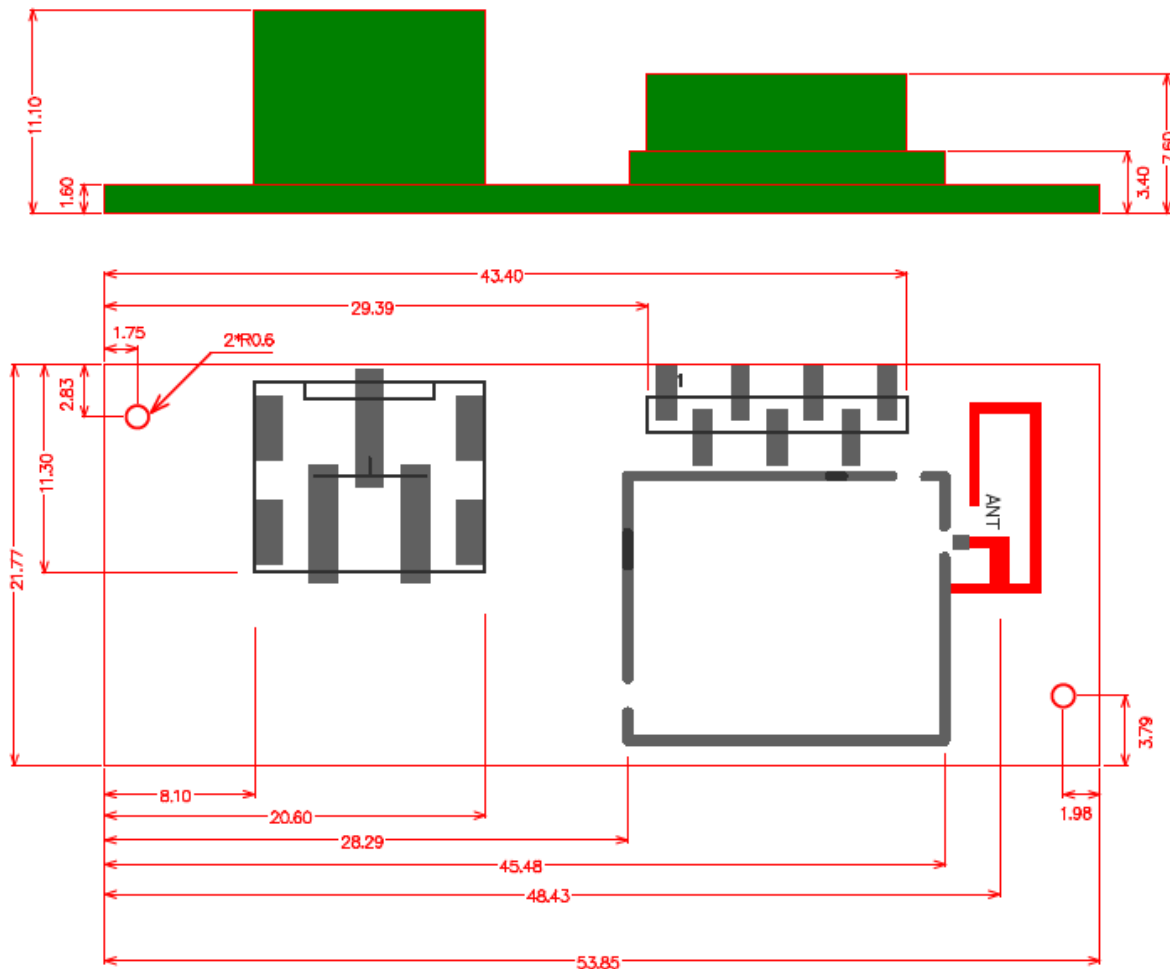

6.FCC statements:

This device complies with part 15 of the FCC rules. Operation is subject to the following two conditions: (1) this device may not cause harmful interference, and (2) this device must accept any interference received, including interference that may cause undesired operation.

NOTE: The manufacturer is not responsible for any radio or TV interference caused by unauthorized modifications or changes to this equipment. Such modifications or changes could void the user's authority to operate the equipment.

NOTE: This equipment has been tested and found to comply with the limits for a Class B digital device, pursuant to part 15 of the FCC Rules. These limits are designed to provide reasonable protection against harmful interference in a residential installation. This equipment generates uses and can radiate radio frequency energy and, if not installed and used in accordance with the instructions, may cause harmful interference to radio communications. However, there is no guarantee that interference will not occur in a particular installation. If this equipment does cause harmful interference to radio or television reception, which can be determined by turning the equipment off and on, the user is encouraged to try to correct the interference by one or more of the following measures:

- Reorient or relocate the receiving antenna.
- Increase the separation between the equipment and receiver.
- Connect the equipment into an outlet on a circuit different from that to which the receiver is connected.
- Consult the dealer or an experienced radio/TV technician for help.

The device has been evaluated to meet general RF exposure requirement, The device can be used in portable exposure condition without restriction

Federal Communication Commission (FCC) Radiation Exposure Statement

Power is so low that no RF exposure calculation is needed.

This device is intended only for OEM integrators under the following conditions:

- 1) The antenna must be installed such that 20 cm is maintained between the antenna and users, and
- 2) The transmitter module may not be co-located with any other transmitter or antenna. As long as two conditions above are met, further transmitter test will not be required. However, the OEM integrator is still responsible for testing their end-product for any additional compliance requirements required with this module installed. To ensure compliance with all non-transmitter functions the host manufacturer is responsible for ensuring compliance with the module(s) installed and fully operational. For example, if a host was previously authorized as an unintentional radiator under the Declaration of Conformity procedure without a transmitter certified module and a module is added, the host manufacturer is responsible for ensuring that after the module is installed and operational the host continues to be compliant with the Part

15B unintentional radiator requirements.The module is limited to OEM installation ONLY.

The module is limited to installation in mobile or fixed application.We hereby acknowledge our responsibility to provide guidance to the host manufacturer in the event that they require assistance for ensuring compliance with the Part 15 Subpart B requirements.

IMPORTANTNOTE: In the event that these conditions cannot be met (for example certain laptop configurations or co-location with another transmitter),then the FCC authorization is no longer considered valid and the FCC ID cannot be used on the final product.In these circumstances,the OEM integrator will be responsible for reevaluating the end product(including the transmitter) and obtaining a separate FCC authorization.