

ARIA

USER MANUAL

Contents

Introduction	4
Product Features	5
LED Indicators	6
What's Included	7
Wi-Fi Requirements	8
Mobile Device Requirements	8
Installation Requirements	9
Aria Installation	10
App Setup and Pairing	16
Storage Options	21
Your Dashboard	22
Light Controls	23
Siren Activation	24
Camera Functions	25
• Watching Live Video	25
• Taking Photos	26
• Recording Videos	26
• Audio Functions	27
Setting up Rules	28

• Triggers	28
• Adding a New Rule	28
• Mobile Alerts	29
Viewing Recorded Photos and Videos	30
Saving and Deleting recordings	31
Restoring Forgotten Passwords	32
Resetting the Device	33
Troubleshooting	34
About Momentum	34

© 2016 Momentum

Momentum is a registered trademark in the United States. Apple and iPhone are registered trademarks of Apple Inc. Google, Google Play, and Android are trademarks of Google LLC. All other brands and product names are or may be trademarks of their respective owners.

Note: Screen shots and procedures described in this manual are subject to change without notice. The latest Momentum User Guide is always available on our website at <http://www.momentumcam.com>.

Introduction

The **Aria** is an LED floodlight with wireless monitoring capabilities that can be accessed from anywhere with an internet connection. It's great for surveillance outside of your home or office and to make sure you always stay in control no matter where you are. All you need is a(n):

1. Existing floodlight you want to replace, or
2. Existing junction box and wiring in the mounting area
3. Compatible mobile device (Android or iOS)
 - *See page #6 for device requirements.*

Use your smartphone and/or tablet to use and manage the Aria and app's functions remotely.

Product Features

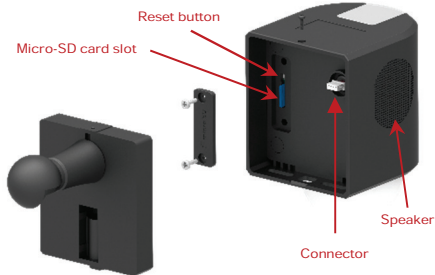
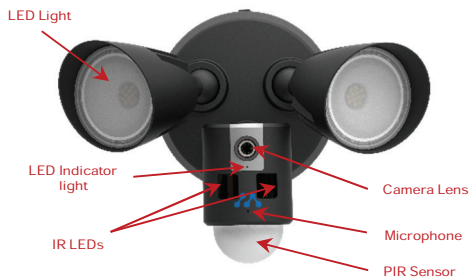

LED Indicators

The Aria displays an LED indicator light that lets you know what it is doing.

Solid Red Light: Aria is booting up.

Blinking Red Light: Failed to connect to Wi-Fi.

Blinking Red & Blue Light: Ready to connect to Wi-Fi.

Blinking Blue Light: Aria is connected to Wi-Fi.

Solid Blue Light: User is currently live streaming.

What's Included

Aria Floodlight



Gasket



Mounting Bracket



Screwdriver



Wire Nuts (x3)



#8 Long Bracket Screw



#10, #8, #6 Short Bracket

Screws (x2 each)



#10



#8



#6

Note: There are three sizes of screws provided. #8 is the most commonly used, however your junction box may use #10 or #6 size screws instead. Make sure to use the screw size that fits your junction box.

Wi-Fi Requirements

The Aria requires a 2.4GHz (802.11bg/n) for Wi-Fi connectivity. This is a standard home Wi-Fi router. You will need your Wi-Fi name and password when pairing your mobile device and the Aria.

Note: If you are using a 2.4GHz + 5 GHz dual band router, create separate SSID names for each band on your Wi-Fi router settings page. This will make it easier for you to select the 2.4GHz band for the device setup.

Mobile Device Requirements

The Momentum app requires a smart phone or tablet device that runs on **Android 4.4+ (Kit Kat)** for Android devices or **iOS 7.0+** for Apple devices.

Installation Requirements

1. To install the Aria, you must already have an existing floodlight you wish to replace or have a setup location with an installed junction box and available electrical wiring.
2. Voltage supplied to the Aria should be between 110-240VAC.
3. Setup location is recommended to be at least 6 to 10 feet from the ground.
4. Installation should be performed by qualified electricians who are informed about the standards and technical requirements of the appliance and its proper installation.
5. Do NOT connect the Aria to a dimmer switch or timer.
6. Ensure the mounting surface and junction box are waterproofed and completely sealed.
7. The Aria cannot be mounted on a ceiling or upside down (i.e. it must be mounted on a wall).

Aria Installation

Before you begin:

- Shut OFF the power at the fuse or circuit breaker box.
- DO NOT rely on a wall switch alone to turn off the power.
- If you're unsure which switch it is to turn off the floodlight's power, please consult with a licensed electrician.
- **WARNING: Failing to shut off the power could result in a serious injury, electrical shock, and/or risk of fire.**
- You will likely require a ladder to reach the setup location. It's recommended you have someone to assist you during installation to minimize risk of injury.



Assembly Guide

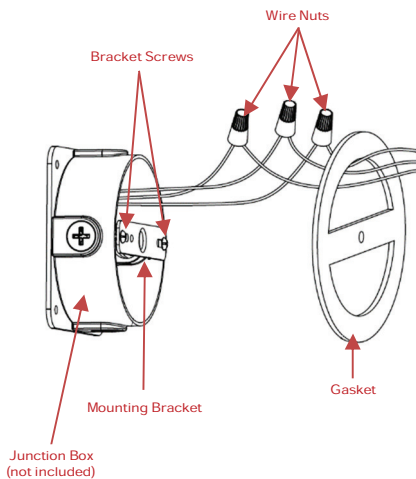

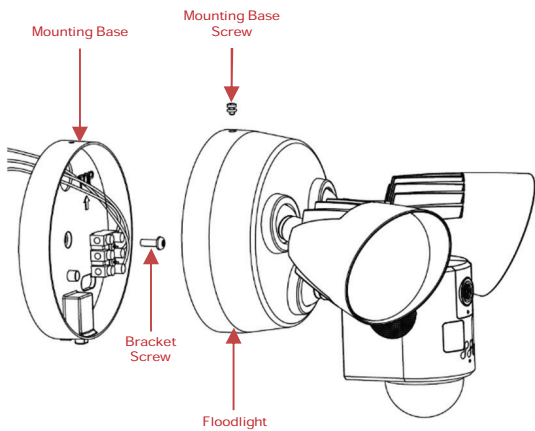

Step 1: Download the Momentum App

Download and install the Momentum app on your mobile device.

Search for **Momentum** on the Google Play Store for Android devices, or on the Apple App Store for iOS devices. You may also scan the QR code below from your mobile device to route you directly to the app.

Make sure the app logo you download matches the one shown below.



momentum



Create an Account

If you don't already have a Momentum account, you will need to create one. To create a new account, follow the in-app instructions.

Step 2: Remove your existing floodlight

- NOTE: Your power to the floodlight should be off already at this point from the breaker box.
- Use a screwdriver or another tool (depending on your floodlight) to remove the floodlight from the junction box.
- Disconnect the wires from the floodlight.
- If there is a mounting bracket attached to your junction box, you may remove that as well.

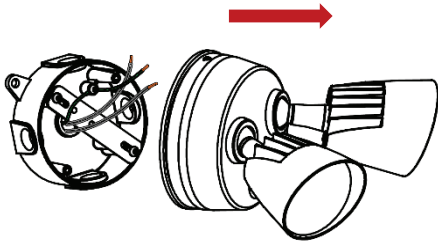

Step 3: Install the new mounting bracket and gasket

- Use the provided screws in the box to install the mounting bracket onto your junction box. Make sure it is tight and secure.
- With the provided gasket, peel off the white tape and stick that side around the wall opening. **Make sure the center hole lines up with the center bracket hole and that there are no openings around the gasket.**

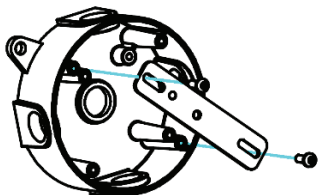

Step 4: Connect the wires

- You should see three sets of wires: a ground wire (usually green or copper), black wire, and white wire.
- The Aria's mounting base will have its own set of the same wires. Note that the open side of the mounting

base should be facing outwards away from the house (see pg.12 for reference).

- Use the provided wire nut to twist the open ends of the ground wires from your home's junction box and the Aria's mounting base together.
- Then, do the same for the two black wires and the two white wires.
- Push all the excess wiring into the junction box.

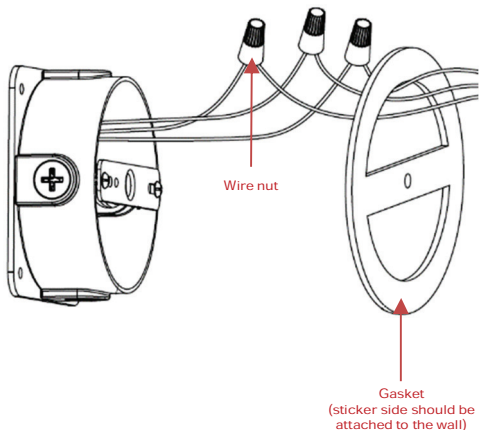

Step 5: Install the mounting base

- First, make sure that the mounting base is set properly so that the top screw hole is positioned at the very top.
- With the provided #8 long screw, push the screw through the middle screw-hole of the mounting base. It should also pass through the gasket and finally into the middle of the mounting bracket. Use the provided screwdriver to secure it tightly.
- Ensure that the gasket and base is tight and does not move.

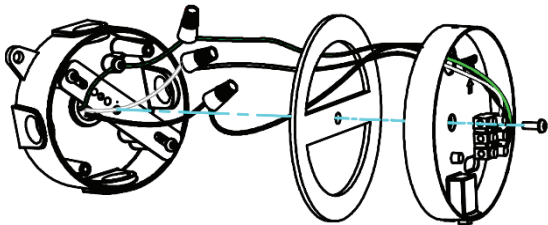

Step 6: Mount the Aria

- The floodlight can now be mounted onto the mounting base. Make sure the screw-hole at the top matches on both the mounting plate and the floodlight, then use the provided screw and screwdriver to screw them tightly in place.



Step 7: Turn on the power

- Turn on the power from the power breaker to provide power back to the Aria. You should hear a sound play from the Aria that it's ready to pair.

Step 8: Pair the Aria

Note: Your Aria should already be installed and powered on before pairing.

To begin using your Aria, you will first need to pair it to your Momentum account and then connect it to your Wi-Fi network.

- Once your Aria has been powered on the first time, it should already be put into pairing mode. There will also be a sound played to notify you that it's in pairing mode as well.
- If it's not in pairing mode, you will need to open up the camera and hold down the reset button within the camera for 3 seconds. You should hear an audio play that the camera has been put into pairing mode.

1. Connect to the Aria's Wi-Fi access point.

- From the app, select the Aria device option, then proceed until you're instructed to connect to the Aria's Wi-Fi access point.

- From your mobile device's Wi-Fi settings, find the Wi-Fi network with the name “**ARIA**” and connect to it.
- Once you're connected, go back to the app.

2. Connect to your Wi-Fi network.

- Select the Wi-Fi network you want your Aria to be connected to. Enter in the network credentials if necessary.

3. Configure the Floodlight and Camera settings.

- Name your device, then customize your light schedules and motion zones to your preference.
- Once you've finished customizing your options, your setup is complete!

Storage Options

Your Momentum Aria can save your recorded videos or pictures through the **Momentum Capture Cloud Storage** subscription plan or with your own **micro-SD card** inserted into the device.

The micro-SD card slot can be found inside the camera device. *(see pg. 5)*

Micro-SD Card Storage

If you'd prefer not to use a cloud based storage subscription plan, you can opt to use your own micro-SD card (up to 128GB) instead.

You will need to unscrew and snap off the camera to access the slot. Then insert the micro-SD card, then configure the SD card from the device settings in the app. Once the memory capacity has been reached on the card, the new recording will loop over and begin to overwrite the earliest saved recordings.

Your Dashboard

Your dashboard is your app's home screen where you can view and access your paired devices. You can rearrange the **Tiles** on your dashboard by tapping the **Pencil** icon in the top right corner of the app. You can also make some device tiles larger or smaller when editing your dashboard. Be sure to tap the **Save Dashboard** button at the bottom when you are finished editing.

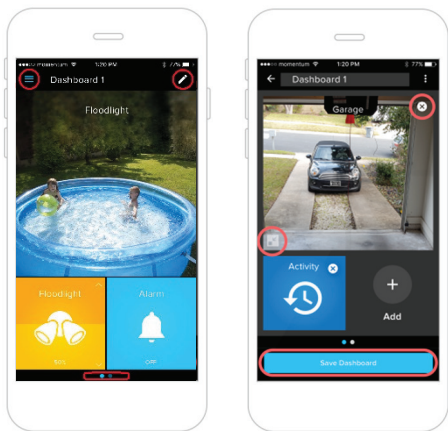

Light Controls

After pairing your Aria, a light control tile will be available for your app's dashboard screen.

To manually turn on the lights for your Aria, simply tap on the control tile. Tap the tile again to turn it off.

You can also adjust the brightness of the floodlights by pressing the up or down arrow on the tile.

You can also control the light from the Aria camera's live view screen.

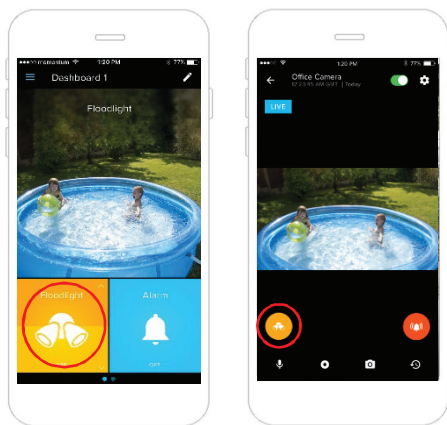

Siren Activation

Your Aria has a built-in siren that is loud enough to scare away any perpetrators.

You can activate the siren from the Siren Tile or the Aria live view screen.

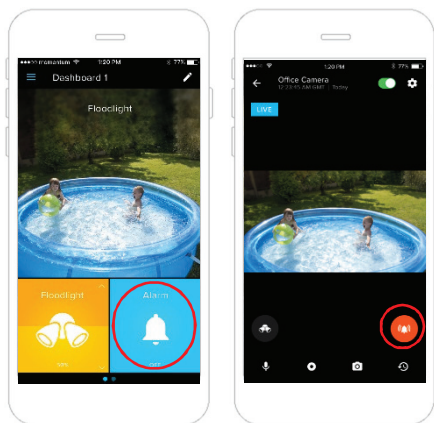

Camera Functions

Your Momentum Aria has several functions you can control through the Momentum app. To enter the camera controls, select the **camera tile** from the dashboard.

Camera tile

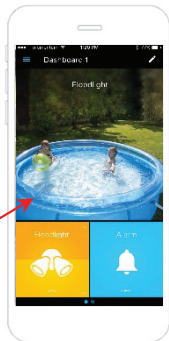

Watching Live Video

To view live video stream, first select the **Camera tile**.

Rotate your mobile device to view in either portrait mode or landscape mode.

In **portrait mode** you can use your fingers to pan around the video feed. **Landscape mode** will display the video in full screen mode. You may use your fingers to pinch to zoom in on the video as well.

Note: You do not need a micro-SD memory card nor a cloud storage subscription for live video streaming.

Taking Photos

Tap the **Camera** icon to save a screenshot while watching live video.

To save images taken from your Aria you must either have a:

1. **Micro-SD card** inserted into the camera, or
2. **Cloud storage subscription** for the specific device through the Momentum app.

Recording Videos

Tap the **Record Video** icon to start recording.

Tap the **Record Video** icon again to stop recording.

To save you must either have a:

1. **Micro-SD card** inserted into the camera.
2. **Momentum Capture** cloud storage subscription.

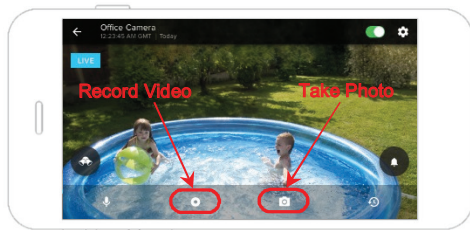

Audio Functions

You can engage in two-way conversations while you're in the Aria's live video stream option. Note that the audio will only go through one source (camera or app) at a time.

To speak through the app to the Aria, tap on the **Microphone** icon. You must tap on the icon again to de-select it to begin hearing the Aria's side again.

To only listen through the Aria's audio, make sure the **Microphone** icon is de-selected.

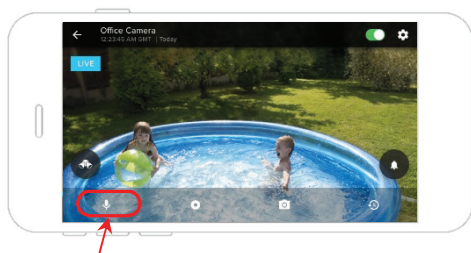

Microphone Button

Setting up Rules

Your Aria will record video when rules have been set through the Momentum App. **Rules** allow your device to activate and monitor the area while you are not watching the live stream. Set **triggers** to have your Aria activate under certain conditions.

Triggers

You can set a trigger for the Aria to have it start automatically recording after detecting motion.

Adding a New Rule

Add the days of the week and times of the days you want this rule to be set in place. The trigger you have chosen will then set off an action of your choosing, such as **Take video clip** with the device you have selected.

Mobile Alerts

Once you have created a **Rule** set to your chosen parameters, you will receive a notification alert to your mobile device if an event is triggered.

If you'd like to stop receiving alerts, you must turn it off from your mobile device's notification settings for the Momentum App, or turn off the **Rules** or **Triggers** directly from the Momentum App.

You may also view all of your previous alerts by tapping the **Activity** tile on your Dashboard.

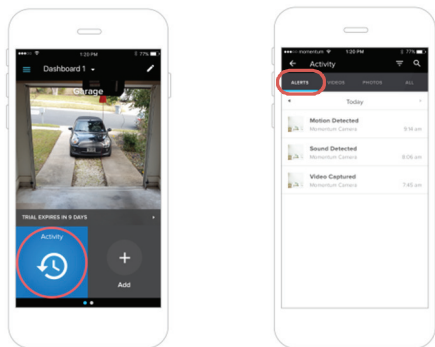

Viewing Recorded Photos and Videos

On the Home screen, tap the **Activity** tile to view recorded videos, captured photos, or alerts for a specific day. You can also access the activity list from the live camera view.



When you select a video in your activity list, it will begin playing back automatically. To rewind or fast forward, tap the video to reveal the video playback controls.

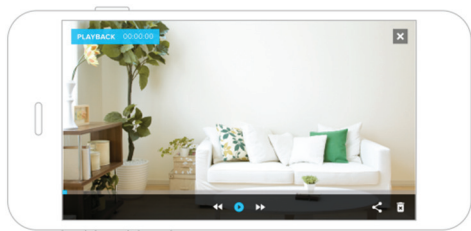

Saving and Deleting Recordings

If you have purchased a cloud subscription and set up a rule for recordings, footage of those recordings will be automatically saved onto the cloud for the predetermined time, depending on which plan you have purchased.

If you have inserted your own micro-SD card and set up a rule for recordings, footage of those recordings will be saved on the micro-SD card until the storage becomes full and loops back over to record over your previous recordings.

However, if you'd like to save your cloud or micro-SD card recordings to your mobile device's local storage, you can do so while you're viewing the specific recording. Press the 'save' button at the bottom right corner to save a copy of the footage onto your mobile device's local storage.

You may also delete the recording permanently off your cloud storage or micro-SD card by tapping the 'delete' icon at the top right corner of the screen while viewing the recording.

Restoring Forgotten Passwords

If you've forgotten your login password, tap on the **Forgot Password** button at the sign in page. You will receive an email with instructions to guide you through the rest of the way.

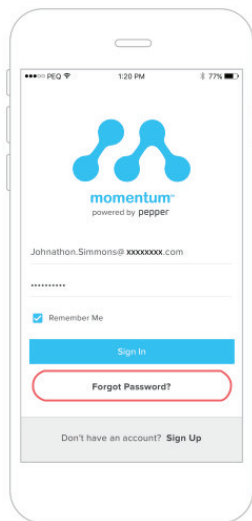

Resetting the Device

If your Momentum Aria is having connection issues, most of the time a reset will fix the issue.

1. To reset your Aria, detach the camera from the floodlight (but still leave the wires connected) and **hold the reset button inside the camera for 10 seconds.**
2. The Aria will then be ready to connect to the Wi-Fi again. You will need to follow the pairing process again (see instructions for pairing).

Troubleshooting

Assistance is available both in the app and on the Momentum website.

- To access the most current version of the user's manual, tap the **Menu** icon to launch the screen with a menu bar and tap **Support**.
- For further assistance, go to <https://www.momentumcam.com/help/>

About Momentum

Momentum provides an easy-to-setup home security camera that connects to your smart phone or tablet giving you real-time video streaming and two-way voice communication – anywhere, anytime. Momentum subscribers also have access to IOT cloud-based storage for camera-captured videos from a user-friendly mobile app. Whether you want to check on your babysitter, are wondering what your pets are doing, or are leaving for vacation, you'll always have an eye in your home with Momentum.

For more information, please visit
www.momentumcam.com or contact us at
help@momentumcam.com.

FCC Compliance

This device complies with part 15 of the FCC Rules. Operation is subject to the following two conditions:

1. This device may not cause harmful interference, and
2. This device must accept any interference received, including interference that may cause undesired operation.

Note: This product has been tested and found to comply with the limits for a Class B digital device, pursuant to Part 15 of the FCC Rules. These limits are designed to provide reasonable protection against harmful interference in a residential installation. This product generates, uses, and can radiate radio frequency energy and, if not installed and used in accordance with the instructions, may cause harmful interference to radio communications. However, there is no guarantee that interference will not occur in a particular installation. If this product does cause harmful interference to radio or television reception, which can be determined by turning the equipment off and on, the user is encouraged to try to correct the interference by one or more of the following measures:

- Reorient or relocate the receiving antenna.
- Increase the separation between the equipment and receiver.

- Connect the equipment into an outlet on a circuit different from that to which the receiver is connected.
 - Consult the dealer or an experienced radio/TV technician for help.
- Please take attention that changes or modification not expressly approved by the party responsible for compliance could void the user's authority to operate the equipment.

This equipment should be installed and operated with a minimum distance 20cm between the radiator and your body

Apollo Tech USA, Inc.

8608 Utica Ave. #220,

Rancho Cucamonga, CA 91730

Customer Service: +1 888 818 0436

E-mail: help@momentumcam.com

Version 1.0