



## **DS-K1100 Series Card Reader**

### **Installation Manual**

UD.6L0206A1004A01

## **Regulatory information**

### **FCC information**

This device complies with Part 15 of the FCC Rules. Operation is subject to the following two conditions:

- (1) This device may not cause harmful interference.
- (2) This device must accept any interference received, including interference that may cause undesired operation.

Please take attention that changes or modification not expressly approved by the party responsible for compliance could void the user's authority to operate the equipment.

**FCC compliance:** This product has been tested and found to comply with the limits for a Class B digital device, pursuant to Part 15 of the FCC Rules. These limits are designed to provide reasonable protection against harmful interference in a residential installation. This product generates, uses, and can radiate radio frequency energy and, if not installed and used in accordance with the instructions, may cause harmful interference to radio communications. However, there is no guarantee that interference will not occur in a particular installation. If this product does cause harmful interference to radio or television reception, which can be determined by turning the equipment off and on, the user is encouraged to try to correct the interference by one or more of the following measures:

- Reorient or relocate the receiving antenna.
- Increase the separation between the equipment and receiver.
- Connect the equipment into an outlet on a circuit different from that to which the receiver is connected.
- Consult the dealer or an experienced radio/TV technician for help.

This equipment should be installed and operated with a minimum distance 20cm between the radiator and your body.

Thank you for purchasing our product. If there is any question or request, please do not hesitate to contact the dealer.

This manual is applicable to the following models:

Series	Models	Description
DS-K1101 Series	DS-K1101M	MIFARE card reader (without keypad)
	DS-K1101MK	MIFARE card reader (with a keypad)
	DS-K1101C	CPU card reader (without keypad)
	DS-K1101CK	CPU card reader (with a keypad)
DS-K1102 Series	DS-K1102M	MIFARE card reader (without keypad)
	DS-K1102MK	MIFARE card reader (with a keypad)
	DS-K1102C	CPU card reader (without keypad)
	DS-K1102CK	CPU card reader (with a keypad)
DS-K1103 Series	DS-K1103M	MIFARE card reader (without keypad)
	DS-K1103MK	MIFARE card reader (with a keypad)
	DS-K1103C	CPU card reader (without keypad)
	DS-K1103CK	CPU card reader (with a keypad)
DS-K1104 Series	DS-K1104M	MIFARE card reader (without keypad)
	DS-K1104MK	MIFARE card reader (with a keypad)
	DS-K1104C	CPU card reader (without keypad)
	DS-K1104CK	CPU card reader (with a keypad)

This manual is a kind of guide only for reference and may contain several technically inaccurate points or printing errors, and the content is subject to change without notice. The updates will be added into the new version of this manual. We will readily improve or update the products or procedures described in the manual.

There may be differences between real object. The real product should be considered as final.

## Chapter 1 Preventive and Cautionary Tips

To guarantee the card reader works properly, please read and obey the notes below.

- If the card reader is powered by the controller, the power supply distance is recommended to be no longer than 100m. If the distance is longer than 100m, you are advised to power the card reader by external 12V (range: -%10 ~ +%10) DC power supply, which is nonswitched and linear.
- To guarantee the communication between the controller and the card reader, you must use RVVP cable above 0.5 to connect them.
- If the card reader is installed outside or in environment easy to permeable, it is advisable to install a waterproof shield.
- If you need to install several card readers, the distance among them must over 30cm.
- To reduce the noise in long distance transmission, the shield of cable should connect to the GND of both controller and card reader terminal.

## Chapter 2 Introduction

DS-K1100 series card reader is a kind of high-performance product, with a 32 bit high-speed processor. It communicates with access controller via either RS-485 protocol or Wiegand protocol. And a build-in tamper-proof module helps to protect card reader from malicious damage. As to the physical appearance, the PC+ABS material makes water proof and dust proof possible in poor environment.

## 2.1 Front View

The front view of DS-K1101 series card reader is shown below:

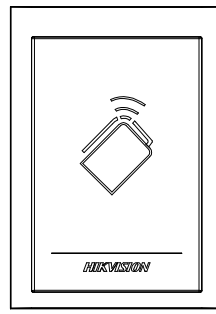
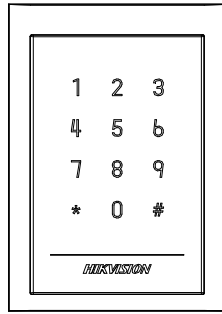

Figure 2-1 DS-K1101MK/DS-K1101CK      Figure 2-2 DS-K1101M/DS-K1101C

The front view of DS-K1102 series card reader is shown below:

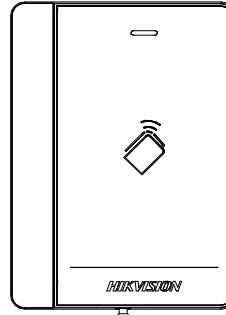
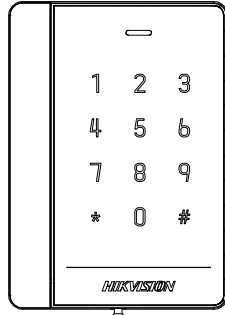

Figure 2-3 DS-K1102MK/DS-K1102CK      Figure 2-4 DS-K1102M/DS-K1102C

The front view of DS-K1103 series card reader is shown below:

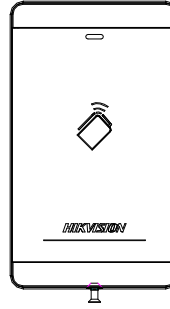
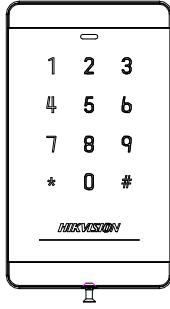

Figure 2-5 DS-K1103MK/DS-K1103CK      Figure 2-6 DS-K1103M/DS-K1103C

The front view of DS-K1104 series card reader is shown below:

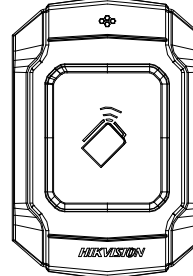

Figure 2-7 DS-K1104MK/DS-K1104CK      Figure 2-8 DS-K1104M/DS-K1104C

## 2.2 Rear View

The rear view of card reader is shown below:

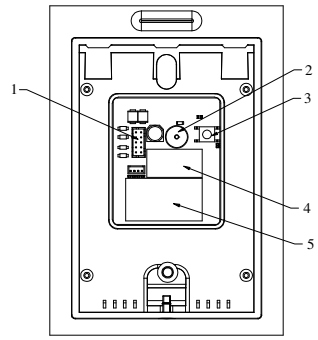

Figure 2-9 Rear View of DS-K1101 Series

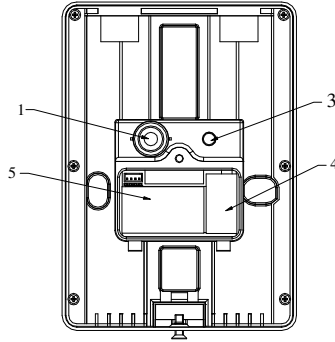

Figure 2-10 Rear View of DS-K1102 Series

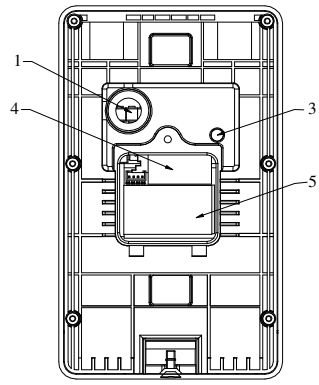

Figure 2-11 Rear View of DS-K1103 Series

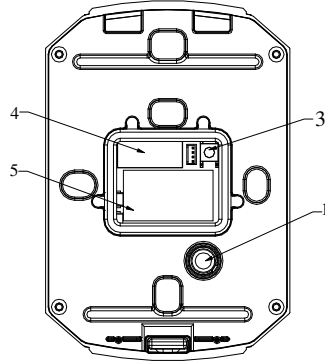

Figure 2-12 Rear View of DS-K1104 Series



Table 2-1 Description of Rear View

No.	Name
1	Cable Interface of RS-485, Power, LED Control, etc.
2	Buzzer
3	Tamper-proof Module
4	DIP Switch
5	PSAM Card Slot (available for CPU card reader)

### 2.3 Side View

The side view of card reader is shown below:



Figure 2-13 DS-K1101 Series

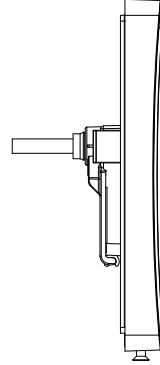

Figure 2-14 DS-K1102 Series

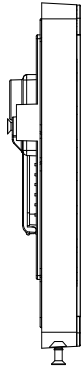

Figure 2-15 DS-K1103 Series

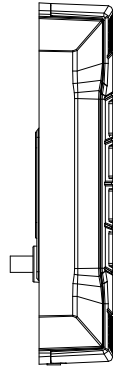

Figure 2-16 DS-K1104 Series

## Chapter 3 Installation

### 3.1 Installing PSAM Card



PSAM card slot is only available for CPU card reader.

Insert the PSAM card into the slot according to the direction shown below.

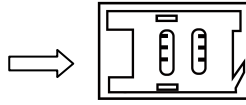

Figure 3-1 PSAM Card Slot

### 3.2 Introduction for DIP Switch

The DIP switch module is shown below. The No. of DIP switch from left to right is 1 ~ 8.



Figure 3-2 DIP Switch Module

Table 3-1 Description of DIP Switch

Icon	Description
	Represent 1 in binary mode
	Represent 0 in binary mode

For example, binary value of the following status is: 0000 1100.



Figure 3-3 DIP Switch Module

Table 3-2 Description of DIP Switch

No.	Description	DIP Switch Status
1 ~ 4	Address of RS-485	1: 1 0: 0
5	Read card No. or file in card. (Only available for CPU card reader.)	1: read card No; 0: read file in card.
6	Wiegand protocol or RS-485 protocol.	1: Wiegand protocol; 0: RS-485 protocol.

No.	Description	DIP Switch Status
7	Wiegand Protocol (available when No. 6 is 1)	1: Wiegand protocol of 26-bit; 0: Wiegand protocol of 34-bit.
8	Matched Resistance (available for RS-485 protocol)	1: Enable; 0: Disable.

### 3.3 Definition of Cable

The description of 10 cables is shown below.

Table 3-3 Description of Cable

Color	Description
Yellow	RS-485+
Brown	Blue LED Control (available for Wiegand Protocol)
Blue	RS-485-
Purple	Beep Control (available for Wiegand Protocol)
Gray	Case Sensor (available for Wiegand Protocol)
Green	Wiegand W0 (available for Wiegand Protocol)
White	Wiegand W1 (available for Wiegand Protocol)
Black	GND
Orange	Red LED Control (available for Wiegand Protocol)
Red	PWR (DC +12V)

### 3.4 Wiring Cables

**Purpose:**

Wire the cables between controller and card reader, thus to establish the communication between them.

**Steps for RS-485 communication mode:**

1. Set the DIP switch of No. 6 as 0.
2. Set the DIP switch of No. 1 ~ 5 for RS-485 address and reading card mode. For details, please refer to 3.2 *Introduction for DIP Switch*.
3. Wire the cable between controller and card reader as shown below.

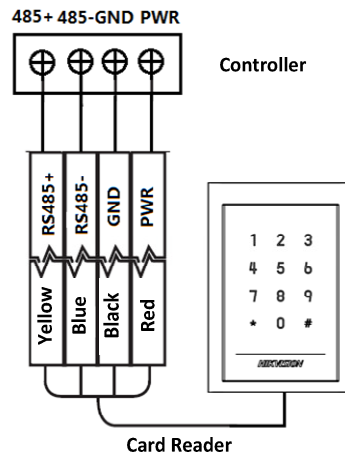

Figure 3-4 Wiring for RS-485 Communication Mode

**Steps for Wiegand communication mode:**

1. Set the DIP switch of No. 6 as 1.
2. Set the DIP switch of No. 5 and 7 for reading card mode and Wiegand protocol. For details, please refer to 3.2 *Introduction for DIP Switch*.

3. Wiring the cable between controller and card reader as shown below.

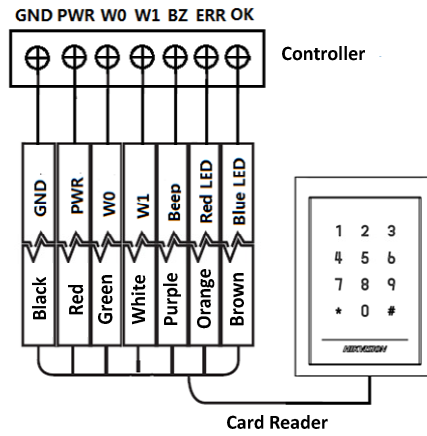

Figure 3-5 Wiring for Wiegand Communication Mode

### 3.5 Installing Card Reader

**Before you start:**

Set the DIP switch. For details, refer to [3.2 Introduction for DIP Switch](#).

**Steps:**

1. Fix the plate on the wall or other place.

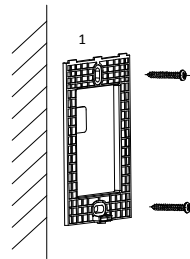

2. Connect the cables between controller and card reader. For details, refer to 3.4 Wiring Cables.
3. Push the card reader to match the fixed plate.
4. Fasten the screw to keep the components together.

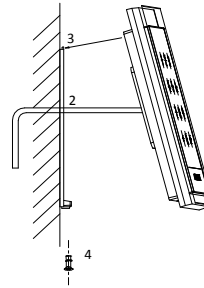

## Chapter 4 Sound Prompt and Indicator

After the card reader is powered on, LED status indicator will turn blue and blink for 1 time. Then it will turn red and blink for 3 times. At last the buzzer will send out a beep sound indicating the starting up process is completed.

During using the card reader, it will send out different sounds prompt and the LED indicator on it have different statuses. You can refer to tables below for detailed information.

Table 4-1 Description of Prompt Sound

Sound Prompt	Description
One beep	RS-485 protocol: Pressing keys prompt; Swiping card prompt; Time out prompt for pressing keys or swiping card. Wiegand protocol: Pressing keys prompt; Swiping card prompt.
Two rapid beeps	The operation of pressing keys or swiping card is valid.
Three slow beeps	The operation of pressing keys or swiping card is invalid.
Rapidly continuous beeps	Alarm of tamper-proof.
Slowly continuous beeps	The card reader is unencrypted.

Table 4-2 Description of LED Indicator

LED Indicator Status	Description
Blue and blinking	Card reader is working normally.
Solid blue	The operation of pressing keys or swiping card is valid.
Solid red	The operation of pressing keys or swiping card is invalid.
Red and blinking	For RS-485 protocol: Registering failed or card reader is offline.
Red and Keeping rapidly blinking	Available for reading file mode of CPU card: PSAM is not inserted or undetected.
Red and keeping rapidly blinking and slowly beeps	Failed to get key files of PSAM card; Failed to detect the PSAM card.



**First Choice for Security Professionals**

©Hikvision. All Rights Reserved.