

# LifeSmart

Simply, Brilliant

**BLEND™ Light Strip** Model. LS065  
 Setting up your LifeSmart™ BLEND™ Light Strip  
 User Guide Version 1.0

## PRODUCT INTRODUCTION

BLEND™ Light Strips are the perfect way to add ambience to any room and with its unique flexibility to be concealed almost anywhere, you can showcase your favorite works of art. Capable of creating 16 million different lighting effects with adjustable brightness and preset modes, you can always easily set the mood for that romantic dinner and seamlessly let it transition into a party setting. Even better is BLEND's interaction with your entire LifeSmart™ Smart Home System. Let your lights change to your desired ambience based on the time of day, temperature, or even by opening a door. You are only limited by imagination in the infinite applications of BLEND™ products to create unique atmospheres and instant, unique special moments. Not only that, but you will benefit from all of the amazing new technologies that LifeSmart™ is bringing to life, such as LifeSmart™ Cloud services and emotion recognition technology, so that your home knows how to meet your needs without even you realizing it. Brilliant and simple, get ready to experience carefree smart home living that the whole family can enjoy.

## Disposal And Recycling Information

This symbol indicates that this product and/or battery should not be disposed of with household waste. When you decide to dispose of this product and/or its battery, do so in accordance with local environmental laws and guidelines.



## IN YOUR PACKAGE

- BLEND™ Light Strip 1
- Power Cable 1
- Smart Adapter 1
- User Guide 1

## SPECIFICATIONS

Size	2000*12*3.5mm
Weight	270g
Power	< 12W/m
Lighting Color	1600W colors + white light
LED Density	60pcs/m
Wireless Distance	400m (open field)
Operating Humidity	5 ~ 90%
Operating Temperature	-20 ~ 40°C
Operating Frequency	433MHz GFSK
Input Voltage	24V DC
Regulatory Certification	FCC ID: 2AJMI-00LS065 <b>CE RoHS</b>

## BLEND™ LIGHT STRIP

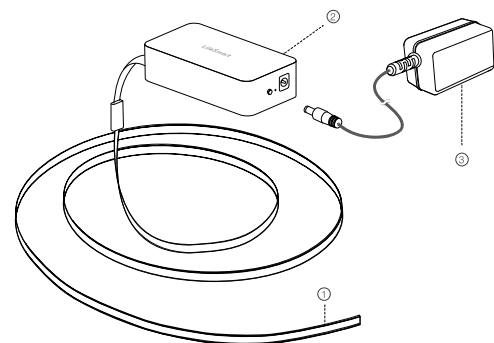

- ① BLEND™ Light Strip
- ② Light Strip Controller
- ③ Light Strip Power Adapter

## EASY SETUP

Your BLEND™ Light Strip requires a LifeSmart™ Smart Station and the LifeSmart™ App to operate. Please download the App to your smart device and set up your Smart Station before proceeding. The App is available by scanning the following QR Code or going directly to the Google Play or iOS App Store.

### ▶ Method 1



### ▶ Method 2



- 1 Open the LifeSmart™ App and initiate adding a device.
- 2 Attach the Light Strip Controller to the BLEND™ Light Strip and Power Adapter and plug the adapter to a power supply.
- 3 Press the back button on the BLEND™ Light Strip Controller for 5 seconds until the indicator light starts flashing to indicate that pairing is in progress.
- 4 You will be prompted in the App when pairing is complete.
- 5 You may now choose colors and dynamic effects via the LifeSmart™ App.

For technical support or FAQ's please visit us at [www.lifesmart.com](http://www.lifesmart.com) and find out how to contact our happiness team in your region.

## WARRANTY DESCRIPTION

Thank you for purchasing this LifeSmart™ product. In order to protect your rights, please read the following content carefully: The warranty period of our company's products is one year from the date of purchase or longer if local laws impose a longer minimum term, in which case the minimum term is the warranty period. During the warranty period, any faults caused by the product itself or for quality problems that arise under normal usage, LifeSmart™ will provide a free replacement.

## ATTENTION

The following conditions are not covered by the warranty:

- Product failure or damage caused by installation, use, and maintenance that is not in accordance with the product instructions;
- Products beyond the warranty period;
- Products that have the barcode tampered with or removed;
- Devices that have been tampered with or customized outside of LifeSmart™ Terms Of Service as on the LifeSmart™ App and website;
- User-caused damage, such as inappropriate voltage input, high temperature, accidental spillage, physical damage, etc;
- Product failure or damage caused by force majeure such as earthquakes, fires, or floods;
- Product failure or damage caused by other problems except the product itself.

## DECLARATION

LifeSmart™ is a trademark of Hangzhou LifeSmart Technology Co., Ltd. As for the trademarks, product logos and product names from other companies presented within this manual, they are possessed by their own right holders. Without our written permission, no entity or individual shall extract, copy or disseminate in part or the whole of the manual contents in any form. Due to product version upgrades or other reasons, content of this manual may change. Our company reserves the right to change the contents of this manual without any notice. This manual is used only for instructional purposes. We strive to provide accurate information in this manual, but we are not able to ensure that the content of this manual is current. Statements, information and advice in this manual do not constitute any expressed or implied assurance. Updated manuals are available on our website at [www.lifesmart.com](http://www.lifesmart.com) or by contacting our Happiness Team.

## FCC STATEMENT

1. This device complies with Part 15 of the FCC Rules. Operation is subject to the following two conditions:
  - This device may not cause harmful interference.
  - This device must accept any interference received, including interference that may cause undesired operation.
2. Changes or modifications not expressly approved by the party responsible for compliance could void the user's authority to operate the equipment.

### NOTE

This equipment has been tested and found to comply with the limits for a Class B digital device, pursuant to Part 15 of the FCC Rules. These limits are designed to provide reasonable protection against harmful interference in a residential installation.

This equipment generates uses and can radiate radio frequency energy and, if not installed and used in accordance with the instructions, may cause harmful interference to radio communications. However, there is no guarantee that interference will not occur in a particular installation. If this equipment does cause harmful interference to radio or television reception, which can be determined by turning the equipment off and on, the user is encouraged to try to correct the interference by one or more of the following measures:

- Reorient or relocate the receiving antenna.
- Increase the separation between the equipment and receiver.
- Connect the equipment into an outlet on a circuit different from that to which the receiver is connected.
- Consult the dealer or an experienced radio/TV technician for help.

