



BS24-U Module Datasheet

Version: 20230911

Contents

1	Overview	2
1.1	Features	2
1.2	Applications	2
1.3	New updates	2
2	Module interfaces	4
2.1	Dimensions and footprint	4
2.2	Pin definition	7
3	Electrical parameters	11
3.1	Absolute electrical parameters	11
3.2	Working conditions	11
3.3	Power consumption in working mode	12
4	RF parameters	14
4.1	Basic RF features	14
4.2	Transmitter (TX) performance	14
4.3	Receiver (RX) performance	14
5	Antenna information	16
5.1	Antenna type	16
5.2	Antenna interference reduction	16
6	Packing and production instructions	19
6.1	Mechanical dimensions	19
6.2	Side view	20
6.3	Schematic diagram	21
6.4	Recommended footprint	22
6.5	Production instructions	22
6.6	Recommended oven temperature curve	25
6.7	Storage conditions	28
7	MOQ and packaging information	29
8	Appendix: Statement	30



This topic describes Tuya's proprietary BS24-U Bluetooth low energy (LE) module. It consists of a highly integrated wireless RF chip EFR32BG24 and a few peripheral components, with a built-in Bluetooth protocol stack and various library functions.

1 Overview

BS24-U comes with a low-power 32-bit ARM Cortex-M33 core, 1024 KB of flash memory, 128 KB of RAM, and configurable GPIOs that can function as digital peripherals for various applications. This module integrates all MAC and TCP/IP libraries. All these resources can help develop your own embedded Bluetooth LE products.

1.1 Features

- Built-in low-power 32-bit CPU, ARM Cortex-M33 processor with DSP instruction and floating-point unit can act as an application processor.
- Clock rate of 78 MHz.
- Wide operating voltage range: 2.0V to 3.8V.
- Peripherals: nine GPIO pins, one UART pin, two ADC pins, and five PWM pins.
- Bluetooth LE radio frequency (RF) features
 - Bluetooth LE 5.3
 - RF data rate of up to 2 Mbit/s
 - Transmitter power: +17dBm
 - Receiver sensitivity: -96 dBm@Bluetooth LE 1 Mbit/s
 - Embedded hardware Advanced Encryption Standard (AES) encryption
 - Onboard PCB antenna with a gain of 1.2 dBi
 - Operating temperature: -40°C to +105°C

1.2 Applications

- Smart building
- Smart home and electrical appliance
- Smart socket and light
- Industrial wireless control
- Baby monitor
- IP camera
- Smart bus

1.3 New updates

Update date	Update content	Version
June 28, 2023	The first release.	v1.0.0

2 Module interfaces

2.1 Dimensions and footprint

BS24-U has three rows of pins. The pin spacing is 1.4 ± 0.1 mm on both sides and 1.8 ± 0.1 mm at the bottom.

The BS24-U dimensions are 20.3 ± 0.35 mm (L) \times 15.8 ± 0.35 mm (W) \times 2.5 ± 0.15 mm (H).

The following figure shows the dimensions and packaging design of the BS24-U module.

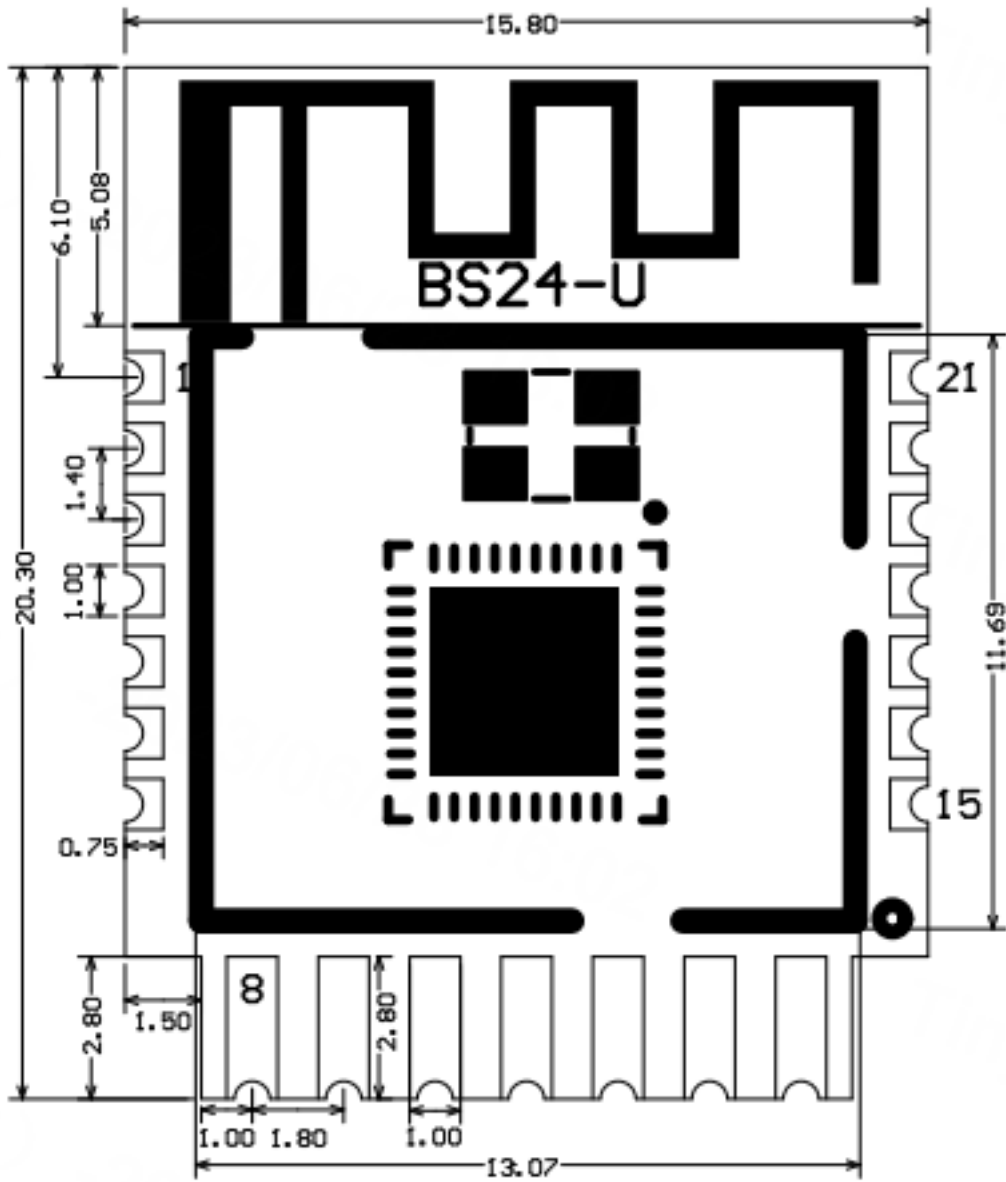

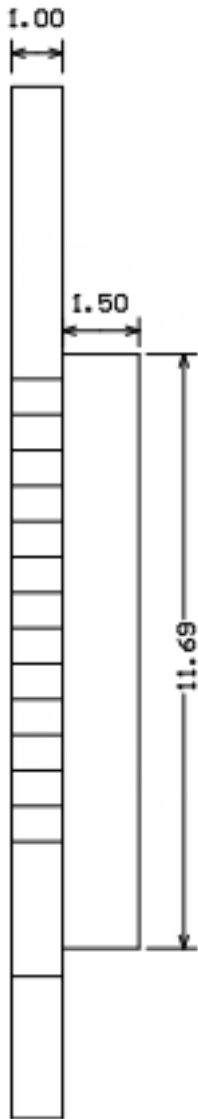

2.2 Pin definition

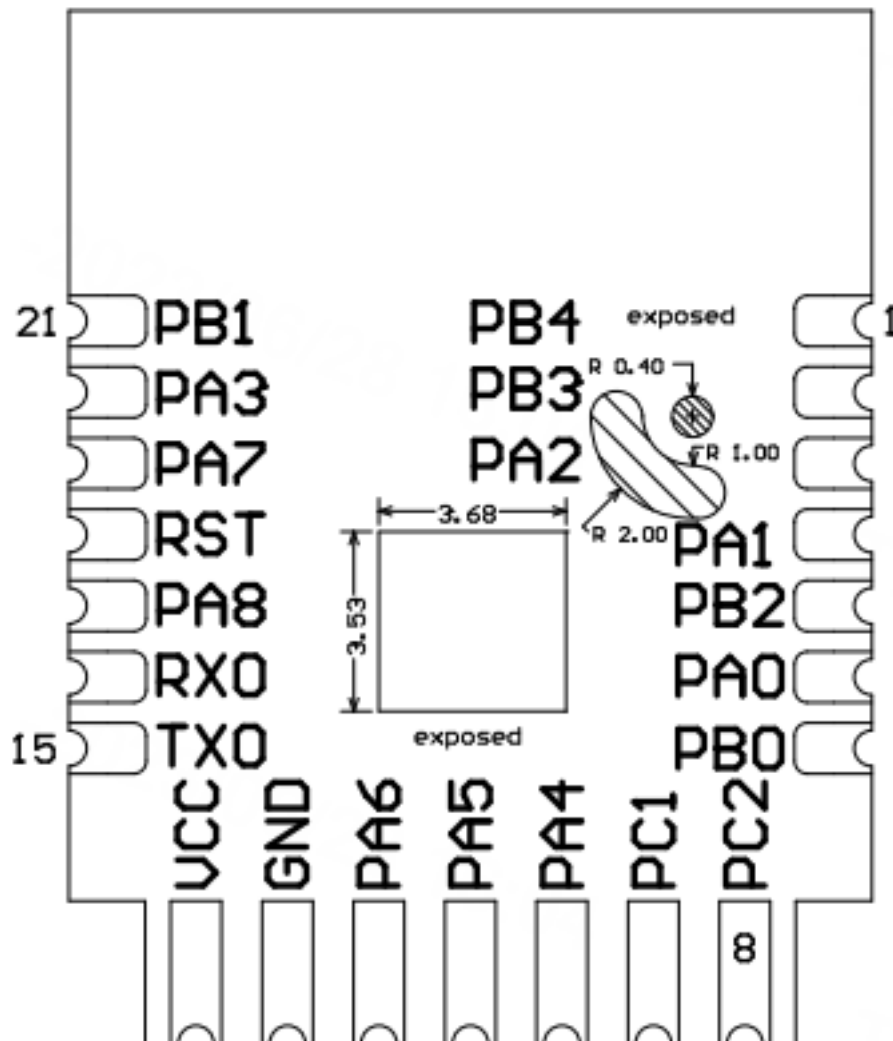

Pin No.	Symbol	I/O type	Feature
1	PB4	I/O	A normal I/O pin, corresponding to PB04 on the IC.
2	PB3	I/O	A normal I/O pin, corresponding to PB03 on the IC.

Pin No.	Symbol	I/O type	Feature
3	PA2	I/O	Used for firmware flashing, SWDIO, corresponding to PA02 on the IC.
4	PA1	I/O	Used for firmware flashing, SWCLK, corresponding to PA01 on the IC.
5	PB2	I	ADC pin, corresponding to PB02 on the IC.
6	PA0	I/O	A normal I/O pin, corresponding to PA00 on the IC.
7	PB0	I/O	A normal I/O pin, corresponding to PB00 on the IC.
8	PC2	I/O	Support hardware PWM, corresponding to PC02 on the IC.
9	PC1	I/O	Support hardware PWM, corresponding to PC01 on the IC.
10	PA4	I/O	Support hardware PWM, corresponding to PA04 on the IC.
11	PA5	I/O	Support hardware PWM, corresponding to PA05 on the IC.

Pin No.	Symbol	I/O type	Feature
12	PA6	I/O	Support hardware PWM, corresponding to PA06 on the IC.
13	GND	P	Ground pin.
14	VCC	P	Power supply pin (3.3V).
15	TX0	I/O	UART_TXD0 , used to flash the firmware and authorize the module, corresponding to PD03 on the IC.
16	RX0	I/O	UART_RXD0 , used to flash the firmware and authorize the module, corresponding to PD02 on the IC.
17	PA8	I	ADC pin, corresponding to PA08 on the IC.
18	RST	I/O	A reset pin, corresponding to RESETn on the IC. It is effective when pulled down.
19	PA7	I/O	A normal I/O pin, corresponding to PA07 on the IC.
20	PA3	I/O	A normal I/O pin, corresponding to PA03 on the IC.

Pin No.	Symbol	I/O type	Feature
21	PB1	I/O	A normal I/O pin, corresponding to PB01 on the IC.

:::info

- P indicates the power pin, and I/O indicates the input and output pin.
- Pins 3, 4, 13, 14, and 18 used for firmware flashing do not need to break out by default. Motherboard tracing shall keep away from these pins.

:::

3 Electrical parameters

3.1 Absolute electrical parameters

Parameter	Description	Min value	Max value	Unit
Ts	Storage temperature	-50	150	°C
VBAT	Supply voltage	2.0	3.8	V
Electrostatic discharge voltage (human body model)	TAMB -25°C	-	2	kV
Electrostatic discharge voltage (machine model)	TAMB -25°C	-	0.5	kV

3.2 Working conditions

Parameter	Description	Min value	Typical value	Max value	Unit
Ta	Operating temperature	-40	-	105	°C
VCC	Operating voltage	2.0	3.3	3.6	V
VIL	I/O low-level input	-	-	IOVDD × 0.3	V

Parameter	Description	Min value	Typical value	Max value	Unit
VIH	I/O high-level input	IOVDD × 0.7	-	-	V
VOL	I/O low-level input	-	-	IOVDD × 0.2	V
VOH	I/O high-level output	IOVDD × 0.8	-	-	V

3.3 Power consumption in working mode

Symbol	Condition	Typical value	Max value	Unit
I _{tx}	Continuous transmission, with an output power of 19.5 dBm	110	186	mA
I _{tx}	Continuous transmission, with an output power of 10 dBm	38	59	mA
I _{rx}	Continuous reception	7.3	9.7	mA
I _{DC}	Connected over Bluetooth mesh	6.8	210	mA

Symbol	Condition	Typical value	Max value	Unit
IEM2	Deep sleep mode (RAM reserved)	1.8	1.8	μA

4 RF parameters

4.1 Basic RF features

Parameter	Description
Operating frequency	2.4 GHz ISM band
Wireless standard	Bluetooth LE 5.3
Data transmission rate	1 Mbit/s and 2 Mbit/s
Antenna type	Onboard PCB antenna

4.2 Transmitter (TX) performance

TX continuous transmission performance

Parameter	Min value	Typical value	Max value	Unit
RF average output power	-	17	20	dBm
Bandwidth of 20 dB modulation signal (1 Mbit/s)	-	2500	-	KHz

4.3 Receiver (RX) performance

RX sensitivity

Parameter	Min value	Typical value	Max value	Unit	
RX sensitivity 1 Mbit/s	-	-96	-	dBm	
RX sensitivity 2 Mbit/s	-	-93.5	-	dBm	
Frequency offset error 1 Mbit/s	-250	-	+300	KHz	
Co-channel interference suppression	-	-	-10	dB	dB

5 Antenna information

5.1 Antenna type

PCB antenna is the default type of antenna.

5.2 Antenna interference reduction

When a PCB antenna is used on the module, we recommend that the module antenna is at least 15 mm away from other metal components. This can optimize the RF performance.

Make sure that the enclosure surrounding the antenna is not traced or filled with copper. Otherwise, the RF performance might be degraded.

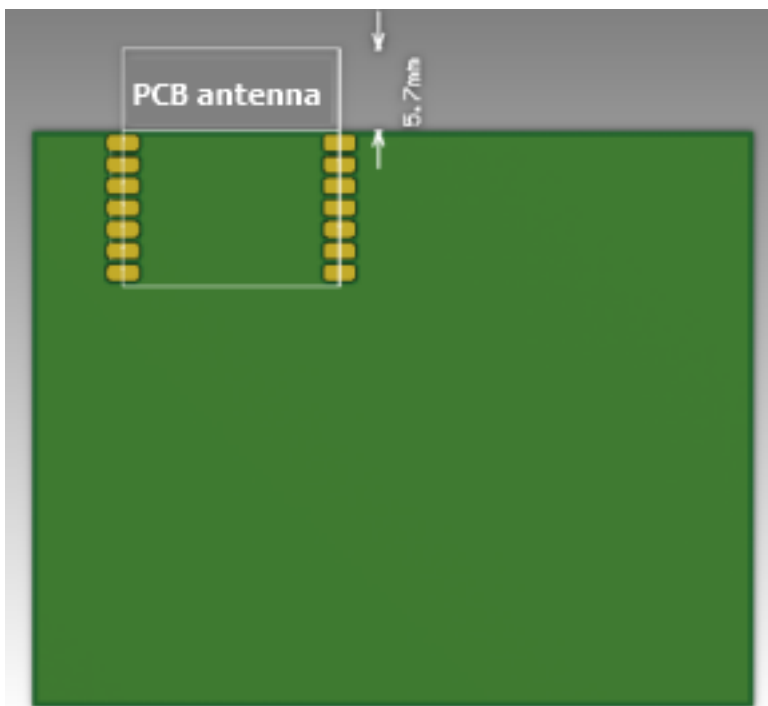

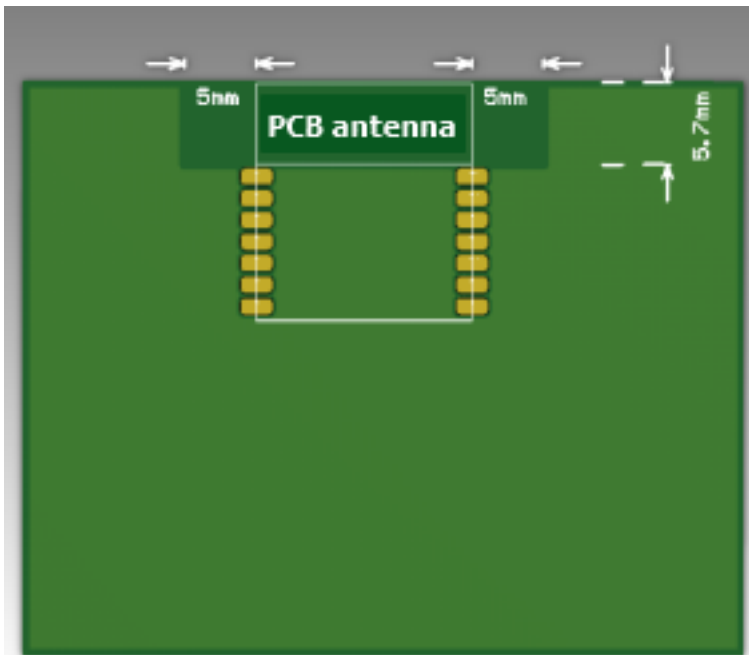
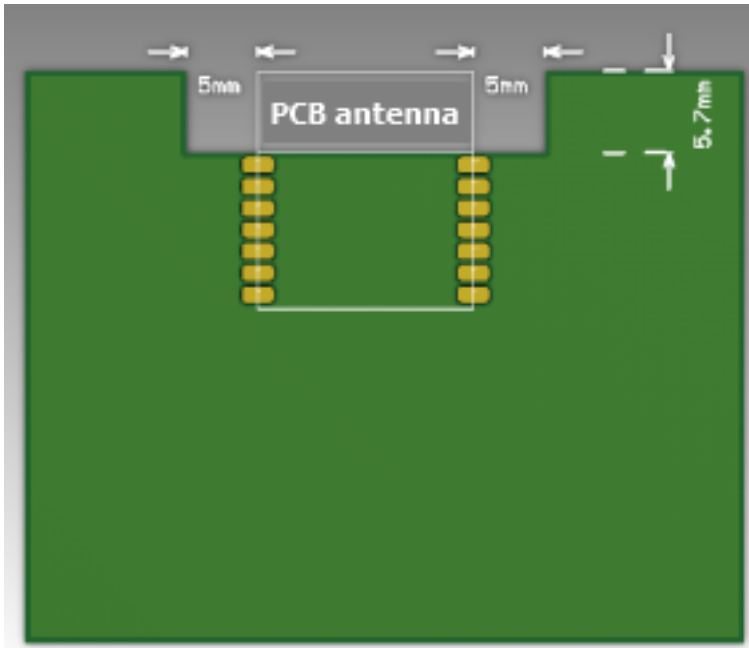

**Do not place any metal in the red area above the antenna.
The recommended diameter of the circular arc is greater than 3 cm.**

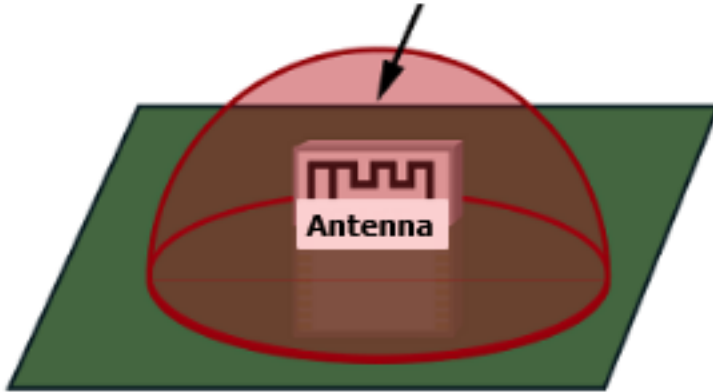

6 Packing and production instructions

6.1 Mechanical dimensions

The PCB dimensions are 20.3 ± 0.35 mm (W) \times 15.8 ± 0.35 mm (L) \times 1.0 ± 0.1 mm (H).

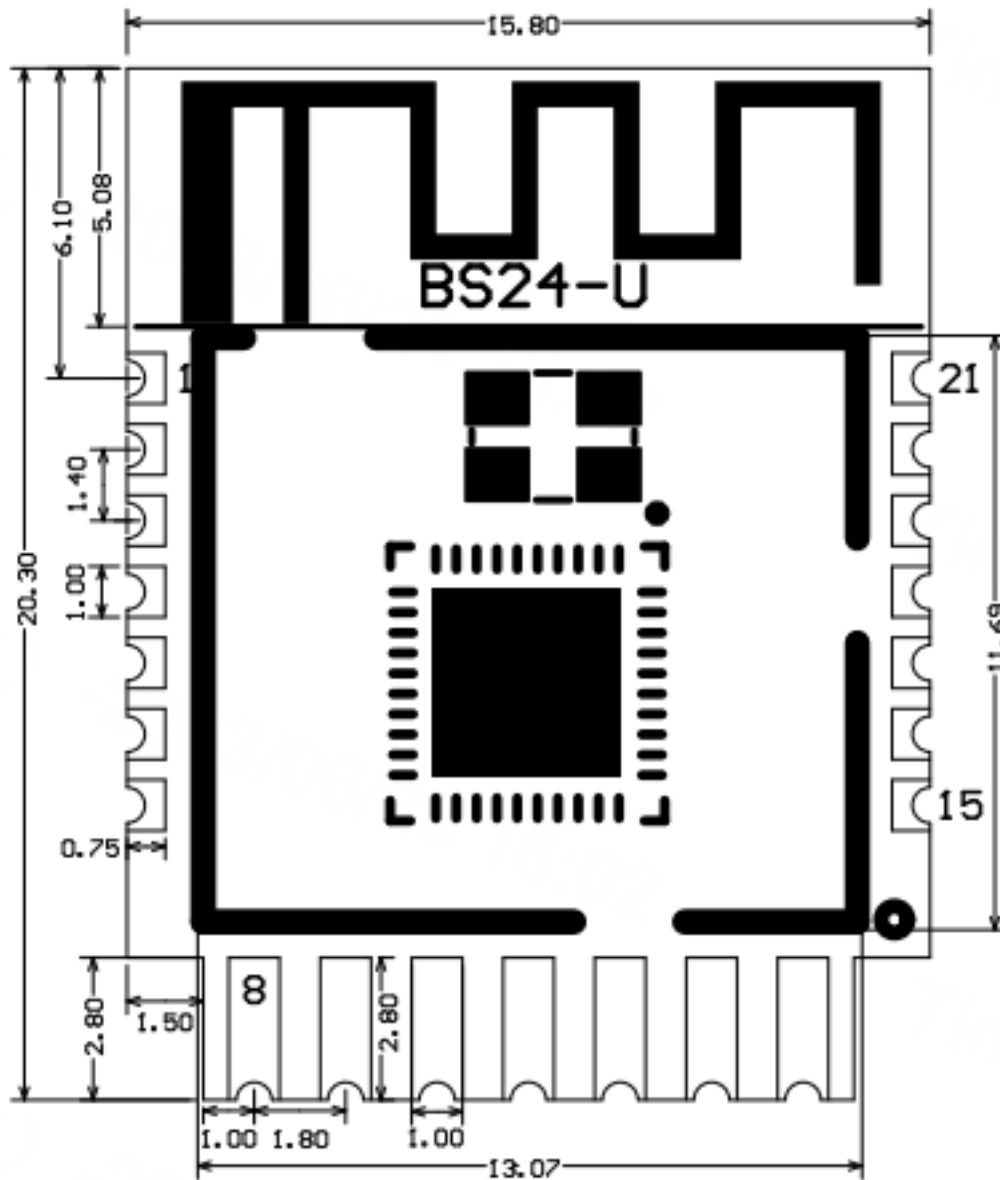

6.2 Side view



Unit: mm

Module form factor tolerance: $\pm 0.35\text{mm}$

PCB thickness tolerance: $\pm 0.1\text{mm}$

Shield cover height tolerance: $\pm 0.05\text{mm}$

Side View

6.3 Schematic diagram

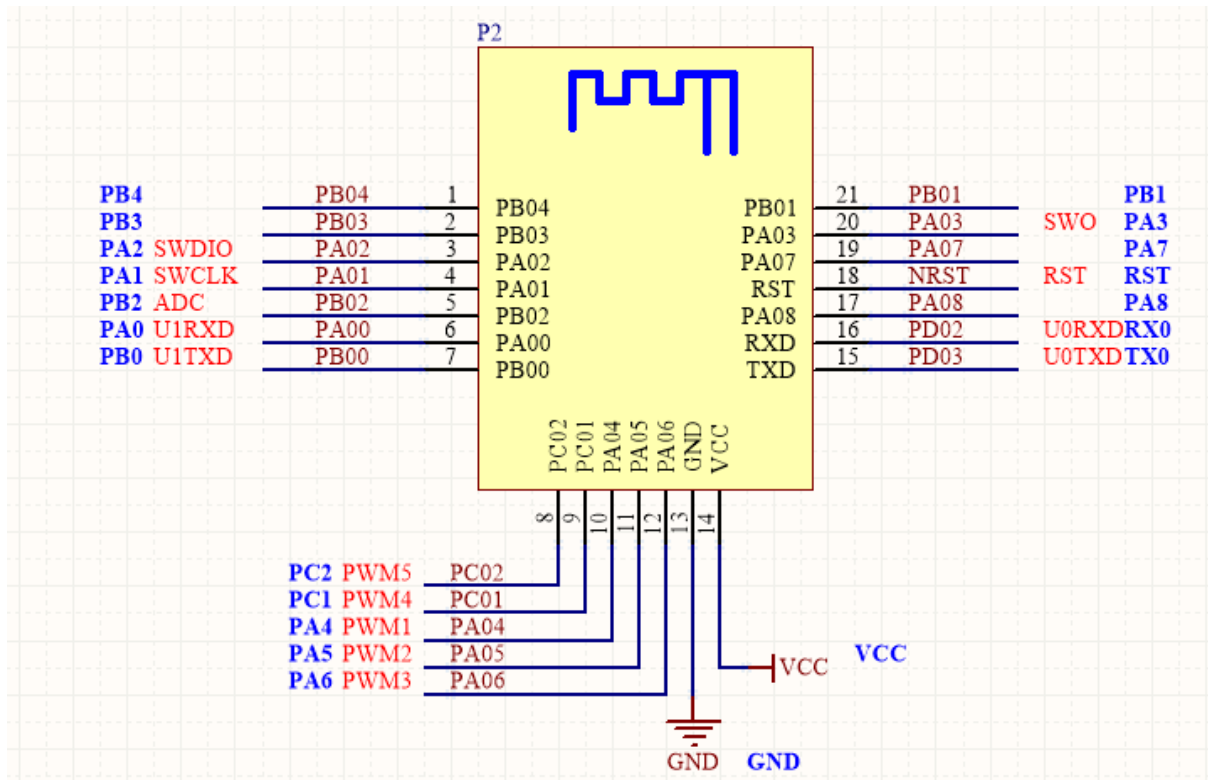

6.4 Recommended footprint

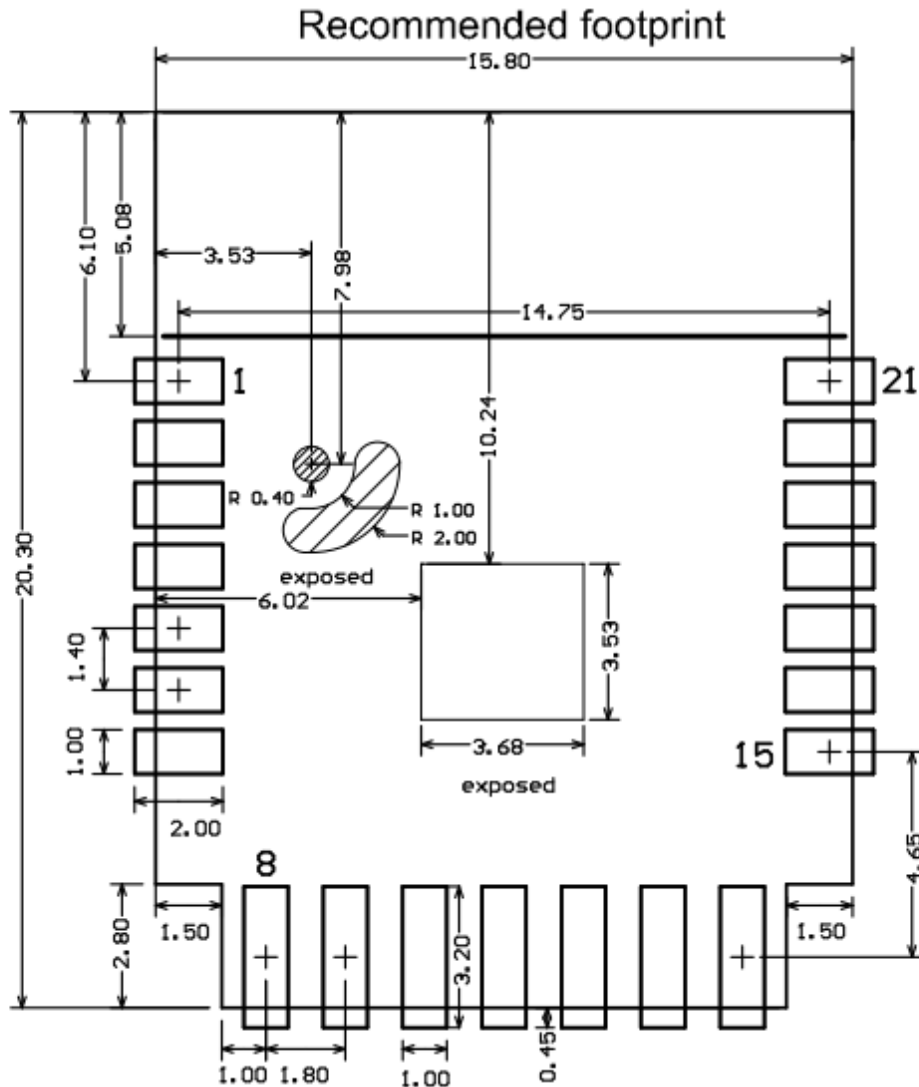

6.5 Production instructions

1. For the modules that can be packaged with the surface-mount technology (SMT) or in in-line form, you can select either of them according to the PCB design solutions of customers. If a PCB is designed to be SMT-packaged, package the module with the SMT. If a PCB is designed to use an in-line package, use wave soldering. Complete soldering within 24 hours after the module is

unpacked. Otherwise, we recommend that you place the module in a moisture-proof box with a relative humidity level below 10%, or pack the module in vacuum again. Then, record the packing time and duration of exposure. The total exposure time cannot exceed 168 hours.

- Instruments or devices required for the SMT process:
 - Surface mount system
 - SPI
 - Reflow soldering
 - Thermal profiler
 - Automated optical inspection (AOI) equipment
- Instruments or devices required for the wave soldering process:
 - Wave soldering equipment
 - Wave soldering fixture
 - Constant-temperature soldering iron
 - Tin bar, tin wire, and flux
 - Thermal profiler
- Instruments or devices required for the baking process:
 - Cabinet oven
 - Anti-electrostatic and heat-resistant trays
 - Anti-electrostatic and heat-resistant gloves

2. A delivered module must meet the following storage requirements:

- The moisture-proof bag must be placed in an environment where the temperature is below 40°C and the relative humidity is lower than 90%.
- The shelf life of a dry-packaged product is 12 months from the date when the product is packaged and sealed.
- A humidity indication card (HIC) is put in the sealed package.

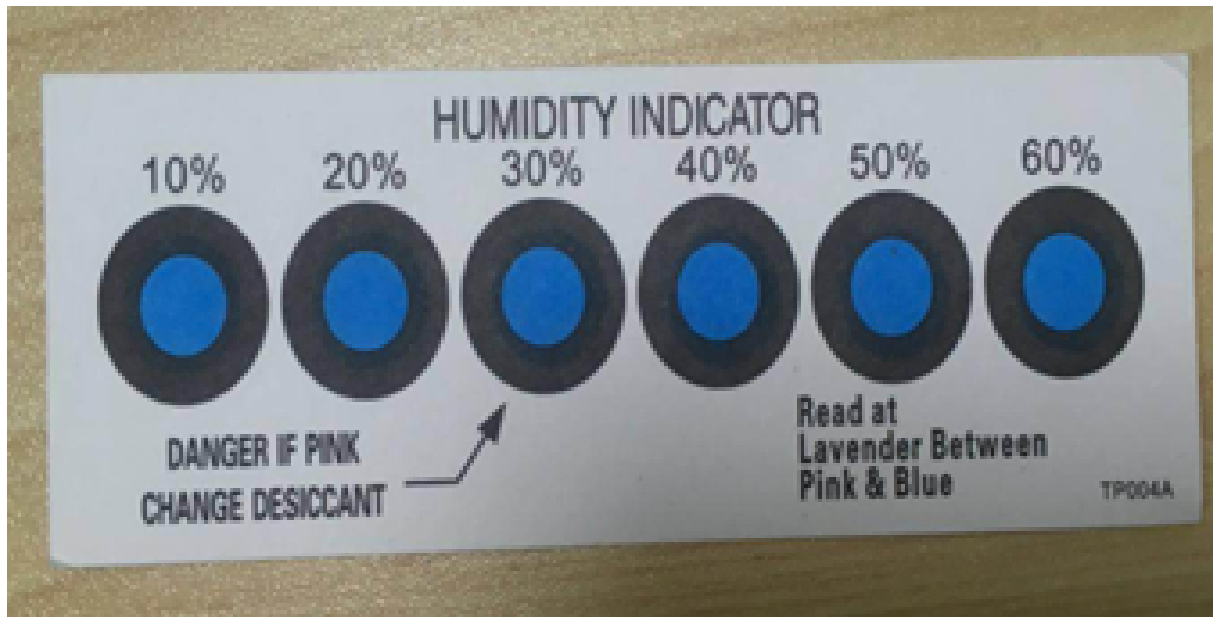

Figure 1: img

3. The module needs to be baked in the following cases:

- The vacuum packaging bag is damaged before unpacking.
- After unpacking, no HIC is found in the packaging bag.
- After unpacking, the HIC indicates a humidity level of 10% or higher. In this case, the circle turns pink on the HIC.
- The total exposure time has lasted for over 168 hours since unpacking.
- More than 12 months have passed since the first sealing of the bag.

4. The baking parameter settings are described below:

- Baking temperature: 40°C for reel packaging with relative humidity \leq 5%. And 125°C for tray packaging with relative humidity \leq 5% (use the heat-resistant tray, rather than plastic containers).
- Baking time: 168 hours for reel packaging and 12 hours for tray packaging.
- Temperature for triggering an alert: 50°C for reel packaging and 135°C for tray packaging.
- Production can begin after a module has cooled below 36°C under natural conditions.
- If a module remains unused for over 168 hours after being baked, it needs to be baked again.
- If a batch of modules is not baked after exposure for more than 168 hours,

do not use reflow soldering or wave soldering to solder them. Because these modules are level-3 moisture-sensitive devices, they are very likely to get damp when exposed beyond the allowable time. In this case, if they are soldered at high temperatures, device failure or poor soldering performance might occur.

5. In the whole production process, take electrostatic discharge (ESD) protective measures.
6. To guarantee the pass rate, we recommend that you use the SPI and AOI to monitor the quality of solder paste printing and mounting.
7. With a built-in crystal oscillator, this product can generally be cleaned with an ordinary detergent or ultrasonic wave. However, in some cases, vibrations generated by an ultrasonic cleaner can damage the internal structure of the crystal oscillator. If you use an ultrasonic cleaner, you need to verify in advance that the crystal oscillator inside the module is protected from any possible damage.
8. During product installation or processing, ultrasonic soldering is not recommended, because it might lead to excessive internal vibration or even failure of the crystal oscillator in the module.

6.6 Recommended oven temperature curve

Select a proper soldering technique according to the process. For the SMT process, refer to the recommended oven temperature curve of reflow soldering. For the wave soldering process, refer to the recommended oven temperature curve of wave soldering. The set temperatures might deviate from the actual temperature measurements. All temperatures shown in this module datasheet are obtained through actual measurements.

Technique 1: SMT process (recommended oven temperature curve of reflow soldering)

Set the oven temperatures according to the following curve.

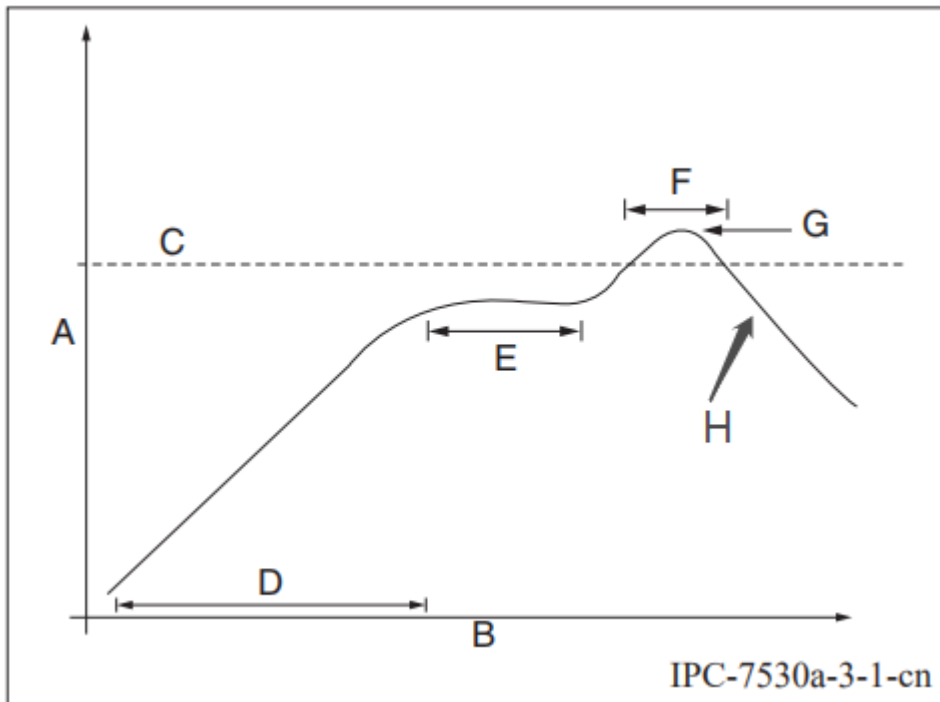

- A: temperature axis
- B: time axis
- C: alloy liquidus temperature from 217°C to 220°C
- D: ramp-up slope from 1°C/s to 3°C/s
- E: keep a constant temperature from 150°C to 200°C for a time period of 60s to 120s
- F: temperature above liquidus temperature for 50s to 70s
- G: peak temperature from 235°C to 245°C
- H: ramp-down slope from 1°C/s to 4°C/s

:::important

The curve above is based on solder paste SAC305. For more information about other solder pastes, see the recommended oven temperature curve in the specified solder paste specifications.

:::

Technique 2: Wave soldering process (oven temperature curve of wave soldering)

Set the oven temperatures according to the following temperature curve of wave soldering. The peak temperature is $260^{\circ}\text{C} \pm 5^{\circ}\text{C}$.

DIP Type Product Pass Wavesolder Graph

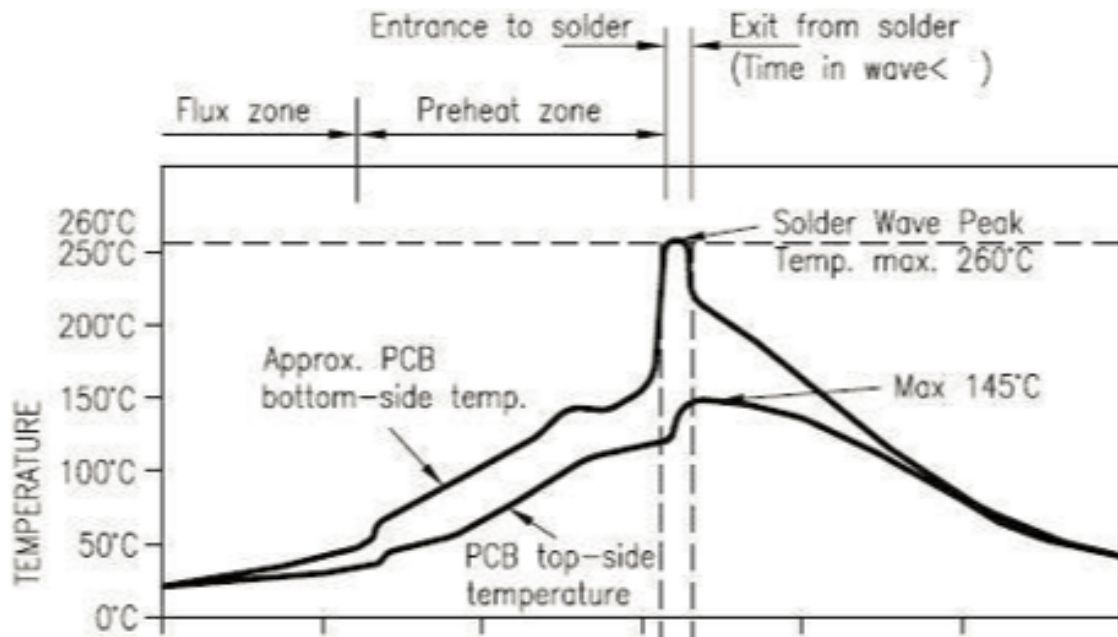

Suggestions on wave soldering

Suggestions on manual soldering

Preheat temperature	80°C to 130°C		
Soldering temperature	360°C ± 20°C		
Preheat duration	75s to 100s		
Soldering duration	Less than 3s/point		
Contact duration at the peak	3s to 5s	N/A	N/A
Solder tank temperature	260 ± 5°C	N/A	N/A
Ramp-up slope	≤ 2°C/s	N/A	N/A

Suggestions on wave soldering	Suggestions on manual soldering	
Ramp-down slope $\leq 6^{\circ}\text{C/s}$	N/A	N/A

6.7 Storage conditions



Caution
This bag contains
MOISTURE-SENSITIVE DEVICES

LEVEL
3

If blank, see adjacent bar code label

1. Calculated shelf life in sealed bag: 12 months at $<40^{\circ}\text{C}$ and $<90\%$ relative humidity (RH)
2. Peak package body temperature: 260 $^{\circ}\text{C}$
If blank, see adjacent bar code label
3. After bag is opened, devices that will be subjected to reflow solder or other high temperature process must be
 - a) Mounted within: 168 hours of factory conditions
If blank, see adjacent bar code label
 $\leq 30^{\circ}\text{C}/60\%$ RH, or
 - b) Stored per J-STD-033
4. Devices require bake, before mounting, if:
 - a) Humidity Indicator Card reads $>10\%$ for level 2a - 5a devices or $>60\%$ for level 2 devices when read at $23 \pm 5^{\circ}\text{C}$
 - b) 3a or 3b are not met
5. If baking is required, refer to IPC/JEDEC J-STD-033 for bake procedure

Bag Seal Date: _____
If blank, see adjacent bar code label

Note: Level and body temperature defined by IPC/JEDEC J-STD-020

7 MOQ and packaging information

Product model	MOQ (pcs)	Shipping packaging	Modules per reel (pcs)	Reels per carton
BS24-U	4400	Tape and reel	1100	4

8 Appendix: Statement

FCC Caution: Any changes or modifications not expressly approved by the party responsible for compliance could void the user's authority to operate this device. The module is limited to installation in mobile or fixed applications. This device complies with Part 15 of the FCC Rules. Operation is subject to the following two conditions: (1) This device may not cause harmful interference, and (2) this device must accept any interference received, including interference that may cause undesired operation.

Note: This device has been tested and found to comply with the limits for a Class B digital device, according to part 15 of the FCC Rules. These limits are designed to provide reasonable protection against harmful interference in a residential installation. This device generates, uses, and can radiate radio frequency energy and, if not installed and used following the instructions, may cause harmful interference to radio communications. However, there is no guarantee that interference will not occur in a particular installation.

If this device does cause harmful interference to radio or television reception, which can be determined by turning the device off and on, the user is encouraged to try to correct the interference by one or more of the following measures:

- Reorient or relocate the receiving antenna.
- Increase the separation between the device and receiver.
- Connect the device to an outlet on a circuit different from that to which the receiver is connected.
- Consult the dealer or an experienced radio/TV technician for help.

Radiation Exposure Statement

This device complies with FCC radiation exposure limits set forth for an uncontrolled rolled environment. This device should be installed and operated with a minimum distance of 20cm between the radiator and your body. The OEM integrator is responsible for ensuring that the end-user has no manual instructions to remove or install the module.

Important Note

This radio module must not be installed to co-locate and operate simultaneously with other radios in the host system except by following FCC multi-transmitter product procedures. Additional testing and device authorization may be required to operate simultaneously with other radios.

The availability of some specific channels and/or operational frequency bands are country-dependent and are firmware programmed at the factory to match the intended destination. The firmware setting is not accessible to the end-user.

The host product manufacturer is responsible for compliance with any other FCC rules that apply to the host not covered by the modular transmitter grant of certification. The final host product still requires Part 15 Subpart B compliance testing with the modular transmitter installed. Separate approval is required for all other operating configurations including portable configurations with respect to Part 2.1093 and different antenna configurations.

The end-user manual shall include all required regulatory information/warnings as shown in this manual, including “This product must be installed and operated with a minimum distance of 20 cm between the radiator and user body” .

This device has got an FCC ID: 2ANDL-BS24-U. The end product must be labeled in a visible area with the following: “Contains Transmitter Module FCC ID: 2ANDL-BS24-U” .

This device is intended only for OEM integrators under the following conditions:

The antenna must be installed such that 20cm is maintained between the antenna and users, and the transmitter module may not be co-located with any other transmitter or antenna.

As long as the 2 conditions above are met, further transmitter tests will not be required. However, the OEM integrator is still responsible for testing their end product for any additional compliance requirements required with this module installed.

Declaration of Conformity European Notice



Hereby, Hangzhou Tuya Information Technology Co., Ltd declares that this module product is in compliance with essential requirements and other relevant provisions of Directive 2014/53/EU,2011/65/EU. A copy of the Declaration of Conformity can be found at <https://www.tuya.com>.



This product must not be disposed of as normal household waste, in accordance with the EU directive for waste electrical and electronic equipment (WEEE-2012/19/EU). Instead, it should be disposed of by returning it to the point of sale, or to a municipal recycling collection point.

The device could be used with a separation distance of 20cm from the human body.