

TYWE1S-IPEX UserManual

1. Product Overview

TYWE1S-IPEX is a low power consumption module with built-in Wi-Fi connectivity solution designed by Hangzhou AiXiangJi Technology Co., Ltd. The Wi-Fi Module consist a highly integrated wireless radio chip ESP8266EX and extra flash which has been programed with Wi-Fi network protocol and plenty of software examples. TYWE1S also has an 32-bit CPU, 1M byte flash, 36k SRAM and various peripheral resources.

TYWE1S-IPEX is a RTOS platform, embedded with all the Wi-Fi MAC and TCP/IP protocol function examples, users can customize their Wi-Fi product by using these software examples.

Figure 1 shows the block diagram of the TYWE1S-IPEX.

Figure 1. The block diagram of theTYWE1S-IPEX

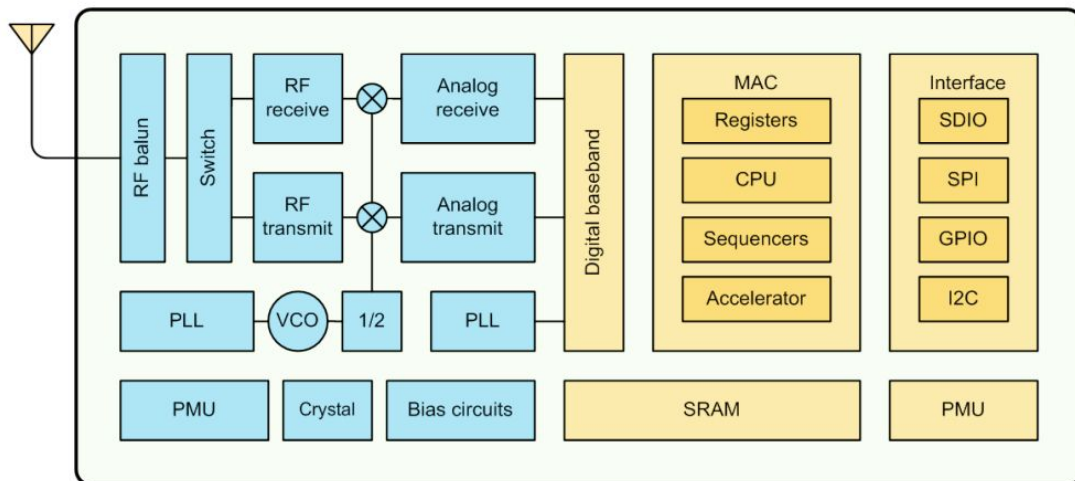

1.1 Features

- ✧ Integrated low power consumption 32-bit CPU, also known as application processor
 - Basic frequency can support both 80MHz and 160MHz
- ✧ Supply voltage range: 3V to 3.6V
- ✧ Peripherals: 6×GPIOs, 1×UART , 1×ADC
- ✧ Wi-Fi connectivity:
 - 802.11 b/g/n20
 - Channel 1 to 11 @ 2412-2462MHz
 - Support WPA/WPA2
 - 15.5dBm peak output power in 802.11b mode
 - Support STA/AP/STA+AP operation mode
 - Support Smart Link function for both Android and iOS devices
 - Standby power consumption is less than 0.1 mW (DTIM3)
 - On-board PCB antenna, or IPEX connector for external antenna

- CE, FCC certified
- Operating temperature range: 0 °C to 70 °C (Commercial grade), -40 °C to 85 °C (Industrial grade)

1.2 Main Application Fields

- ✧ Intelligent Building
- ✧ Intelligent home, Intelligent household applications
- ✧ Health care
- ✧ Industrial wireless control
- ✧ Baby monitor
- ✧ Webcam
- ✧ Intelligent bus

2. Dimensions and Footprint

2.1 Dimensions

TYWE1S-IPEX has 2 columns of Pins (2*9). The distance between each Pin is 1.5mm. Size of TYWE1S: 18mm(W)*23.5mm(L)*4.1mm(H)

Figure 2 shows the dimensions of TYWE1S-IPEX.

Figure 2. The dimensions of TYWE1S-IPEX

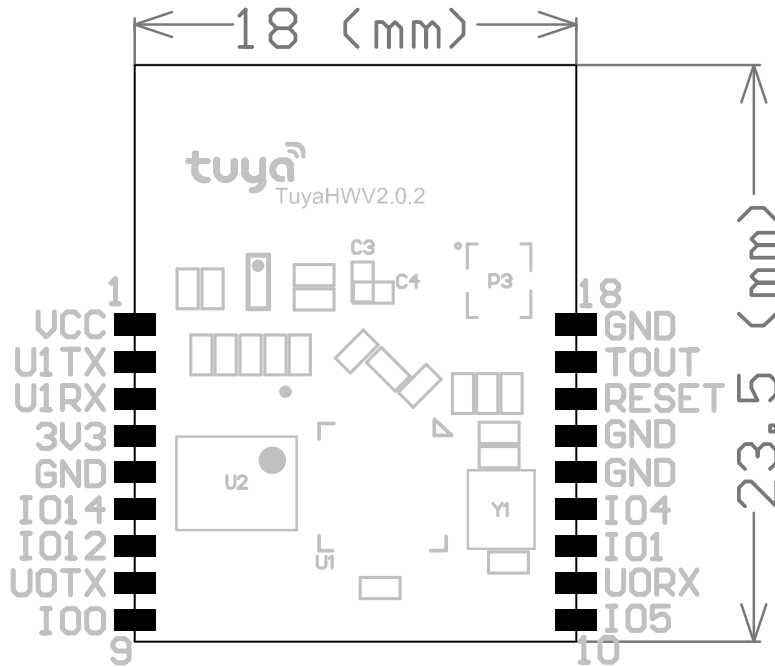

2.2 Pin Definition

Table 1 shows the general pin attributes of TYWE1S-IPEX

Table 1. The typical pin definition of TYWE1S-IPEX

PIN NO.	NAME	TYPE	DESCRIPTION
1	VCC	S	UART1 power (3.3V)
2	U1TX	I/O	UART1_TXD
3	U1RX	I/O	UART1_RXD
4	3V3	S	Supply voltage (3.3V)
5	GND	S	Ground
6	IO14	I/O	GPIO_14
7	IO12	I/O	GPIO_12
8	U0TX	I/O	UART0_TXD(used to print module's internal information)
9	IO0	I/O	GPIO_0(processing during initials, caution when used)
10	IO5	I/O	GPIO_5
11	U0RX	I/O	UART0_RXD(used to print module's internal information)

12	IO1	I/O	GPIO_1(status is uncertain during initials)
13	IO4	I/O	GPIO_4
14	GND	S	Ground
15	GND	S	Ground
16	RESET	I/O	External reset singal(negative level effects)
17	TOUT	AI	ADC terminal
18	GND	S	Ground

Note: S: Power supply pins; I/O: Digital input or output pins; AI: Analog input.

3. Electrical Characteristics

3.1 Absolute Maximum Ratings

Table 2. Absolute Maximum Ratings

PARAMETERS	DESCRIPTION	MIN	MAX	UNIT	
T _s	Storage temperature	-40	125	°C	
VDD	Supply voltage	3.0	3.6	V	
Electrostatic release quantity (Human body model)		TAMB-25°C	-	2	KV
Electrostatic release quantity (Machine model)		TAMB-25°C	-	0.5	KV

3.2 Electrical Conditions

Table 3. Electrical Conditions

PARAMETERS	DESCRIPTION	MIN	TYPICAL	MAX	UNIT
T _a	Temperature for Commercial grade	-30	-	70	°C
	Temperature for Industrial grade	-40	-	85	°C
VDD	Supply voltage	3.0	3.3	3.6	V
V _{IL}	IO negative level input	-0.3	-	3V3*0.25	V
V _{IH}	IO positive level input	3V3*0.75	-	3.6	V
V _{OL}	IO negative level output	-	-	3V3*0.1	V
V _{IH}	IO positive level output	3V3*0.8	-	-	V
I _{max}	IO drive current	-	-	12	mA
C _{pad}	Capacitance of the input pin	-	2	-	pF

3.3 Wi-Fi Transmitting Current Consumption

Table 4. Wi-Fi TX current consumption

PARAMETERS	MODE	RATE	TYPICAL	UNIT
IRF	11b	1Mbps	170	mA
IRF	11g	6Mbps	140	mA
IRF	11n20	MCS0	140	mA

3.4 Wi-Fi Receiving Current Consumption

Table 5. Wi-Fi RX current consumption

PARAMETERS	MODE	RATE	TYPICAL	UNIT
IRF	11b	1Mbps	50	mA
IRF	11g	6Mbps	56	mA
IRF	11n20	MCS0	56	mA

3.5 Working Mode Current Consumption

Table 6. MCU working current consumption

WORK MODE	CONDITION	TYPICAL	UNIT
Modem-Sleep	CPU is processing, Wi-Fi modem turns off	15	mA
Light-Sleep	CPU stops processing, Wi-Fi modem turns off	0.9	mA
Deep-Sleep	CPU stops processing, Wi-Fi modem turns off, Wi-Fi disconnects	10	μ A
Power Off	Power off	0.5	μ A

4. WLAN Radio Specification

4.1 Basic Radio Frequency Characteristics

Table 7. Basic Radio frequency characteristics

PARAMETERS	DESCRIPTION
Frequency band	2412MHz to 2462MHz
Wi-Fi standard	IEEE 802.11n20/g/b (Terminal 1-11)
Data transmitting rate	11b:1,2,5.5,11(Mbps)
	11g:6,9,12,18,24,36,48,54(Mbps)
	11n20:HT20,MCS0~7
Antenna type	On-board PCB Antenna (Default)
	U.FL RF external antenna

4.2 Wi-Fi Transmitting Power

Table 8. Wi-Fi transmitting power

PARAMETERS		MIN	TYPICAL	MAX	UNIT
RF peak output power, 802.11b CCK Mode	1M	-	15.5	-	dBm
RF peak output power, 802.11g OFDM Mode	6M	-	14	-	dBm
RF peak output power, 802.11n20 OFDM Mode	MCS0	-	14	-	dBm
The Frequency error		-10	-	10	ppm

4.3 Wi-Fi Receiving Sensitivity

Table 9. Wi-Fi Receiving sensitivity

PARAMETERS		MIN	TYPICAL	MAX	UNIT
PER<8%, Receiving sensitivity, 802.11b CCK Mode	1M	-	-91	-	dBm
PER<10%, Receiving sensitivity, 802.11g OFDM Mode	6M	-	-75	-	dBm
PER<10%, Receiving sensitivity, 802.11n20 OFDM Mode	MCS0	-	-72	-	dBm

5. Antenna Information

5.1 Antenna Type

Antenna can be connected using On-board PCB antenna or an external antenna, the default way is using the On-board PCB antenna.

User can modify the connection mode shown below: (TYWE1S has a resistance--00mh/0402 marked as red)

Figure 3. On-board PCB Antenna configuration

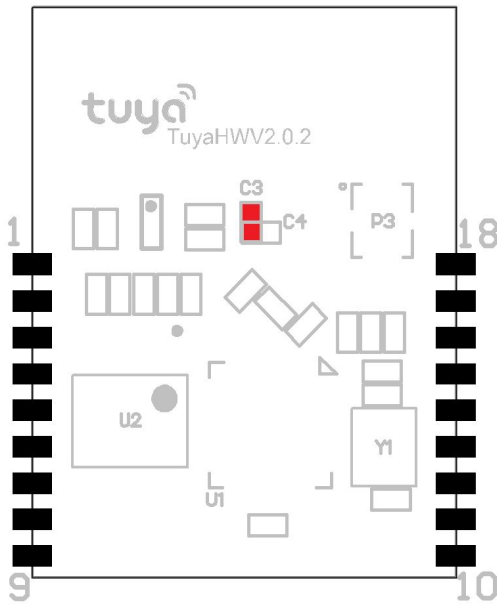
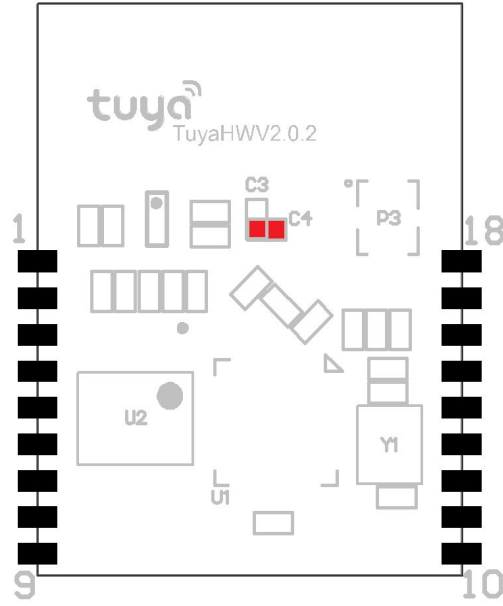

Figure 4. External Antenna configuration



5.2 Reduce Antenna Interference

While using the On-board PCB antenna, in order to have the best Wi-Fi performance, it's recommended to keep a minimum 20mm distance between the antenna part and the other metal pieces.

5.3 U.FL RF Connector

Figure 5 shows the physical parameter of the U.FL RF connector.

Figure 5. The physical parameter of the U.FL RF connector

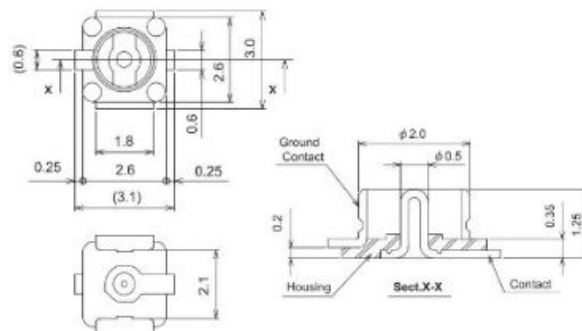

6. Packaging Information And Production Guide

6.1 Mechanical Dimensions

Figure 6. Top view of the module

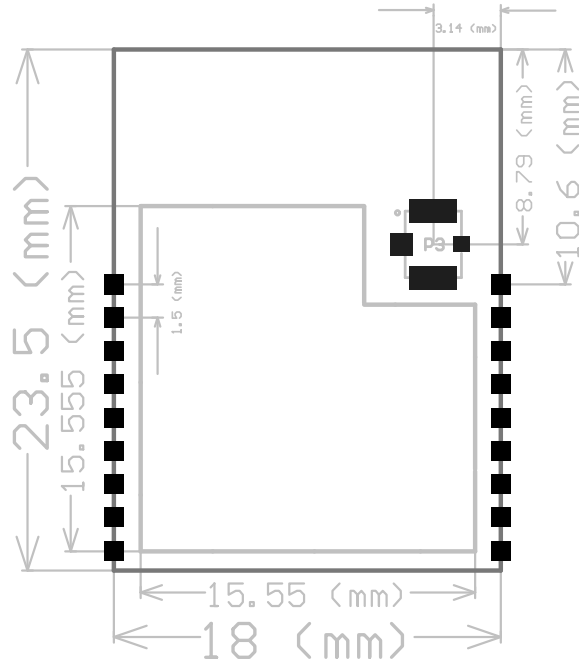
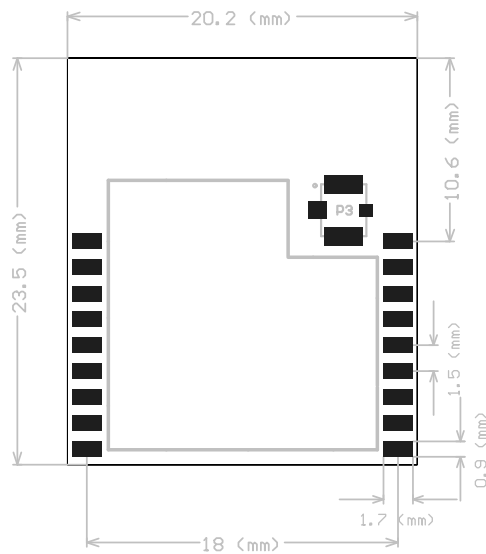

Figure 7. Side view of the module



6.2 PCB Recommended Package

Figure 8. PCB Package Drawing



6.3 Production Guide

- ◇ The storage for the delivered module should meet the following condition:
 1. The anti-moisture bag should be kept in the environment with temperature $< 30^{\circ}\text{C}$ and humidity $< 85\%$ RH.
 2. The expiration date is 6 months since the dry packaging products was sealed.
- ◇ Cautions:
 1. All the operators should wear electrostatic ring in the whole process of production.
 2. While operating, water and dirt should not have any contact with the modules.

6.4 Suggested Reflow Profile

Refer to IPC/JEDEC standard ; Peak Temperature : $< 250^{\circ}\text{C}$; Number of Times : ≤ 2 times ;

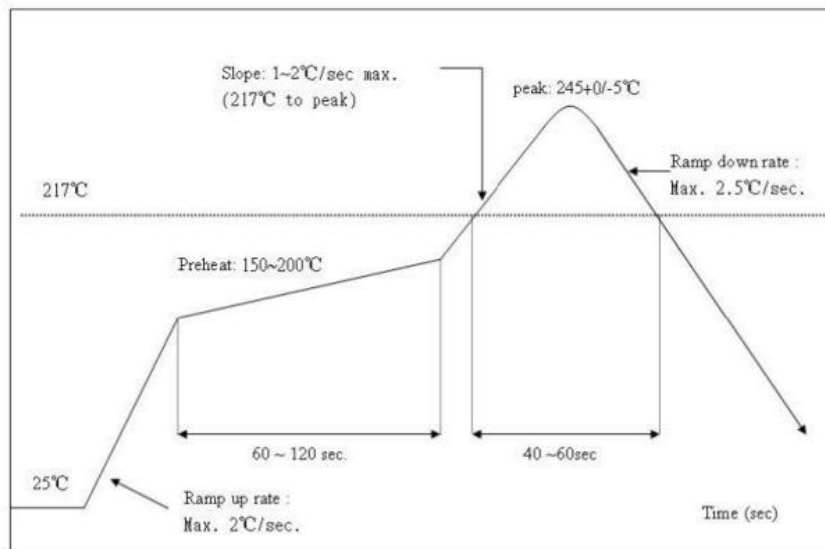

FCC Warning

Any Changes or modifications not expressly approved by the party responsible for compliance could void the user's authority to operate the equipment.

This device complies with part 15 of the FCC Rules. Operation is subject to the following two conditions: (1) This device may not cause harmful interference (2) this device must accept any interference received, including interference that may cause undesired operation.

FCC Radiation Exposure Statement:

This equipment complies with FCC radiation exposure limits set forth for an uncontrolled environment .This equipment should be installed and operated with minimum distance 20cm between the radiator& your body.

FCC Label Instructions

The outside of final products that contains this module device must display a label referring to the enclosed module. This exterior label can use wording such as: "Contains Transmitter Module FCC ID:2ANDL-TYWE1S or Contains FCC ID:2ANDL-TYWE1S" , any similar wording that expresses the same meaning may be used.