

happiest  baby

# snoo

smart sleeper®



**USER GUIDE**

# TABLE OF CONTENTS

<b>SNOO: SAFER. BETTER. SLEEP.....</b>	<b>2</b>
<b>GETTING STARTED .....</b>	<b>3</b>
<b>WHAT'S INCLUDED .....</b>	<b>3</b>
<b>SETTING UP SNOO .....</b>	<b>4</b>
<b>USING THE SNOO SACK .....</b>	<b>5</b>
<b>TURNING SNOO ON .....</b>	<b>6</b>
<b>CONNECTING SNOO TO THE INTERNET .....</b>	<b>7</b>
<b>SPECIFICATIONS .....</b>	<b>8</b>
<b>SAFETY INFORMATION .....</b>	<b>9-10</b>
<b>CARE INFORMATION .....</b>	<b>11</b>
<b>LIMITED WARRANTY .....</b>	<b>12-13</b>
<b>COMPLIANCE NOTICE .....</b>	<b>13</b>
<b>END USER LICENSE .....</b>	<b>14-17</b>
<b>SNOO ACCESSORIES.....</b>	<b>18</b>
<b>CONTACT .....</b>	<b>19</b>

## **SNOO ACCESSORIES**

### **SNOO Sack (Small, Medium, Large)**

- Made with GOTS certified organic cotton.
- The 5-Second Swaddle™ makes baby wrapping fast, easy and safer.

### **SNOO Fitted Sheet**

- GOTS certified organic cotton.

### **SNOO Shorty Legs**

- To lower SNOO for parents using a platform bed.

**These and other SNOO accessories are available at [www.happiestbaby.com](http://www.happiestbaby.com)**

## END USER LICENSE CONT.

11. *For U.S. Government End Users.* The Product Software is a “commercial item,” as that term is defined at 48 C.F.R. 2.101 (OCT 1995), and more specifically is “commercial computer software” and “commercial computer software documentation,” as such terms are used in 48 C.F.R. 12.212 (SEPT 1995). Consistent with 48 C.F.R. 12.212 and 48 C.F.R. 227.7202-1 through 227.7202-4 (JUNE 1995), the Product Software is provided to U.S. Government End Users only as a commercial end item and with only those rights as are granted to all other customers pursuant to the terms and conditions herein.
12. *Export Compliance.* The Product Software and related technology are subject to U.S. export control laws and may be subject to export or import regulations in other countries. You agree to strictly comply with all such laws and regulations and acknowledge that you have the responsibility to obtain authorization to export, re-export, or import the Product Software and related technology, as may be required. You will indemnify and hold HBI harmless from any and all claims, losses, liabilities, damages, fines, penalties, costs and expenses (including attorney’s fees) arising from or relating to any breach by you of your obligations under this section.
13. *Governing Law; Venue.* The courts in some countries will not apply California law to some types of disputes. If you reside in one of those countries, then where California law is excluded from applying, your country’s laws will apply to such disputes related to these terms. Otherwise, you agree that this EULA, and any claim, dispute, action, cause of action, issue, or request for relief relating to this EULA, will be governed by the laws of California, without giving effect to any conflicts of laws principles that require the application of the laws of a different jurisdiction. Any action or proceeding relating to this EULA must be brought in a federal or state court located in Los Angeles County, California and each party irrevocably submits to the jurisdiction and venue of any such court in any such claim or dispute, except that HBI may seek injunctive relief in any court having jurisdiction to protect its intellectual property or Confidential Information.
14. *Assignment.* Neither the rights nor the obligations arising under this EULA are assignable by you, and any such attempted assignment shall be void and without effect.
15. *Notices.* Any notice to you may be provided by email to the address that you registered with HBI.
16. *Severability.* If any provision of this EULA is unenforceable, such provision will be changed and interpreted to accomplish the objectives of such provision to the greatest extent possible under applicable law and the remaining provisions will continue in full force and effect.
17. *Waiver.* All waivers by HBI will be effective only if in writing. Any waiver or failure by HBI to enforce any provision of this EULA on one occasion will not be deemed a waiver of any other provision or of such provision on any other occasion.
18. *General.* The Product Software is deemed irrevocably accepted upon your use of the Product Software or Product. HBI will have no responsibility to provide maintenance or support services with respect to the Product Software. The parties are independent contractors. You acknowledge that the Product Software contains valuable trade secrets and proprietary information of HBI, that any actual or threatened breach of Section 2 (Restrictions) of this EULA will constitute immediate, irreparable harm to HBI for which monetary damages would be an inadequate remedy, and that injunctive relief is an appropriate remedy for such breach.  
The headings of Sections of this EULA are for convenience and are not to be used in interpreting this EULA. Except as otherwise provided in this section, no amendment to this EULA will be valid unless it is in writing hand-signed by the parties.
19. *Questions or Additional Information.* If you have any questions regarding this EULA, please visit us at [www.happiestbaby.com/customer-care](http://www.happiestbaby.com/customer-care).

## **SNOO: SAFER. BETTER. SLEEP - at the touch of a button.**

Almost every aspect of life has been revamped and rebooted over the past decade. Yet, as crazy as it sounds, baby beds haven't changed in over 1000 years! Today's bassinets and cribs are just boring little "boxes" to safely store babies - away from curious toddlers or the family dog.

Unfortunately, babies don't sleep well on flat, still beds in totally quiet rooms. In fact, over 50% of babies still wake up once a night after 6 long months. That's a problem because poor baby sleep causes the #1 new parent stress: EXHAUSTION!

Sleep deprivation is grueling. And, it can trigger serious problems, like marital fights, failed nursing, anxiety, depression, accidents, even make it hard to lose that baby weight.

Besides exhaustion, today's parents struggle because they have little or no help at home. Think that's normal? Think again! Most parents - through human history - had 3-4 "nannies" to help them! (You know, their mom, grandma, cousin, friends, neighbor's older daughter).

Many moms and dads turn to bed sharing as the only way they can get their infant to sleep. Yet, tragically, 1000's of babies die each year from rolling over or sleeping in a bed with a tired adult.

Bottom line: Our babies need safer, better sleep...and new moms and dads need it, too.

That's why we created SNOO!

My dream was to mix ancient wisdom + top science to make a bed for 21<sup>st</sup> century babies. It's based on the discovery that babies sleep better with soothing rhythms of the womb, called the 5 S's (described in my DVD/book, *The Happiest Baby on the Block*.) Then, together with MIT engineers and the nation's top designer, we built SNOO, the world's 1<sup>st</sup> smart sleeper.

- SNOO gives a perfect 4<sup>th</sup> trimester of gentle shushing and rocking...all night long. And, it quickly responds to your babies' fussies with stronger sound and jiggly motion (safely moving your baby less than an inch...back and forth).
- SNOO helps most new babies on the very first day. Older babies (2+ months) may need 4-5 days to get used to the new sensations. (Visit [happiestbaby.com](http://happiestbaby.com) to learn how to help your baby fall in love with SNOO.)
- If your baby's crying calms fast, your job is done. (Put your head back on the pillow!) However, if fussing continues - despite SNOO's response - you'll know that your little one needs YOU! (Now, it's your turn to offer some milk, a diaper or just a sweet cuddle.)
- When your baby gets older, the SNOO app automatically weans her off the motion.
- SNOO is the safest baby bed...ever. Zip your baby into the SNOO Sack, attach it to the clips and you'll never again have that 2 a.m panic, "Did my baby roll over?!"
- Soon, your baby will be more awake in the day and snoo-zing more at night. And, better baby sleep will lead to a happier, healthier, better rested child in the early years.

Thanks for letting *Happiest Baby* help you help your family during this magical journey!



Dr. Harvey Karp

# GETTING STARTED

- Read all instructions before assembly and use of this product.
- Keep instructions for future reference.
- Recommended for infants until they can push up on hands and knees, or at six months, whichever comes first.
- No tools or batteries needed.
- SNOO is not a replacement for responsible, attentive care or medical assistance.

# WHAT'S INCLUDED

- A. SNOO Bed
- B. Legs (4)
- C. Power Adapter
- D. Power Cable Holder (attached to leg)
- E. SNOO Sacks (1 Medium & 1 Large) (made with GOTS certified organic cotton)
- F. SNOO Sack (1 Small) (attached to safety clips)
- G. Mattress
- H. Fitted Sheet (made with GOTS certified organic cotton)

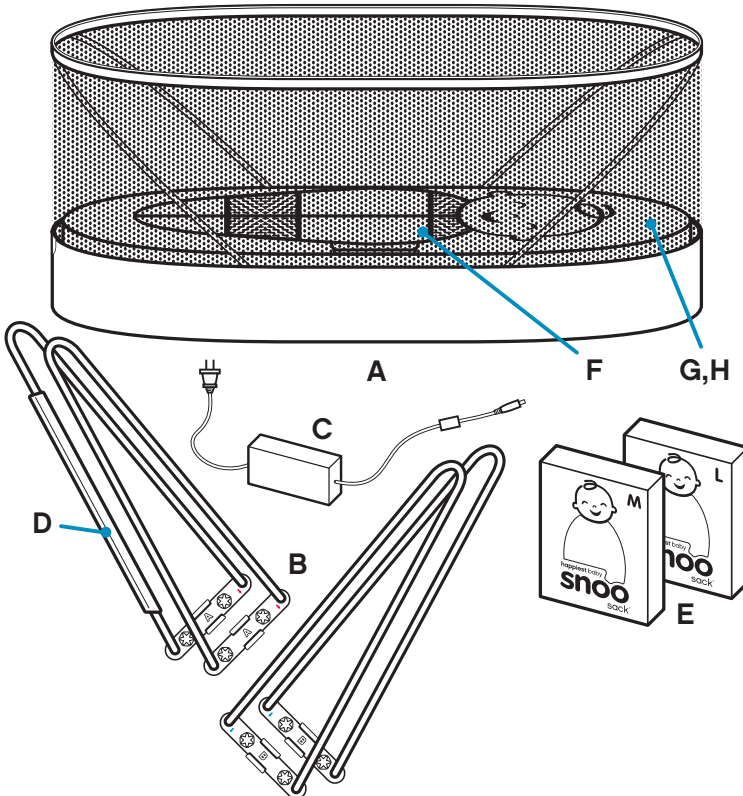

## END USER LICENSE CONT.

8. *Limitation of Liability.* Nothing in this EULA and in particular within this “Limitation of Liability” clause shall attempt to exclude liability that cannot be excluded under applicable law.

TO THE MAXIMUM EXTENT PERMITTED BY APPLICABLE LAW, IN ADDITION TO THE ABOVE WARRANTY DISCLAIMERS, IN NO EVENT WILL (A) HBI BE LIABLE FOR ANY CONSEQUENTIAL, EXEMPLARY, SPECIAL, OR INCIDENTAL DAMAGES, INCLUDING ANY DAMAGES FOR LOST DATA OR LOST PROFITS, ARISING FROM OR RELATING TO THE PRODUCTS OR PRODUCT SOFTWARE, EVEN IF HBI KNEW OR SHOULD HAVE KNOWN OF THE POSSIBILITY OF SUCH DAMAGES, AND (B) HBI' TOTAL CUMULATIVE LIABILITY ARISING FROM OR RELATED TO THE PRODUCTS AND PRODUCT SOFTWARE, WHETHER IN CONTRACT OR TORT OR OTHERWISE, EXCEED THE FEES ACTUALLY PAID BY YOU TO HBI OR HBI'S AUTHORIZED RESELLER FOR THE PRODUCT AT ISSUE IN THE PRIOR 12 MONTHS (IF ANY). THIS LIMITATION IS CUMULATIVE AND WILL NOT BE INCREASED BY THE EXISTENCE OF MORE THAN ONE INCIDENT OR CLAIM. HBI DISCLAIMS ALL LIABILITY OF ANY KIND OF HBI' LICENSORS AND SUPPLIERS.

9. *Limitations of Product Software.* YOU ACKNOWLEDGE THAT THE PRODUCTS AND PRODUCT SOFTWARE ARE NOT A MEDICAL DEVICE OR AN EMERGENCY NOTIFICATION SYSTEM. HBI makes no warranty or representation that the use of the Products or Product Software (with or without any third-party product or service) constitutes medical treatment. You understand and acknowledge that HBI's Products or Product Software will not dispatch emergency authorities in the event of an emergency. Furthermore, HBI's Customer Care and Support contacts cannot be considered a medical resource. If you have an emergency or a medical concern, it is your responsibility to seek medical assistance.

The Product Software provides you information (“Product Information”) regarding your baby. All Product Information is provided “as is” and “as available”. We cannot guarantee that it is correct or up to date. In cases where it is critical, accessing Product Information through the Product Software is not a substitute for direct access of the information in the home.

10. *Confidentiality.* “Confidential Information” shall mean the Product Software and all other information disclosed to you that HBI characterizes as confidential at the time of its disclosure either in writing or orally, except for information which you can demonstrate: (a) is previously rightfully known to you without restriction on disclosure; (b) is or becomes, from no act or failure to act on your part, generally known in the relevant industry or public domain; (c) is disclosed to you by a third party as a matter of right and without restriction on disclosure; or (d) is independently developed by you without access to the Confidential Information. You shall use your best efforts to preserve and protect the confidentiality of the Confidential Information at all times, both during the term hereof and for a period of at least 3 years after termination of this EULA, provided, however, that any source code you receive shall be held in confidence in perpetuity. You shall not disclose, disseminate or otherwise publish or communicate Confidential Information to any person, firm, corporation or other third party without the prior written consent of HBI. You shall not use any Confidential Information other than in the course of the activities permitted hereunder. You shall notify HBI in writing immediately upon discovery of any unauthorized use or disclosure of Confidential Information or any other breach of this EULA, and will cooperate with HBI in every reasonable way to regain possession of Confidential Information and prevent any further unauthorized use. If you are legally compelled to disclose any of the Confidential Information, then, prior to such disclosure, you will (i) immediately notify HBI prior to such disclosure to allow HBI an opportunity to contest the disclosure, (ii) assert the privileged and confidential nature of the Confidential Information, and (iii) cooperate fully with HBI in protecting against any such disclosure and/or obtaining a protective order narrowing the scope of such disclosure and/or use of the Confidential Information. In the event such protection is not obtained, you shall disclose the Confidential Information only to the extent necessary to comply with the applicable legal requirements.

## END USER LICENSE CONT.

3. *Automatic Software Updates.* HBI may from time to time develop patches, bug fixes, updates, upgrades and other modifications to improve the performance of the Product Software and related services (“Updates”). These may be automatically installed without providing any additional notice or receiving any additional consent. You consent to this automatic update. If you do not want such Updates, your remedy is to stop using the Product. If you do not cease using the Product, you will receive Updates automatically. You acknowledge that you may be required to install Updates to use the Product and the Product Software and you agree to promptly install any Updates HBI provides. Your continued use of the Product is your agreement to this EULA.
4. *Ownership.* The Product Software and all worldwide copyrights, trade secrets, and other intellectual property rights therein are the exclusive property of HBI and its licensors. HBI and its licensors reserve all rights in and to the Product Software not expressly granted to you in this EULA. The Product Software (and all copies thereof) is licensed to you, not sold, under this EULA. There are no implied licenses in this EULA. All suggestions or feedback provided by you to HBI with respect to the Product Software shall be HBI’ property. HBI may use, copy, modify, publish, or redistribute the submission and its contents for any purpose and in any way without any compensation to you. You also agree that HBI does not waive any rights to use similar or related ideas previously known to HBI, developed by its employees, or obtained from other sources.
5. *Open Source.* Certain items of software included with the Product Software are subject to “open source” or “free software” licenses (“Open Source Software”). Some of the Open Source Software is owned by third parties. The Open Source Software is not subject to the terms and conditions of this EULA. Instead, each item of Open Source Software is licensed under the terms of the end user license that accompanies such Open Source Software. Nothing in this EULA limits your rights under, or grants you rights that supersede, the terms and conditions of any applicable end user license for the Open Source Software. If required by any license for particular Open Source Software, HBI makes such Open Source Software, and HBI’ modifications to that Open Source Software, available by written request to HBI at the email or mailing address listed below.
6. *Term and Termination.* This EULA and the license granted hereunder are effective on the date you first use the Product Software or Product and shall continue for as long as you own the Product, unless this EULA is terminated under this section. HBI may terminate this EULA at any time if you fail to comply with any term(s) hereof. You may terminate this EULA effective immediately upon written notice to HBI. Upon termination of this EULA, the license granted hereunder will terminate and you must stop all use of the Product Software, but the terms of Sections 2 through 18 (inclusive) will remain in effect, after any such termination.
7. *Warranty Disclaimer.* NOTWITHSTANDING ANYTHING TO THE CONTRARY AND TO THE MAXIMUM EXTENT PERMITTED BY APPLICABLE LAW, HBI PROVIDES THE PRODUCT SOFTWARE “AS-IS” AND DISCLAIMS ALL WARRANTIES AND CONDITIONS, WHETHER EXPRESS, IMPLIED, OR STATUTORY, INCLUDING THE WARRANTIES OF MERCHANTABILITY, FITNESS FOR A PARTICULAR PURPOSE, TITLE, QUIET ENJOYMENT, ACCURACY, AND NON-INFRINGEMENT OF THIRD-PARTY RIGHTS. HBI DOES NOT GUARANTEE ANY SPECIFIC RESULTS FROM THE USE OF THE PRODUCT SOFTWARE. HBI MAKES NO WARRANTY THAT THE PRODUCT SOFTWARE WILL BE UNINTERRUPTED, FREE OF VIRUSES OR OTHER HARMFUL CODE, TIMELY, SECURE, OR ERROR-FREE. YOU USE ALL PRODUCT INFORMATION (AS DEFINED BELOW), THE PRODUCT SOFTWARE, AND THE PRODUCT AT YOUR OWN DISCRETION AND RISK. YOU WILL BE SOLELY RESPONSIBLE FOR (AND HBI DISCLAIMS) ANY AND ALL LOSS, LIABILITY, OR DAMAGES, INCLUDING TO YOUR HVAC SYSTEM, PLUMBING, HOME, PRODUCT, OTHER PERIPHERALS CONNECTED TO THE PRODUCT, COMPUTER, MOBILE DEVICE, AND ALL OTHER ITEMS AND PETS IN YOUR HOME, RESULTING FROM YOUR USE OF THE PRODUCT INFORMATION, PRODUCT SOFTWARE, OR PRODUCT.



# SETTING UP YOUR SNOO

- Remove all contents from box.
- Remove SNOO from the protective cloth bag. Turn it upside down on the bag or another clean surface.

**1** Insert each leg into base (match red and blue arrows on leg brackets to their corresponding colored arrows on base).

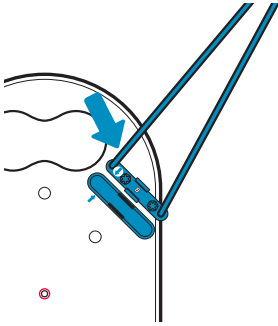

**2** Push leg into base until you hear a “click.”

**3** Hand tighten all bolts.

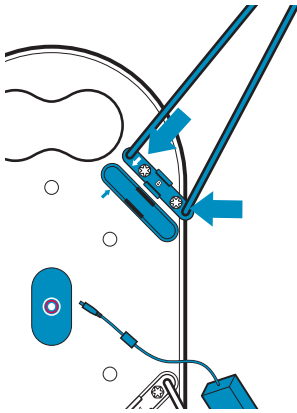

**4** Insert power adapter into socket in the middle of the bottom of base (there is a red circle around the socket).

**5** Now, place your SNOO on its four feet.

**6** Pull soft plastic power cable holder off leg. Insert it on leg that is closest to electric wall outlet.

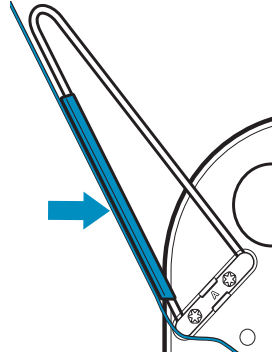

**7** Insert thin power cable into entire length of power cable holder.

**8** Plug power cord into electric outlet.

**9** The power button at the front of SNOO will flash on and off for a few seconds before becoming a constant white light.

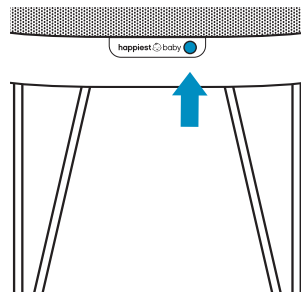

**10** SNOO is now ready to help you soothe and protect your baby.

## NOTE:

- ALWAYS keep SNOO on a flat, even surface (see “PREVENT STRANGULATION HAZARD” page 9).
- NEVER place anything under SNOO legs or mattress to elevate baby’s head (see “PREVENT STRANGULATION HAZARD” page 9).

# USING THE SNOO SACK

- Slide the small sleep sack and insert off the safety clips. Unzip and remove the small sleep sack. We recommend machine washing in warm water prior to use.
- Place the SNOO Sack on a flat surface.

**1** Unzip and open inner bands. Place baby inside the sack.

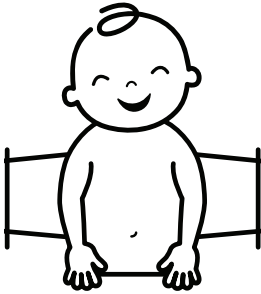

**3** Always close zipper fully..at top and bottom!

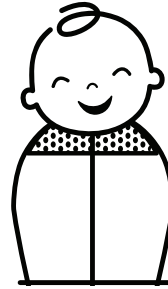

**2** Straighten the arms and snugly pull the inner bands around the baby. The ends of the inner bands will Velcro closed.

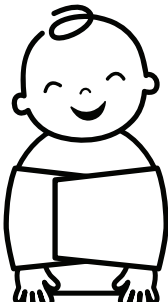

**4** Place baby in SNOO. (Put the feet at the end nearest to SNOO power button). Slide each elastic wing loop all the way on to each safety clip.

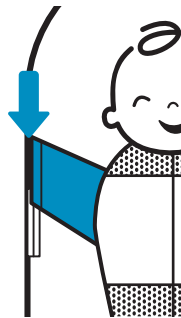

## NOTE:

- It is only safe to use the SNOO Sack with the zipper fully closed.
- To keep your baby's arms from popping out from the inner band, make sure the lower edge goes directly over your baby's hand.
- SNOO will not work unless you slide the elastic wing loops onto both safety clips.

# END USER LICENSE

By using the software (“Product Software”) that is embedded on the Happiest Baby, Inc. product (“Product”), you agree to the terms of this End User License Agreement (“EULA”) between you and Happiest Baby, Inc. (“HBI”, “we”, “us”, “our”). IF YOU DO NOT AGREE TO THE TERMS OF THIS EULA, YOU MAY NOT USE THE PRODUCT SOFTWARE AND YOU MAY CHOOSE TO PROMPTLY RETURN THE PRODUCT FOR A REFUND OF THE PRODUCT PURCHASE PRICE BY CONTACTING HBI AT THE ADDRESS BELOW. Your use of (a) the website located at [www.happiestbaby.com](http://www.happiestbaby.com) and our sub-domains (each, a “Site”), (b) services through the Site (and any updates thereto) (“Site Services”), and (c) certain software that may be downloaded to your mobile device (and any updates thereto) (“App”) is governed by the Terms of Service Your purchase of the Product (excluding the Product Software) is governed by the HBI limited warranty, the terms of which are provided with the Product. This EULA does not govern your use of the Site, Services, or App, or your purchase of the Product (excluding the Product Software).

This EULA governs your access and use of the Product Software. This EULA gives you specific legal rights, and you may also have other legal rights in addition, which vary from jurisdiction to jurisdiction. The disclaimers, exclusions, and limitations of liability under this EULA will not apply to the extent prohibited by applicable law. Some jurisdictions do not allow the exclusion of implied warranties or the exclusion or limitation of incidental or consequential damages or other rights, so those provisions of this EULA may not apply to you.

THIS IS A LEGAL AGREEMENT. BY ACCESSING AND USING THE PRODUCT SOFTWARE, YOU ARE ACCEPTING AND AGREEING TO THIS EULA ON BEHALF OF YOURSELF OR THE ENTITY YOU REPRESENT IN CONNECTION WITH THE ACCESS. YOU REPRESENT AND WARRANT THAT YOU HAVE THE RIGHT, AUTHORITY, AND CAPACITY TO ACCEPT AND AGREE TO THIS EULA ON BEHALF OF YOURSELF OR THE ENTITY YOU REPRESENT. YOU REPRESENT THAT YOU ARE OF SUFFICIENT LEGAL AGE IN YOUR JURISDICTION OR RESIDENCE TO USE OR ACCESS THE PRODUCT SOFTWARE AND TO ENTER INTO THIS EULA. IF YOU DO NOT AGREE WITH ANY OF THE PROVISIONS OF THESE TERMS, YOU SHOULD CEASE ACCESSING OR USING THE PRODUCT SOFTWARE.

AS DESCRIBED BELOW, YOU ARE CONSENTING TO AUTOMATIC SOFTWARE UPDATE OF THE PRODUCT SOFTWARE. IF YOU DO NOT AGREE, YOU SHOULD NOT USE THE PRODUCT SOFTWARE. AS DESCRIBED BELOW, SECTION 9 DESCRIBES IMPORTANT LIMITATIONS OF THE PRODUCT SOFTWARE AND RELATED SERVICES, ESPECIALLY IN CONNECTION WITH LIFE SAFETY AND CRITICAL USES. PLEASE READ THESE DISCLOSURES CAREFULLY, AS YOU ARE ACKNOWLEDGING THEM AND ACCEPTING THEM.

1. *License.* Subject to the terms of this EULA, HBI grants to you a limited and nonexclusive license (without the right to sublicense) to execute one (1) copy of the Product Software, in executable object code form only, solely on the Product that you own or control and solely for use in conjunction with the Product for your personal, non-commercial purposes.
2. *Restrictions.* You agree not to, and you will not permit others to, (a) license, sell, rent, lease, assign, distribute, transmit, host, outsource, disclose or otherwise commercially exploit the Product Software or make the Product Software available to any third party, (b) copy or use the Product Software for any purpose other than as permitted in Section 1, (c) use any portion of the Product Software on any device or computer other than the Product that you own or control, (d) remove or alter any trademark, logo, copyright or other proprietary notices, legends, symbols or labels in the Product Software, or (e) modify, make derivative works of, disassemble, reverse compile or reverse engineer any part of the Product Software (except to the extent applicable laws specifically prohibit such restriction for interoperability purposes, in which case you agree to first contact HBI and provide HBI an opportunity to create such changes as are needed for interoperability purposes). You may not release the results of any performance or functional evaluation of any of the Product Software to any third party without prior written approval of HBI for each such release.

# LIMITED WARRANTY CONT.

In addition to the above, this warranty also excludes:

- Defects due to normal wear and tear or aging, including soft goods;
- Damage due to improper repair, operation or maintenance or connections to improper voltage supply or, to the extent allowed by law, attempted repair by anyone other than a facility authorized by HBI to service your HBI product.
- Use of the Product for purposes other than for which the Product was designed or intended
- Misuse of product contrary to instructions provided by HBI (which may be provided at the time of purchase or on its website at <http://www.happiestbaby.com/customer-care>).
- Specific wireless signal or reception problems, internet connectivity issues of your router, or your smartphone.

## 9. Disclaimer of Warranties

TO THE FULLEST EXTENT PERMITTED BY LAW, THIS WARRANTY AND THE REMEDIES SET FORTH HEREIN ARE EXCLUSIVE AND IN LIEU OF ALL OTHER WARRANTIES, REMEDIES AND CONDITIONS, WHETHER ORAL, WRITTEN, STATUTORY, EXPRESS OR IMPLIED. HBI DISCLAIMS ALL STATUTORY AND IMPLIED WARRANTIES, INCLUDING WITHOUT LIMITATION, WARRANTIES OF MERCHANTABILITY AND FITNESS FOR A PARTICULAR PURPOSE AND WARRANTIES AGAINST HIDDEN OR LATENT DEFECTS, TO THE FULLEST EXTENT PERMITTED BY LAW.

## 10. Limitation of Damages

IN ADDITION TO THE ABOVE WARRANTY DISCLAIMERS AND EXCLUSIONS, TO THE FULLEST EXTENT PERMITTED BY LAW, IN NO EVENT SHALL HBI, ITS EMPLOYEES, AGENTS, OFFICERS, DIRECTORS OR SUPPLIERS BE RESPONSIBLE OR LIABLE IN CONTRACT, WARRANTY, TORT OR OTHERWISE FOR ANY INDIRECT, INCIDENTAL, SPECIAL, PUNITIVE, EXEMPLARY OR CONSEQUENTIAL DAMAGES, INCLUDING LOST PROFITS, GOODWILL, BUSINESS INTERRUPTION OR ANY OTHER LOSSES (OTHER THAN THE COST OF THE PRODUCT OR ITS REPLACEMENT) THAT ARISE DIRECTLY OR INDIRECTLY OUT OF YOUR PURCHASE OR USE OF THE PRODUCT, EVEN IF WE HAVE BEEN ADVISED OF THE POSSIBILITY OF SUCH DAMAGES. TO THE FULLEST EXTENT PERMITTED BY LAW, HBI'S AGGREGATE CUMULATIVE LIABILITY HEREUNDER SHALL NOT EXCEED THE ORIGINAL PURCHASE PRICE PAID FOR THE PRODUCT THAT CAUSED SUCH DAMAGE. CERTAIN STATES (COUNTRIES AND PROVINCES) DO NOT ALLOW THE EXCLUSION OR LIMITATION OF CERTAIN CATEGORIES OF DAMAGES, SO THE EXCLUSIONS SET FORTH ABOVE MAY NOT APPLY TO YOU AND YOU MAY HAVE ADDITIONAL RIGHTS.

THE LIMITATIONS AND EXCLUSIONS OF LIABILITY IN THIS SECTION ARE NOT APPLICABLE TO RESIDENTS OF NEW JERSEY. WITH RESPECT TO RESIDENTS OF NEW JERSEY, HBI IS NOT LIABLE FOR ANY DAMAGES ARISING FROM OR RELATING TO THE PRODUCTS UNLESS SUCH DAMAGES ARE THE RESULT OF OUR NEGLIGENT, RECKLESS OR INTENTIONAL ACTS OR OMISSIONS; AND TO THE FULLEST EXTENT PERMITTED BY LAW WE ARE NOT LIABLE FOR INCIDENTAL, SPECIAL OR CONSEQUENTIAL DAMAGES.

# COMPLIANCE NOTICE

This device complies with Part 15 of the FCC Rules and Industry Canada license-exempt RSS standard(s). Operation is subject to the following two conditions: (1) this device may not cause harmful interference, and (2) this device must accept any interference received, including interference that may cause undesired operation.

Le présent appareil est conforme aux CNR d'Industrie Canada applicables aux appareils radio exempts de licence. L'exploitation est autorisée aux deux conditions suivantes:

- (1) l'appareil ne doit pas produire de brouillage, et
- (2) l'utilisateur de l'appareil doit accepter tout brouillage radioélectrique subi, même si le brouillage est susceptible d'en compromettre le fonctionnement.

## FCC and IC Radiation Exposure Statement:

This equipment complies with FCC and Canada radiation exposure limits set forth for an uncontrolled environment. This transmitter must not be co-located or operating in conjunction with any other antenna or transmitter.

## Déclaration d'IC sur l'exposition aux radiations:

Cet équipement est conforme aux limites d'exposition aux radiations définies par le Canada pour des environnements non contrôlés. Cet émetteur ne doit pas être installé même endroit ni utilisé avec une autre antenne ou un autre émetteur.

CAUTION: Changes or modifications to this unit not expressly approved by Happiest Baby could void the user's authority to operate this equipment.

This transmitter must not be co-located or operating in conjunction with any other antenna or transmitter.

NOTE: This equipment has been tested and found to comply with the limits for a Class B digital device, pursuant to part 15 of the FCC Rules. These limits are designed to provide reasonable protection against harmful interference in a residential installation. This equipment generates, uses and can radiate radio frequency energy and, if not installed and used in accordance with the instructions, may cause harmful interference to radio communications. However, there is no guarantee that interference will not occur in a particular installation. If this equipment does cause harmful interference to radio or television reception, which can be determined by turning the equipment off and on, the user is encouraged to try to correct the interference by one or more of the following measures:

- Reorient or relocate the receiver
- Increase the separation between the equipment and the receiver
- Connect the equipment into an outlet on a circuit different from that to which the receiver is connected.
- Consult the dealer or an experienced radio/TV technician for help

This Class B digital apparatus complies with Canadian ICES-003.

## TURNING SNOO ON

- Press power button on the front of SNOO. (The power button light will turn from white to purple. And, SNOO will respond by making sound / motion.)
- If crying continues, SNOO will move through 4 levels of increasing sound / motion, to find the one that works best to calm your baby's upset.
- To manually increase the level of sound / motion, simply press and hold power button for a few seconds. The button will change color and SNOO will go up to the next level. (See chart below for a description of the colors indicating each level.)
- To stop all sound / motion, simply push power button one time.

## SNOO ACTIVITY LIGHT INDICATOR

	SNOO is in Sleep Mode
	SNOO is in Level 1
	SNOO is in Level 2
	SNOO is in Level 3
	SNOO is in Level 4
	SNOO Timed Out (still crying)

# CONNECTING SNOO TO THE INTERNET

Using the SNOO app, you can change the level of sound / motion and customize your settings.

1. Download the SNOO app from Apple® App Store or Google Play®.
2. Turn SNOO on by pressing power button.
3. Check your phone to see that you are connected to your home wireless network.
4. Carefully follow steps provided by the SNOO app to connect SNOO to your home wireless network.
5. Now, you're ready to start using SNOO with the app!

# LIMITED WARRANTY

By using the Happiest Baby Snoo Smart Sleeper (the "Product") you agree to be bound by the terms of this Limited Warranty set forth below and provided by Happiest Baby®, Inc. ("HBI", "us", "we", "our"). If you do not agree to the terms of this Limited Warranty you may return the Product (in its original, unused condition) within 30 days of receipt (or the return period provided by your place of purchase, whichever is longer) for a refund in accordance with our returns policy as set forth in Section 3 of this Limited Warranty.

This Limited Warranty gives you specific legal rights. You may also have other or additional legal rights under the laws of your state, province or jurisdiction. The disclaimers, exclusions, and limitations of liability under this Limited Warranty will not apply to the extent prohibited by applicable law. For a full description of your legal rights you should refer to the laws applicable in your jurisdiction.

- 1. Limited Warranty Rights** Apply only to the Original Purchaser. Subject to the additional terms and conditions set forth below, only an original purchaser in the United States of the Product from us or from one of our authorized resellers or distributors has rights under this Limited Warranty.
- 2. Limited Warranty.** HBI warrants the Product against defects in materials and workmanship under normal use for a period of twelve (12) months from the date of purchase ("Warranty Period"). If a Product is returned to us during the Warranty Period as provided below, and we determine that the Product is defective, HBI will at its sole discretion (i) repair the Product, (ii) replace the Product or any defective components or parts with a new or refurbished similar product, component or part. If the Warranty Period has expired or is otherwise not applicable as per the Scope and Limitation on Warranty (below), we will return the Product to you at your expense. More information about this warranty can be found at [www.happiestbaby.com/customer-care](http://www.happiestbaby.com/customer-care)
- 3. Return Policy.** If you are the original purchaser of the Product and you are not satisfied with the Product for any reason, you may return it to us in its original condition within thirty (30) days of receipt and receive a full refund, except for any shipping and handling costs. To return your Product you first need to contact HBI's customer care for a Return Merchandise Authorization (RMA) number. RMA numbers are valid for 14 days after issuance, Product returned after the expiration of the RMA number will be returned to the purchaser, at the purchaser's expense.
- 4. Warranty Service Process.** Please review the online help resources at [www.happiestbaby.com/customer-care](http://www.happiestbaby.com/customer-care) prior to seeking service under this Limited Warranty. To obtain warranty service or to return a product to us, you must first obtain a Return Merchandise Authorization (RMA) number from a customer care representative at HBI. We may attempt to troubleshoot a warranty-related problem prior to issuing a RMA number. We may ask for additional information upon request. Issued RMA numbers are valid for fourteen days from issuance. Once a RMA number is obtained, your product must be shipped freight prepaid at your expense either in its original packaging or packaging affording an equal degree of protection, to the HBI authorized distribution facility identified by our customer care representative. Along with the Product, you must also send proof of purchase and all accessories. Failure to return any of the accessories may result in a delay of refund payment or service and/or result in a reduction of your refund, a credit to HBI or an invoice for the missing accessories.
- 5. Replacement Parts; HBI's Determination of Product Status.** In performing service under this Limited Warranty, we may furnish replacement parts on an exchange basis in which event replaced parts will become the property of HBI. Replacement parts provided by us will be new or refurbished and of comparable quality to the replaced part. Replacement parts may also be a different part that contains compatible features and functions. You agree to reimburse us for the shipping/handling, inspection, testing and repair of returned equipment determined by us not to be defective or which falls under one of the warranty exclusions described below. In all cases, our determination as to whether or not the equipment is defective and covered by warranty will be final. You will pay all shipping and handling charges related to shipping back to you any product that we determine not to be defective and is shipped back to you. Any replacement Product or part thereof will be warranted hereunder for a period of twelve (12) months from the date of purchase. We reserve the right to change the method by which we may provide warranty service to you, and the eligibility of your Product to receive a particular method of service.
- 6. Scope of and Limitation of Warranty.** Our warranty obligations related to the Product under this Limited Warranty are limited to the repair or replacement of defective Products or parts thereof as described in the Limited Warranty section above. This warranty does not cover customer training and education, installation, set up or adjustment, signal or reception problems.
- 7. The Product is not a Medical Device.** The Snoo Smart Sleeper is not medical device. HBI makes no warranty or representation that the use of the Product (with or without any third-party product or service) constitutes medical treatment. You understand and acknowledge that HBI's Products or its associated Services will not dispatch emergency authorities in the event of an emergency. Furthermore, HBI's Customer Care contacts cannot be considered a medical resource. If you have an emergency or a medical concern, it is your responsibility to seek medical assistance.
- 8. Exclusions from Limited Warranty.** This Limited Warranty does not cover damage to the Product (i) due to acts of God, other forces beyond our reasonable control, such as internet or power outages, power surges, fires, earthquakes, floods or other events of "force majeure," accident, misuse, abuse, negligence, commercial use or modification of, or to any part of your product; or (ii) caused by any third party product, service or system, use of the Product for purposes other than for which the Product was designed or intended, use in improper temperature, humidity or other environmental conditions, or use of the Product in violation of written instructions provided by HBI (which may be provided at the time of purchase or on its website at <http://www.happiestbaby.com/customer-care>).

# CARE INFORMATION

## SNOO Smart Sleeper: Care and Maintenance Instructions

- Remove the sheet from the mattress and wash it and all 3 SNOO sacks before use.
- The sheet and sleep sacks are machine washable. Wash in warm water with other like colors. Only use non-chlorine bleach. Tumble dry on low heat.
- The SNOO bed, sleep area and mattress should be cleaned regularly with a mild cleaning solution and a soft, damp cloth. Never use bleach.
- Clean mattress with plain water to remove residue (do not use harsh or abrasive cleaners and do not machine wash). Allow to dry completely before using it again.
- When not in use: Store in a clean, dry location. Do not store outdoors or in a damp environment.
- Open the vertical zipper to clean between the inner and outer mesh. Always close zipper completely before resuming use.



# SPECIFICATIONS

<b>Power</b>	12V wall plug power adapter
<b>Wireless</b>	802.11b/g/n @ 2.4GHz
<b>System Requirements</b>	Wireless connection with internet access iPhone or Android with the latest official OS SNOO App Free SNOO account
<b>Language</b>	English
<b>Countries Supported</b>	United States
<b>Environment</b>	Dimensions: 32" (H) x 20" (W) x 36" (L) with legs Weight: 38 lbs. Operating Temperature: 50° to 95° F (10° to 35° C) Storage Temperature: -13° to 113° F (-25° to 45° C) Operating Humidity: 0% to 90% noncondensing
<b>Certification</b>	FCC IC CPSC (ASTM F2194)

# SAFETY INFORMATION

**FAILURE TO FOLLOW THESE WARNINGS AND INSTRUCTIONS COULD RESULT IN SERIOUS INJURY OR DEATH. READ ALL INSTRUCTIONS BEFORE ASSEMBLY AND USE OF THE PRODUCT. ADULT ASSEMBLY REQUIRED. DO NOT USE THIS DEVICE IF IT IS DAMAGED OR BROKEN.**

## **PREVENT FALL HAZARDS**

---

- To help prevent falls, DO NOT USE this product if the infant can push up on hands and knees or has reached 6 months of age, whichever comes first.
- Maximum weight: 25 lbs. (11.3kg.)

## **PREVENT SUFFOCATION HAZARDS**

---

- When using the SNOO Sack, ALWAYS have the zipper fully zipped and make sure the soft protective zipper hood is in place.
- Use only the mattress pad provided by Happiest Baby. NEVER add a pillow, comforter or another mattress for padding.
- NEVER place additional objects in SNOO Smart Sleeper, such as blankets, toys or other materials.
- ALWAYS ensure the mattress pad is positioned correctly. Do not create any pockets between the mattress pad and mesh sides.
- To reduce the risk of SIDS, pediatricians recommend healthy infants to be placed on their backs to sleep, unless otherwise advised by their physician.
- If a sheet is used with the mattress pad, use only the one provided by Happiest Baby, or an authorized Happiest Baby partner.
- NEVER use plastic bags or other plastic film as a mattress cover.
- Discard all plastic packaging materials immediately after opening.
- SNOO is designed and is approved for use with only one baby at a time.

## **PREVENT STRANGULATION HAZARDS**

---

- When using the SNOO Sack, ALWAYS have the zipper fully zipped and make sure the soft protective zipper hood is in place.
- ALWAYS keep SNOO on a flat, even surface.
- NEVER place anything under the SNOO legs or mattress to elevate the baby's head.
- Strings can cause strangulation. Do not place SNOO protective cloth bag or other items with a string in SNOO.
- Keep the power adapter cord out of reach of infants and children.
- DO NOT suspend strings or unapproved mobiles over SNOO or attach strings to toys.
- DO NOT place SNOO near a window or patio door where cord from blinds or drapes can strangle an infant.

# SAFETY INFORMATION CONT.

## PREVENT INJURY HAZARDS

---

- Never place more than one infant to sleep in SNOO Smart Sleeper.
- Never carry SNOO with an infant in it.
- Young children should not be allowed to play unsupervised in the vicinity of SNOO.
- Always remove baby from SNOO before adjusting height.
- Always ensure that SNOO legs are securely attached and screwed into the base before use.
- SNOO should be placed on a horizontal floor.
- Keep away from open fires and other sources of strong heat, such as electric heaters, gas fires, etc.
- Do not place anything in SNOO to elevate the mattress. The American Academy of Pediatrics warns that elevation can result in an infant sliding into a position that might make breathing difficult.

## CAUTION

---

- SNOO IS NOT A SUBSTITUTE FOR RESPONSIBLE ADULT SUPERVISION.
- IMMEDIATELY CONTACT YOUR PHYSICIAN IF YOUR BABY IS UNUSUALLY FUSSY OR NOT RESPONDING NORMALLY.
- Read and follow instructions before assembly and use.
- If you do not have instructions, DO NOT use this product. Call Happiest Baby Customer Care at 1-855-424-6323 or visit [www.happiestbaby.com/customer-care](http://www.happiestbaby.com/customer-care) for help.
- Before using, inspect SNOO for damaged hardware, loose or missing components or sharp edges.
- NEVER use SNOO if any parts are missing or broken. Contact or write Happiest Baby for replacement parts and instructional literature if needed. (DO NOT substitute parts.)
- Discontinue use of this product if your child is able to push up on hands and knees or at 6 months of age, whichever comes first.
- For indoor use only.
- This product is not a toy. Do not allow children to play with it.
- Do not pour water or liquids onto SNOO.
- Only use the power adapter provided. Use of other power adapters may permanently damage the device.
- Keep this user's guide for future reference.

## CONTACT

For support with your Happiest Baby SNOO Smart Sleeper®  
please visit: [www.happiestbaby.com/customercare](http://www.happiestbaby.com/customercare)  
or contact us at:

Happiest Baby, Inc.

1833 Centinela Ave., Santa Monica, CA 90404 USA

[customercare@happiestbaby.com](mailto:customercare@happiestbaby.com)

1-855-424-6323



Designed in California

Manufactured in China

Happiest Baby, Inc.

1833 Centinela Ave., Santa Monica, CA 90404 USA 2015-16 Happiest Baby, Inc.

All Rights Reserved.

Happiest Baby® and SNOO® names and logo designs are registered or pending trademarks in the United States and other jurisdictions owned by Happiest Baby, Inc. Other trademarks and trade names are those of their respective owners.