

Owner's Manual & Safety Instructions

Save This Manual Keep this manual for the safety warnings and precautions, assembly, operating, inspection, maintenance and cleaning procedures. Write the product's serial number in the back of the manual near the assembly diagram (or month and year of purchase if product has no number). Keep this manual and the receipt in a safe and dry place for future reference.

PITTSBURGH[®] AUTOMOTIVE

ITEM 95979 / 95980

10 & 20 Ton Hydraulic Short Body Rams



REV 131

Visit our website at: <http://www.harborfreight.com>

Email our technical support at: productsupport@harborfreight.com

When unpacking, make sure that the product is intact and undamaged. If any parts are missing or broken, please call 1-888-866-5797 as soon as possible.

Copyright © 2007 by Harbor Freight Tools®. All rights reserved.

No portion of this manual or any artwork contained herein may be reproduced in any shape or form without the express written consent of Harbor Freight Tools. Diagrams within this manual may not be drawn proportionally. Due to continuing improvements, actual product may differ slightly from the product described herein. Tools required for assembly and service may not be included.

⚠ WARNING

**Read this material before using this product.
Failure to do so can result in serious injury.
SAVE THIS MANUAL.**

SAVE THIS MANUAL

Keep this manual for the safety warnings and precautions, assembly, operating, inspection, maintenance and cleaning procedures. Write the product's serial number in the back of the manual near the assembly diagram (or month and year of purchase if product has no number). Keep this manual and the receipt in a safe and dry place for future reference.

IMPORTANT SAFETY INFORMATION

In this manual, on the labeling, and all other information provided with this product:



This is the safety alert symbol. It is used to alert you to potential personal injury hazards. Obey all safety messages that follow this symbol to avoid possible injury or death.

DANGER

DANGER indicates a hazardous situation which, if not avoided, will result in death or serious injury.

WARNING

WARNING indicates a hazardous situation which, if not avoided, could result in death or serious injury.

CAUTION

CAUTION, used with the safety alert symbol, indicates a hazardous situation which, if not avoided, could result in minor or moderate injury.

NOTICE

NOTICE is used to address practices not related to personal injury.

CAUTION

CAUTION, without the safety alert symbol, is used to address practices not related to personal injury.



WARNING Read all safety warnings and instructions. Failure to follow the warnings and instructions may result in electric shock, fire and/or serious injury. Save all warnings and instructions for future reference.

WORK AREA

1. Keep your work area clean and well lit. Cluttered benches and dark areas invite accidents.
2. Keep children and visitors away while operating rams. Distractions can cause you to lose control.

PERSONAL SAFETY

1. Stay alert. Watch what you are doing, and use common sense when operating a ram. Do not use a ram while tired or under the influence of drugs, alcohol, or medication. A moment of inattention while operating rams may result in serious personal injury.
2. Wear ANSI-approved safety goggles during service and use.

RAM USE AND CARE

1. Do not force the ram. Use the correct ram for your application. The correct ram will do the job better and safer at the rate for which it is designed. Do not force the ram and do not use the ram for a purpose for which it is not intended.
2. Store idle rams out of reach of children and other untrained persons. Rams are dangerous in the hands of untrained users.
3. Maintain rams with care. Keep rams clean. Properly maintained rams are less likely to bind, break or malfunction. Do not use a damaged ram. Tag damaged rams "Do not use" until repaired.
4. Check for misalignment or binding of moving parts, breakage of parts, and any other condition that may affect the ram's operation. If damaged, have the ram serviced before using. Many accidents are caused by poorly maintained rams.
5. Use only accessories that are recommended by the manufacturer for your model. Accessories that may be suitable for one ram may become hazardous when used on another ram.
6. Check all hydraulic connections and hoses before applying pressure to the Ram.
7. Do not leave the ram unattended when it is pressurized. Release pressure on the ram before leaving work area.
8. Do not exceed working pressure or lift loads heavier than the maximum capacity of the Ram being used.
9. If lifting, support load properly when finished.
10. Follow hydraulic pump instructions.
11. Do not use for aircraft purposes.

SERVICE

1. Ram service must be performed only by qualified repair personnel. Service or maintenance performed by unqualified personnel could result in a risk of injury.
2. When servicing a ram, use only identical replacement parts. Follow instructions in the "Inspection, Maintenance, And Cleaning" section of this manual. Use of unauthorized parts or failure to follow maintenance instructions may create a risk of electric shock or injury.
3. Maintain labels and nameplates on the ram. These carry important information. If unreadable or missing, contact Harbor Freight Tools for a replacement.
4. Repairs or adjustments to hydraulic systems should only be performed by a qualified technician.

UNPACKING

When unpacking, check to make sure that the item is intact and undamaged. If any parts are missing or broken, please call Harbor Freight Tools at the number shown on the cover of this manual as soon as possible.

ASSEMBLY INSTRUCTIONS

1. Using appropriate, grade 8 hardware (not supplied) bolt Base either to the machinery to be moved or against a fixed surface with the piston facing the machinery.
2. If mounted to a fixed surface, that surface and hardware must be able to withstand the force exerted without failing.

SPECIFICATIONS

Model	95979	95980
Capacity	10 Ton	20 Ton
Ram Diameter	38 mm	50 mm
Working Pressure	9250 PSI	9250 PSI
Ram Travel	7/16"	7/16"
Height Range	1.73" – 2.16"	2.05" – 2.48"
Mounting Hole Diameter	0.2"	0.35"
Dimensions	4 1/2" L x 2 1/4" W	5 11/16" L x 3" W

OPERATION INSTRUCTIONS

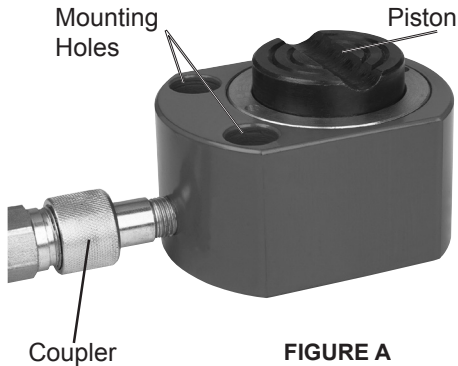

FIGURE A

1. Connect the high pressure hydraulic hose connector to the Coupler.
2. Check the connections between the hydraulic hose, the power source, and Coupler for tightness. These connections must be tight before using the Ram.
3. To operate, apply proper amount of hydraulic pressure to the Ram.
4. When the machinery has moved to the desired location, remove the pressure.
5. After use, wipe with a clean cloth.

INSPECTION, MAINTENANCE, AND CLEANING

1. Before performing any maintenance, be certain that all hydraulic pressure has been removed and any machinery is turned OFF.
2. Before each use, inspect the general condition of the Ram. Check for misalignment or binding of moving parts, cracked or broken parts, and any other condition that may affect its safe operation. If abnormal noise or vibration occurs, have the problem corrected before further use. Check for leaks from the Ram during operation. **Do not use damaged equipment.**

PARTS LIST AND ASSEMBLY DIAGRAM

Part	Description	QTY
1	Nut	1
2	Ram	1
3	Seal Washer	1
4	O-ring	1
5	Cylinder Base	1

Part	Description	QTY
6	Coupling Ring	1
7	Coupling Bolt	1
8	O-ring	1
9	Dust Cap	1

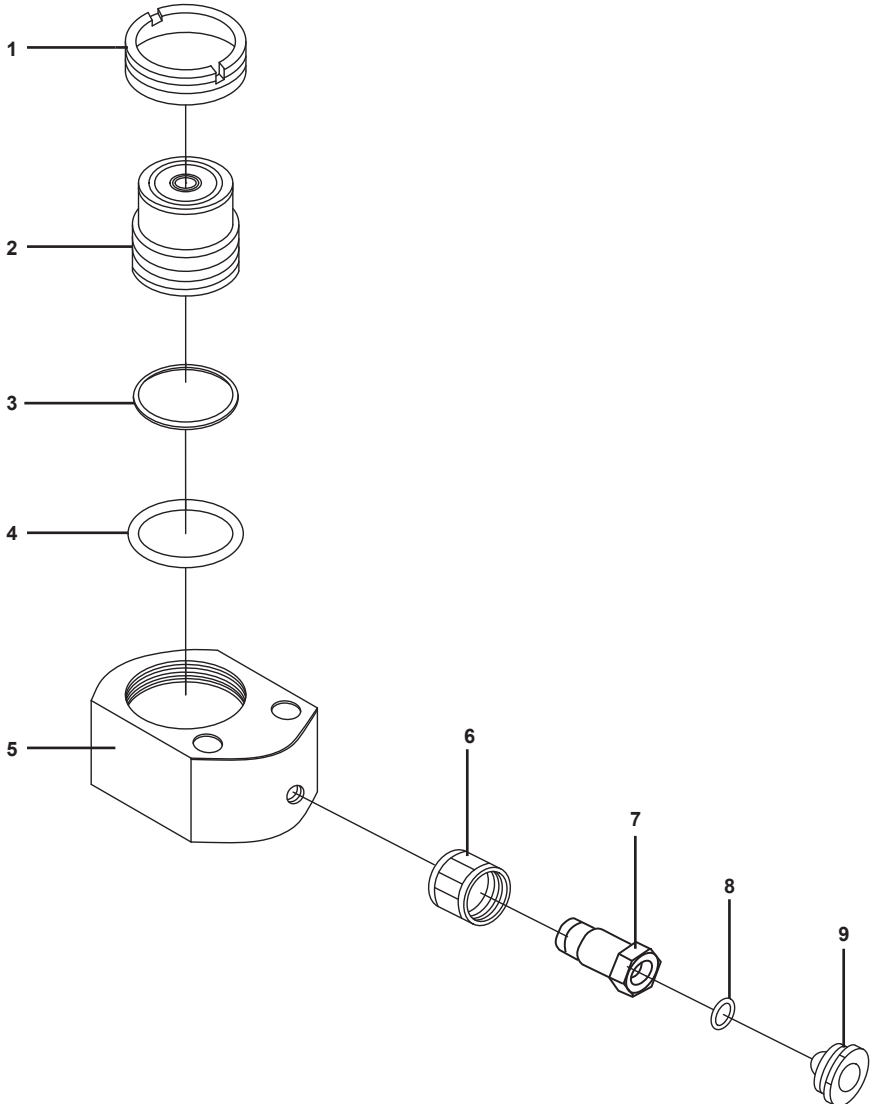

PLEASE READ THE FOLLOWING CAREFULLY

THE MANUFACTURER AND/OR DISTRIBUTOR HAS PROVIDED THE PARTS LIST AND ASSEMBLY DIAGRAM IN THIS MANUAL AS A REFERENCE TOOL ONLY. NEITHER THE MANUFACTURER OR DISTRIBUTOR MAKES ANY REPRESENTATION OR WARRANTY OF ANY KIND TO THE BUYER THAT HE OR SHE IS QUALIFIED TO MAKE ANY REPAIRS TO THE PRODUCT, OR THAT HE OR SHE IS QUALIFIED TO REPLACE ANY PARTS OF THE PRODUCT. IN FACT, THE MANUFACTURER AND/OR DISTRIBUTOR EXPRESSLY STATES THAT ALL REPAIRS AND PARTS REPLACEMENTS SHOULD BE UNDERTAKEN BY CERTIFIED AND LICENSED TECHNICIANS, AND NOT BY THE BUYER. THE BUYER ASSUMES ALL RISK AND LIABILITY ARISING OUT OF HIS OR HER REPAIRS TO THE ORIGINAL PRODUCT OR REPLACEMENT PARTS THERETO, OR ARISING OUT OF HIS OR HER INSTALLATION OF REPLACEMENT PARTS THERETO.

Record Product's Serial Number Here: _____

Note: If product has no serial number, record month and year of purchase instead.

Note: Some parts are listed and shown for illustration purposes only, and are not available individually as replacement parts.

Limited 90 Day Warranty

Harbor Freight Tools Co. makes every effort to assure that its products meet high quality and durability standards, and warrants to the original purchaser that this product is free from defects in materials and workmanship for the period of 90 days from the date of purchase. This warranty does not apply to damage due directly or indirectly, to misuse, abuse, negligence or accidents, repairs or alterations outside our facilities, criminal activity, improper installation, normal wear and tear, or to lack of maintenance. We shall in no event be liable for death, injuries to persons or property, or for incidental, contingent, special or consequential damages arising from the use of our product. Some states do not allow the exclusion or limitation of incidental or consequential damages, so the above limitation of exclusion may not apply to you. THIS WARRANTY IS EXPRESSLY IN LIEU OF ALL OTHER WARRANTIES, EXPRESS OR IMPLIED, INCLUDING THE WARRANTIES OF MERCHANTABILITY AND FITNESS.

To take advantage of this warranty, the product or part must be returned to us with transportation charges prepaid. Proof of purchase date and an explanation of the complaint must accompany the merchandise. If our inspection verifies the defect, we will either repair or replace the product at our election or we may elect to refund the purchase price if we cannot readily and quickly provide you with a replacement. We will return repaired products at our expense, but if we determine there is no defect, or that the defect resulted from causes not within the scope of our warranty, then you must bear the cost of returning the product.

This warranty gives you specific legal rights and you may also have other rights which vary from state to state.

PITTSBURGH[®] AUTOMOTIVE

3491 Mission Oaks Blvd. • PO Box 6009 • Camarillo, CA 93011 • 1-888-866-5797