

Owner's Manual & Safety Instructions

Save This Manual Keep this manual for the safety warnings and precautions, assembly, operating, inspection, maintenance and cleaning procedures. Write the product's serial number in the back of the manual near the assembly diagram (or month and year of purchase if product has no number). Keep this manual and the receipt in a safe and dry place for future reference.

CHICAGO ELECTRIC WELDING

120 VOLT SPOT WELDER

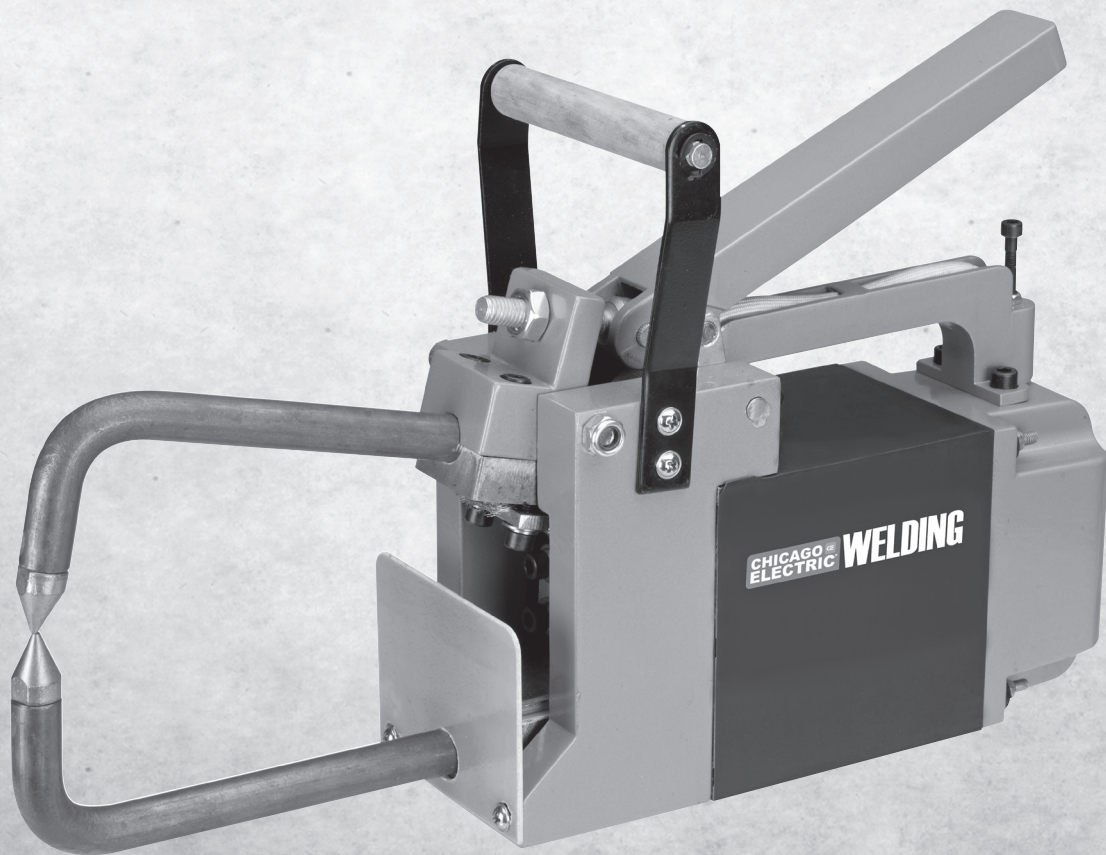

Visit our website at: <http://www.harborfreight.com>
Email our technical support at: tech@harborfreight.com

ITEM 61205

When unpacking, make sure that the product is intact and undamaged. If any parts are missing or broken, please call 1-800-444-3353 as soon as possible.

Copyright© 2013 by Harbor Freight Tools®. All rights reserved. No portion of this manual or any artwork contained herein may be reproduced in any shape or form without the express written consent of Harbor Freight Tools. Diagrams within this manual may not be drawn proportionally. Due to continuing improvements, actual product may differ slightly from the product described herein. Tools required for assembly and service may not be included.

⚠ WARNING

**Read this material before using this product.
Failure to do so can result in serious injury.
SAVE THIS MANUAL.**

Table of Contents

Safety	2	Maintenance	12
Specifications	7	Parts List and Diagrams	14
Setup	8	Warranty	16
Operation.....	10		





SAFETY

SETUP

OPERATION

MAINTENANCE

WARNING SYMBOLS AND DEFINITIONS

	This is the safety alert symbol. It is used to alert you to potential personal injury hazards. Obey all safety messages that follow this symbol to avoid possible injury or death.
	Indicates a hazardous situation which, if not avoided, will result in death or serious injury.
	Indicates a hazardous situation which, if not avoided, could result in death or serious injury.
	Indicates a hazardous situation which, if not avoided, could result in minor or moderate injury.
	Addresses practices not related to personal injury.

IMPORTANT SAFETY INFORMATION

WARNING

Read all safety warnings and instructions.

Failure to follow the warnings and instructions may result in electric shock, fire and/or serious injury.

Save all warnings and instructions for future reference.

General Safety Information

PROTECT yourself and others. Read and understand this information.

- Before use, read and understand manufacturer's instructions, Material Safety Data Sheets (MSDS), employer's safety practices, and ANSI Z49.1.**
- Keep out of reach of children.**
Keep children and bystanders away while operating.
- Hold the Welder securely during use.**
If it falls while plugged in, severe injury, electric shock, or fire may result.
- Stay alert, watch what you are doing and use common sense when operating a welder. Do not use a welder while you are tired or under the influence of drugs, alcohol or medication.**
A moment of inattention while operating welders may result in serious personal injury.
- Do not overreach.**
Keep proper footing and balance at all times.
- Avoid unintentional starting.** Make sure you are prepared to begin work before turning on the Welder.
- Never leave the Welder unattended while energized.** Turn power off if you have to leave.
- The warnings, precautions, and instructions discussed in this instruction manual cannot cover all possible conditions and situations that may occur.** It must be understood by the operator that common sense and caution are factors which cannot be built into this product, but must be supplied by the operator.

9. **This product, when used for welding and similar applications, contains or produces a chemical known to the State of California to cause cancer and birth defects (or other reproductive harm).** (California Health & Safety Code § 25249.5, *et seq.*)
10. **Handling the cord on this product will expose you to lead, a chemical known to the State of California to cause cancer, and birth defects or other reproductive harm.** Wash hands after handling. (California Health & Safety Code § 25249.5, *et seq.*)

Fume and Gas Safety Information



FUMES AND GASES can be hazardous to your health.

1. **Exposure to welding or cutting exhaust fumes can increase the risk of developing certain cancers, such as cancer of the larynx and lung cancer.** Also, some diseases that may be linked to exposure to welding or cutting exhaust fumes are:
 - Early onset of Parkinson's Disease
 - Heart disease
 - Ulcers
 - Damage to the reproductive organs
 - Inflammation of the small intestine or stomach
 - Kidney damage
 - Respiratory diseases such as emphysema, bronchitis, or pneumonia
2. **Do not use near degreasing or painting operations.**
3. **Keep head out of fumes.** Do not breathe exhaust fumes.
4. **Use enough ventilation or exhaust, or both, to keep fumes and gases from breathing zone and general area.** If engineering controls are not feasible, use an approved respirator.
5. **Work in a confined area only if it is well-ventilated, or while wearing an air-supplied respirator.**
6. **Have a recognized specialist in Industrial Hygiene or Environmental Services check the operation and air quality and make recommendations for the specific welding situation.** Follow OSHA guidelines for Permissible Exposure Limits (PEL's) and the American Conference of Governmental Industrial Hygienists recommendations for Threshold Limit Values (TLV's) for fumes and gases.

Arc Ray Safety Information



ARC RAYS can injure eyes and burn skin.

1. **Wear ANSI-approved welding eye protection featuring at least a number 10 shade lens rating.**
2. **Wear leather leggings, fire resistant shoes or boots during use.** Do not wear pants with cuffs, shirts with open pockets, or any clothing that can catch and hold molten metal or sparks.
3. **Keep clothing free of grease, oil, solvents, or any flammable substances.** Wear dry, insulating gloves and protective clothing.
4. **Wear an approved head covering to protect the head and neck.** Use aprons, cape, sleeves, shoulder covers, and bibs designed and approved for welding and cutting procedures.
5. **When welding/cutting overhead or in confined spaces, wear flame resistant ear plugs or ear muffs to keep sparks out of ears.**

Electrical Safety Information



ELECTRIC SHOCK can KILL.

1. **Never leave the Spot Welder unattended while energized.** Turn off and disconnect power when leaving the work area.
2. **Do not touch energized electrical parts.** Wear dry, insulating gloves. Do not touch electrode or conductor tong with bare hand. Do not wear wet or damaged gloves.
3. **Connect to grounded, GFCI-protected power supply only.**
4. **Do not use near water or damp objects.**
5. **People with pacemakers should consult their physician(s) before use.** Electromagnetic fields in close proximity to heart pacemaker could cause pacemaker interference or pacemaker failure.
6. **Do not expose welders to rain or wet conditions.** Water entering a welder will increase the risk of electric shock.
7. **Do not abuse the cord. Never use the cord for carrying, pulling or unplugging the Welder. Keep cord away from heat, oil, sharp edges or moving parts. Damaged or entangled cords increase the risk of electric shock.**
8. **Do not use outdoors.**
9. **Insulate yourself from the workpiece and ground.** Use nonflammable, dry insulating material if possible, or use dry rubber mats, dry wood or plywood, or other dry insulating material large enough to cover your full area of contact with the work or ground.
10. **Use care not to touch the welding tip to grounded material whenever the unit is plugged in.** Electric shock, fire, or burns may happen if appropriate precautions are not taken.

Fire Safety Information



SPARKS AND HOT SLAG can cause fire.

1. **Clear away or protect flammable objects.** Remove or make safe all combustible materials for a radius of 35 feet (10 meters) around the work area. Use a fire resistant material to cover or block all open doorways, windows, cracks, and other openings.
2. **Keep ABC-type fire extinguisher near work area and know how to use it.**
3. **Maintain a safe working environment.** Keep the work area well lit. Make sure there is adequate surrounding workspace. Keep the work area free of obstructions, grease, oil, trash, and other debris.
4. **Do not operate welders in atmospheres containing dangerously reactive or flammable liquids, gases, vapors, or dust.** Provide adequate ventilation in work areas to prevent accumulation of such substances. *Welders create sparks which may ignite flammable substances or make reactive fumes toxic.*
5. **If working on a metal wall, ceiling, etc., prevent ignition of combustibles on the other side by moving the combustibles to a safe location.** If relocation of combustibles is not possible, designate someone to serve as a fire watch, equipped with a fire extinguisher, during the cutting process and for at least one half hour after the cutting is completed.
6. **Do not weld or cut on materials having a combustible coating or combustible internal structure, as in walls or ceilings, without an approved method for eliminating the hazard.**
7. **Do not dispose of hot slag in containers holding combustible materials.**
8. **After welding, make a thorough examination for evidence of fire.** Be aware that easily visible smoke or flame may not be present for some time after the fire has started.
9. **Do not apply heat to a container that has held an unknown substance or a combustible material whose contents, when heated, can produce flammable or explosive vapors.** Clean and purge containers before applying heat. Vent closed containers, including castings, before preheating, welding, or cutting.

Operation Specific Safety Information

1. **Do not use the Welder if the switch does not turn it on and off.** *Any welder that cannot be controlled with the switch is dangerous and must be repaired.*
2. **Disconnect the plug from the power source before making any adjustments, changing accessories, or storing welders.** *Such preventive safety measures reduce the risk of starting the Welder accidentally.*
3. **Prevent unintentional starting. Ensure the switch is in the off-position before connecting to power source or moving the Welder.** *Carrying or energizing welders that have the switch on invites accidents.*
4. **Store idle Welder out of the reach of children and do not allow persons unfamiliar with the Welder or these instructions to operate the Welder.** Welders are dangerous in the hands of untrained users.
5. **Use the Welder and accessories in accordance with these instructions, taking into account the working conditions and the work to be performed.** *Use of the Welder for operations different from those intended could result in a hazardous situation.*

Service Specific Safety Information

1. **Maintain welders. Check for misalignment or binding of moving parts, breakage of parts and any other condition that may affect the Welder's operation. If damaged, have the Welder repaired before use.** *Many accidents are caused by poorly maintained welders.*
2. **Have your Welder serviced by a qualified repair person using only identical replacement parts.** *This will ensure that the safety of the Welder is maintained.*
3. **Maintain labels and nameplates on the Welder.** These carry important information. If unreadable or missing, contact Harbor Freight Tools for a replacement.
4. **Unplug before maintenance.** Unplug the Welder from its electrical outlet before any inspection, maintenance, or cleaning procedures.



SAVE THESE INSTRUCTIONS.

WARNING



TO PREVENT ELECTRIC SHOCK AND DEATH FROM INCORRECT GROUNDING WIRE CONNECTION:

Check with a qualified electrician if you are in doubt as to whether the outlet is properly grounded. Have a plug installed by a certified electrician. Do not use the Welder if the power cord or plug is damaged. If damaged, have it repaired by a service facility before use. If the plug will not fit the outlet, have a proper outlet installed by a qualified electrician.

Grounded Welders



1. The grounding prong in the plug is connected through the green wire inside the cord to the grounding system in the Welder. The green wire in the cord must be the only wire connected to the Welder's grounding system and must never be attached to an electrically "live" terminal.
2. The Welder must be plugged into an appropriate outlet, properly installed and grounded in accordance with all codes and ordinances.

Extension Cords

1. **If an extension cord is used, it must have the following wire size: up to 30 feet, use 10 AWG size wire; 30 to 50 feet, use 8 AWG wire; Over 50 feet, use 6 AWG wire.**
2. As the distance from the supply outlet increases, a heavier gauge extension cord must be used. Using extension cords with inadequately sized wire causes a serious drop in voltage, resulting in loss of power and possible Welder damage.
3. The smaller the gauge number of the wire, the greater the capacity of the cord. For example, a 14 gauge cord can carry a higher current than a 16 gauge cord.
4. When using more than one extension cord to make up the total length, make sure each cord contains at least the minimum wire size required.
5. If using one extension cord for more than one welder, add the nameplate amperes and use the sum to determine the required minimum cord size.
6. If using an extension cord outdoors, make sure it is marked with the suffix "W-A" ("W" in Canada) to indicate it is acceptable for outdoor use.
7. Make sure the extension cord is properly wired and in good electrical condition. Always replace a damaged extension cord or have it repaired by a qualified electrician before using it.
8. Protect the extension cords from sharp objects, excessive heat, and damp or wet areas.

CHICAGO  **ELECTRIC** **WELDING**

Symbology

	Canadian Standards Association	A	Amperes
	Underwriters Laboratories, Inc.	OCV	Open Circuit Voltage
	Housing Ground Point	KVA	Kilovolt Amperes (Volts / 1000 * Amperes)
V	Volts	AWG	American Wire Gauge
~	Alternating Current		

Specifications

Electrical Rating	120V~ / 13.5A
Rated Output	1.5 kVA @ 50% Duty Cycle
Output Amps ± 10%	5500
Weldable Materials	Uncoated mild, galvanized, or stainless sheet steel Not for welding aluminum, copper or copper alloys
Capacity	Mild Steel: up to a combined thickness of 1/8" sheet steel Galvanized Steel: two pieces of 20 gauge (0.039") sheet steel
Duty Cycle	50% @ 1.5 kVA, based on 10 second time period – unit can weld for 5 seconds out of each 10 second time interval

CHICAGO  **ELECTRIC** **WELDING**

Setup



Read the **ENTIRE IMPORTANT SAFETY INFORMATION** section at the beginning of this manual including all text under subheadings therein before set up or use of this product.

Note: For additional information regarding the parts listed in the following pages, refer to Parts List and Diagrams on page 14.

Components

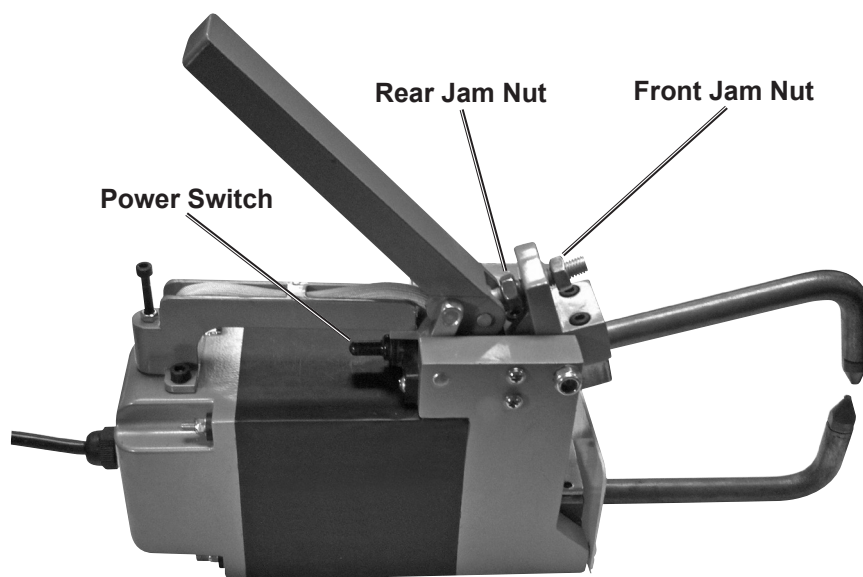
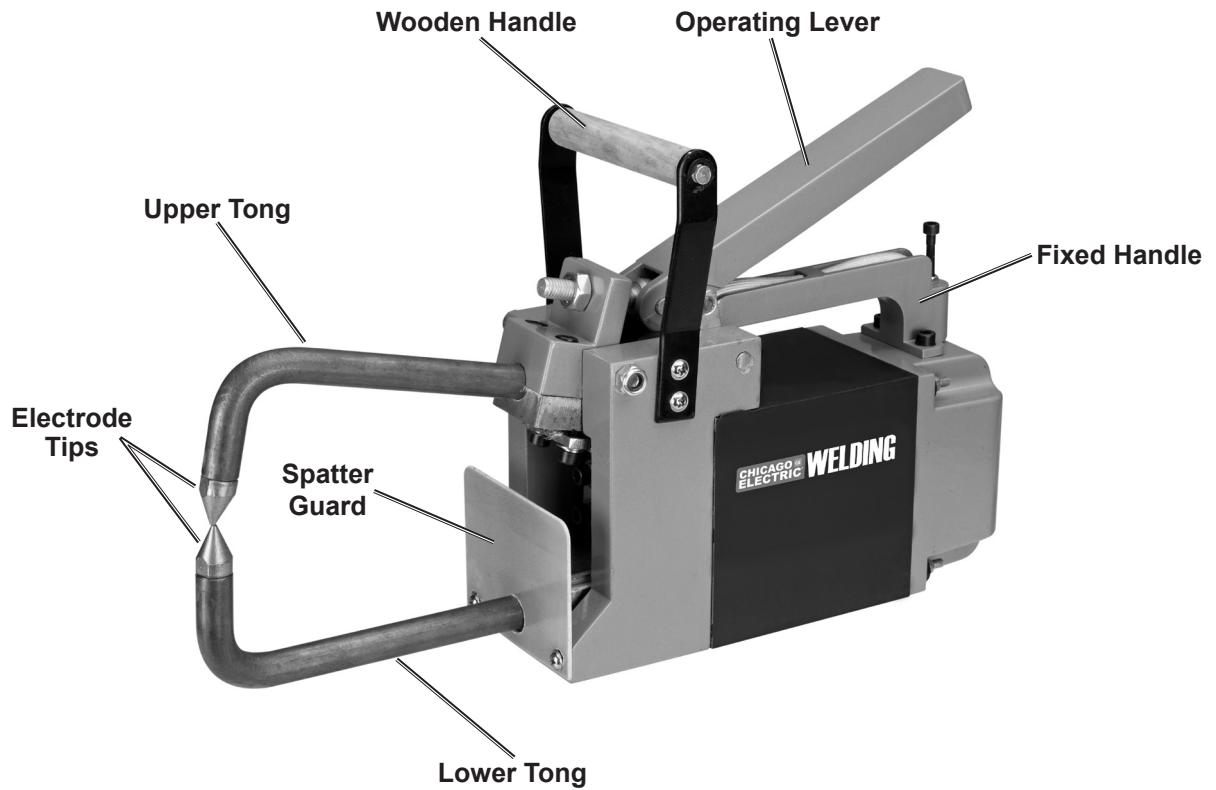

Figure A

Dressing Electrode Tips

1. Electrode Tips (24) deform during use. For optimal weld quality, inspect Electrode Tips before use and clean, dress (resurface), or replace as needed to maintain a proper contact surface.
2. Use a file or tip dresser tool (both not included) to dress Electrode Tips and restore the spot diameter and face angle to a condition approximately the same as a new tip. See Figure B.

Note: When welding thinner materials a smaller tip diameter is required than when welding thicker materials.

3. Used Electrode Tips that cannot be restored to a suitable condition by dressing will need to be replaced. Refer to Replacing Electrode Tips on page 12.

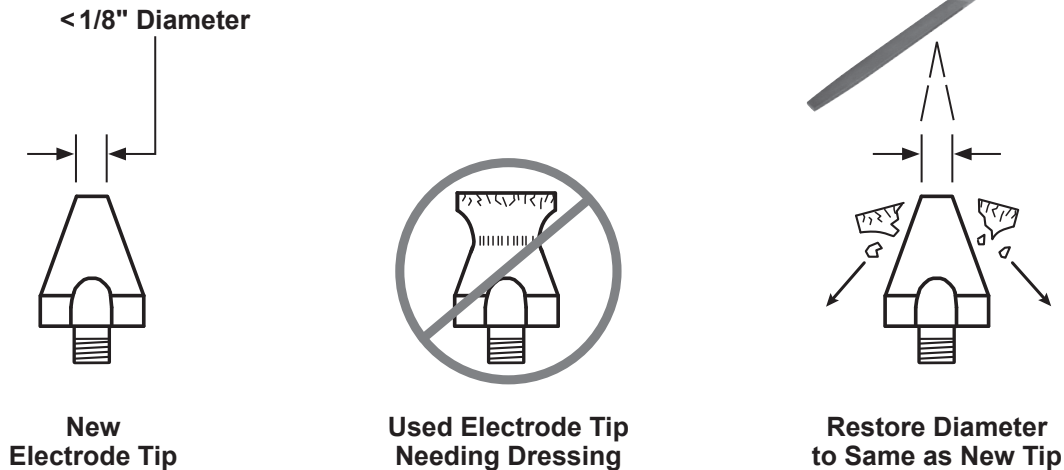

Figure B

Tong and Electrode Tip Alignment

1. Correct Tong/Electrode Tip alignment is necessary to create a proper weld. Check to make sure the Upper Tong (19) is aligned correctly with the Lower Tong (19a) and that the Electrode Tips (24) are centered and touch each other exactly prior to welding operation. See Figure C.
2. To adjust the Upper Tong, loosen the four Cap Screws (15) located at the top/front of the tool. Refer to Assembly Diagram on page 15.
3. To adjust the Lower Tong, loosen the four Cap Screws (30) located at the bottom/front of the tool. Refer to Assembly Diagram on page 15.
4. Align the Upper and Lower Tongs and Electrode Tips as shown in Figure C.
5. When alignment is complete retighten the Cap Screws.

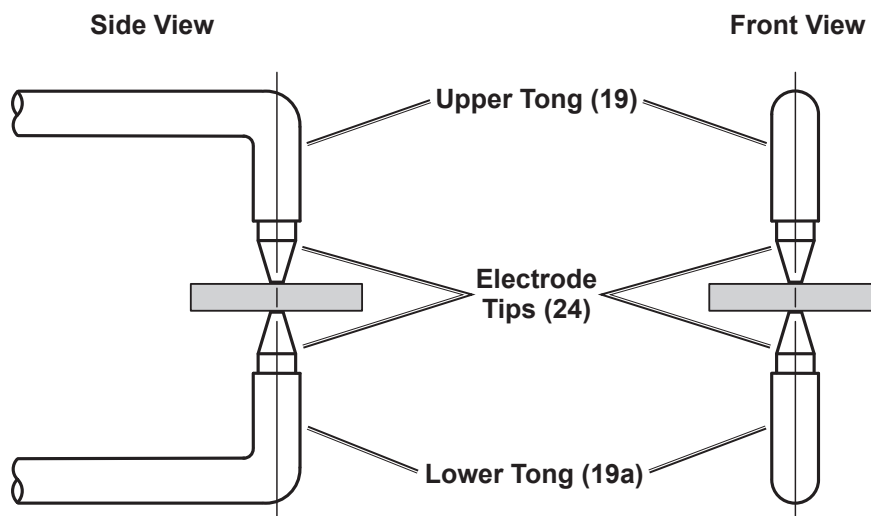

Figure C

Operation



Read the **ENTIRE IMPORTANT SAFETY INFORMATION** section at the beginning of this manual including all text under subheadings therein before set up or use of this product.

Adjusting Tong and Operating Lever Pressure

WARNING! TO PREVENT SERIOUS INJURY AND ELECTRIC SHOCK: Prior to adjusting the Tong and Operating Lever pressure, make sure the Spot Welder is disconnected from its electrical supply source.

NOTICE: Excessive Tong pressure can damage the Electrode Tips. Do not attempt to hold the workpieces together by using the Tongs under high pressure as a clamp or vise. To avoid damage, use separate clamps to hold workpieces together if needed to make good contact at the intended weld point.

1. The amount of pressure applied by the Tongs is adjustable, and should be checked and/or set before operation. Correct Tong pressure is necessary to create a proper weld and to prevent damage to the Electrode Tips.
2. **If the Tong pressure is too weak**, and the workpieces are loose when the Tongs close, severe arcing will occur between the workpieces when current is applied and no weld will be produced. **To increase the Tong pressure**, loosen the front Jam Nut. The more the front Jam Nut is loosened, the greater the pressure on the Electrode Tips when the Operating Lever is pushed down to close the Tongs. When the desired pressure is achieved, turn the rear Jam Nut toward the Upper Tong Holder to lock in position. See Figure D.

3. **If the Tong pressure is too strong**, the weld nugget will dimple, and molten material will be forced out around the weld point. **To decrease the Tong pressure**, loosen the rear Jam Nut and turn the front Jam Nut toward the Upper Tong Holder to lock the desired pressure in position. See Figure D.
4. Adjusting the Cap Screw at the rear of the Fixed Handle will determine how firmly the Tongs apply pressure to the workpiece. The farther down the Cap Screw is turned, the farther down the Operating Lever will close and the more Tong pressure will be applied. Adjust the Cap Screw to allow the Operating Lever to be raised easily after completion of the welding process. See Figure E.
5. The pressure required to push down the Operating Lever may be adjusted by turning the Hex Nuts located on each side of the Front Housing clockwise or counterclockwise to loosen or tighten the Lever action. See Figure D.

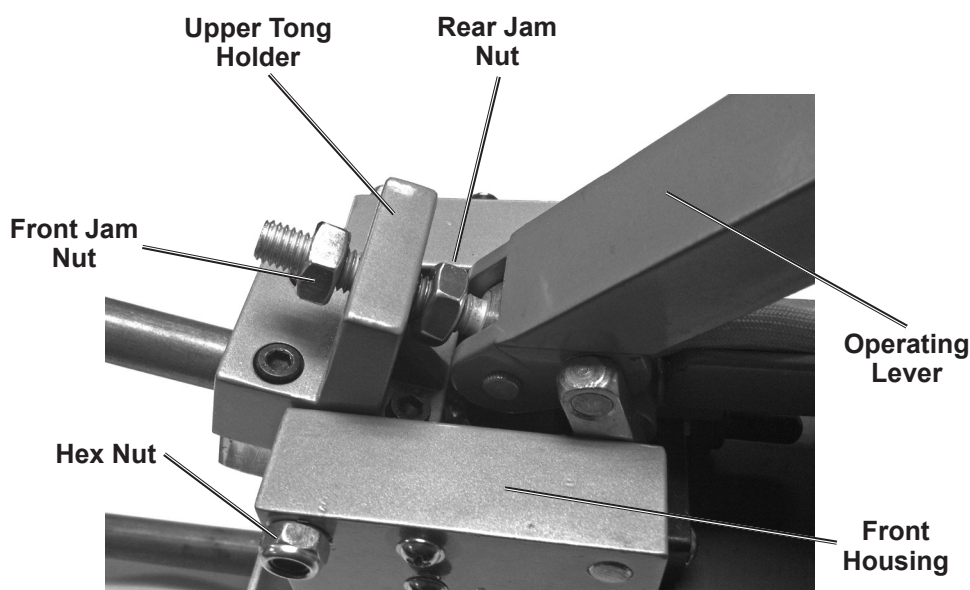

Figure D

General Operating Instructions

WARNING! TO PREVENT SERIOUS INJURY AND ELECTRIC SHOCK: Never touch the Upper and Lower Tongs when welding a workpiece. Allow the Electrode Tips and the workpiece to cool before handling.

1. Ensure that materials to be welded are free from scale, oxides, paint, grease, and oil.
2. The Operating Lever allows opening and closing of the Upper and Lower Tongs.
3. To begin welding process, push down on the Operating Lever to close the Tongs and compress the workpieces between the Electrode Tips. Ensure there are no gaps between the workpieces as this will weaken the weld.

4. Push and hold the Power Switch *sideways* in either direction to apply electric current. Release the Power Switch to shut off current and stop the welding process.

Note: The spot welding time is determined by the thickness of the workpieces, the type of metals, and the skill of the operator.

5. Raise the Operating Lever after each weld is made to open the Tongs and release the workpieces.

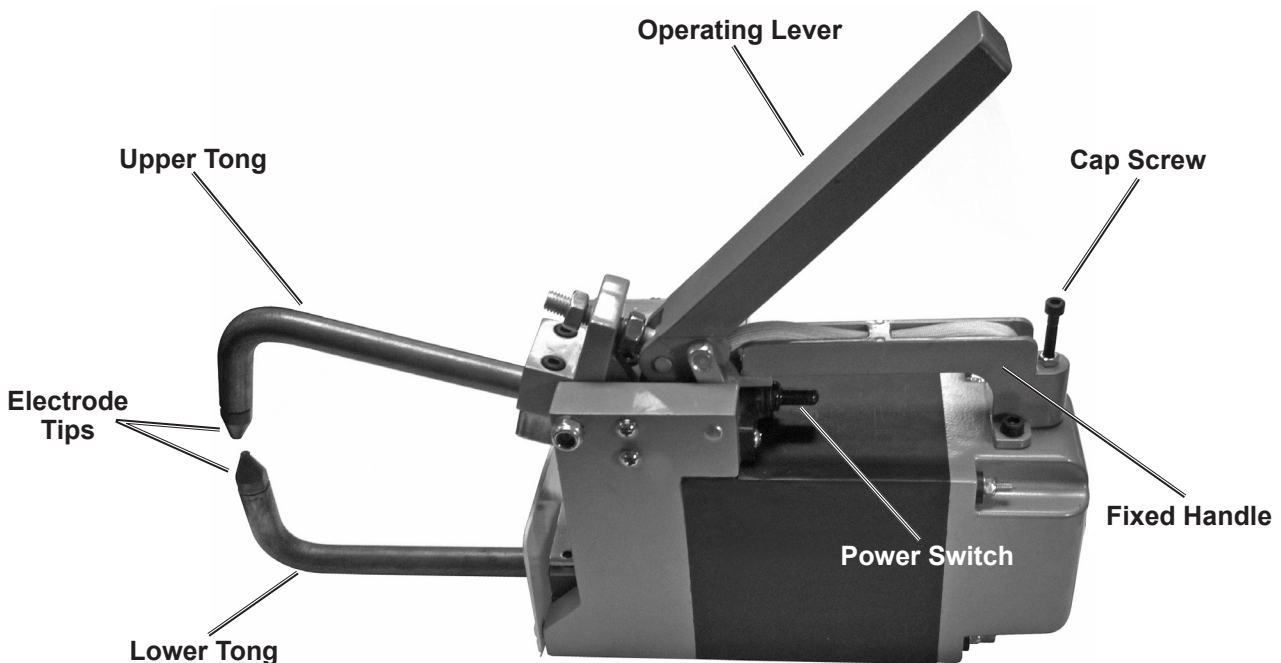
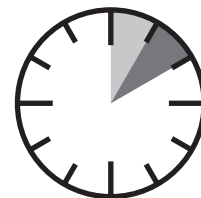

Figure E

Duty Cycle (Duration of Use)

Avoid damage to the Welder by not welding for more than the prescribed duty cycle time. This Welder has a 50% duty cycle at rated output (1.5kVA) based on a 10 second time period, meaning unit can weld for 5 seconds out of each 10 second time interval without overheating. Failure to carefully observe duty cycle limitations can easily over-stress a welder's power generation system contributing to premature welder failure.



**50% Rated Duty Cycle
at 1.5 kVA output
5 seconds welding
followed by
5 seconds of rest**

Maintenance



Procedures not specifically explained in this manual must be performed only by a qualified technician.

⚠️ WARNING



TO PREVENT SERIOUS INJURY, FIRE AND BURNS:
Unplug the Welder and allow all parts of the Welder to cool thoroughly before service.

TO PREVENT SERIOUS INJURY FROM WELDER FAILURE:

Do not use damaged equipment. If abnormal noise or vibration occurs, have the problem corrected before further use.

- BEFORE EACH USE**, inspect the general condition of the Welder. Check for:
 - loose hardware
 - misalignment or binding of moving parts
 - cracked or broken parts
 - damaged electrical wiring
 - any other condition that may affect its safe operation.
- AFTER USE**, wipe external surfaces of the Welder with clean cloth.
- Periodically inspect Electrode Tips and clean, dress (resurface), or replace as needed to maintain a proper contact surface. Refer to Dressing Electrode Tips on page 9 and Replacing Electrode Tips below.
- ⚠️ WARNING!** If the supply cord of this Welder is damaged, it must be replaced only by a qualified service technician.

Replacing Electrode Tips

- Used Electrode Tips that cannot be restored to a suitable condition by dressing will need to be replaced.
- To replace Electrode Tips, remove used Tips from the Upper and Lower Tongs.
- To attach new Electrode Tips to the Upper and Lower Tongs, coat Tip threads with heat sink compound (not included) and screw the Tips onto the Tongs as shown in Figure F. Do not overtighten.

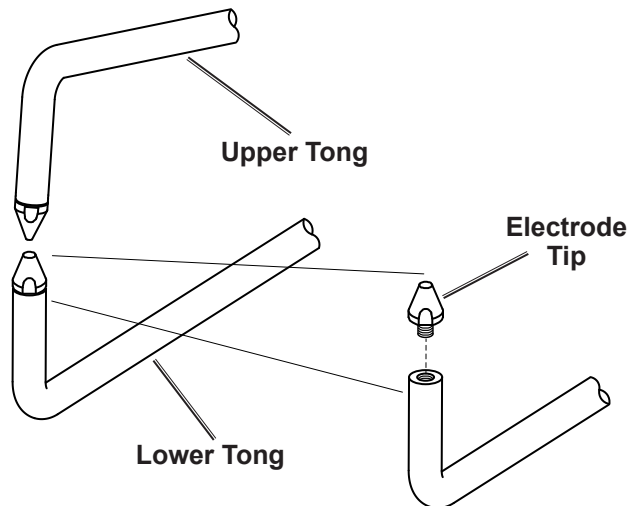

Figure F

Troubleshooting

Problem	Possible Causes	Likely Solutions
No Weld Output	<ol style="list-style-type: none"> 1. Unit not plugged into electrical outlet. 2. Building's fuse or circuit breaker blown. 3. Power Switch damaged or worn. 	<ol style="list-style-type: none"> 1. Plug Power Cord into electrical outlet. 2. Replace building's fuse or reset circuit breaker. 3. Have a qualified technician inspect Power Switch and replace if necessary.
Poor Welding Occurs	<ol style="list-style-type: none"> 1. Electrode Tips deformed, dirty, oxidized, or pitted. 2. Tongs dirty or oxidized. 3. Poor contact with workpieces. 4. Coatings on workpieces inhibiting good contact. 5. Material too thick for Spot Welder. 	<ol style="list-style-type: none"> 1. Dress or replace Electrode Tips. Refer to Dressing Electrode Tips on page 9 or Replacing Electrode Tips on page 12. 2. Clean or replace Tongs. 3. Adjust Tong pressure. Refer to Adjusting Tong and Operating Lever Pressure on page 10. 4. Remove paint, oxides, chemical compounds including galvanized coating. 5. Ensure that workpiece thickness is within capacity of Spot Welder. Refer to Specifications on page 7.
Longer Than Normal Weld Time Required	<ol style="list-style-type: none"> 1. Electrode Tips deformed, dirty, oxidized, or pitted. 2. Metals to be welded are dirty. 3. Tongs dirty or oxidized. 4. Facility line voltage low. 	<ol style="list-style-type: none"> 1. Dress or replace Electrode Tips. Refer to Dressing Electrode Tips on page 9 or Replacing Electrode Tips on page 12. 2. Clean metals with fine wet-dry sandpaper. 3. Clean or replace Tongs. 4. Check input line voltage with voltmeter.
Burn Through at Weld Point	<ol style="list-style-type: none"> 1. Weld time too long. 2. Tongs out of alignment. 3. Electrode Tips deformed, dirty, oxidized, or pitted. 	<ol style="list-style-type: none"> 1. Shorten weld time. 2. Realign Tongs. Refer to Tong and Electrode Tip Alignment on page 9. 3. Dress or replace Electrode Tips. Refer to Dressing Electrode Tips on page 9 or Replacing Electrode Tips on page 12.
Electrode Tips Overheating	<ol style="list-style-type: none"> 1. Not enough Tong pressure. 2. Weld time too long. 3. Material too thick for Spot Welder. 	<ol style="list-style-type: none"> 1. Increase Tong pressure. Refer to Adjusting Tong and Operating Lever Pressure on page 10. 2. Shorten weld time. 3. Ensure that workpiece thickness is within capacity of Spot Welder. Refer to Specifications on page 7.
Electrode Tips Arcing on Workpieces	<ol style="list-style-type: none"> 1. Not enough Tong pressure. 2. Electrode Tips misaligned. 3. Workpiece material has become welded to Tips. 	<ol style="list-style-type: none"> 1. Increase Tong pressure. Refer to Adjusting Tong and Operating Lever Pressure on page 10. 2. Realign Tips or dress Tips to correct diameter. Refer to Tong and Electrode Tip Alignment and/or Dressing Electrode Tips on page 9. 3. Dress or replace Electrode Tips. Refer to Dressing Electrode Tips on page 9 or Replacing Electrode Tips on page 12.
Hole in Weld	Contact area of Electrode Tips too large.	Dress Electrode Tips to restore spot diameter and face angle to approximate that of new tip. Refer to Dressing Electrode Tips on page 9.
Molten Material Forced Out Around the Weld Point	<ol style="list-style-type: none"> 1. Electrode Tips misaligned. 2. Weld time too long. 3. Too much Tong pressure. 	<ol style="list-style-type: none"> 1. Dress Electrode Tips so they align correctly and lie flat on the workpiece. Refer to Dressing Electrode Tips and/or Tong and Electrode Tip Alignment on page 9. 2. Shorten weld time. 3. Decrease Tong pressure. Refer to Adjusting Tong and Operating Lever Pressure on page 10.



Follow all safety precautions whenever diagnosing or servicing the tool. Disconnect power supply before service.

Wiring Schematic

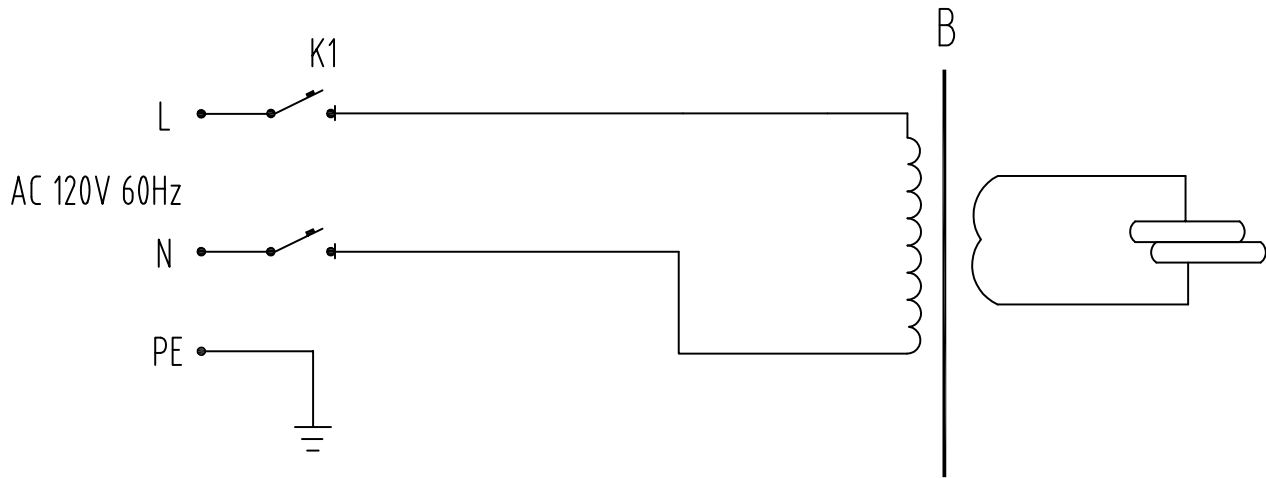

Parts List

Part	Description	Qty	Part	Description	Qty
1	Power Cord	1	20	Lower Tong Insulator	1
2	Insulation Spacer	4	21	Upper Tong Clamp	1
3	Rear Cover	1	22	Lower Tong Clamp Retainer	1
4	Transformer	1	23	Lower Tong Clamp Insulation	1
5	Wire Braid Retainer	1	24	Electrode Tip	2
6	Screw M6 x 35 mm	4	25	Front Housing	1
7	Bolt Ø5 x 165 mm	4	26	Wire Braid	1
8	Screw Ø5 x 10 mm	2	27	Screw Ø5 x 10 mm	2
9	Power Switch	1	28	Splatter Guard	1
10	Cap Screw Ø6 x 45 mm	1	29	Lower Tong Clamp	1
11	Screw Ø6 x 20 mm	2	30	Screw Ø6 x 40 mm	4
12	Operating Lever	1	31	Hex Nut M8	2
13	Connecting Link	2	32	Bolt Ø8 x 97 mm	1
14	Pin Ø8 x 32 mm	1	33	Screw Ø5 x 10 mm	4
15	Screw M6 x 35 mm	8	34	Handle Bracket	2
16	Bolt Ø8 x 97 mm	1	35	Circlip	2
17	Fixed Handle	1	36	Bolt Ø8 x 120 mm	1
18	Upper Tong Holder	1	37	Wooden Handle	1
19	Upper Tong	1	38	Insulating Bushing	4
19a	Lower Tong	1	39	Hex Nut M5	4

Record Product's Serial Number Here: _____

Note: If product has no serial number, record month and year of purchase instead.

Note: Some parts are listed and shown for illustration purposes only, and are not available individually as replacement parts.

Assembly Diagram

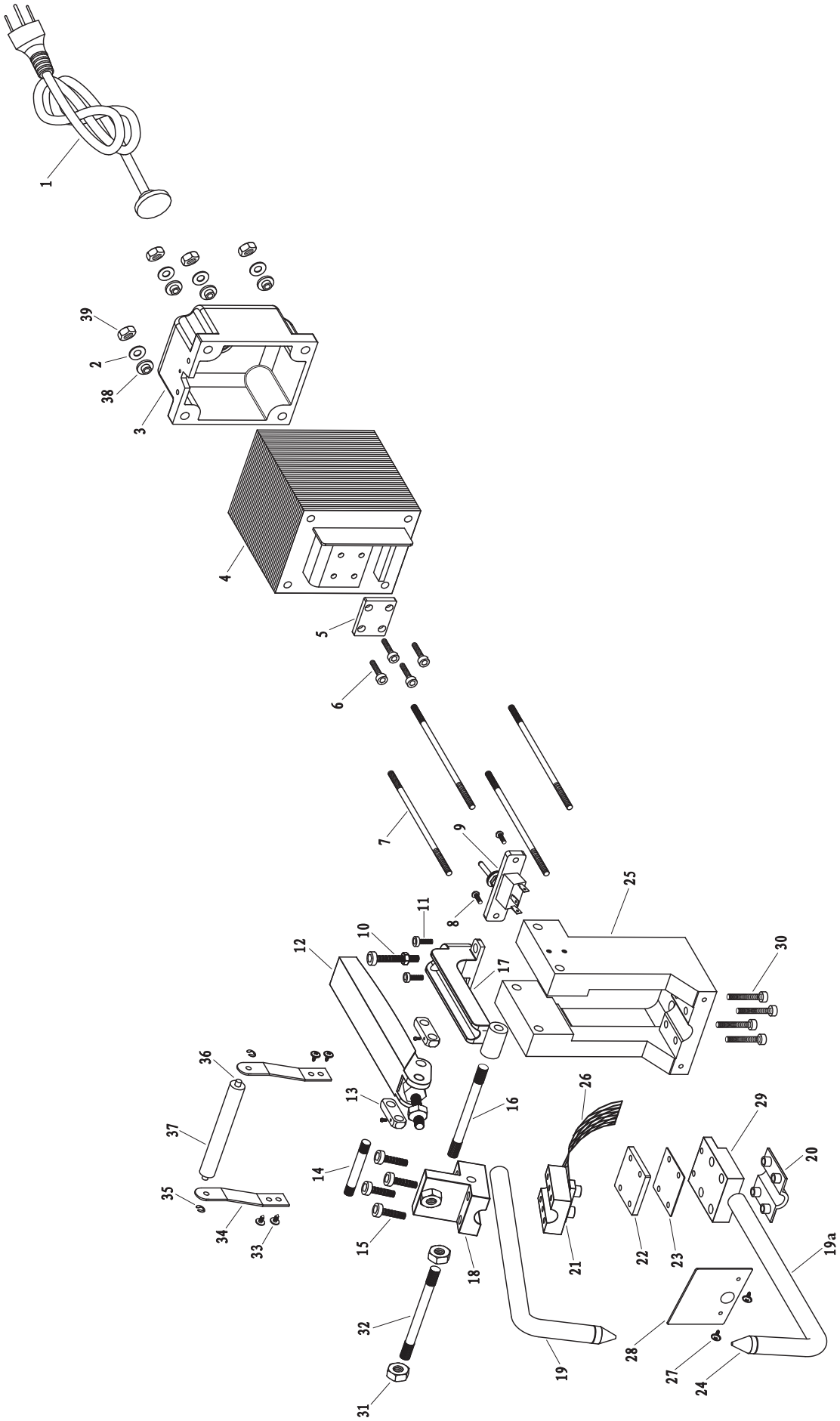

SAFETY

SETUP

OPERATION

MAINTENANCE

PLEASE READ THE FOLLOWING CAREFULLY

THE MANUFACTURER AND/OR DISTRIBUTOR HAS PROVIDED THE PARTS DIAGRAM IN THIS MANUAL AS A REFERENCE TOOL ONLY. NEITHER THE MANUFACTURER NOR DISTRIBUTOR MAKES ANY REPRESENTATION OR WARRANTY OF ANY KIND TO THE BUYER THAT HE OR SHE IS QUALIFIED TO MAKE ANY REPAIRS TO THE PRODUCT OR THAT HE OR SHE IS QUALIFIED TO REPLACE ANY PARTS OF THE PRODUCT. IN FACT, THE MANUFACTURER AND/OR DISTRIBUTOR EXPRESSLY STATES THAT ALL REPAIRS AND PARTS REPLACEMENTS SHOULD BE UNDERTAKEN BY CERTIFIED AND LICENSED TECHNICIANS AND NOT BY THE BUYER. THE BUYER ASSUMES ALL RISK AND LIABILITY ARISING OUT OF HIS OR HER REPAIRS TO THE ORIGINAL PRODUCT OR REPLACEMENT PARTS THERETO, OR ARISING OUT OF HIS OR HER INSTALLATION OF REPLACEMENT PARTS THERETO.

Limited 90 Day Warranty

Harbor Freight Tools Co. makes every effort to assure that its products meet high quality and durability standards, and warrants to the original purchaser that this product is free from defects in materials and workmanship for the period of 90 days from the date of purchase. This warranty does not apply to damage due directly or indirectly, to misuse, abuse, negligence or accidents, repairs or alterations outside our facilities, criminal activity, improper installation, normal wear and tear, or to lack of maintenance. We shall in no event be liable for death, injuries to persons or property, or for incidental, contingent, special or consequential damages arising from the use of our product. Some states do not allow the exclusion or limitation of incidental or consequential damages, so the above limitation of exclusion may not apply to you. THIS WARRANTY IS EXPRESSLY IN LIEU OF ALL OTHER WARRANTIES, EXPRESS OR IMPLIED, INCLUDING THE WARRANTIES OF MERCHANTABILITY AND FITNESS.

To take advantage of this warranty, the product or part must be returned to us with transportation charges prepaid. Proof of purchase date and an explanation of the complaint must accompany the merchandise. If our inspection verifies the defect, we will either repair or replace the product at our election or we may elect to refund the purchase price if we cannot readily and quickly provide you with a replacement. We will return repaired products at our expense, but if we determine there is no defect, or that the defect resulted from causes not within the scope of our warranty, then you must bear the cost of returning the product.

This warranty gives you specific legal rights and you may also have other rights which vary from state to state.

