

Owner's Manual & Safety Instructions

Save This Manual Keep this manual for the safety warnings and precautions, assembly, operating, inspection, maintenance and cleaning procedures. Write the product's serial number in the back of the manual near the assembly diagram (or month and year of purchase if product has no number). Keep this manual and the receipt in a safe and dry place for future reference.

PITTSBURGH[®] AUTOMOTIVE

ITEM 61788

12 Volt, 100 PSI, High Volume Air Compressor



Visit our website at: <http://www.harborfreight.com>
Email our technical support at: productsupport@harborfreight.com

When unpacking, make sure that the product is intact and undamaged. If any parts are missing or broken, please call 1-888-866-5797 as soon as possible.

Copyright© 2013 by Harbor Freight Tools®. All rights reserved.

No portion of this manual or any artwork contained herein may be reproduced in any shape or form without the express written consent of Harbor Freight Tools. Diagrams within this manual may not be drawn proportionally. Due to continuing improvements, actual product may differ slightly from the product described herein. Tools required for assembly and service may not be included.

⚠ WARNING

**Read this material before using this product.
Failure to do so can result in serious injury.
SAVE THIS MANUAL.**

Table of Contents

Safety	2	Maintenance	7
Specifications	5	Parts List and Diagram	10
Operation	6	Warranty	12



WARNING SYMBOLS AND DEFINITIONS

	This is the safety alert symbol. It is used to alert you to potential personal injury hazards. Obey all safety messages that follow this symbol to avoid possible injury or death.
! DANGER	Indicates a hazardous situation which, if not avoided, will result in death or serious injury.
! WARNING	Indicates a hazardous situation which, if not avoided, could result in death or serious injury.
! CAUTION	Indicates a hazardous situation which, if not avoided, could result in minor or moderate injury.
NOTICE CAUTION	Addresses practices not related to personal injury.

SAFETY

SETUP

OPERATION

MAINTENANCE

IMPORTANT SAFETY INFORMATION

General Safety Warnings



WARNING Read all safety warnings and instructions.

Failure to follow the warnings and instructions may result in electric shock, fire and/or serious injury.
Save all warnings and instructions for future reference.

The warnings, precautions, and instructions discussed in this instruction manual cannot cover all possible conditions and situations that may occur. It must be understood by the operator that common sense and caution are factors which cannot be built into this product, but must be supplied by the operator.

1. Work area safety

- a. **Keep work area clean and well lit.**
Cluttered or dark areas invite accidents.
- b. **Do not operate the Compressor in explosive atmospheres, such as in the presence of flammable liquids, gases or dust.**
Compressor motors produce sparks which may ignite the dust or fumes.
- c. **Keep children and bystanders away from an operating compressor.**

2. Electrical safety

- a. **Compressor plugs must match the outlet. Never modify the plug in any way. Do not use any adapter plugs with grounded compressors.** Standard plugs and matching outlets will reduce risk of electric shock.
- b. **Do not expose compressor to rain or wet conditions.** Water entering a compressor will increase the risk of electric shock.
- c. **Do not abuse the cord. Never use the cord for unplugging the compressor. Keep cord away from heat, oil, sharp edges or moving parts.** Damaged or entangled cords increase the risk of electric shock.

3. Personal safety

- a. **Stay alert, watch what you are doing and use common sense when operating this compressor. Do not use this compressor while you are tired or under the influence of drugs, alcohol or medication.** A moment of inattention while operating a compressor may result in serious personal injury.
- b. **Use personal protective equipment. Always wear ANSI-approved eye protection during setup and use.**
- c. **Prevent unintentional starting. Ensure the switch is in the off-position before connecting to power source or moving the compressor.**

4. Compressor use and care

- a. **Do not use the compressor if the switch does not turn it on and off.** Any compressor that cannot be controlled with the switch is dangerous and must be repaired.
- b. **Disconnect the plug from the power source before making any adjustments, changing accessories, or storing the compressor.** Such preventive safety measures reduce the risk of starting the compressor accidentally.
- c. **Store an idle compressor out of the reach of children and do not allow persons unfamiliar with the compressor or these instructions to operate it.** A compressor is dangerous in the hands of untrained users.
- d. **Maintain the compressor. Keep the compressor clean for better and safer performance. Follow instructions for lubricating and changing accessories. Keep dry, clean and free from oil and grease. Check for misalignment or binding of moving parts, breakage of parts and any other condition that may affect the compressor's operation. If damaged, have the compressor repaired before use.** Many accidents are caused by a poorly maintained compressor.
- e. **Use the compressor in accordance with these instructions, taking into account the working conditions and the work to be performed.** Use of the compressor for operations different from those intended could result in a hazardous situation.

5. Service

- a. **Have your compressor serviced by a qualified repair person using only identical replacement parts.** This will ensure that the safety of the compressor is maintained.

Air Compressor Safety Warnings

SAFETY

SETUP

OPERATION

MAINTENANCE

1. **Risk of fire or explosion - do not spray flammable liquid in a confined area or towards a hot surface. Spray area must be well-ventilated. Do not smoke while spraying or spray where spark or flame is present. Arcing parts - keep compressor at least 20 feet away from explosive vapors, such as when spraying with a spray gun.**
2. **Risk of bursting - do not adjust regulator higher than marked maximum pressure of attachment.**
3. **Risk of injury - do not direct air stream at people or animals.**
4. **Do not use to supply breathing air.**
5. **Do not leave compressor unattended for an extended period while plugged in. Unplug compressor after working.**
6. Start and run the vehicle engine during inflation period.
7. **Do not leave compressor plugged in while starting vehicle or while vehicle's engine is off.** Low voltage during these circumstances will increase heat in the wiring and may blow the fusible link in the receptacle or another fuse.
8. Check vehicle manual to ensure the cigarette lighter receptacle is rated at 15 amps or greater. Do not use a socket extension or pigtail to operate this Compressor.
9. Keep compressor well-ventilated. Do not cover compressor during use.
10. Do not remove the valve cover or adjust internal components.
11. Compressor head gets hot during operation. Do not touch it or allow children nearby during or immediately following operation.
12. Do not use the air hose to move the compressor.
13. The use of accessories or attachments not recommended by the manufacturer may result in a risk of injury to persons.
14. All air line components, including hoses, pipe, connectors, filters, etc., must be rated for a minimum working pressure of 150 PSI, or 150% of the maximum system pressure, whichever is greater.
15. Maintain labels and nameplates on the compressor. These carry important safety information. If unreadable or missing, contact Harbor Freight Tools for a replacement.
16. This product is not a toy. Keep it out of reach of children.
17. Operate unit on level surface.
18. People with pacemakers should consult their physician(s) before use. Electromagnetic fields in close proximity to heart pacemaker could cause pacemaker interference or pacemaker failure.
19. **WARNING:** The brass components of this product contain lead, a chemical known to the State of California to cause birth defects (or other reproductive harm). (California Health & Safety code § 25249.5, et seq.)
20. **This Compressor will automatically shut off on overload or under excessive heat.** Should this occur, turn the Power Switch to its "OFF" position. Wait until the Compressor cools. Then, turn the Power Switch to its "ON" position to resume work.



SAVE THESE INSTRUCTIONS.

Specifications

Electrical Rating	12VDC
Maximum Air Pressure	100 PSI
Air Flow Capacity	0.88 CFM
Dimensions	6-5/8" L x 2-7/8" W x 5-1/4" H
Fuse	F15A250V

Components and Controls

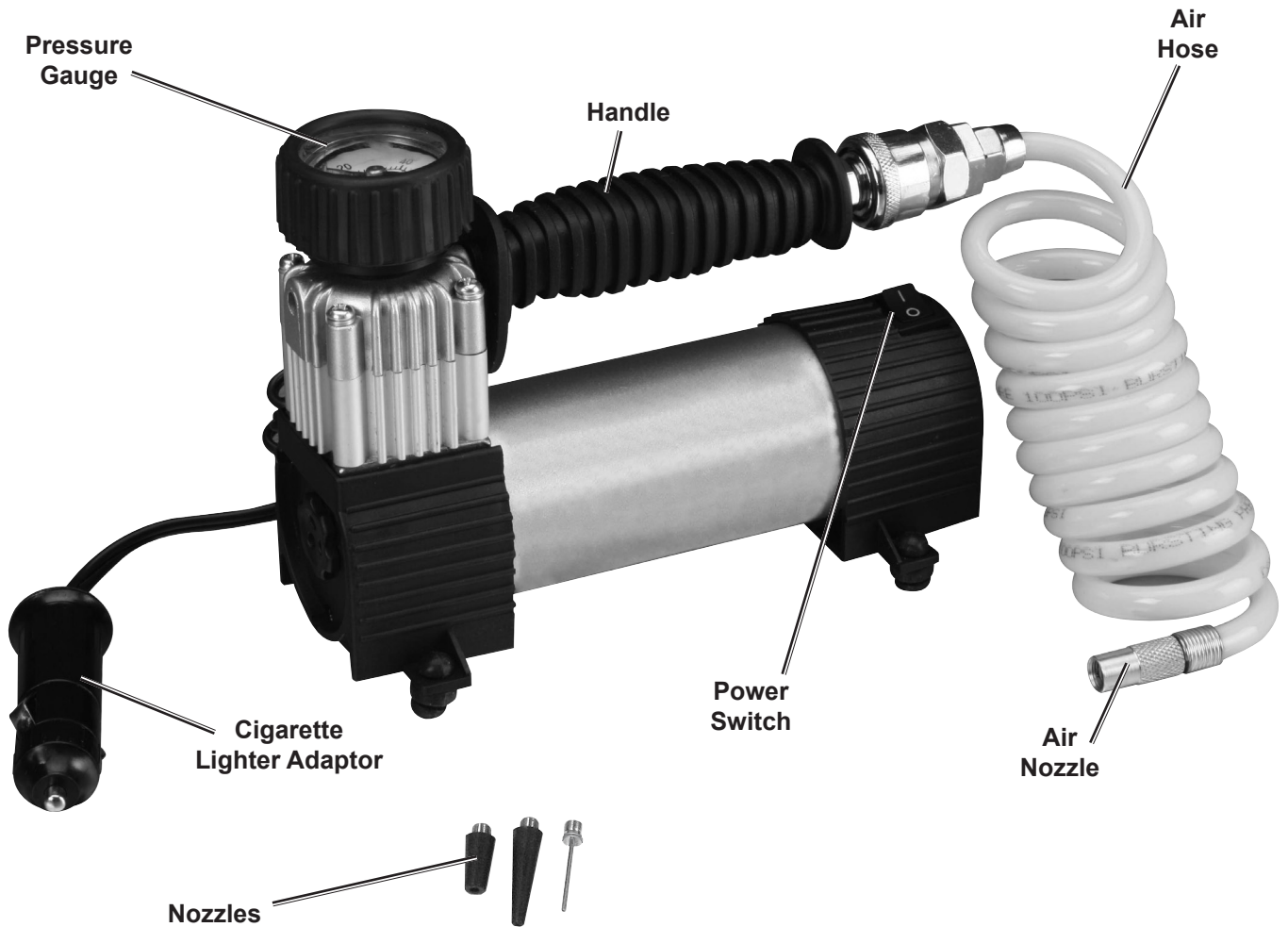

SAFETY

SETUP

OPERATION

MAINTENANCE

Operating Instructions



Read the **ENTIRE IMPORTANT SAFETY INFORMATION** section at the beginning of this manual including all text under subheadings therein before set up or use of this product.

SAFETY

1. Turn the Power Switch to the "OFF" position.
2. Connect the Air Hose to the Compressor.
3. Select the desired Nozzle accessory and attach it to the end of the Air Nozzle.
4. Turn on the car engine.
 - a. Plug the Cigarette Lighter Adapter into the vehicle's cigarette lighter socket.
5. Turn the Compressor On/Off Switch to the "ON" position.

Note: Turn the Compressor on *before* connecting to the tire valve to prevent blowing the fuse.

6. Be sure the valve stem is clean and free of dirt. Holding the Air Nozzle Grip, connect the Nozzle to the valve stem of the item to be inflated.
7. Monitor the Pressure Gauge carefully to avoid over-inflating the item.
8. Continue inflating until the recommended pressure is reached.

SETUP

9. Turn the compressor On/Off Switch to the "OFF" position.
10. Remove the Nozzle from the object.
11. Verify tire pressure with a tire pressure gauge (not included), then replace the valve cap where applicable.
12. If the pressure is low, repeat the steps beginning with Step 5.

CAUTION! Do not inflate the item beyond the manufacturer's inflation rating.

13. When finished, turn off the car engine and unplug the Cigarette Lighter Adapter.

CAUTION! The metal parts of the compressor and hoses will become hot during use. Do not touch them.

14. Allow the Air Compressor to cool, then wipe external surfaces with a clean cloth.
15. Store in a clean, dry, safe location out of the reach of children.

OPERATION

MAINTENANCE

PITTSBURGH[®] AUTOMOTIVE



Procedures not specifically explained in this manual must be performed only by a qualified technician.

WARNING

TO PREVENT INJURY FROM ACCIDENTAL OPERATION:

Turn the Power Switch “OFF” and disconnect from power source before performing any inspection, maintenance, or cleaning procedures.

TO PREVENT SERIOUS INJURY FROM COMPRESSOR FAILURE:

Do not use damaged equipment. If abnormal noise or vibration occurs, have the problem corrected before further use.

Cleaning, Maintenance, and Lubrication

- BEFORE EACH USE**, inspect the general condition of the air compressor. Check for:
 - loose hardware,
 - misalignment or binding of parts,
 - cracked or broken parts,
 - damaged electrical wiring, and
 - any other condition that may affect its safe operation.
- AFTER USE**, allow the unit to cool, then wipe external surfaces of the compressor with a clean cloth.
- Store the Air Compressor in a clean, dry, safe location out of reach of children and other unauthorized people.
- AFTER EVERY 500 HOURS OF REGULAR USE**, replace O-Rings. **Please note:** This work should only be done by a qualified service technician.
- AFTER EVERY 20 USES**, lubricate the Shaft and Snap Rings. **Please note:** This work should only be done by a qualified service technician.
- Replace the Fuse (1C) when required.
 - Unthread and remove the Bezel (1E), the Contact Pin (1D), and the Ring (1B). (See Figure A.) Be careful to not lose any pieces.
 - Slide the Fuse out of the Cigarette Lighter Adaptor.
 - Rest the Ring on the lip of the Cigarette Lighter Adaptor.
 - Insert a new Fuse through the Ring into the Cigarette Lighter Adaptor and use it to press down the internal Spring (1A).
 - Recombine the Bezel with the Contact Pin (the broad end of the Contact Pin should press against the Fuse, as in Figure A), and thread them into the Cigarette Lighter Adaptor.

WARNING! To prevent fire, replace fuse only with fuse of same type and rating. Do not replace with any other object.

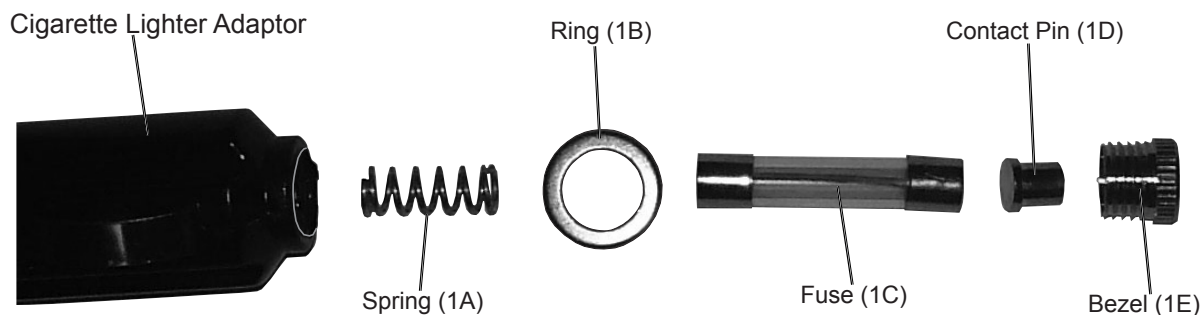

Figure A

Troubleshooting

SAFETY

SETUP

OPERATION

MAINTENANCE

Problem	Possible Causes	Likely Solutions
Decreased output	<ol style="list-style-type: none"> 1. Not enough air pressure and/or air flow. 2. Air leaking from loose housing or connections. 3. Mechanism contaminated. 	<ol style="list-style-type: none"> 1. Check for loose connections. 2. Make sure housing and connections are properly assembled and tight. 3. Have qualified technician clean and where possible, lubricate mechanism.
Severe air leakage (Slight air leakage is normal, especially on older tools)	<ol style="list-style-type: none"> 1. Cross-threaded housing components. 2. Loose housing. 3. Dirty, worn or damaged valve. 	<ol style="list-style-type: none"> 1. Check for incorrect alignment and uneven gaps. If cross-threaded, disassemble and replace damaged parts before use. 2. Tighten housing assembly. If housing cannot be tightened properly, internal parts may be misaligned. 3. Clean or replace valve assembly.
No output	<ol style="list-style-type: none"> 1. Poor connection. 2. Power Switch in Off (O) position. 3. Run-down battery. 4. Blown Fuse. 	<ol style="list-style-type: none"> 1. Check that Cigarette Lighter Adapter is completely inserted into the Cigarette Lighter Socket. 2. Turn Power Switch to On (I) position. 3. Recharge battery. 4. Replace Fuse.
 <p>Follow all safety precautions whenever diagnosing or servicing the tool.</p>		

PLEASE READ THE FOLLOWING CAREFULLY

THE MANUFACTURER AND/OR DISTRIBUTOR HAS PROVIDED THE PARTS LIST AND ASSEMBLY DIAGRAM IN THIS MANUAL AS A REFERENCE TOOL ONLY. NEITHER THE MANUFACTURER OR DISTRIBUTOR MAKES ANY REPRESENTATION OR WARRANTY OF ANY KIND TO THE BUYER THAT HE OR SHE IS QUALIFIED TO MAKE ANY REPAIRS TO THE PRODUCT, OR THAT HE OR SHE IS QUALIFIED TO REPLACE ANY PARTS OF THE PRODUCT. IN FACT, THE MANUFACTURER AND/OR DISTRIBUTOR EXPRESSLY STATES THAT ALL REPAIRS AND PARTS REPLACEMENTS SHOULD BE UNDERTAKEN BY CERTIFIED AND LICENSED TECHNICIANS, AND NOT BY THE BUYER. THE BUYER ASSUMES ALL RISK AND LIABILITY ARISING OUT OF HIS OR HER REPAIRS TO THE ORIGINAL PRODUCT OR REPLACEMENT PARTS THERETO, OR ARISING OUT OF HIS OR HER INSTALLATION OF REPLACEMENT PARTS THERETO.

SAFETY

SETUP

OPERATION

MAINTENANCE

PITTSBURGH[®] AUTOMOTIVE

Parts List

SAFETY

SETUP

OPERATION

MAINTENANCE

Part	Description	Qty
1	Cigarette Lighter Adaptor	1
1A	Spring*	1
1B	Ring*	1
1C	Glass Fuse (F15A250V)*	1
1D	Contact Pin*	1
1E	Bezel*	1
2	Power Cord	1
3	Screw (3x25)	2
4	Power Switch	1
5	Rear Cover	1
6	Shockproof Pad	1
7	Connection Cap	1
8	Screw (4x102)	2
9	Spring Washer (4mm)	2
10	Washer (4mm)	2
11	Power Cord Sleeve	1
12	Overload Protector	1
13	Connection Wire	1
14	Motor Rear Cover	1
15	Brush Holder	1
16	Motor Housing	1
17	Bearing (608z)	1
18	Spring Washer	1
19	Rotor	1
20	Spring Washer	1
21	Bearing (608z)	1
22	End Cover	1
23	Inner Hex Screw (4x8)	1
24	Shockproof Pad	2
25	Air Intake Cover	1
26	Filter Mesh	1
27	Screw (3x10)	3

Part	Description	Qty
28	Front Cover	1
29	Offset Shaft	1
30	Offset Wheel	1
31	Bearing (607z)	1
32	Crank	1
33	Piston Ring	1
34	Press Ring	1
35	Air Intake Slice	2
36	Rivet	2
37	Cylinder Liner	1
38	Radiator Sleeve	1
39	Seal Ring	1
40	Cover	1
41	Seal Ring	1
42	Air Exhaust Slice	1
43	Rivet	1
44	Seal Ring	1
45	Cylinder Cover	1
46	Spring Washer (4mm)	4
47	Screw (4x35)	4
48	Support Ring	1
49	Pressure Meter	1
50	Protective Sleeve	1
51	Air Outlet Tube (8x114)	1
52	Handle	1
53	Air Outlet	1
54	Quick Connector	1
55	Air Hose (Ø8x5')	1
56	Lock Spring	1
57	Air Nozzle	1
58	Needle Nozzle*	1
59	Inflator Nozzle*	2

*Part not shown in Diagram.

Assembly Diagram

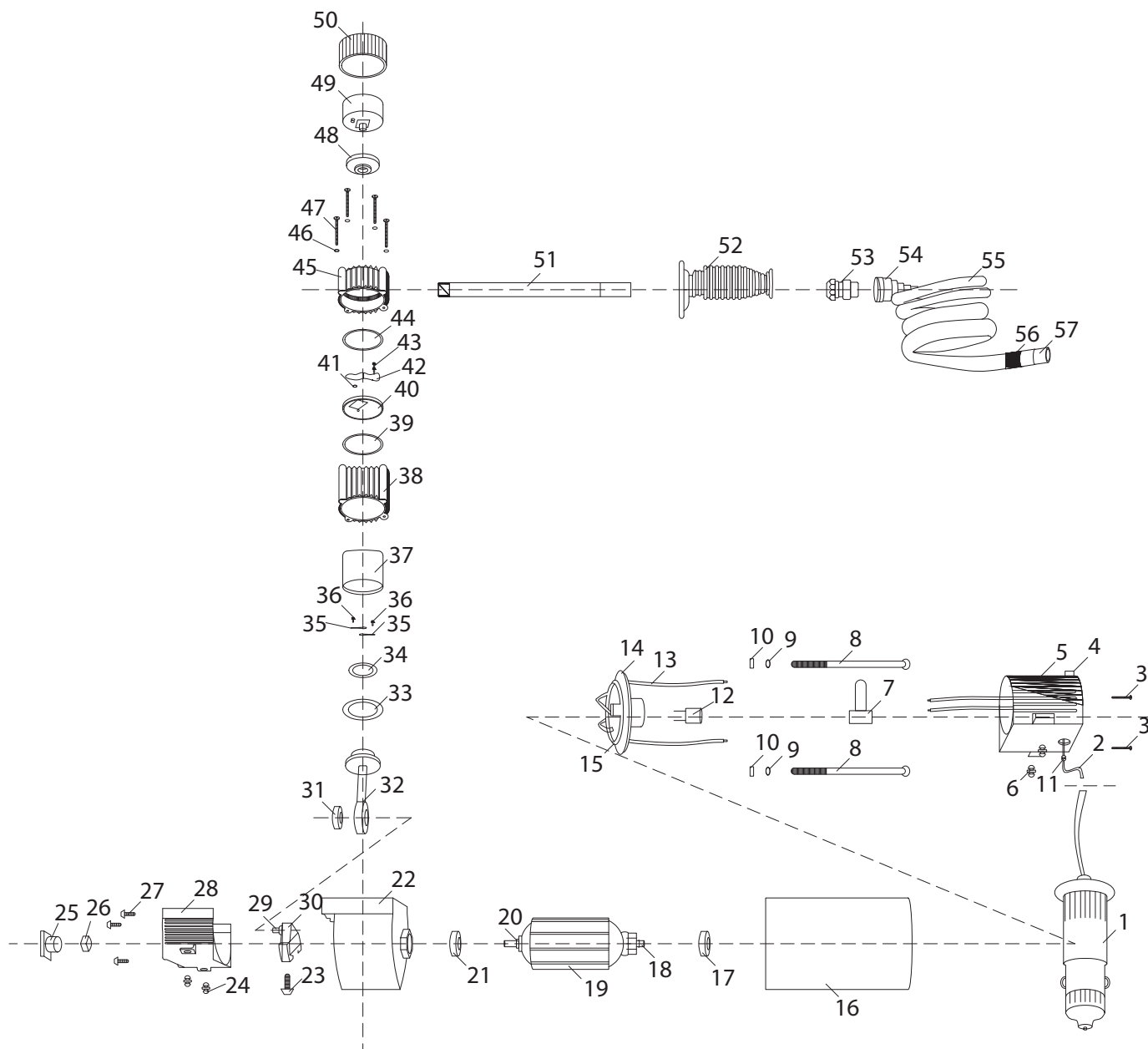

SAFETY

SETUP

OPERATION

MAINTENANCE

Record Product's Serial Number Here: _____

Note: If product has no serial number, record month and year of purchase instead.

Note: Some parts are listed and shown for illustration purposes only, and are not available individually as replacement parts.

Limited 90 Day Warranty

Harbor Freight Tools Co. makes every effort to assure that its products meet high quality and durability standards, and warrants to the original purchaser that this product is free from defects in materials and workmanship for the period of 90 days from the date of purchase. This warranty does not apply to damage due directly or indirectly, to misuse, abuse, negligence or accidents, repairs or alterations outside our facilities, criminal activity, improper installation, normal wear and tear, or to lack of maintenance. We shall in no event be liable for death, injuries to persons or property, or for incidental, contingent, special or consequential damages arising from the use of our product. Some states do not allow the exclusion or limitation of incidental or consequential damages, so the above limitation of exclusion may not apply to you. THIS WARRANTY IS EXPRESSLY IN LIEU OF ALL OTHER WARRANTIES, EXPRESS OR IMPLIED, INCLUDING THE WARRANTIES OF MERCHANTABILITY AND FITNESS.

To take advantage of this warranty, the product or part must be returned to us with transportation charges prepaid. Proof of purchase date and an explanation of the complaint must accompany the merchandise. If our inspection verifies the defect, we will either repair or replace the product at our election or we may elect to refund the purchase price if we cannot readily and quickly provide you with a replacement. We will return repaired products at our expense, but if we determine there is no defect, or that the defect resulted from causes not within the scope of our warranty, then you must bear the cost of returning the product.

This warranty gives you specific legal rights and you may also have other rights which vary from state to state.

PITTSBURGH[®] AUTOMOTIVE

3491 Mission Oaks Blvd. • PO Box 6009 • Camarillo, CA 93011 • (800) 444-3353