

Owner's Manual & Safety Instructions

Save This Manual Keep this manual for the safety warnings and precautions, assembly, operating, inspection, maintenance and cleaning procedures. Write the product's serial number in the back of the manual near the assembly diagram (or month and year of purchase if product has no number). Keep this manual and the receipt in a safe and dry place for future reference.

REV 15a

PREDATOR™ GENERATORS

13,500 WATT PORTABLE GENERATOR

11,000 RUNNING WATTS
13,500 PEAK WATTS



⚠ DANGER

Using a generator indoors **CAN KILL YOU IN MINUTES.**

Generator exhaust contains carbon monoxide. This is a poison you cannot see or smell.



NEVER use inside a home or garage, **EVEN IF** doors and windows are open.

Only use **OUTSIDE** and far away from windows, doors, and vents.

ITEM 61725

Visit our website at: <http://www.harborfreight.com>
Email our technical support at: productsupport@harborfreight.com
Email our engine support at: predator@harborfreight.com

When unpacking, make sure that the product is intact and undamaged. If any parts are missing or broken, please call 1-888-866-5797 as soon as possible.

⚠ WARNING

Read this material before using this product. Failure to do so can result in serious injury. SAVE THIS MANUAL.

Copyright© 2013 by Harbor Freight Tools®. All rights reserved.
No portion of this manual or any artwork contained herein may be reproduced in any shape or form without the express written consent of Harbor Freight Tools. Diagrams within this manual may not be drawn proportionally. Due to continuing improvements, actual product may differ slightly from the product described herein. Tools required for assembly and service may not be included.

Table of Contents

Specifications	2	Maintenance	20
Safety	3	Troubleshooting	24
Setup	8	Warranties	26
Operation	16	Parts Lists and Diagrams	28

Specifications

Generator	Output	120/240VAC, 60Hz, 1 Phase 11,000W Rated 13,500W Maximum
	Receptacles	See Figure A: Control Panel on page 8
Displacement		670cc
Engine Type		Horizontal Dual Cylinder 4-stroke
Cooling System		Forced air cooled
Fuel	Type	87+ octane stabilizer treated unleaded gasoline
	Capacity	7 Gallon
Engine Oil	Type SAE	10W-30 above 32° F 5W30 at 32° F or below SJ class oil
	Capacity	2 Quart
Run Time @ 50% Load with full tank		7.5 hr.
Sound Level at 3 feet		78 dB
Bore x Stroke		78 mm x 70 mm
Compression Ratio		7.93:1
Rotation viewed from PTO (power takeoff - the output shaft)		Counterclockwise
Spark Plug	Type	NGK® BP-6ES NHSP® / Torch® F6TC
	Gap	0.7 - 0.8 mm
Valve Clearance	Intake	0.10 - 0.15 mm
	Exhaust	0.15 - 0.20 mm
Speed	Idle	1800 RPM

The emissions control system for this Engine is warranted for standards set by the U.S. Environmental Protection Agency. For warranty information, refer to the last pages of this manual.



PREDATOR™



GENERATORS

WARNING SYMBOLS AND DEFINITIONS

	This is the safety alert symbol. It is used to alert you to potential personal injury hazards. Obey all safety messages that follow this symbol to avoid possible injury or death.
⚠ DANGER	Indicates a hazardous situation which, if not avoided, will result in death or serious injury.
⚠ WARNING	Indicates a hazardous situation which, if not avoided, could result in death or serious injury.
⚠ CAUTION	Indicates a hazardous situation which, if not avoided, could result in minor or moderate injury.
NOTICE CAUTION	Addresses practices not related to personal injury.

Symbol Definitions

Symbol	Property or Statement
RPM	Revolutions Per Minute
HP	Horsepower
	WARNING marking concerning Risk of Eye Injury. Wear ANSI-approved safety goggles with side shields.
	Read the manual before set-up and/or use.
	WARNING marking concerning Risk of Hearing Loss. Wear hearing protection.

Symbol	Property or Statement
	WARNING marking concerning Risk of Respiratory Injury. Operate engine OUTSIDE and far away from windows, doors, and vents.
	WARNING marking concerning Risk of Fire while handling fuel. Do not smoke while handling fuel.
	WARNING marking concerning Risk of Fire. Do not refuel while operating. Keep flammable objects away from engine.

IMPORTANT SAFETY INSTRUCTIONS



WARNING! Read all instructions.

Failure to follow all instructions listed below may result in fire, serious injury and/or DEATH.

The warnings and precautions discussed in this manual cannot cover all possible conditions and situations that may occur. It must be understood by the operator that common sense and caution are factors which cannot be built into this product, but must be supplied by the operator.

SAVE THESE INSTRUCTIONS

Set up Precautions

SAFETY

1. Gasoline fuel and fumes are flammable, and potentially explosive. Use proper fuel storage and handling procedures. Do not store fuel or other flammable materials nearby.
2. Have multiple ABC class fire extinguishers nearby.
3. Operation of this equipment may create sparks that can start fires around dry vegetation. A spark arrestor may be required. The operator should contact local fire agencies for laws or regulations relating to fire prevention requirements.
4. Set up and use only on a flat, level, well-ventilated surface.
5. All connections and conduits from the Generator to the load must only be installed by trained and licensed electricians, and in compliance with all relevant local, state, and federal electrical codes and standards, and other regulations where applicable.
6. Connections for standby power to a building electrical system must be made by a qualified electrician. The connection must isolate the generator power from utility power, and must comply with all applicable laws and electrical codes.
7. Wear ANSI-approved safety goggles, heavy-duty work gloves, and dust mask/respirator during set up.
8. Use only lubricants and fuel recommended in the Specifications chart of this manual.
9. Improper connections to a building electrical system can allow electrical current from the generator to backfeed into the utility lines. Such backfeed may electrocute utility company workers or others who contact the lines during a power outage, and the generator may explode, burn, or cause fires when utility power is restored. Consult the utility company and a qualified electrician if intending to use the generator for back up power.
10. Do not operate the Generator before grounding. The Generator must be earth-grounded in accordance with all relevant electrical codes and standards before operation.

SETUP

OPERATION

MAINTENANCE

Operating Precautions

1.  **CARBON MONOXIDE HAZARD**
Using a generator indoors
CAN KILL YOU IN MINUTES.
Generator exhaust contains carbon monoxide. This is a poison you cannot see or smell.

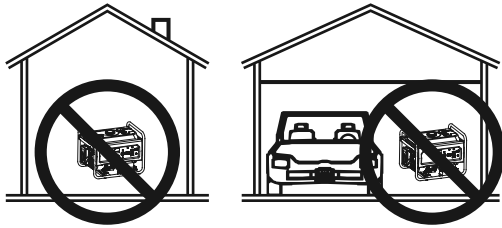

NEVER use inside a home or garage,
EVEN IF doors and windows are open.

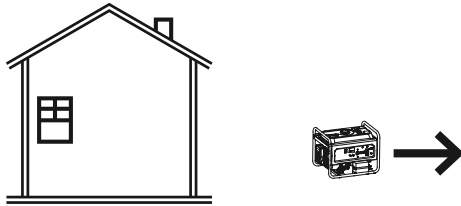

Only use OUTSIDE and far away from windows,
doors, and vents.

- Never use a generator indoors, including in garages, basements, crawl spaces and sheds. Opening doors and windows or using fans will NOT prevent carbon monoxide build up in the home.
- When using generators, keep them outdoors and far away from open doors, windows, and vents to avoid toxic levels of carbon monoxide from building up indoors.
- If you start to feel sick, dizzy, or weak while using a generator, get to fresh air right away. The carbon monoxide from generators can quickly lead to full incapacitation and death.
- Keep children away from the equipment, especially while it is operating.
- Keep all spectators at least six feet from the Engine during operation.
- Fire Hazard! Do not fill fuel tank while engine is running. Do not operate if gasoline has been spilled. Clean spilled gasoline before starting engine. Do not operate near pilot light or open flame.
- Do not touch engine during use. Let engine cool down after use.
- Never store fuel or other flammable materials near the engine.
- If the plugged in product operates abnormally or unusually slow, immediately stop using the generator as a power source. Read and adhere to the instruction manual of the product to be powered to make sure that it can be safely and efficiently powered by a portable generator.
- Before connecting an appliance or power cord to the generator: Make sure that it is in good working order. Faulty appliances or power cords can create a potential for electrical shock.
- Do not exceed the maximum power rating of the generator. Make sure that the total electrical rating of the all of the tools or appliances plugged into the generator at the same time does not exceed that of the generator. Check that the startup surge will not be beyond the limit of the Generator.
- Avoid substantially overloading which will trip the circuit breaker. Slightly overloading the generator may not trip the circuit breaker, but will lead to premature generator failure.
- Do not attempt to connect or disconnect load connections while standing in water, or on wet or soggy ground.
- Do not touch electrically energized parts of the Generator and interconnecting cables or conductors with any part of the body, or with any non-insulated conductive object.
- Connect the Generator only to a load that is compatible with the electrical characteristics and rated capacities of the Generator.
- Insulate all connections and disconnected wires.
- Guard against electric shock. Prevent body contact with grounded surfaces such as pipes, radiators, ranges, and refrigerators.
- Only use a suitable means of transport and lifting devices with sufficient weight bearing capacity when transporting the generator.
- Secure the generator on transport vehicles to prevent it from rolling, slipping, and tilting.
- Industrial applications must follow OSHA requirements.
- Do not leave the generator unattended when it is running. Turn off the generator (and remove safety keys, if available) before leaving the work area.
- The generator can produce high noise levels. Prolonged exposure to noise levels above 85 dBA is hazardous to hearing. Wear ear protection when operating the generator or when working nearby while it is operating.
- Wear ANSI-approved safety glasses and hearing protection during use.
- People with pacemakers should consult their physician(s) before use. Electromagnetic fields in close proximity to a heart pacemaker could cause pacemaker interference or pacemaker failure. Caution is necessary when near the engine's magneto or recoil starter.

Operating Precautions (cont.)

SAFETY

26. Use only accessories that are recommended by Harbor Freight Tools for your model. Accessories that may be suitable for one piece of equipment may become hazardous when used on another piece of equipment.
27. Do not operate in explosive atmospheres, such as in the presence of flammable liquids, gases, or dust. Gasoline-powered engines may ignite the dust or fumes.
28. Stay alert, watch what you are doing and use common sense when operating this generator. Do not use while tired or under the influence of drugs, alcohol or medication.

SETUP

29. Dress properly. Do not wear loose clothing or jewelry. Keep hair, clothing and gloves away from moving parts. Loose clothes, jewelry or long hair can be caught in moving parts.
30. Parts, especially exhaust system components, get very hot during use. Stay clear of hot parts.
31. Do not cover the generator during operation.
32. Keep the generator and surrounding area clean at all times.
33. Use the equipment, accessories, etc., in accordance with these instructions and in the manner intended for the particular type of equipment, taking into account the working conditions and the work to be performed. Use of the equipment for operations different from those intended could result in a hazardous situation.

OPERATION

MAINTENANCE

34. Do not operate the equipment with known leaks in the engine's fuel system.
35. **WARNING:** This product contains or, when used, produces a chemical known to the State of California to cause cancer and birth defects or other reproductive harm. (California Health & Safety Code § 25249.5, *et seq.*)
36. When spills of fuel or oil occur, they must be cleaned up immediately. Dispose of fluids and cleaning materials as per any local, state, or federal codes and regulations. Store oil rags in a bottom-ventilated, covered, metal container.
37. Keep hands and feet away from moving parts. Do not reach over or across equipment while operating.
38. Before use, check for misalignment or binding of moving parts, breakage of parts, and any other condition that may affect the equipment's operation. **If damaged, have the equipment serviced before using.** Many accidents are caused by poorly maintained equipment.
39. Use the correct equipment for the application. Do not modify the equipment and do not use the equipment for a purpose for which it is not intended.

Service Precautions

1. **Before service, maintenance, or cleaning:**
 - a. **Unplug all devices from the generator.**
 - b. **Turn the engine switch to its “OFF” position.**
 - c. **Allow the engine to completely cool.**
 - d. **Then, remove the spark plug cap from the spark plug.**
2. Keep all safety guards in place and in proper working order. Safety guards include muffler, air cleaner, mechanical guards, and heat shields, among other guards.
3. **Keep all electrical equipment clean and dry.** Replace any wiring where the insulation is cracked, cut, abraded, or otherwise degraded. Replace terminals that are worn, discolored, or corroded. Keep terminals clean and tight.
4. **Do not alter or adjust any part of the equipment or its engine that is sealed by the manufacturer or distributor. Only a qualified service technician may adjust parts that may increase or decrease governed engine speed.**
5. Wear ANSI-approved safety goggles, heavy-duty work gloves, and dust mask/respirator during service.
6. Maintain labels and nameplates on the equipment. These carry important information. If unreadable or missing, contact Harbor Freight Tools for a replacement.
7. Have the equipment serviced by a qualified repair person using only identical replacement parts. This will ensure that the safety of the equipment is maintained. Do not attempt any service or maintenance procedures not explained in this manual or any procedures that you are uncertain about your ability to perform safely or correctly.
8. Store equipment out of the reach of children.
9. Follow scheduled engine and equipment maintenance.

Refueling:

1. Do not smoke, or allow sparks, flames, or other sources of ignition around the equipment, especially when refuelling.
2. Do not refill the fuel tank while the engine is running or hot.
3. **Do not fill fuel tank to the top.** Leave a little room for the fuel to expand as needed.
4. Refuel in a well-ventilated area only.
5. Wipe up any spilled fuel and allow excess to evaporate before starting engine.
To prevent FIRE, do not start the engine while the smell of fuel hangs in the air.



SAVE THESE INSTRUCTIONS.

Set Up



Read the **ENTIRE IMPORTANT SAFETY INFORMATION** section at the beginning of this manual including all text under subheadings therein before set up or use of this product.

WARNING

TO PREVENT SERIOUS INJURY:

Operate only with proper spark arrestor installed.



Operation of this equipment may create sparks that can start fires around dry vegetation. A spark arrestor may be required.

The operator should contact local fire agencies for laws or regulations relating to fire prevention requirements.

Components and Controls

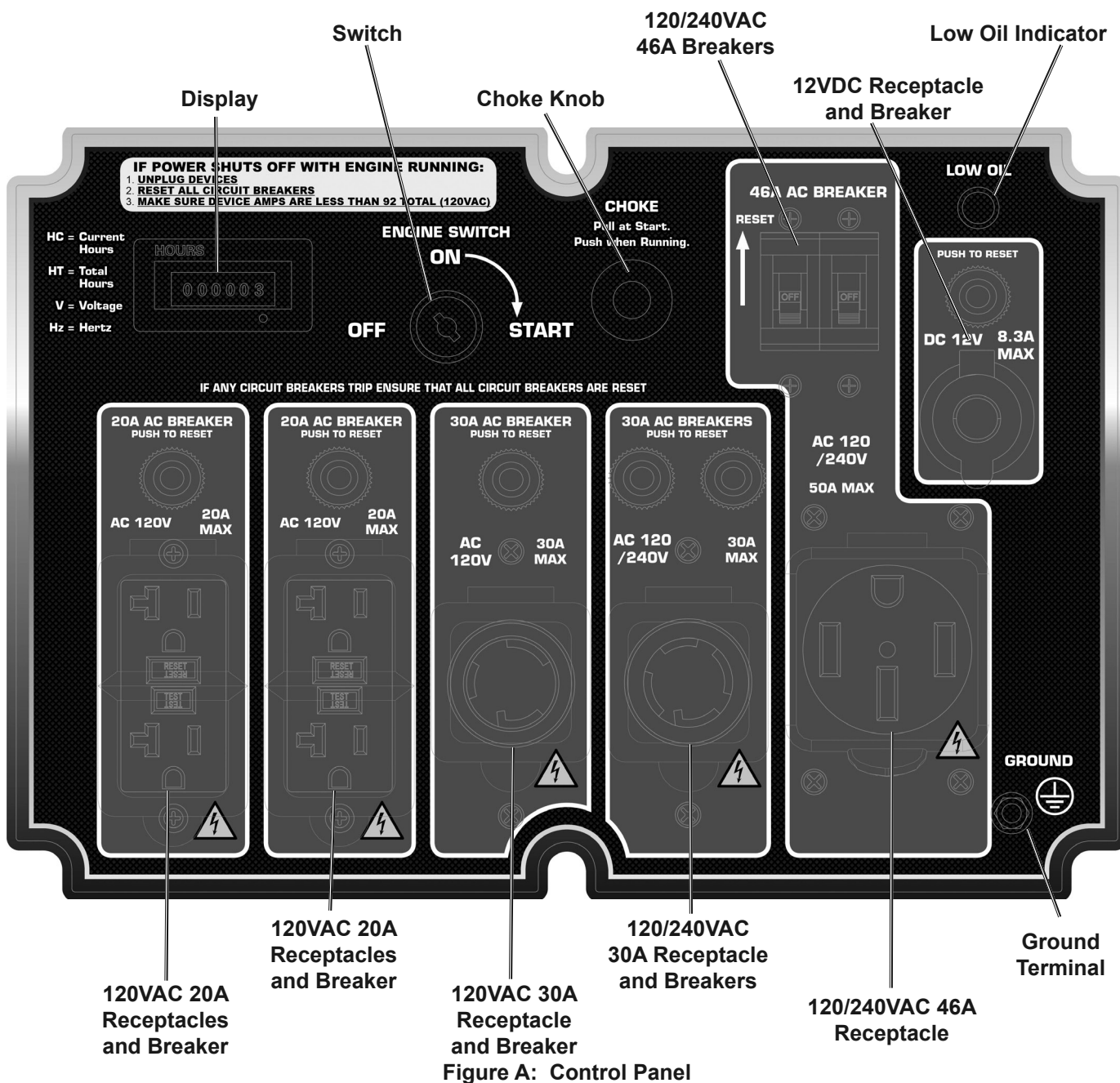

SAFETY

SETUP

OPERATION

MAINTENANCE

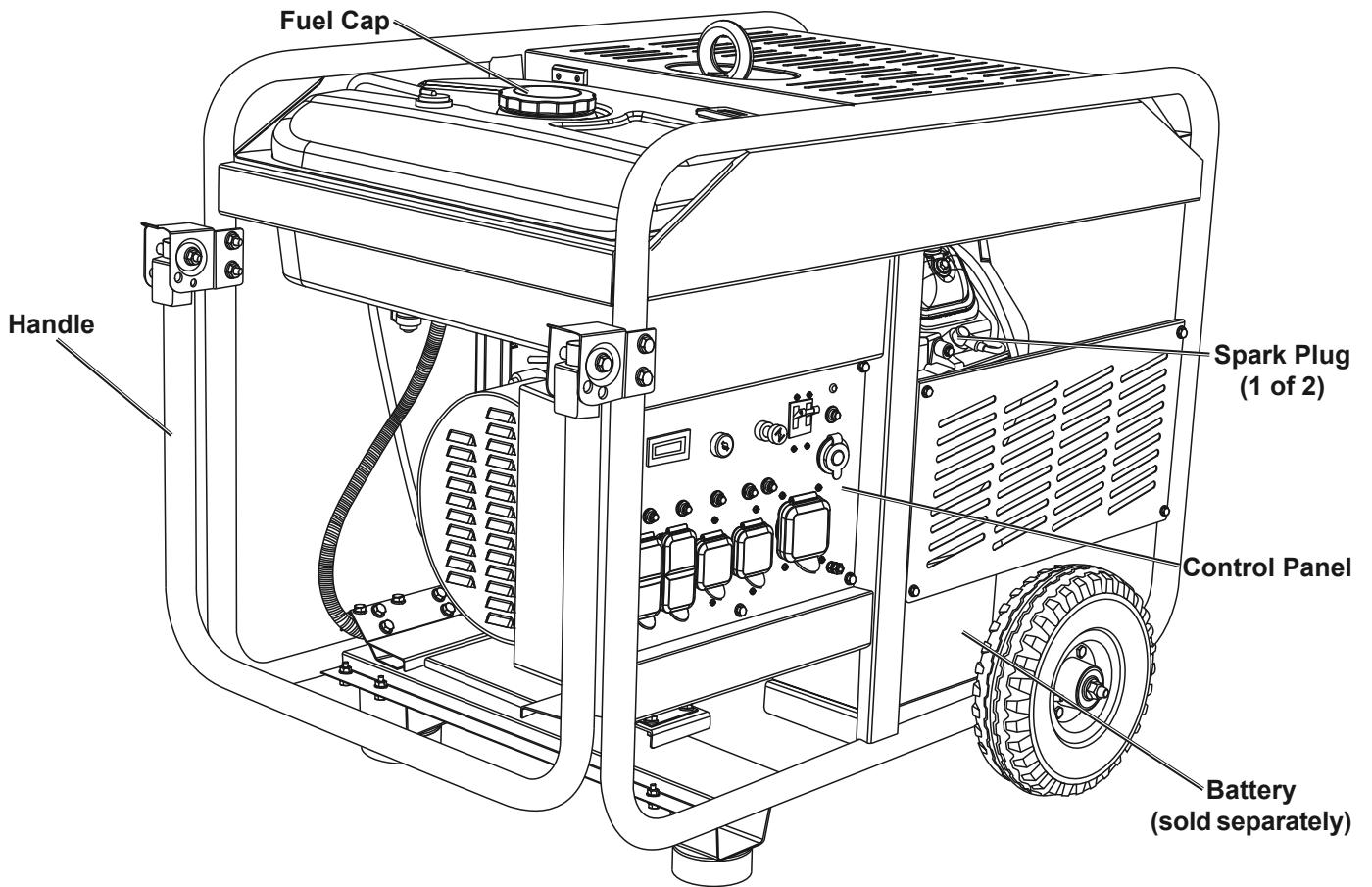

Figure B: Generator Front

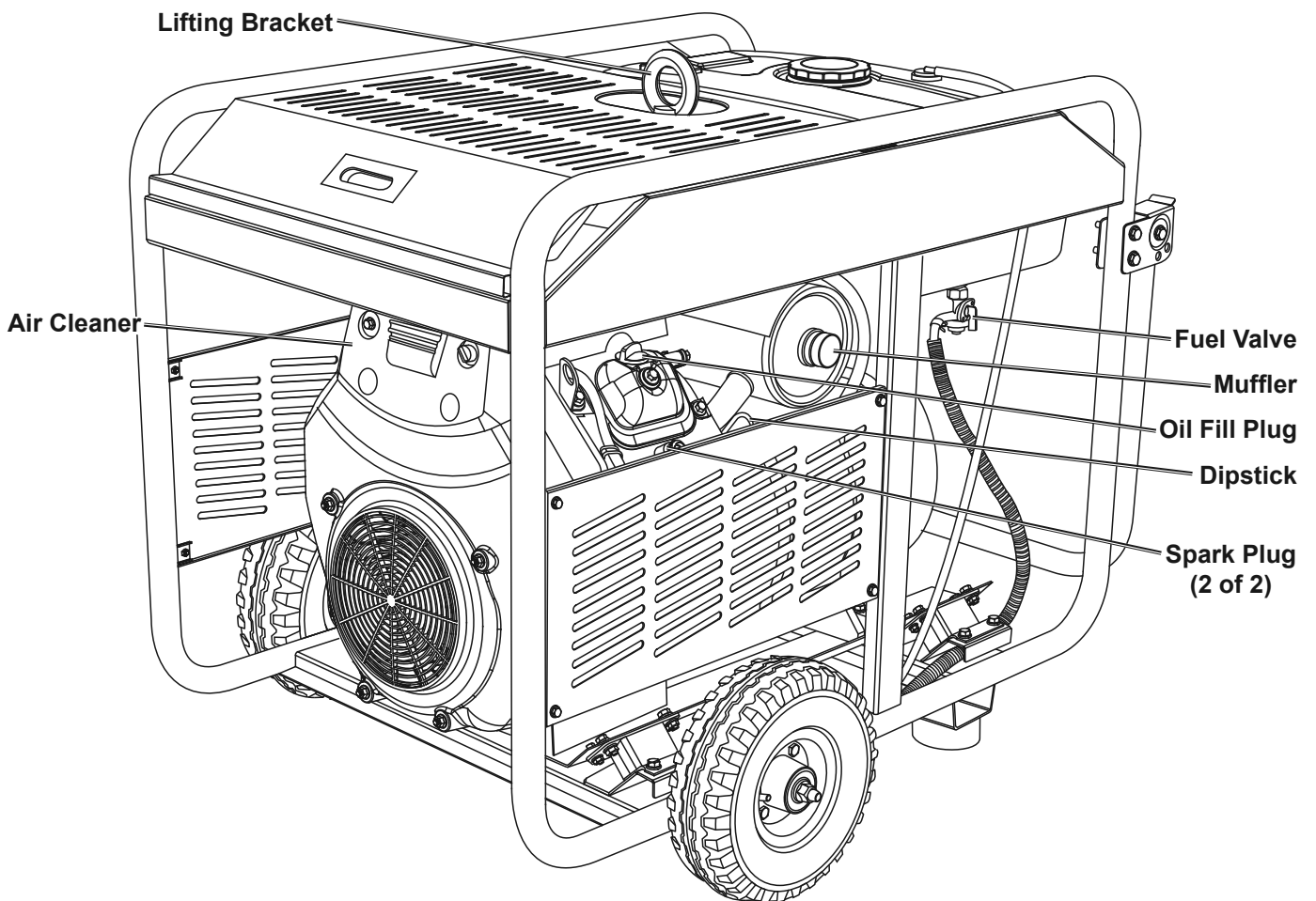

Figure C: Generator Back

High Altitude Operation Above 3000 feet

⚠️WARNING! TO PREVENT SERIOUS INJURY FROM FIRE:

Follow instructions in a well-ventilated area away from ignition sources.

If the engine is hot from use, shut the engine off and wait for it to cool before proceeding. Do not smoke.

NOTICE: Warranty void if necessary adjustments are not made for high altitude use.

At high altitudes, the engine's carburetor, governor, and any other parts that control the fuel-air ratio will need to be adjusted by a qualified mechanic to allow efficient high-altitude use and to prevent damage to the engine and any other devices used with this product. The fuel system on this engine may be influenced by operation at higher altitudes. Proper operation can be ensured by installing an altitude kit at altitudes higher than 3000 ft. above sea level. At elevations above 8000 ft, the engine may experience decreased performance, even with the proper main jet. Operating this engine without the proper altitude kit installed may increase the engine's emissions and decrease fuel economy and performance. The kit should be installed by a qualified mechanic.

High Altitude Kit Parts List - A

Part	Description	Qty
A1	Left Main Jet 3000-6000 ft.	1
A2	Right Main Jet 3000-6000 ft.	1
A3	Left Main Jet 6000-8000 ft.	1

Part	Description	Qty
A4	Right Main Jet 6000-8000 ft.	1
137d	Outer Bowl O-ring (replacement)	1
137e	Inner Bowl O-ring (replacement)	1

Disassembly

1. Turn off the engine.
2. Close the fuel valve.
3. Remove the Air Cleaner Top Knob (142a) and the two Air Cleaner Front Knobs (102). See Figure D.
4. Remove the Air Cleaner Front Cover (101), pulling it up then out. See Figure E.

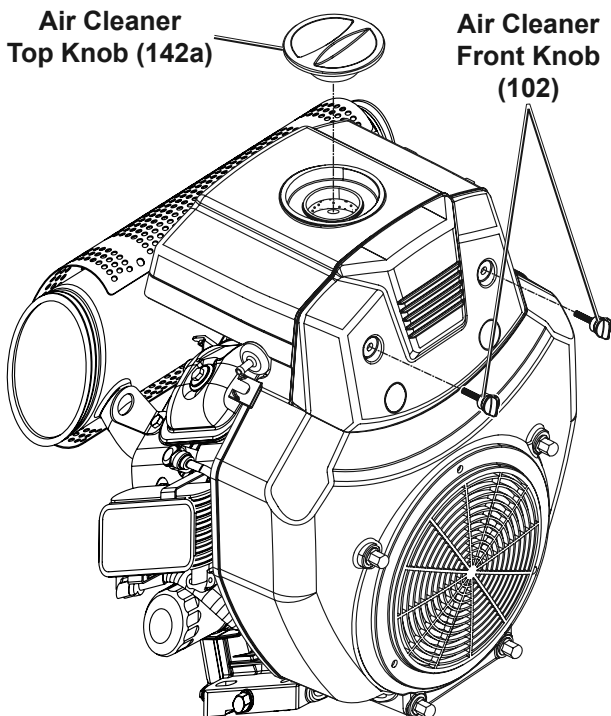

Figure D: Remove Knobs

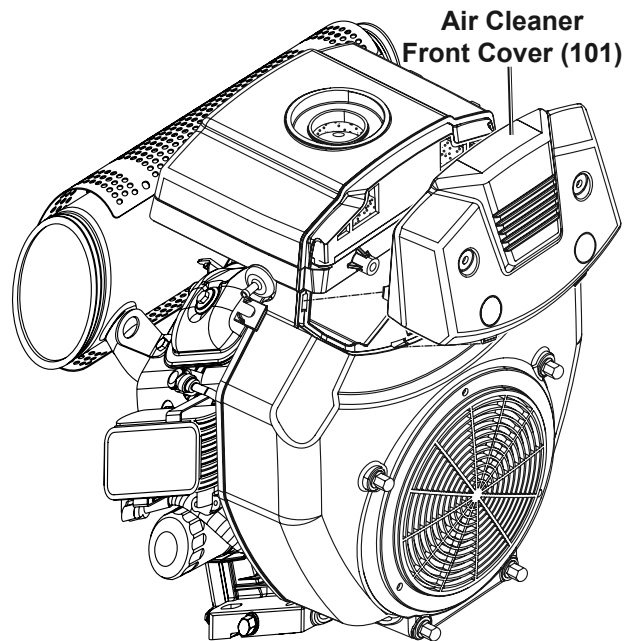

Figure E: Remove Front Cover

- Remove the Air Cleaner Top Cover (142b) and internal Air Cleaner components (Spacer, Foam and Paper Filters (142c-142e)). See Figure F.

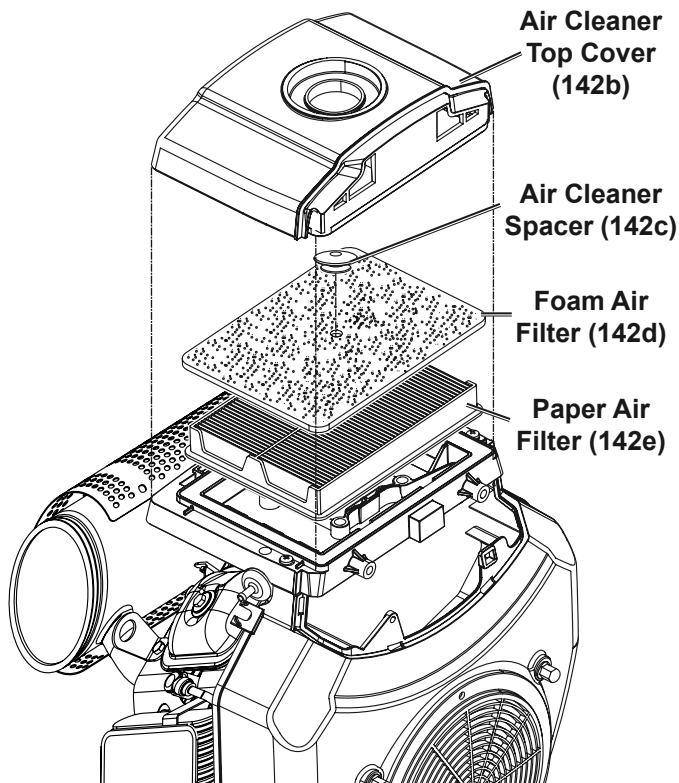

Figure F: Remove Air Cleaner Top Cover and components

- Remove the two Intake Cover Bolts (143) and the two Air Cleaner Base Bolts (146). See Figure G.
- Detach the top of the Fuel Filter Clip (147) from the Air Cleaner Base (142g).

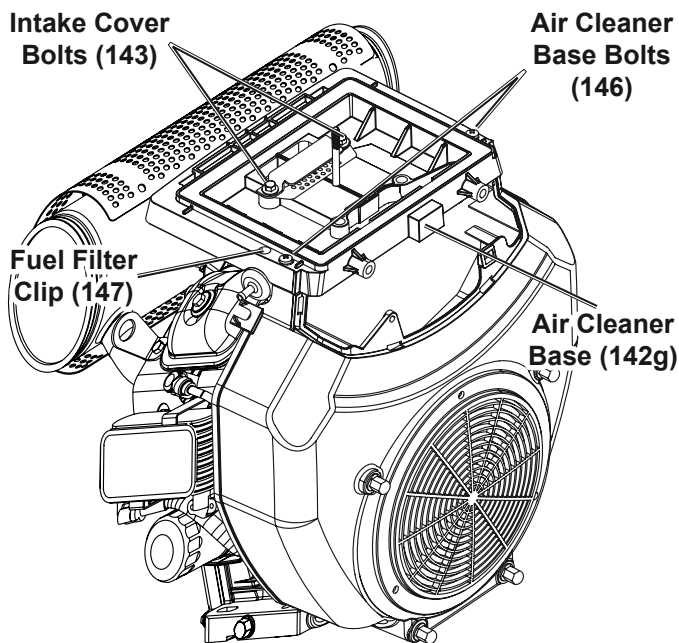
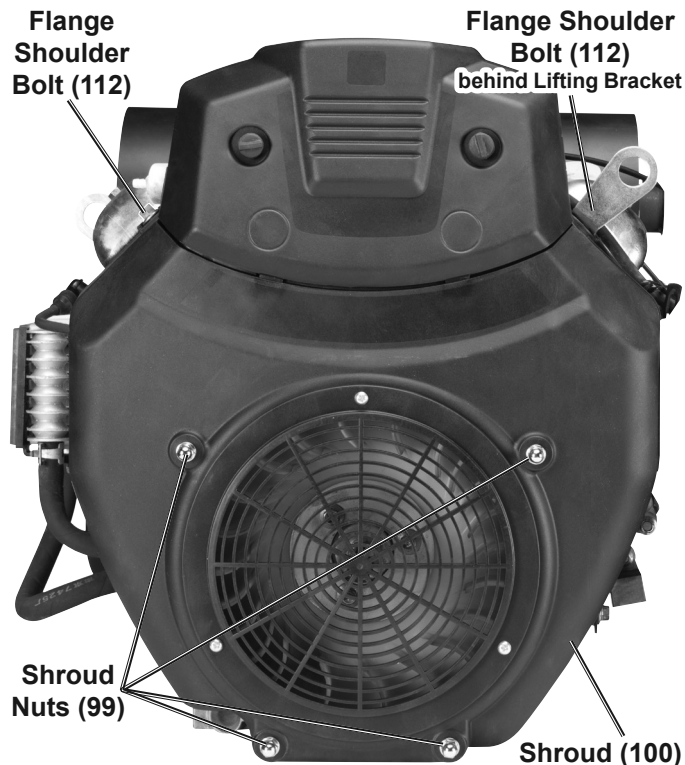

Figure G: Remove Bolts and Clip from Air Cleaner Base

- Remove the Air Cleaner Base.

- Remove the four Shroud Nuts (99) and the two Flange Shoulder Bolts (112) from the Shroud (100). The Flange Shoulder Bolt on the right holds the Lifting Bracket (111) in place. See Figure H.



Note: Air Cleaner Front Cover is still shown, although it should have been removed in step 4.

Figure H: Remove Shroud

- Remove the Shroud.

11. **WARNING! TO PREVENT SERIOUS INJURY FROM FIRE, BEFORE CONTINUING:**

- Make sure that the work area is well-ventilated and that there are no ignition sources.
- Have multiple class ABC fire extinguishers available.
- Double-check that fuel hose leading from fuel tank to Fuel Filter is clamped or fuel valve is closed.
- Use a safe, proper means to clean up all fuel spills immediately.



12. Squeeze the Spring Clamp (140) and slide it back. Detach the Fuel Hose (141) from the port at the top of the Carburetor. See Figure I.

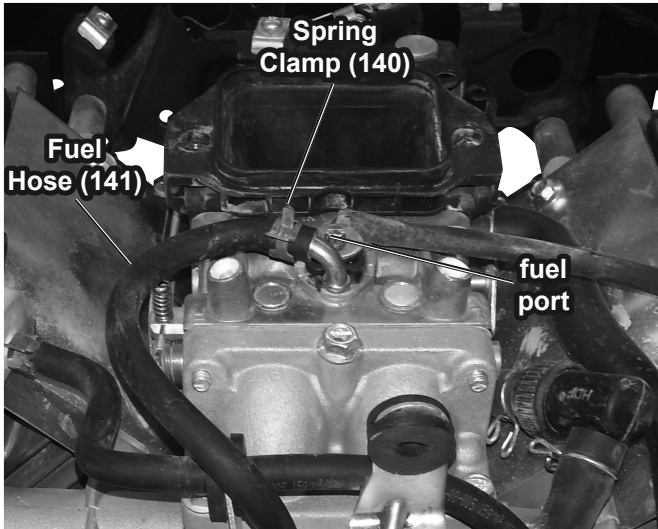

Figure I: Detach Fuel Hose

13. Locate the Throttle Rod (174) connection on the left side of the carburetor. See Figure J.

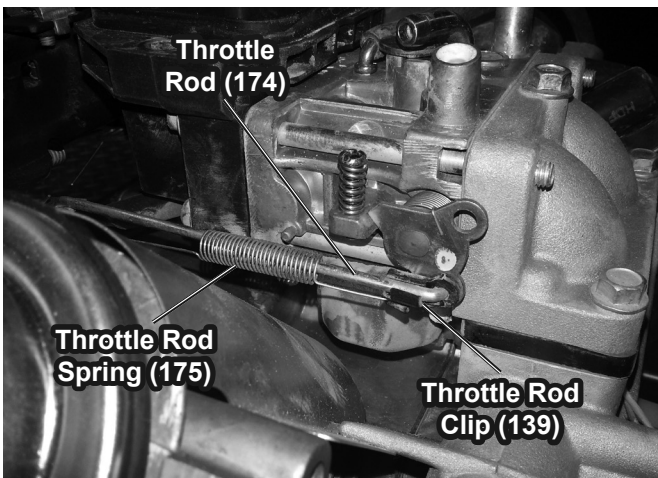

Figure J: Disconnect Throttle Rod

14. **A:** Swing the black Throttle Rod Clip (139) down to release the Throttle Rod. See Figure K.
B: Pull the Throttle Rod out of the Clip.

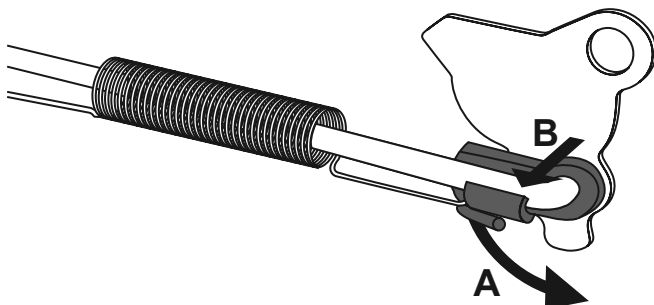

Figure K: Throttle Rod Clip

15. Disconnect the Throttle Rod Spring from the Throttle Rod Clip.

16. Squeeze the Spring Wire Clamp (32) and slide it back. Detach the Breather Hose (33) from the right side of the Carburetor. See Figure L.

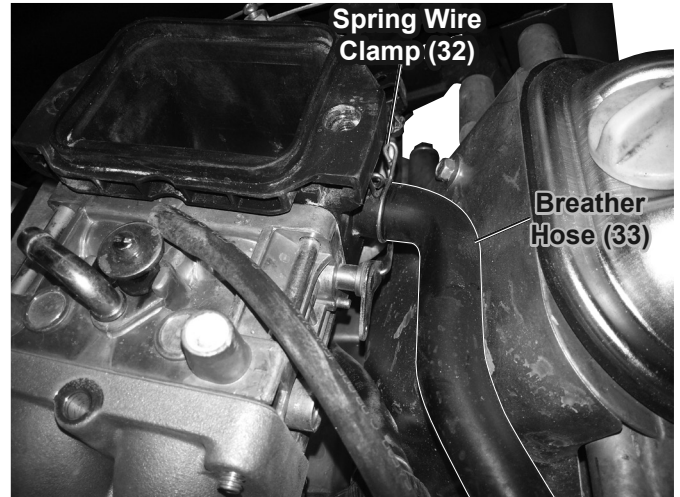

Figure L: Detach Breather Hose

17. Locate the Choke Rod (177) connection on the right side of the carburetor. See Figure M.

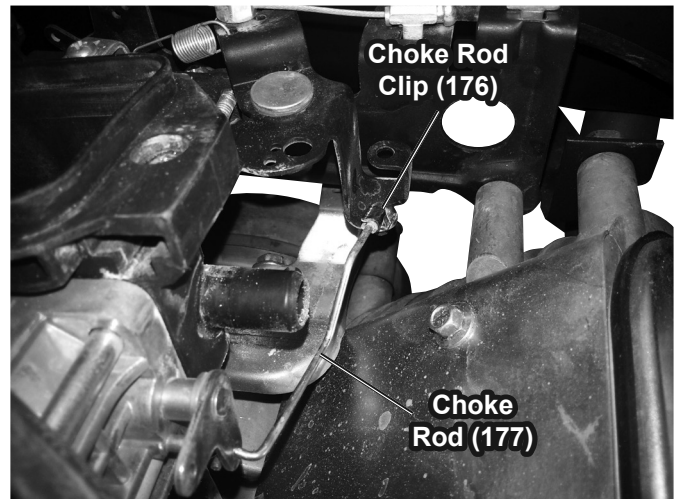

Figure M: Disconnect Choke Rod

18. Swing the black Choke Rod Clip (176) aside to release the Choke Rod. Disconnect the Choke Rod.

- At the front of the Carburetor, remove the Bolt (38) holding the Fuel Pump Bracket (40) in place. See Figure N.

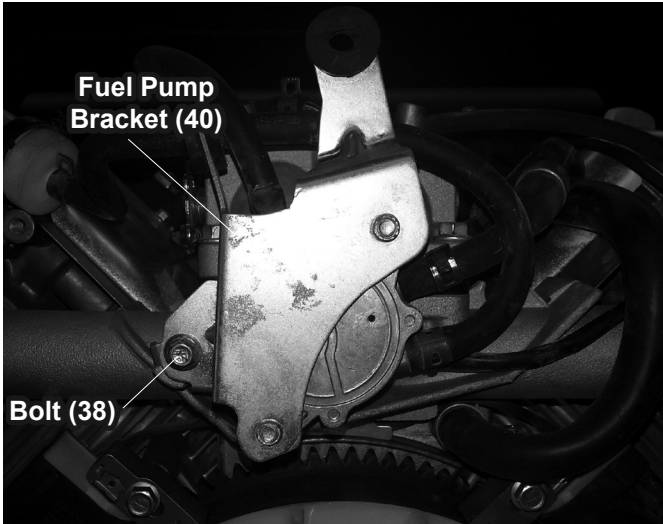

Figure N: Remove Fuel Pump Bracket

- Underneath where the Fuel Pump Bracket was, the Solenoid Valve (138) is connected. Note the location of the green wire and green dot on the connector. Unplug the connector. See Figure O.

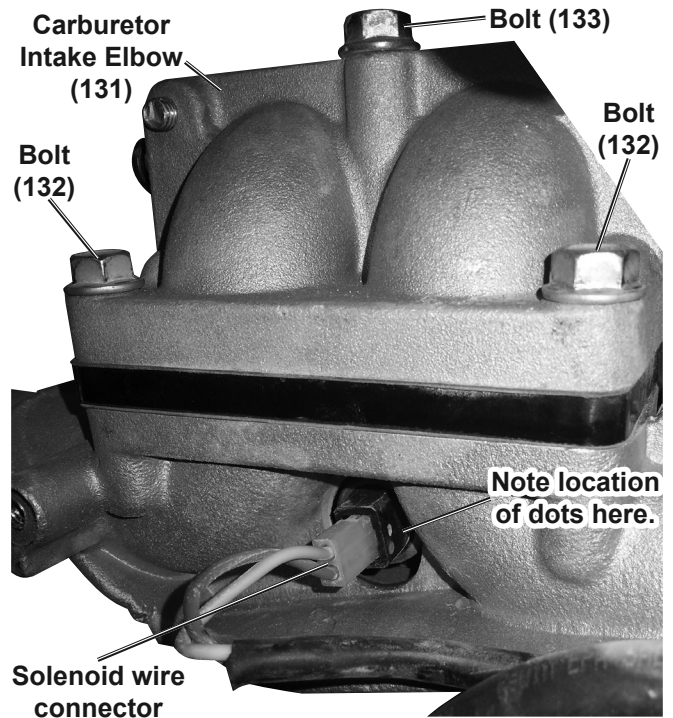

Figure O: Disconnect Solenoid Valve wire connector

- Remove Bolt (133) and two Bolts (132) from the Carburetor Intake Elbow (131). See Figure O.
- Remove the Carburetor assembly from the engine. Keep it upright, it may contain fuel.

23. Hold the fuel drain port over a bowl, and open the Carburetor Drain Plug (137a) to allow fuel to drain out of that port. Once the carburetor is empty, close the Carburetor Drain Plug. See Figure P.

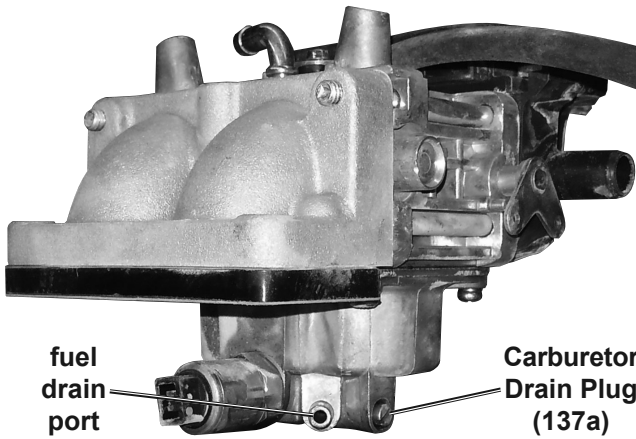

Figure P: Carburetor Drain

24. Turn the Carburetor assembly over.
25. Remove the four Carburetor Bowl Bolts (137b) and remove the Carburetor Bowl (137c). See Figure Q.

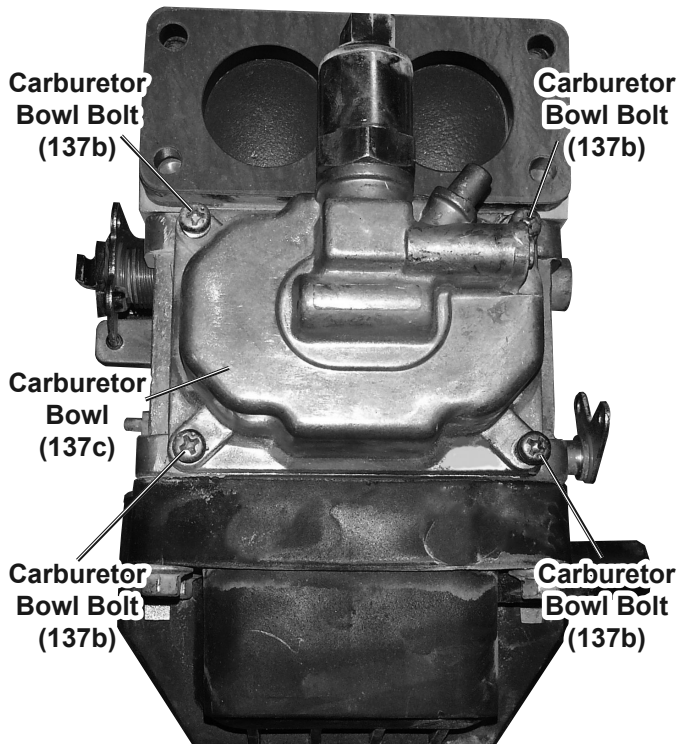
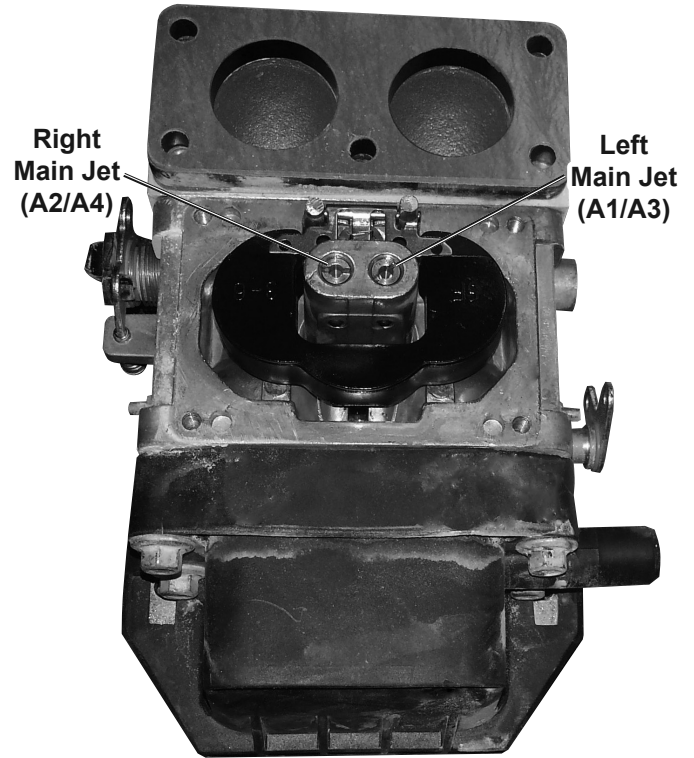

Figure Q: Carburetor Bowl Bolts

26. Use a carburetor screwdriver (sold separately) to remove the Left Main Jet and replace it with the proper replacement Left Main Jet (A1 or A3) for the altitude. See Figure R.
27. Use a carburetor screwdriver to remove the Right Main Jet and replace it with the replacement Right Main Jet (A2 or A4) for the same altitude as the Left Main Jet. See Figure R.



Note: Since carburetor is upside-down, left and right sides are reversed.

Figure R: Main Jets

PREDATOR™

GENERATORS

Reassembly

Note: Reassembly step references shown in brackets.

1. Replace the Outer and Inner Bowl O-rings (137d, 137e) with the replacements from the altitude kit. Do not reuse existing O-rings.

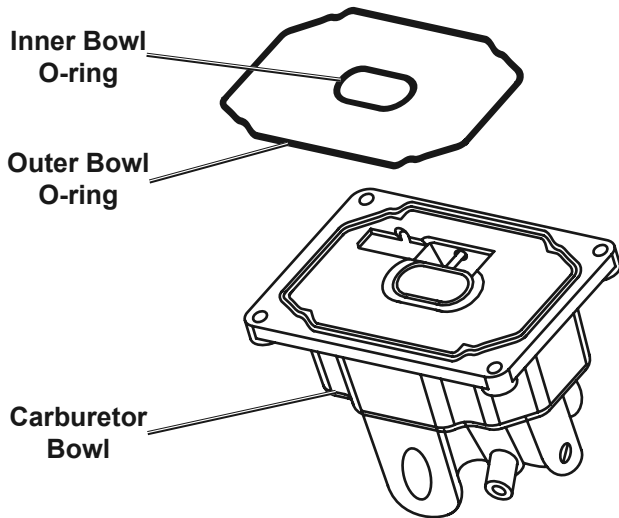

Figure S: Replace Bowl O-rings

2. Assemble the Carburetor Bowl using four Carburetor Bowl Bolts. [#25] Assemble Carburetor Intake Elbow to Intake using Bolts. [#21]
3. Attach Solenoid Valve connector, **line up green wire with the green dot on the connector.** [#20]
4. Attach Fuel Pump Bracket to front of intake using Bolt. Gently lift the Bracket after assembly to ensure proper alignment. [#19]

5. Attach the Choke Rod on the right side of the Carburetor, and secure it with its Clip. [#17,18]
6. Attach the Breather Hose to the Carburetor, and secure it with its Clamp. [#16]
7. Attach the Throttle Rod Spring to the Throttle Rod Clip on the left side of the Carburetor. [#15]
8. Insert the Throttle Rod on the left side of the Carburetor, and secure it with its Clip. [#14]
9. Attach the Fuel Hose to the port at the top of the Carburetor and attach it using its Clamp. [#12]
10. Install Shroud using four Shroud Bolts and two Flange Shoulder Bolts. [#9,10] Include the Lifting Bracket in place on the right Flange Shoulder Bolt.
11. Install Air Cleaner Base using two Air Cleaner Base Bolts. Connect Fuel Filter Clip under left side of Air Cleaner Base. Install the Intake Cover and Intake Screen using the Intake Cover Bolts. [#6-8]
12. Place the Paper Air Filter, Foam Air Filter, Air Cleaner Spacer, and Air Cleaner Top Cover into place on the Air Cleaner Base. [#5]
13. Replace the Air Cleaner Front Cover. [#4]
14. Use the Air Cleaner Top Knob and Air Cleaner Front Knobs to secure the Covers in place. [#3]
15. Once all connections are secure, open fuel valve.
16. Wipe up any spilled fuel and allow excess to evaporate before starting engine. To prevent FIRE, do not start the engine while the smell of fuel hangs in the air.

Battery Setup Instructions

1. Place a **fully charged**, lead-acid **12 volt, 36 Ah** battery (not included) in a stable, flat location near the engine.
2. Use provided battery cables only.
3. Attach the positive cable securely to the positive battery terminal to prevent disconnection and short circuits.
4. Attach the negative cable securely to the negative battery terminal to prevent disconnection and short circuits.
5. Coat the terminals and cable ends with a corrosion-preventive coating.

Grounding

1. The Generator must be properly grounded in accordance with all relevant electrical codes and standards before operation. Have the unit grounded by a qualified electrician if you are not qualified to do so.
2. To ground the Generator, connect a #XX AWG grounding wire (not included) from the Grounding Terminal on the Control Panel to a grounding rod (not included). The grounding rod must be an earth-driven copper or brass rod (electrode) which can adequately ground the Generator.
3. Refer to local regulations for ground source information.

Operation



Read the **ENTIRE IMPORTANT SAFETY INFORMATION** section at the beginning of this manual including all text under subheadings therein before set up or use of this product.

SAFETY

Pre-Start Checks

Inspect engine and equipment looking for damaged, loose, and missing parts before set up and starting. If any problems are found, do not use equipment until fixed properly.

Checking and Filling Engine Oil

NOTICE: Your Warranty is VOID if the engine's crankcase is not properly filled with oil before each use. Before each use, check the oil level. Do not run the engine with low or no engine oil. Running the engine with no or low engine oil WILL permanently damage the engine.

1. Make sure the engine is stopped and is level.
2. Close the Fuel Valve.
3. On the back of the Generator, pull the Dipstick out, and wipe its end off with a clean, lint free rag.
4. Reinsert the Dipstick fully and remove it to check the oil level. The oil level should be up to the full level as shown in Figure U.
5. If the oil level is at or below the low mark:
 - a. Clean the top of the yellow Oil Fill Cap and the area around it.
 - b. Remove the Oil Fill Cap by turning it counterclockwise.
 - c. Add the appropriate type of oil until the oil level is at the proper level. SAE 10W-30 oil is recommended for general use. (Table A: SAE Viscosity Grades on page 21 in the Maintenance section shows other viscosities to use in different average temperatures.)
6. Thread the Oil Fill Cap back in and reinsert the Dipstick.

NOTICE: Do not run the engine with too little oil. The engine will be permanently damaged.

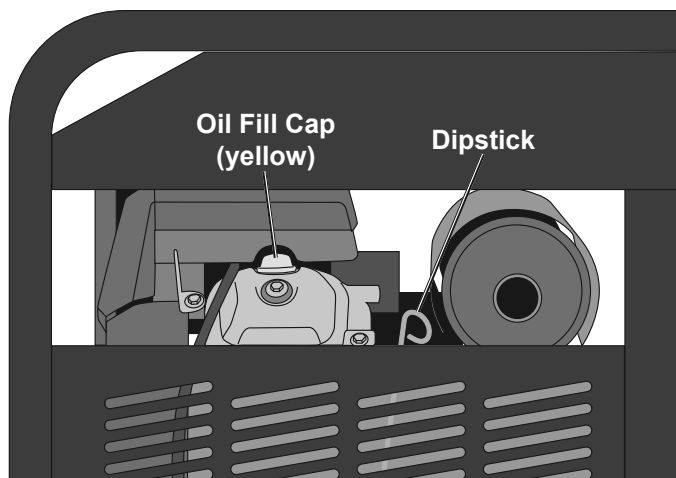

Figure T: Oil Fill Cap and Dipstick (on back of Generator)

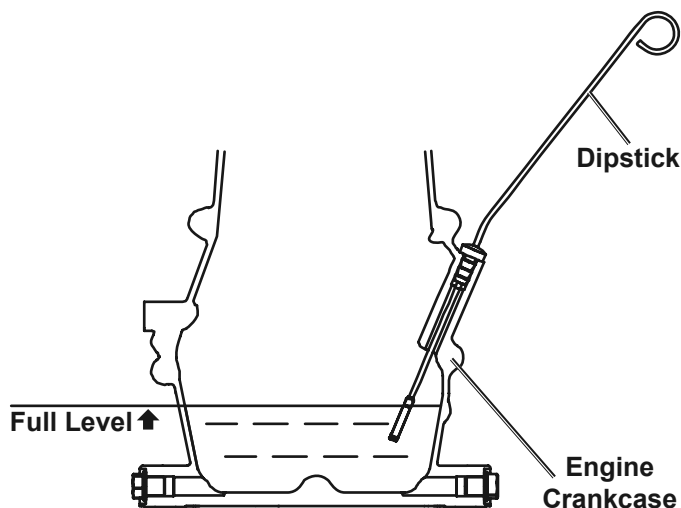

Figure U: Oil Fill Level

PREDATOR™

GENERATORS

SETUP

OPERATION

MAINTENANCE

Checking and Filling Fuel



⚠ WARNING! TO PREVENT SERIOUS INJURY FROM FIRE:

Fill the fuel tank in a well-ventilated area away from ignition sources. If the engine is hot from use, shut the engine off and wait for it to cool before adding fuel.

Do not smoke.

1. Clean the Fuel Cap and the area around it.
2. Unscrew and remove the Fuel Cap.
3. If needed, fill the Fuel Tank to about 1 inch under the fill neck of the Fuel Tank with 87 octane or higher unleaded gasoline that has been treated with a fuel stabilizer additive. Follow fuel stabilizer manufacturer's recommendations for use.

Note: Do not use gasoline containing more than 10% ethanol (E10). Do not use E85 ethanol.

Note: Do not use gasoline that has been stored in a metal fuel container or a dirty fuel container. It can cause particles to enter the carburetor, effecting engine performance and/or causing damage.

4. Then replace the Fuel Cap.
5. Wipe up any spilled fuel and allow excess to evaporate before starting engine. To prevent FIRE, do not start the engine while the smell of fuel hangs in the air.

PREDATOR™ GENERATORS

Starting the Engine

SAFETY



Before starting the engine:

- Inspect the generator and engine.
- Disconnect all electrical loads from the generator.
- Fill the engine with the proper amount and type of both unleaded gasoline and oil.

SETUP

- To start a cold engine, pull the START Knob out to the START position.
To restart a warm engine, push the START Knob in to the RUN position.

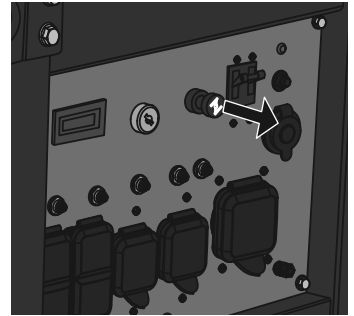
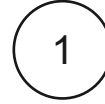

- Open the Fuel Valve.

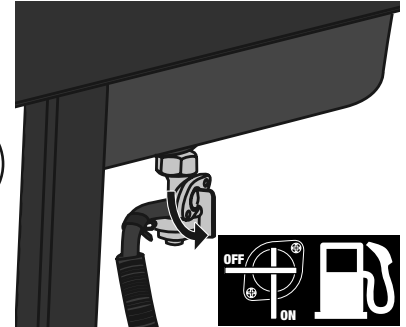

OPERATION

- Turn the Engine Switch to START.

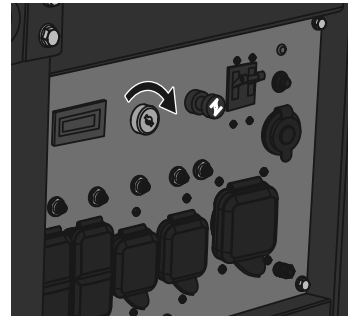
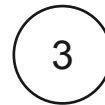
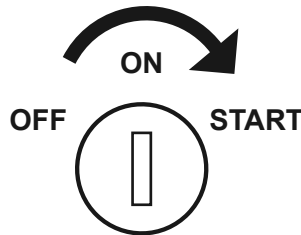

- Allow the Engine to run for several seconds.
Then, if the START lever is in the START position, move the START Lever very slowly to its RUN position.

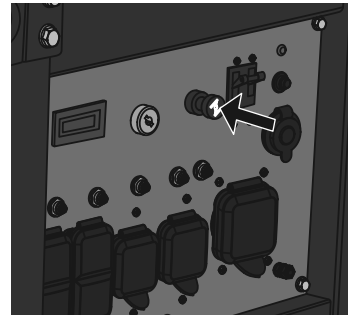

Note: Moving the START Lever too fast could stall the engine.

IMPORTANT: Allow the engine to run at no load for five minutes with no load after each start-up so that the engine can stabilize.

- Adjust the Throttle as needed.

Break-in Period:

- Breaking-in the engine will help to ensure proper equipment and engine operation.
- The break-in period will last about 25 hours of use. **DO NOT** exceed 75% of the Generator's rated capacity during this period.
 - Change the engine oil after this period.

Under normal operating conditions subsequent maintenance follows the schedule explained in the MAINTENANCE section.

MAINTENANCE

Connecting Loads to the Generator

Load and Circuit Breaker:

1. The total combined load through the outlet on the Generator must not exceed the rated maximum power of the unit.
2. Reduce the load if the AC Circuit Breaker turns off. Once the load is reduced, press the Circuit Breaker Button to reset the Generator and continue operation.

Calculate Power Draw:

Power draw can be calculated by multiplying *volts* and *amps*. The resulting number is *wattage*.

- Never exceed the rated maximum wattage for the Generator or any outlet amperage rating.
- Refer to appliance/tool owner's manuals to determine the wattage of electrical load devices.
- Long power cords and extension cords draw additional power. Keep cord length at a minimum.

Wattage Estimates

Wattages listed below are estimates for that type of equipment only. Check nameplate wattages on all loads before connecting to Generator.

This Unit Can Power Any One of the Following Items:	Running Watts	Start-up Watts
1/4 HP Air Compressor	600	900
1/6 HP Motor	500	800
3/8" Drill	400	600
Mini Refrigerator	400	700
Table/Box Fan	200	
15 Amp Battery Charger	380	
String Trimmer	350	
Hedge Trimmer	500	
Radio	50	
Ten 75 Watt Light Bulbs	750	

3. Allow the Engine to run at no load for five minutes after each start-up to allow the Engine to stabilize.

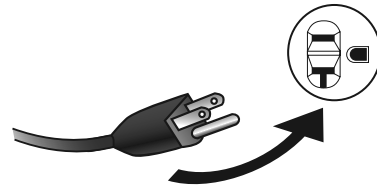

Figure V: Plug Load In

4. Plug the power cord of the 120 volt appliance/tool into the 120 volt AC Outlet on the Generator.

Note: Do not allow the generator to completely run out of fuel with devices attached. A generator's output may sharply spike as it runs out of fuel, causing damage to attached devices.

Stopping the Engine

1. To stop the engine in an emergency, turn the Engine Switch off.
2. Under normal conditions, use the following procedure:
 - a. Remove all electrical load devices from the Generator.
 - b. Turn the Engine Switch off.
 - c. Close the Fuel Valve.

NOTICE

See Long-Term Storage on page 23 for complete storage instructions.

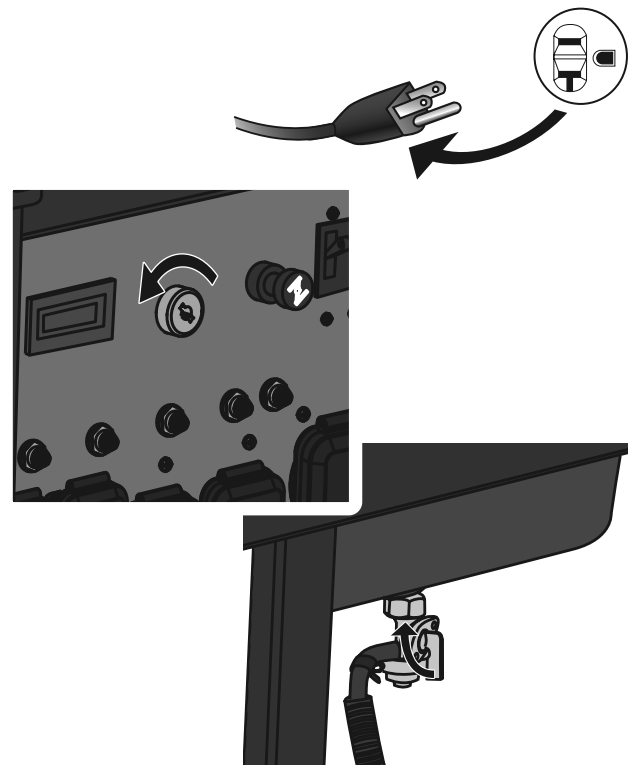

⚠ WARNING

TO PREVENT SERIOUS INJURY FROM ACCIDENTAL STARTING:

Turn the Power Switch of the equipment to its “OFF” position, wait for the engine to cool, and disconnect the spark plug cap before performing any inspection, maintenance, or cleaning procedures.

TO PREVENT SERIOUS INJURY FROM EQUIPMENT FAILURE:

Do not use damaged equipment. If abnormal noise, vibration, or excess smoking occurs, have the problem corrected before further use.

Follow all service instructions in this manual. The engine may fail critically if not serviced properly.



Many maintenance procedures, including any not detailed in this manual, will need to be performed by a qualified technician for safety. If you have any doubts about your ability to safely service the equipment or engine, have a qualified technician service the equipment instead.

Cleaning, Maintenance, and Lubrication Schedule

Note: This maintenance schedule is intended solely as a general guide. If performance decreases or if equipment operates unusually, check systems immediately. The maintenance needs of each piece of equipment will differ depending on factors such as duty cycle, temperature, air quality, fuel quality, and other factors.

Note: The following procedures are in addition to the regular checks and maintenance explained as part of the regular operation of the engine and equipment.

Procedure	Before Each Use	Monthly or every 20 hr. of use	Every 3 mo. or 50 hr. of use	Every 6 mo. or 100 hr. of use	Yearly or every 300 hr. of use	Every 2 Years
Brush off outside of engine	✓	✓	✓	✓	✓	✓
Check engine oil level	✓	✓	✓	✓	✓	✓
Check air cleaner			✓	✓	✓	✓
Check sediment cup				✓	✓	✓
Change engine oil		✓		✓	✓	✓
Clean air filter			✓*	✓	✓	✓
Check and clean spark plug				✓	✓	✓
1. Check/adjust idle speed 2. Check/adjust valve clearance 3. Clean fuel tank, strainer and carburetor 4. Clean carbon build-up from combustion chamber					✓**	✓**
Replace fuel line if necessary						✓**

*Service more frequently when used in dusty areas.

**These items should be serviced by a qualified technician.

PREDATOR™
GENERATORS

Checking and Filling Fuel



⚠️ WARNING! TO PREVENT SERIOUS INJURY FROM FIRE:

Fill the fuel tank in a well-ventilated area away from ignition sources. If the engine is hot from use, shut the engine off and wait for it to cool before adding fuel. Do not smoke.

1. Clean the Fuel Cap and the area around it.
2. Unscrew and remove the Fuel Cap.
3. Remove the Strainer and remove any dirt and debris. Then replace the Strainer.

Note: Do not use gasoline containing more than 10% ethanol (E10). Do not use E85 ethanol. Add fuel stabilizer to the gasoline or the Warranty is VOID.

Note: Do not use gasoline that has been stored in a metal fuel container or a dirty fuel container. It can cause particles to enter the carburetor, affecting engine performance and/or causing damage.

4. If needed, fill the Fuel Tank to about 1 inch under the fill neck of the Fuel Tank with 87 octane or higher unleaded gasoline that has been treated with a fuel stabilizer additive. Follow fuel stabilizer manufacturer's recommendations for use.
5. Then replace the Fuel Cap.
6. Wipe up any spilled fuel and allow excess to evaporate before starting engine. To prevent FIRE, do not start the engine while the smell of fuel hangs in the air.

Engine Oil Change

⚠️ CAUTION! Oil is very hot during operation and can cause burns. Wait for engine to cool before changing oil.

1. Make sure the engine is stopped and is level.
2. Close the Fuel Valve.
3. Place a drain pan (not included) underneath the crankcase's drain plug.
4. Remove the drain plug and allow the oil to drain out. Recycle used oil.
5. Replace the drain plug and tighten it.

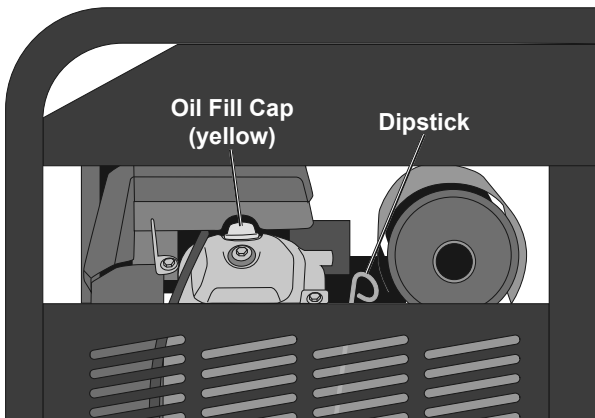

Figure W: Oil Fill Cap and Dipstick (on back of Generator)

6. On the back of the Generator, pull the Dipstick out, and wipe its end off with a clean, lint free rag.

7. Reinsert the Dipstick fully and remove it to check the oil level. The oil level should be up to the full level as shown in Figure X.

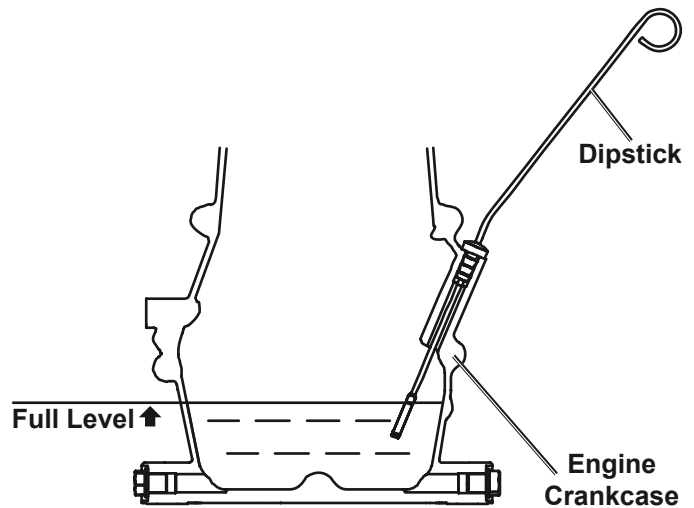

Figure X: Oil Fill Level

8. If the oil level is at or below the low mark:
 - a. Clean the top of the yellow Oil Fill Cap and the area around it.
 - b. Remove the Oil Fill Cap by turning it counterclockwise.
 - c. Add the appropriate type of oil until the oil level is at the proper level. SAE 10W-30 oil is recommended for general use. The SAE Viscosity Grade chart shows other viscosities to use in different average temperatures.

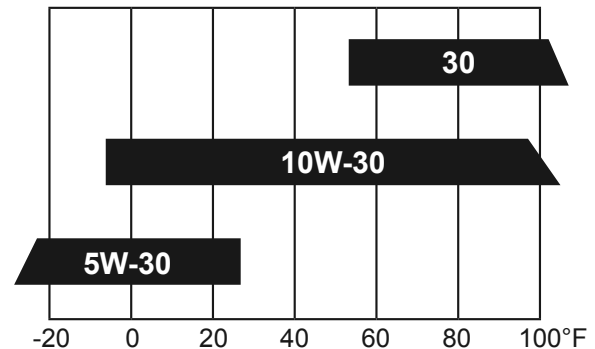

Table A: SAE Viscosity Grades

9. Thread the Oil Fill Cap back in and reinsert the Dipstick.

NOTICE: Do not run the engine with too little oil. The engine will be permanently damaged.

Air Filter Maintenance

1. Remove the Air Cleaner Cover and the air filters and check for dirt. Clean as described below.
2. **Cleaning:**
 - For paper filters:
To prevent injury from dust and debris, wear ANSI-approved safety goggles, NIOSH-approved dust mask/respirator, and heavy-duty work gloves. In a well-ventilated area away from bystanders, use pressurized air to blow dust out of the filter.
 - For foam filters:
Wash the filter in warm water and mild detergent several times. Rinse. Squeeze out excess water and allow it to dry completely. Soak the filter in lightweight oil briefly, then squeeze out the excess oil.
3. Install the cleaned filters. Secure the Air Cleaner Cover before use.

Spark plug Maintenance

1. Disconnect spark plug caps from end of plugs. Clean out debris from around spark plugs.
2. Using a spark plug wrench, remove the spark plugs.
3. Inspect the spark plugs:
If the electrode is oily, clean it using a clean, dry rag. If the electrode has deposits on it, polish it using emery paper. If the white insulator is cracked or chipped, the spark plug needs to be replaced.

Recommended Spark Plugs	
NGK®	BP-6ES
NHSP® / TORCH®	F6TC

NOTICE: Using an incorrect spark plug may damage the engine.

4. When installing a new spark plug, adjust the plug's gap to the specification on the Specifications chart. Do not pry against the electrode, the spark plug can be damaged.
 5. Install the new spark plugs or the cleaned spark plugs into the engine.
 - **Gasket-style:**
Finger-tighten until the gasket contacts the cylinder head, then tighten about 1/2-2/3 turn more.
 - **Non-gasket-style:**
Finger-tighten until the plug contacts the cylinder head, then tighten about 1/16 turn more.
- NOTICE:** Tighten the spark plugs properly. **If loose**, the spark plugs will cause the engine to overheat. **If overtightened**, the threads in the engine block will be damaged.
6. Apply dielectric spark plug boot protector (not included) to the end of the spark plugs and reattach the wires securely.

Long-Term Storage

When the equipment is to remain idle for longer than 20 days, prepare the engine for storage as follows:

1. **CLEANING:**

Wait for engine to cool, then clean engine with dry cloth. **NOTICE: Do not clean using water.** The water will gradually enter the engine and cause rust damage. Apply a thin coat of rust preventive oil to all metal parts.

2. **FUEL:**

To protect the fuel tank during storage, fill the tank with gasoline that has been treated with a fuel stabilizer additive. Follow fuel stabilizer manufacturer's recommendations for use. Refer to *Checking and Filling Fuel* on page 23.



⚠️ WARNING! TO PREVENT SERIOUS INJURY FROM FIRE:

Fill tank in a well-ventilated area away from ignition sources. If the engine is hot from use, shut the engine off and wait for it to cool before adding fuel. Do not smoke.

3. **LUBRICATION:**

- Change engine oil.
- Clean out area around spark plug.
Remove spark plug and pour one tablespoon of engine oil into cylinder through spark plug hole.

- Replace spark plug, but leave spark plug cap disconnected.
 - Pull Starter Handle to distribute oil in cylinder. Stop after one or two revolutions when you feel the piston start the compression stroke (when you start to feel resistance).
- ## 4. **BATTERY:**
- Disconnect battery cables (if equipped). Recharge batteries monthly while in storage.
- ## 5. **STORAGE AREA:**
- Cover and store in a dry, level, well-ventilated area out of reach of children. Storage area should also be away from ignition sources, such as water heaters, clothes dryers, and furnaces.

NOTICE: During extended storage periods the Engine must be started every 3 months and allowed to run for 15–20 minutes or the Warranty is VOID.

6. **AFTER STORAGE:**

Before starting the engine during or after storage, keep in mind that untreated gasoline will deteriorate quickly. Drain the fuel tank and change to fresh fuel if untreated gasoline has been sitting for a month, if treated gasoline has been sitting beyond the fuel stabilizer's recommended time period, or if the engine does not start.

PREDATOR™ GENERATORS

Troubleshooting

SAFETY

SETUP

OPERATION

MAINTENANCE

Problem	Possible Causes	Probable Solutions
Engine will not start	<p>FUEL RELATED:</p> <ol style="list-style-type: none"> No fuel in tank or fuel valve closed. START not in START position, cold engine. Gasoline with more than 10% ethanol used. (E15, E20, E85, etc.) Low quality or deteriorated, old gasoline. Carburetor not primed. Dirty fuel passageways. Carburetor needle stuck. Fuel can be smelled in the air. Too much fuel in chamber. This can be caused by the carburetor needle sticking. Clogged Fuel Filter. 	<p>FUEL RELATED:</p> <ol style="list-style-type: none"> Fill fuel tank with fresh 87+ octane stabilizer-treated unleaded gasoline and open fuel valve. Do not use gasoline with more than 10% ethanol (E15, E20, E85, etc.). Move START to START position. Clean out ethanol rich gasoline from fuel system. Replace components damaged by ethanol. Use fresh 87+ octane stabilizer-treated unleaded gasoline only. Do not use gasoline with more than 10% ethanol (E15, E20, E85, etc.). Use fresh 87+ octane stabilizer-treated unleaded gasoline. Do not use gasoline with more than 10% ethanol (E15, E20, E85, etc.). Pull on Starter Handle to prime. Clean out passageways using fuel additive. Heavy deposits may require further cleaning. Gently tap side of carburetor float chamber with screwdriver handle. Turn START to RUN position. Remove spark plug and pull the start handle several times to air out the chamber. Reinstall spark plug and set START to START position. Replace Fuel Filter.
	<p>IGNITION (SPARK) RELATED:</p> <ol style="list-style-type: none"> Spark plug cap not connected securely. Spark plug electrode wet or dirty. Incorrect spark plug gap. Spark plug cap broken. Circuit breaker tripped. Incorrect spark timing or faulty ignition system. 	<p>IGNITION (SPARK) RELATED:</p> <ol style="list-style-type: none"> Connect spark plug cap properly. Clean spark plug. Correct spark plug gap. Replace spark plug cap. Reset circuit breaker. Check wiring and starter motor if breaker continues to trip. Have qualified technician diagnose/repair ignition system.
	<p>COMPRESSION RELATED:</p> <ol style="list-style-type: none"> Cylinder not lubricated. Problem after long storage periods. Loose or broken spark plug. (Hissing noise will occur when trying to start.) Loose cylinder head or damaged head gasket. (Hissing noise will occur when trying to start.) Engine valves or tappets mis-adjusted or stuck. 	<p>COMPRESSION RELATED:</p> <ol style="list-style-type: none"> Pour tablespoon of oil into spark plug hole. Crank engine a few times and try to start again. Tighten spark plug. If that does not work, replace spark plug. If problem persists, may have head gasket problem, see #3. Tighten head. If that does not remedy problem, replace head gasket. Have qualified technician adjust/repair valves and tappets.



Follow all safety precautions whenever diagnosing or servicing the generator or engine.

Problem	Possible Causes	Probable Solutions
Engine misfires	<ol style="list-style-type: none"> 1. Spark plug cap loose. 2. Incorrect spark plug gap or damaged spark plug. 3. Defective spark plug cap. 4. Old or low quality gasoline. 5. Incorrect compression. 	<ol style="list-style-type: none"> 1. Check wire connections. 2. Re-gap or replace spark plug. 3. Replace spark plug cap. 4. Use only fresh 87+ octane stabilizer-treated unleaded gasoline. Do not use gasoline with more than 10% ethanol (E15, E20, E85, etc.). 5. Diagnose and repair compression. (Use Engine will not start: COMPRESSION RELATED section.)
Engine stops suddenly	<ol style="list-style-type: none"> 1. Fuel tank empty or full of impure or low quality gasoline. 2. Low oil shutdown. 3. Defective fuel tank cap creating vacuum, preventing proper fuel flow. 4. Faulty magneto. 5. Disconnected or improperly connected spark plug cap. 	<ol style="list-style-type: none"> 1. Fill fuel tank with fresh 87+ octane stabilizer-treated unleaded gasoline. Do not use gasoline with more than 10% ethanol (E15, E20, E85, etc.). 2. Fill engine oil to proper level. Check engine oil before EVERY use. 3. Test/replace fuel tank cap. 4. Have qualified technician service magneto. 5. Secure spark plug cap.
Engine stops when under heavy load	<ol style="list-style-type: none"> 1. Dirty air filter 2. Engine running cold. 	<ol style="list-style-type: none"> 1. Clean element. 2. Allow engine to warm up prior to operating equipment.
Engine knocks	<ol style="list-style-type: none"> 1. Old or low quality gasoline. 2. Engine overloaded. 3. Incorrect spark timing, deposit buildup, worn engine, or other mechanical problems. 	<ol style="list-style-type: none"> 1. Fill fuel tank with fresh 87+ octane stabilizer-treated unleaded gasoline. Do not use gasoline with more than 10% ethanol (E15, E20, E85, etc.). 2. Do not exceed equipment's load rating. 3. Have qualified technician diagnose and service engine.
Engine backfires	<ol style="list-style-type: none"> 1. Impure or low quality gasoline. 2. Engine too cold. 3. Intake valve stuck or overheated engine. 4. Incorrect timing. 	<ol style="list-style-type: none"> 1. Fill fuel tank with fresh 87+ octane stabilizer-treated unleaded gasoline. Do not use gasoline with more than 10% ethanol (E15, E20, E85, etc.). 2. Use cold weather fuel and oil additives to prevent backfiring. 3. Have qualified technician diagnose and service engine. 4. Check engine timing.
Attached device doesn't have power	<ol style="list-style-type: none"> 1. Device not plugged in properly. 2. Circuit Breaker tripped. 3. Product needs service. 	<ol style="list-style-type: none"> 1. Turn off and unplug the device, then plug it back in again and turn on. 2. Turn off and unplug device, reset Circuit Breaker, plug in device and turn on. 3. Have product repaired.
Attached device begins to operate abnormally	<ol style="list-style-type: none"> 1. Problem with device. 2. Rated load capacity exceeded. 	<ol style="list-style-type: none"> 1. Immediately unplug device. Have device repaired by a qualified technician, or replace device. 2. Lower the number of items plugged into the generator to stay within the rated capacity, or use a more powerful generator.



Follow all safety precautions whenever diagnosing or servicing the generator or engine.

Limited 90 Day Warranty

Harbor Freight Tools Co. makes every effort to assure that its products meet high quality and durability standards, and warrants to the original purchaser that this product is free from defects in materials and workmanship for the period of 90 days from the date of purchase. This warranty does not apply to damage due directly or indirectly, to misuse, abuse, negligence or accidents, repairs or alterations outside our facilities, criminal activity, improper installation, normal wear and tear, or to lack of maintenance. We shall in no event be liable for death, injuries to persons or property, or for incidental, contingent, special or consequential damages arising from the use of our product. Some states do not allow the exclusion or limitation of incidental or consequential damages, so the above limitation of exclusion may not apply to you. THIS WARRANTY IS EXPRESSLY IN LIEU OF ALL OTHER WARRANTIES, EXPRESS OR IMPLIED, INCLUDING THE WARRANTIES OF MERCHANTABILITY AND FITNESS.

To take advantage of this warranty, the product or part must be returned to us with transportation charges prepaid. Proof of purchase date and an explanation of the complaint must accompany the merchandise.

If our inspection verifies the defect, we will either repair or replace the product at our election or we may elect to refund the purchase price if we cannot readily and quickly provide you with a replacement. We will return repaired products at our expense, but if we determine there is no defect, or that the defect resulted from causes not within the scope of our warranty, then you must bear the cost of returning the product.

This warranty gives you specific legal rights and you may also have other rights which vary from state to state.

Emissions Control System Warranty

United States Emissions Control Defects Warranty Statement

The United States Environmental Protection Agency (herein EPA) and Harbor Freight Tools (herein HFT) are pleased to explain the emissions control system warranty on your 2014-2015 Small Off-Road Engine (herein engine). Within the United States, new off-road, spark-ignition engines certified for model year 2014-2015, must meet similar standards set forth by the EPA. HFT must warrant the emissions control system on your engine for the periods of time described below, provided there has been no abuse, neglect or improper maintenance of your engine.

Your emissions control system may include parts such as the carburetor or fuel-injection system, and the ignition system. Also included may be hoses, belts, connectors and other emissions-related assemblies.

Where a warrantable condition exists, HFT will repair your engine at no cost to you including diagnosis, parts and labor.

Manufacturer's Warranty Coverage

The 2014-2015 engines are warranted for two (2) years. If any emissions-related part on your engine is defective, the part will be repaired or replaced by HFT.

Harbor Freight Tools Emissions Control Defects Warranty Coverage

Engines are warranted for a period of two (2) years relative to emissions control parts defects, subject to the provisions set forth below. If any emissions related part on your engine is defective, the part will be repaired or replaced by HFT.

Owner's Warranty Responsibilities

- As the engine owner, you are responsible for the performance of the required maintenance listed in your Owner's Manual. HFT recommends that you retain all receipts covering maintenance on your engine, but HFT cannot deny warranty solely for the lack of receipts or for your failure to ensure the performance of all scheduled maintenance.
- As the engine owner, you should, however, be aware that HFT may deny you warranty coverage if your engine or a part has failed due to abuse, neglect, improper maintenance, or unapproved modifications.
- You are responsible for shipping your engine to a HFT warranty station as soon as a problem exists. Contact the HFT Customer Service department at the number below to make shipping arrangements. The warranty repairs should be completed in a reasonable amount of time, not to exceed 30 days.

If you have any questions regarding your warranty rights and responsibilities, you should contact the Harbor Freight Tools Customer Service Department at 1-888-866-5797.

Harbor Freight Tools Emissions Control Defects Warranty Provisions

1. Length of Coverage

HFT warrants to a first retail purchaser and each subsequent purchaser that the engine is free from defects in materials and workmanship that cause the failure of warranted parts for a period of two (2) years after the date of delivery to the first retail purchaser.

2. No Charge Repair or Replacement

Repair or replacement of any warranted part will be performed at no charge to the owner if the work is performed through a warranty station authorized by HFT. For emissions warranty service, contact the HFT Customer Service Department at 1-888-866-5797.

3. Consequential Damages Coverage

Coverage under this warranty shall also extend to the failure of any engine components caused by the failure of any warranted part while it is still covered under this warranty.

4. Coverage Exclusions

Warranty claims shall be filed in accordance with the provisions of the HFT warranty policy explained in the box at the top of the previous page. HFT shall not be liable for any loss of use of the engine, for any alternative usage, for any damage to goods, loss of time, or inconvenience. Warranty coverage shall also be excluded for any part which fails, malfunctions, or is damaged due to failure to follow the maintenance and operating instructions set forth in the Owner's Manual including, but not limited to:

- a) Use of parts which are not authorized by HFT
- b) Improper installation, adjustment or repair of the engine or of any warranted part unless performed by an authorized warranty center
- c) Failure to follow recommendations on fuel use contained in the Owner's Manual
- d) Improper or inadequate maintenance of any warranted parts
- e) Repairs performed outside of the authorized warranty service dealers
- f) Alterations by changing, adding to or removing parts from the engine.

5. Service and Maintenance

Component parts which are not scheduled for replacement as required maintenance or are scheduled only for regular inspection to the effect of "repair or replace as necessary" are warranted for the warranty period. Any warranted part which is scheduled for replacement as required maintenance is warranted for the period of time up to the first scheduled replacement point for that part. Any replacement part, provided it is equivalent in durability and performance, may be used in performance of maintenance or repairs. The owner is responsible for commissioning a qualified technician/mechanic to perform all required maintenance, as outlined in the Inspection, Cleaning, and Maintenance section in this manual.

6. Warranted Parts

1) Fuel Metering System

- i) Carburetor and its internal parts.
- ii) Fuel pump (if so equipped).
- iii) Cold start enrichment system.

2) Air Induction System

- i) Intake pipe/manifold.
- ii) Air cleaner.

3) Ignition System

- i) Spark plug.
- ii) Magneto ignition system.

4) Catalyst System (if so equipped)

- i) Exhaust pipe stud.
- ii) Muffler.
- iii) Catalytic converter (if so equipped).

5) Miscellaneous Items Used in Above Systems

- i) Vacuum, temperature and time sensitive valves and switches.
- ii) Hoses, belts, connectors, and assemblies.

PLEASE READ THE FOLLOWING CAREFULLY

THE MANUFACTURER AND/OR DISTRIBUTOR HAS PROVIDED THE PARTS LIST AND ASSEMBLY DIAGRAM IN THIS MANUAL AS A REFERENCE TOOL ONLY. NEITHER THE MANUFACTURER OR DISTRIBUTOR MAKES ANY REPRESENTATION OR WARRANTY OF ANY KIND TO THE BUYER THAT HE OR SHE IS QUALIFIED TO MAKE ANY REPAIRS TO THE PRODUCT, OR THAT HE OR SHE IS QUALIFIED TO REPLACE ANY PARTS OF THE PRODUCT. IN FACT, THE MANUFACTURER AND/OR DISTRIBUTOR EXPRESSLY STATES THAT ALL REPAIRS AND PARTS REPLACEMENTS SHOULD BE UNDERTAKEN BY CERTIFIED AND LICENSED TECHNICIANS, AND NOT BY THE BUYER. THE BUYER ASSUMES ALL RISK AND LIABILITY ARISING OUT OF HIS OR HER REPAIRS TO THE ORIGINAL PRODUCT OR REPLACEMENT PARTS THERETO, OR ARISING OUT OF HIS OR HER INSTALLATION OF REPLACEMENT PARTS THERETO.

Record Product's Serial Number Here: _____

Note: If product has no serial number, record month and year of purchase instead.

Note: Some parts are listed and shown for illustration purposes only, and are not available individually as replacement parts.

Parts List

SAFETY

SETUP

OPERATION

MAINTENANCE

Part	Description	Qty
1	Cylinder Head Cover Bolt	2
2	Cover, Cylinder Head	1
3	Gasket, Cylinder Head Cover	2
4	Plug, Spark	2
5	Bolt, Cylinder Head	8
6	Cylinder Head	1
7	Right Cylinder Head	1
8	Pin	4
9	Gasket, Cylinder Head	4
10	Cross-Band Veneer	2
11	Stud	4
12	Stud	4
13	Cover, Cylinder Head	1
14	Plug , Engine Oil	1
15	Ring, Seal	1
16	Crankcase	1
17	Pin	2
18	Washer, Flat	3
19	Arm, Governor	1
20	Seal, Oil	1
21	Bolt, Drain Plug	2
22	Washer, Flat	2
23	Seal, Oil	1
24	Strainer, Breath Groove	1
25	Piece, Breath	1
26	Gasket, Breath Groove	1
27	Gasket, Breath Groove	1
28	Plate, Breath Groove Cover	1
29	Clamp	1
30	Bolt	2
31	Bolt	2
32	Clamp	2
33	Tube, Breather	1
34	Gasket, Inlet	2
35	Tube, Intake	1
36	Nut	4
37	Pump Asm, Gasoline	1
38	Bolt	3
39	Sleeve, Gasoline Pump Rubber	2
40	Support, Gasoline Pump	1
41	Strainer, Fuel	1
42	Clamp	6
43	Tube, Negative Pressure	1
44	Tube, Negative Pressure	1
45	Clamp	2
46	Tube, Fuel	1
47	Separator, Gas and Oil	1
48	Tube, Fuel	1
49	Mouth, Negative Pressure	1
50	Sensor, Engine Oil	1
51	Bolt	2
52	Bolt	7
53	Bolt	2
54	Cover , Crankcase	1
55	Pin	2
56	Gasket, Crankcase	1
57	Seal, Oil	1
58	Tube, Suction Oil	1
59	Washer	1
60	Bolt	2
61	Bolt	2
62	Pin	2
63	Pump Asm, Oil	1
64	Cover, Oil Pump	1
65	Spring, Pressure Relief Valve	1
66	Ball, Steel	1
67	Strainer, Oil	1
68	Gear Asm, Governor	1

Part	Description	Qty
69	Oil Dipstick	1
70	Gasket, Oil Pump	1
71	Crankshaft Asm.	1
72	Washer, Thrust	1
73	Rod, Connecting	1
74	Piston	2
75	Pin, Piston	2
76	Clip, Piston Pin	4
77	Ring, The First	2
78	Ring, The Second	2
79	Ring Set, Oil	2
80	Nut, Valve Lock	4
81	Nut, Valve Adjusting	4
82	Rocker, Valve	4
83	Bolt, Valve Adjusting	4
84	Lifter, Valve	4
85	Tappet, Valve	4
86	Seat, Valve Spring	4
87	Check Ring	4
88	Clamp, Valve Lock	8
89	Spring, Valve	4
90	Guide, Seal	4
91	Retainer, Valve Spring	2
92	Valve, Exhaust	2
93	Valve, Intake	2
94	Camshaft Asm.	1
95	Washer, Camshaft	1
96	Shield, Shroud	1
97	Screw	3
98	Nut	4
99	Shroud Asm.	1
100	Plate, Fan Shield Decorated	1
101	Handle , Lock	2
102	Shroud 2, Cylinder Body	1
103	Diode	1
104	Shroud, Cylinder Body	1
105	Shield, Lower	1
106	Bolt	13
107	Sensor, Pressure	1
108	Shield, Crankcase Side	1
109	Bolt, Flange Shoulder	1
110	Lug	2
111	Bolt, Flange Shoulder	1
112	Shield	1
113	Shield	1
114	Gasket, Oil Filter Cover	1
115	Oil Filter Block	1
116	Ring, Seal	1
117	Tube, Oil Filter Installation	1
118	Oil Filter	1
119	Washer, Flat	2
120	Adapter, Cooling Pipe	2
121	Clamp	4
122	Pipe, Cooling	1
123	Pipe, Cooling	1
124	Radiator Asm.	1
125	Bolt	2
126	Gasket	1
127	Regulator, Voltage	1
128	Clamp	1
129	Gasket, Carburetor	2
130	Gasket, Carburetor Insulator	1
131	Joint, Intake Tube	1
132	Bolt	2
133	Bolt	1
134	Washer	1
135	Tube, Air Cleaner Connecting	1
136	Bolt	4

Parts List (continued)

Part	Description	Qty
137	Carburetor Asm.	1
138	Clip, Governor Rod	1
139	Line, Solenoid Valve AC	1
140	Cleaner, Air	1
141	Cover, Intake Tube	1
142	Bolt	2
143	Screw	2
144	Collar	1
145	Washer	1
146	Tube, Fuel	1
147	Coil, Ignition	1
148	Coil, Ignition	1
149	Bolt	2
150	Stud	2
151	Stud	2
152	Coil , Charge	1
153	Bolt	6
154	Flywheel Asm.	1
155	Washer	1
156	Bolt, Flywheel	1
157	Impeller	1
158	Tray, Impeller Setting	1
159	Bolt	3
160	Pin	2
161	Motor Asm,Starting	1
162	Bolt	2
163	Protector, Oil	1
164	Bolt	1
165	Control Asm, Throttle	1
166	Bolt	2
167	Spring, Governor	1
168	Spring, Choke Return	1
169	Spring, Governor	1
170	Nut	1
171	Bolt, Governor Support	1
172	Support , Governor	1
173	Rod, Governor	1
174	Spring, Throttle Valve Returning	1
175	Rod, Choke	1
176	Clip, Choke Rod	1
177	Bolt	2
178	Nut	4
179	Gasket, Exhaust Outlet	2
180	Muffler Asm.	1
181	Spark Collector	1
182	Tank, Fuel	1
183	Leveler Asm, Oil	1
184	Screw, Cross Groove Pan	2
185	Valve, One Way	1
186	Tube, Fuel	2
187	Sleeve, Fuel Tank Rubber	4
188	Bush	4
189	Washer, Flat	4
190	Bolt	4
191	Strainer, Fuel	1
192	Chain Clip	1
193	Cap Off The Chain	1
194	Cover, Fuel Tank	1
195	Cock Asm, Fuel	1
196	Clamp	1
197	Bellows	1
198	Clamp	1
199	Frame Asm, Engine	1
200	Power Support Combination	1
201	Bolt	16
202	Nut	16
203	Nut	4
204	Washer, Flat	4
205	Cushion, Engine Frame	4
206	Bolt	8
207	Bolt	4

Part	Description	Qty
208	Lifting Handle	1
209	Screw	1
210	Support, Engine Frame Shock Absorption	2
211	Bolt	8
212	Seat, Engine Frame Shock Absorption	2
213	Bolt	2
214	Regulator, Voltage	1
215	Battery	1
216	Bolt, Battery	2
217	Nut	2
218	Clamp, Battery	1
219	Wire, Anode	1
220	Wire, Cathode	1
221	Clip	2
222	Bolt	2
223	Panel, Control	1
224	Oil Temp Ind	1
225	Protector, Overcurrent	1
226	DC Cigarette Lighter	1
227	Terminal, Grounding	1
228	Socket, Power Supply	1
229	Socket, Power Supply	1
230	Socket, Power Supply	1
231	Socket, Power Supply	2
232	Harness, Control Panel Wiring	1
233	Timer	1
234	Key, Stop Engine Switch	1
235	Switch	1
236	Choke Zip Combination	1
237	Protector, Overcurrent	3
238	Protector, Overcurrent	2
239	Breaker, Double-Pole	1
240	Panel , Control	1
241	Bolt	6
242	Cover, Motor Front End	1
243	Bracket, Motor	1
244	Cover, Rear Motor	1
245	Bolt, Stator	4
246	Bolt, Rotor	1
247	Washer, Flat	1
248	Bolt	8
249	Block, Terminal	1
250	Brush , Carbon	1
251	Band	4
252	Nut	4
253	Bolt	4
254	Nut	2
255	Washer, Flat	4
256	Bolt	2
257	Screw	1
258	Motor Asm.	1
259	Plate, Muffler Insulator	1
260	Bolt	4
261	Frame Cover Hinge	2
262	Nut	8
263	Guard Unit	1
264	Protective Sleeve	1
265	Bar, Handle	1
266	Screw Cross Groove Pan	2
267	Guard Unit 2	2
268	Bolt	8
269	Thermal Baffle	1
270	Tube, Handle	1
271	Tube, Handle	2
272	Seat, Handle Tube Connecting	2
273	Bolt	6
274	Nut	6
275	Wheel, Front	2
276	Nut	4
277	Washer, Flat	2
278	Shaft, Front Wheel	2

SAFETY

SETUP

OPERATION

MAINTENANCE

Assembly Diagram

SAFETY

SETUP

OPERATION

MAINTENANCE

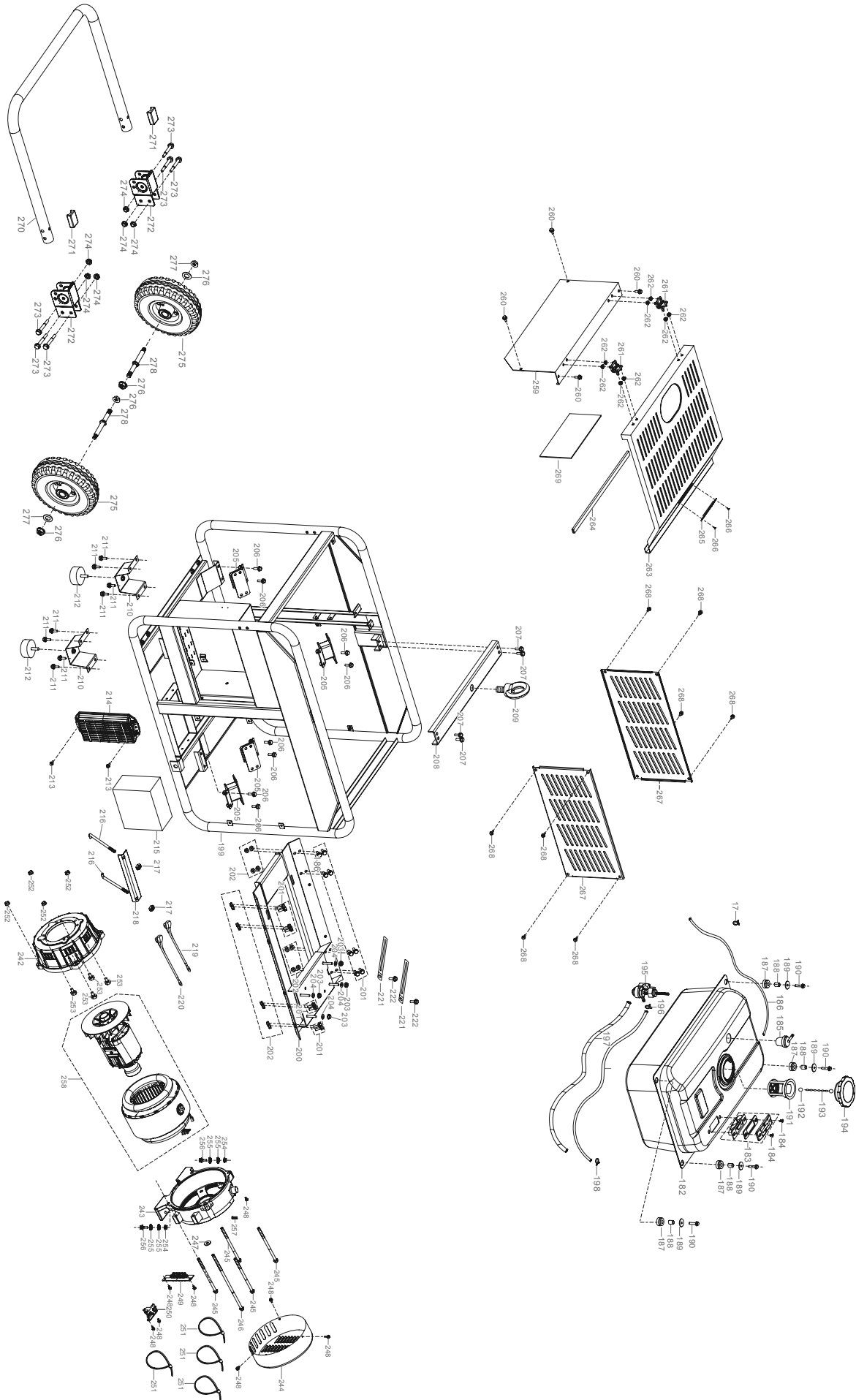

Assembly Diagram (continued)

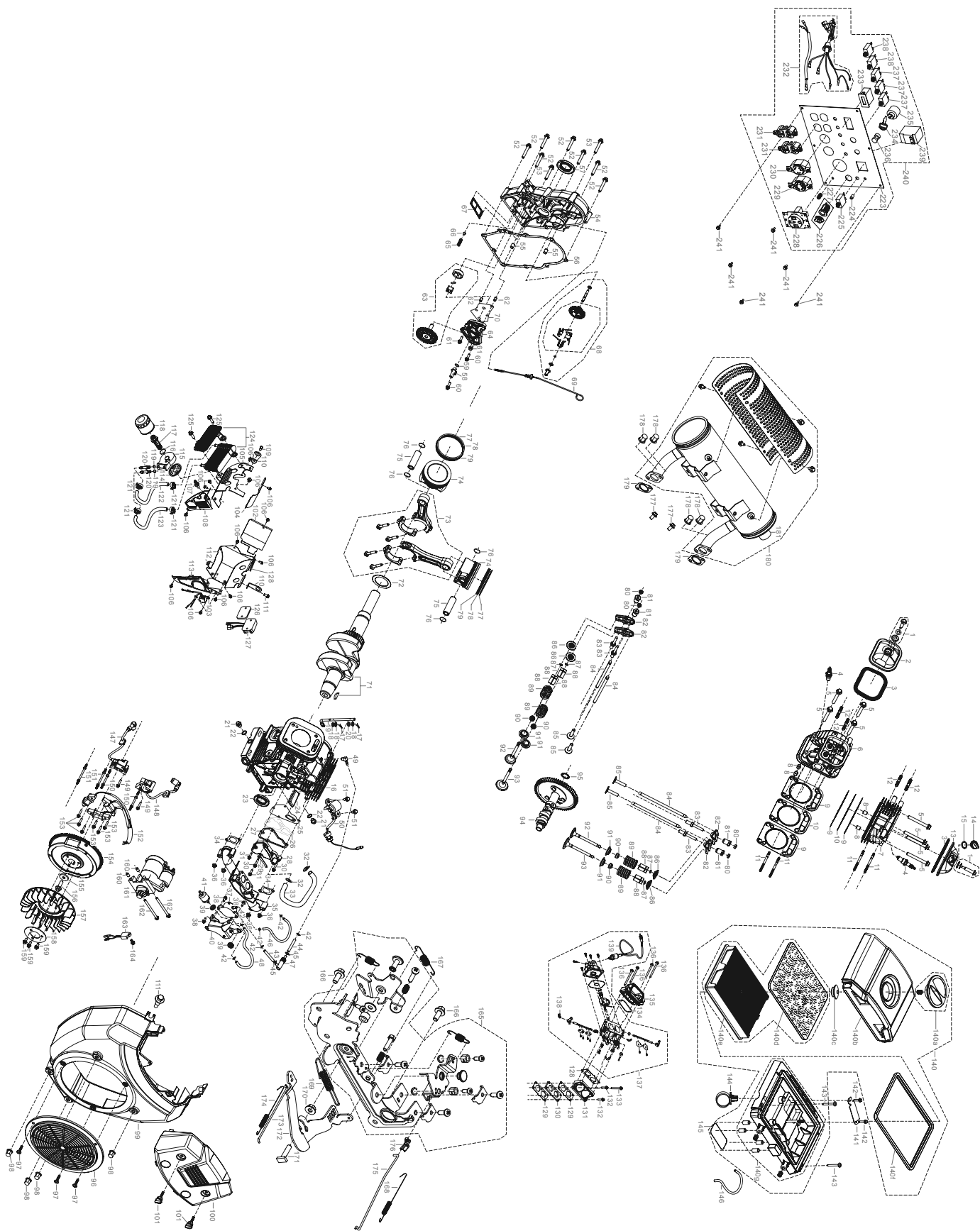

SAFETY

SETUP

OPERATION

MAINTENANCE

PREDATOR™

GENERATORS

3491 Mission Oaks Blvd. • PO Box 6009 • Camarillo, CA 93011 • 1-888-866-5797