

# Owner's Manual & Safety Instructions

**Save This Manual** Keep this manual for the safety warnings and precautions, assembly, operating, inspection, maintenance and cleaning procedures. Write the product's serial number in the back of the manual near the assembly diagram (or month and year of purchase if product has no number). Keep this manual and the receipt in a safe and dry place for future reference.



## 2-1/2 GALLON WET/DRY VACUUM/BLOWER



Visit our website at: <http://www.harborfreight.com>  
Email our technical support at: [tech@harborfreight.com](mailto:tech@harborfreight.com)

**ITEM 61162**

When unpacking, make sure that the product is intact and undamaged. If any parts are missing or broken, please call 1-800-444-3353 as soon as possible.

Copyright© 2013 by Harbor Freight Tools®. All rights reserved.  
No portion of this manual or any artwork contained herein may be reproduced in any shape or form without the express written consent of Harbor Freight Tools. Diagrams within this manual may not be drawn proportionally. Due to continuing improvements, actual product may differ slightly from the product described herein.  
Tools required for assembly and service may not be included.

### **⚠ WARNING**

**Read this material before using this product.  
Failure to do so can result in serious injury.  
SAVE THIS MANUAL.**

# Table of Contents





Safety .....	2	Maintenance .....	9
Specifications .....	4	Parts List and Diagram .....	10
Setup .....	4	Warranty .....	12
Operation.....	6		

SAFETY

SETUP

OPERATION

MAINTENANCE

WARNING SYMBOLS AND DEFINITIONS	
	This is the safety alert symbol. It is used to alert you to potential personal injury hazards. Obey all safety messages that follow this symbol to avoid possible injury or death.
	Indicates a hazardous situation which, if not avoided, will result in death or serious injury.
	Indicates a hazardous situation which, if not avoided, could result in death or serious injury.
	Indicates a hazardous situation which, if not avoided, could result in minor or moderate injury.
	Addresses practices not related to personal injury.

## Instructions Pertaining to a Risk of Fire, Electric Shock, or Injury to Persons

### IMPORTANT SAFETY INSTRUCTIONS

When using an electrical appliance, basic precautions should always be followed, including the following:

#### READ ALL INSTRUCTIONS BEFORE USING THIS APPLIANCE

#### WARNING

To reduce the risk of fire, electric shock, or injury:

- Do not leave appliance when plugged in. Unplug from outlet when not in use and before servicing.
- Do not expose to rain. Store indoors.
- Do not allow to be used as a toy. Close attention is necessary when used by or near children.
- Use only as described in this manual. Use only manufacturer's recommended attachments.
- Do not use with damaged cord or plug. If appliance is not working as it should, has been dropped, damaged, left outdoors, or dropped into water, return it to a service center.
- Do not pull or carry by cord, use cord as a handle, close a door on cord, or pull cord around sharp edges or corners. Do not run appliance over cord. Keep cord away from heated surfaces.
- Do not unplug by pulling on cord. To unplug, grasp the plug, not the cord.
- Do not handle plug or appliance with wet hands.
- Do not put any object into openings. Do not use with any opening blocked; keep free of dust, lint, hair, and anything that may reduce air flow.
- Keep hair, loose clothing, fingers, and all parts of body away from openings and moving parts.
- Turn off all controls before unplugging.
- Use extra care when cleaning on stairs.
- Do not use to pick up flammable or combustible liquids, such as gasoline, or use in areas where they may be present.
- This appliance is provided with double insulation. Use only identical replacement parts. See instructions for Servicing of Double-Insulated Appliances.

15. **Do not pick up anything that is burning or smoking, such as cigarettes, matches, or hot ashes.**
16. **Do not use without dust bag and/or filters in place.**
17. FOR HOUSEHOLD USE ONLY.
18. **Dry your hands and feet before touching plug or switch.**
19. **Do not continue to use the vacuum when the tank is full of liquid.**
20. Stay alert, watch what you are doing and use common sense when operating an appliance. Do not use an appliance while you are tired or under the influence of drugs, alcohol or medication. A moment of inattention while operating appliances may result in serious personal injury.
21. Maintain labels and nameplates on the appliance. These carry important safety information. If unreadable or missing, contact Harbor Freight Tools for a replacement.
22. People with pacemakers should consult their physician(s) before use. Electromagnetic fields in close proximity to heart pacemaker could cause pacemaker interference or pacemaker failure.
23. **WARNING:** Some dust created by power sanding, sawing, grinding, drilling, and other construction activities, contains chemicals known [to the State of California] to cause cancer, birth defects or other reproductive harm. Some examples of these chemicals are:
  - Lead from lead-based paints
  - Crystalline silica from bricks and cement or other masonry products
  - Arsenic and chromium from chemically treated lumber
 Your risk from these exposures varies, depending on how often you do this type of work. To reduce your exposure to these chemicals: work in a well ventilated area, and work with approved safety equipment, such as those dust masks that are specially designed to filter out microscopic particles. (California Health & Safety Code § 25249.5, *et seq.*)
24. **WARNING:** Handling the cord on this product will expose you to lead, a chemical known to the State of California to cause cancer, and birth defects or other reproductive harm. Wash hands after handling. (California Health & Safety Code § 25249.5, *et seq.*)
25. The warnings, precautions, and instructions discussed in this instruction manual cannot cover all possible conditions and situations that may occur. It must be understood by the operator that common sense and caution are factors which cannot be built into this product, but must be supplied by the operator.



## SAVE THESE INSTRUCTIONS

### Servicing of Double-Insulated Appliances

A double-insulated appliance is marked with one or more of the following:  
 The words "DOUBLE INSULATION" or "DOUBLE INSULATED" or  
 the double insulation symbol (square within a square): 

In a double-insulated appliance, two systems of insulation are provided instead of grounding. No grounding means is provided on a double-insulated appliance, nor should a means for grounding be added to the appliance. Servicing a double-insulated appliance requires extreme care and knowledge of the system, and should be done only by qualified service personnel. Replacement parts for a double-insulated appliance must be identical to the parts they replace.

### Polarization Instructions

To reduce the risk of electric shock, this appliance has a polarized plug (one blade is wider than the other). This plug will fit in a polarized outlet only one way. If the plug does not fit fully in the outlet, reverse the plug. If it still does not fit, contact a qualified electrician to install the proper outlet. Do not change the plug in any way.

## Specifications

Electrical Rating	120V~ / 60Hz / 5A
Tank Capacity	2-1/2 gallons (dry), 1-1/4 gallons (wet)
Hose	Ø1-1/4"x4'
Power Cord	8'



## Setup - Before Use:



Read the **ENTIRE IMPORTANT SAFETY INFORMATION** section at the beginning of this manual including all text under subheadings therein before set up or use of this product.

### **WARNING**

**TO PREVENT SERIOUS INJURY FROM ACCIDENTAL OPERATION:**

Turn the **Power Switch** of the appliance off and unplug the appliance from its electrical outlet before performing any procedure in this section.

**Note:** For additional information regarding the parts listed in the following pages, refer to the Assembly Diagram near the end of this manual.

## Assembly

1. Remove Power Head from Tank by lifting the latch on each side of appliance and pulling Power Head up.
2. Remove any stored parts from the Tank.

3. Replace the Power Head into Tank and secure latches.

**Note:** The Vacuum comes with the Cloth Filter installed. Do not use the cloth filter for wet vacuuming.



# Functions

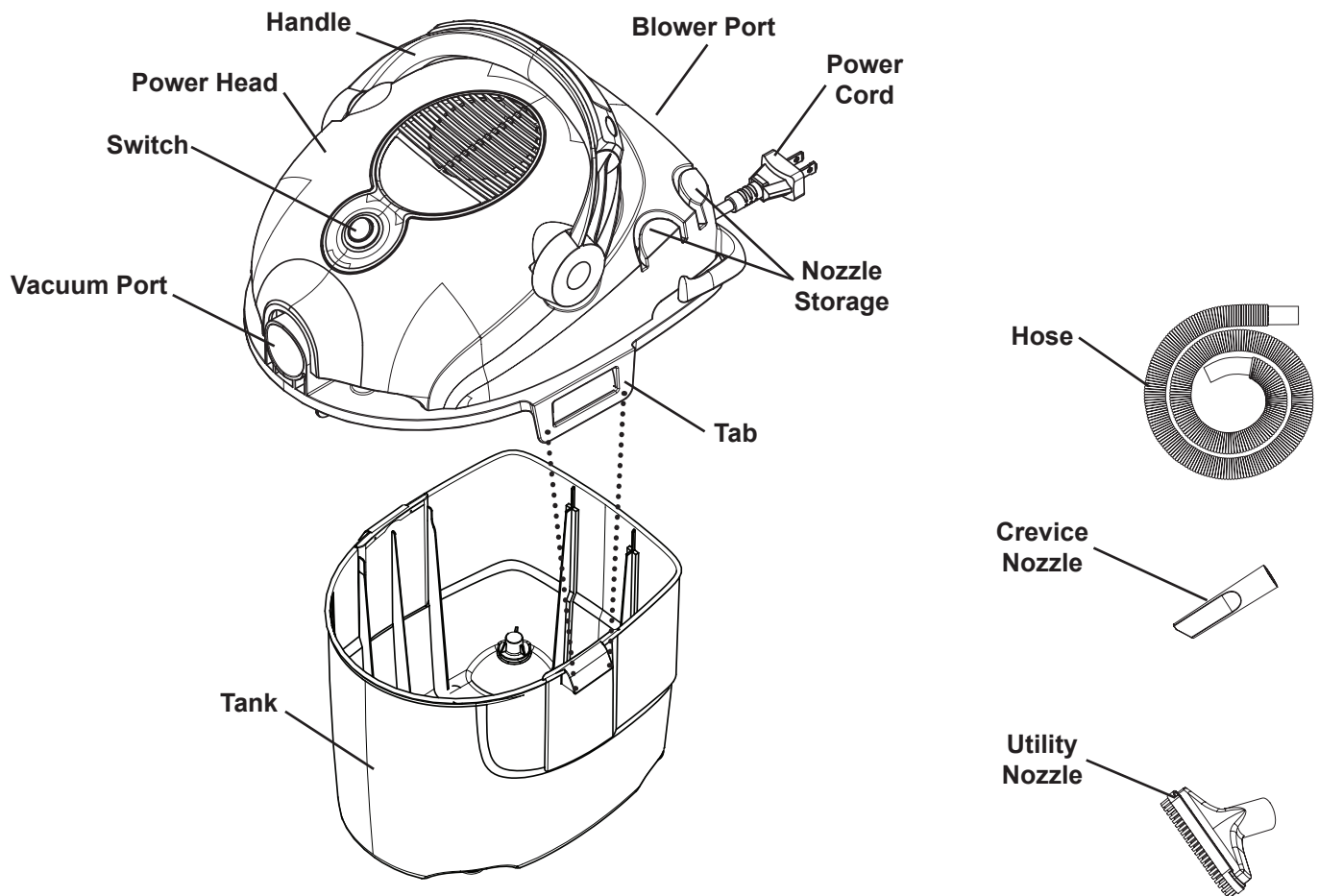

SAFETY

SETUP

OPERATION

MAINTENANCE



## Operating Instructions



Read the **ENTIRE IMPORTANT SAFETY INFORMATION** section at the beginning of this manual including all text under subheadings therein before set up or use of this product.

## Vacuum Operation

### ⚠️ WARNING

**TO PREVENT SERIOUS INJURY FROM ACCIDENTAL OPERATION:**

Turn the Switch off and unplug the power cord from its electrical outlet before removing the Power Head.

1. Pull out on the tabs on the sides of the Power Head and pull up on it to remove it.
2. For dry vacuuming:  
Install Cloth Filter completely onto the Filter Cage.
3. For wet vacuuming:  
Install Foam Filter completely onto the Filter Cage.

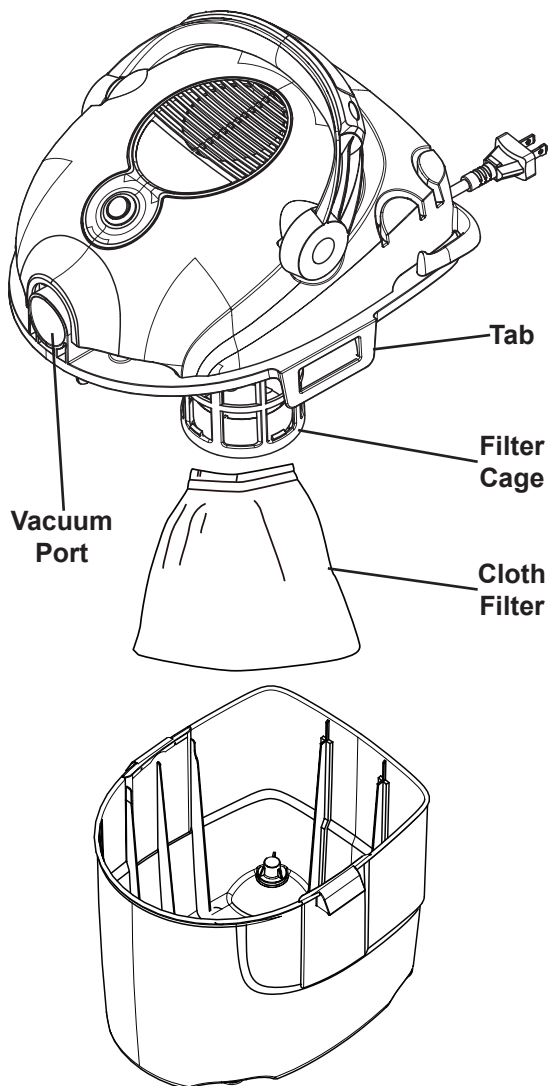

Figure A: Dry Vacuum Setup

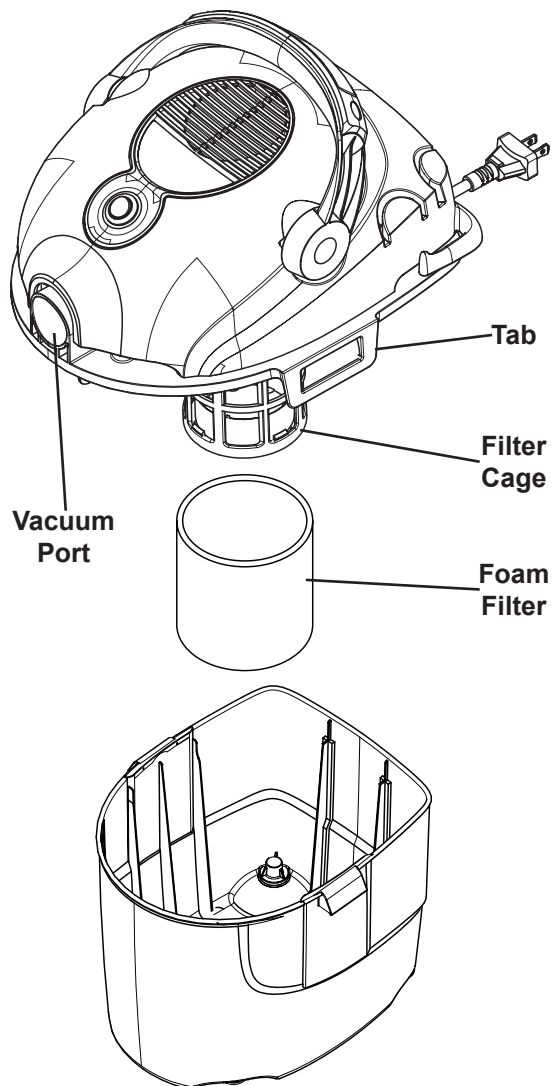

Figure B: Wet Vacuum Setup

SAFETY

SETUP

OPERATION

MAINTENANCE

4. Reassemble the Power Head to the Tank, making sure the tabs lock into place.
5. Insert the larger end of the Hose securely into the Vacuum Port.
6. If desired, slide a Nozzle onto the Hose.

**Table A: RECOMMENDED MINIMUM WIRE GAUGE FOR EXTENSION CORDS (120 VOLT)**

NAMEPLATE AMPERES (at full load)	EXTENSION CORD LENGTH			
	25'	50'	100'	150'
0 – 6	18	16	16	14
6.1 – 10	18	16	14	12
10.1 – 12	16	16	14	12
12.1 – 16	14	12	<b>Do not use.</b>	

7. **USE PROPER EXTENSION CORD.**  
Make sure your extension cord is in good condition. When using an extension cord, be sure to use one heavy enough to carry the current your product will draw. An undersized cord will cause a drop in line voltage resulting in loss of power and overheating. Table A shows the correct size to use depending on cord length and nameplate ampere rating. If in doubt, use the next heavier gauge. The smaller the gauge number, the heavier the cord.
8. Make sure that the Switch is in its off position. Plug the Power Cord into the power outlet.

9. Hold the loose Hose end securely. Turn the switch on to operate the Vacuum.

10. **WHEN WET VACUUMING:**

**IMPORTANT!** Leave a gap at the tip of the nozzle opening to allow air inflow. Do not immerse the nozzle completely in liquid.

**When the Motor sound becomes higher in pitch, the Tank is full and the float is closing off the motor intake.**

**IMMEDIATELY:**

- a. **DRY YOUR HANDS AND FEET,**
- b. turn the Vacuum off,
- c. unplug the Power Cord,
- d. and empty the Tank.

**WARNING! TO PREVENT SERIOUS INJURY FROM ELECTRIC SHOCK:**

**Dry your hands and feet before touching plug or switch.**

**Do not continue to use the vacuum when the tank is full of liquid.**

11. To prevent accidents, **DRY YOUR HANDS AND FEET,** turn off the appliance and unplug it after use. Empty and clean Tank, dry Tank, clean Filter (see **Cleaning Filters** on page 9), then store the appliance indoors out of children's reach.



# Blower Operation

SAFETY

SETUP

OPERATION

MAINTENANCE

## **⚠ WARNING**

**TO PREVENT SERIOUS INJURY FROM ACCIDENTAL OPERATION:**

**Turn the Switch off and unplug the power cord from its electrical outlet before removing the Power Head.**

1. Pull out on the tabs on the sides of the Power Head and pull up on it to remove it.
2. Clean the Tank out before using the appliance as a Blower. **CAUTION! Any material left in the Tank may be blown out, causing injury.**
3. Reassemble the Power Head to the Tank, making sure the tabs lock into place.
4. Remove the Hose from the Vacuum Port. Locate the Blower Port opening at the rear of the Power Head. Insert larger end of the Hose into the Blower Port.
5. **USE PROPER EXTENSION CORD.** Make sure your extension cord is in good condition. When using an extension cord, be sure to use one heavy enough to carry the current your product will draw. An undersized cord will cause a drop in line voltage resulting in loss of power and overheating. Table B shows the correct size to use depending on cord length and nameplate ampere rating. If in doubt, use the next heavier gauge. The smaller the gauge number, the heavier the cord.
6. **CAUTION! Wear ANSI-approved safety goggles before use.**
7. Make sure that the Switch is in its off position. Plug the Power Cord into the power outlet.
8. Hold the loose Hose end securely. Turn the switch on to operate the Blower.

NAMEPLATE AMPERES (at full load)	EXTENSION CORD LENGTH			
	25'	50'	100'	150'
0 – 6	18	16	16	14
6.1 – 10	18	16	14	12
10.1 – 12	16	16	14	12
12.1 – 16	14	12	<b>Do not use.</b>	

9. To prevent accidents, turn off the appliance and disconnect its power supply after use. Clean, then store the appliance indoors out of children's reach.



## User-maintenance and Storage



Procedures not specifically explained in this manual must be performed only by a qualified technician.

### **⚠️ WARNING**

**TO PREVENT SERIOUS INJURY FROM ACCIDENTAL OPERATION:**

Turn the Power Switch of the appliance off and unplug the appliance from its electrical outlet before performing any procedure in this section.

**TO PREVENT SERIOUS INJURY FROM APPLIANCE FAILURE:**

Do not use damaged equipment. If abnormal noise or vibration occurs, have the problem corrected before further use.

## Cleaning, Maintenance, and Lubrication

- BEFORE EACH USE**, inspect the general condition of the appliance. Check for:
  - loose hardware,
  - misalignment or binding of moving parts,
  - cracked or broken parts,
  - damaged electrical wiring, and
  - any other condition that may affect its safe operation.
- AFTER USE**, wipe external surfaces of the appliance with clean cloth. Store in an indoor dry area out of reach of children.
- All parts are permanently lubricated. Do not use additional lubrication.
- ⚠️ WARNING!** If the supply cord of this appliance is damaged, it must be replaced only by a qualified service technician.

### Cleaning Filters

To ensure proper operation, clean the Filters regularly. Torn Filters should be replaced:

#### CLOTH FILTER:

- Gently tap or brush dirt off outdoors.
- Wash Cloth Filter using mild soap and water.
- Rinse all soap and dust out thoroughly.
- Allow the Cloth Filter to dry for at least one day before reinstalling.**



**WARNING!** Installing a wet Filter will increase the risk of electric shock and may damage the vacuum.

- Reinstall the Filter. Make sure it covers the Filter Cage completely.

#### FOAM FILTER:

**NOTICE:** Do not wring the Foam Filter. Wringing the Foam Filter will tear its internal structure and ruin it.

- Gently wash Foam Filter using mild soap and water.
- Rinse all soap and dust out thoroughly.
- Allow the Foam Filter to dry for at least one day before reinstalling.**



**WARNING!** Installing a wet Filter will increase the risk of electric shock and may damage the vacuum.

- Reinstall the Filter. Make sure it covers the Filter Cage completely.

# PLEASE READ THE FOLLOWING CAREFULLY

SAFETY

THE MANUFACTURER AND/OR DISTRIBUTOR HAS PROVIDED THE PARTS LIST AND ASSEMBLY DIAGRAM IN THIS MANUAL AS A REFERENCE TOOL ONLY. NEITHER THE MANUFACTURER OR DISTRIBUTOR MAKES ANY REPRESENTATION OR WARRANTY OF ANY KIND TO THE BUYER THAT HE OR SHE IS QUALIFIED TO MAKE ANY REPAIRS TO THE PRODUCT, OR THAT HE OR SHE IS QUALIFIED TO REPLACE ANY PARTS OF THE PRODUCT. IN FACT, THE MANUFACTURER AND/OR DISTRIBUTOR EXPRESSLY STATES THAT ALL REPAIRS AND PARTS REPLACEMENTS SHOULD BE UNDERTAKEN BY CERTIFIED AND LICENSED TECHNICIANS, AND NOT BY THE BUYER. THE BUYER ASSUMES ALL RISK AND LIABILITY ARISING OUT OF HIS OR HER REPAIRS TO THE ORIGINAL PRODUCT OR REPLACEMENT PARTS THERETO, OR ARISING OUT OF HIS OR HER INSTALLATION OF REPLACEMENT PARTS THERETO.

SETUP

## Parts List and Diagram

### Parts List

Part	Description	Qty
1	Handle	1
2	Power Head	1
3	Filter Cage Cover	1
4	Float	1
5	Tank	1

Part	Description	Qty
6	Crevice Nozzle	1
7	Utility Nozzle	1
8	Hose	1
9	Foam Filter	1
10	Cloth Filter	1

OPERATION

Record Product's Serial Number Here: \_\_\_\_\_

**Note:** If product has no serial number, record month and year of purchase instead.

**Note:** Some parts are listed and shown for illustration purposes only, and are not available individually as replacement parts.

MAINTENANCE



# Assembly Diagram

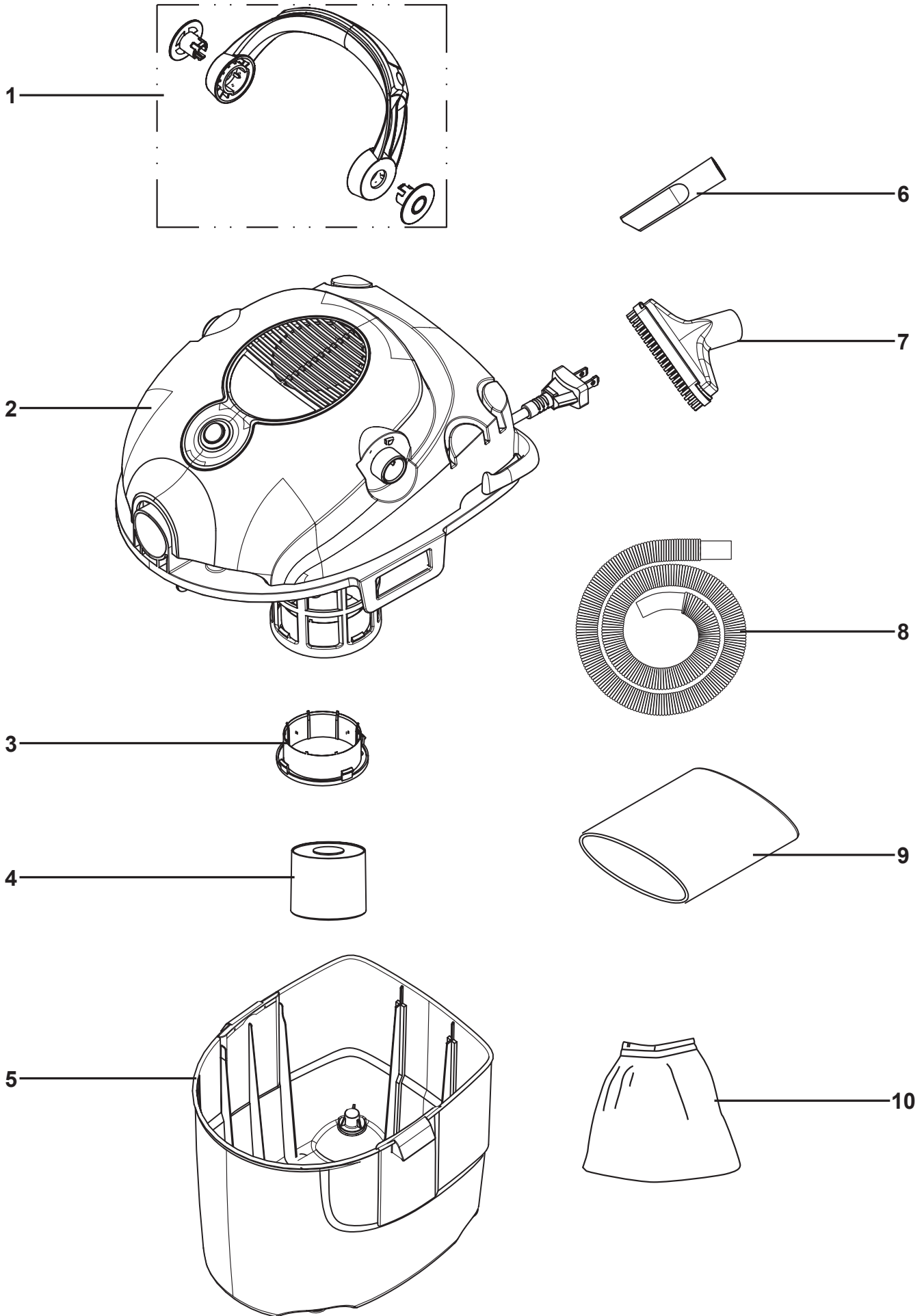

SAFETY

SETUP

OPERATION

MAINTENANCE

## Limited 90 Day Warranty

Harbor Freight Tools Co. makes every effort to assure that its products meet high quality and durability standards, and warrants to the original purchaser that this product is free from defects in materials and workmanship for the period of 90 days from the date of purchase. This warranty does not apply to damage due directly or indirectly, to misuse, abuse, negligence or accidents, repairs or alterations outside our facilities, criminal activity, improper installation, normal wear and tear, or to lack of maintenance. We shall in no event be liable for death, injuries to persons or property, or for incidental, contingent, special or consequential damages arising from the use of our product. Some states do not allow the exclusion or limitation of incidental or consequential damages, so the above limitation of exclusion may not apply to you. THIS WARRANTY IS EXPRESSLY IN LIEU OF ALL OTHER WARRANTIES, EXPRESS OR IMPLIED, INCLUDING THE WARRANTIES OF MERCHANTABILITY AND FITNESS.

To take advantage of this warranty, the product or part must be returned to us with transportation charges prepaid. Proof of purchase date and an explanation of the complaint must accompany the merchandise. If our inspection verifies the defect, we will either repair or replace the product at our election or we may elect to refund the purchase price if we cannot readily and quickly provide you with a replacement. We will return repaired products at our expense, but if we determine there is no defect, or that the defect resulted from causes not within the scope of our warranty, then you must bear the cost of returning the product.

This warranty gives you specific legal rights and you may also have other rights which vary from state to state.

