

Owner's Manual & Safety Instructions

Save This Manual Keep this manual for the safety warnings and precautions, assembly, operating, inspection, maintenance and cleaning procedures. Write the product's serial number in the back of the manual near the assembly diagram (or month and year of purchase if product has no number). Keep this manual and the receipt in a safe and dry place for future reference.

ITEM 61602

HaulMaster[®]

35" STEEL TRAILER TONGUE BOX



Visit our website at: <http://www.harborfreight.com>
Email our technical support at: tech@harborfreight.com

When unpacking, make sure that the product is intact and undamaged. If any parts are missing or broken, please call 1-800-444-3353 as soon as possible.

Copyright© 2013 by Harbor Freight Tools®. All rights reserved.
No portion of this manual or any artwork contained herein may be reproduced in any shape or form without the express written consent of Harbor Freight Tools. Diagrams within this manual may not be drawn proportionally. Due to continuing improvements, actual product may differ slightly from the product described herein.
Tools required for assembly and service may not be included.

⚠ WARNING

**Read this material before using this product.
Failure to do so can result in serious injury.
SAVE THIS MANUAL.**

Specifications

Storage capacity	2.31 cu. ft.
Inside dimensions	11 in. L x 27-1/2 in. - 34-1/2 in. W x 11-1/2 in. H
Overall dimensions	12 in. L x 35 in. W x 12-1/8 in. H

IMPORTANT SAFETY INFORMATION

Installation Precautions

1. Install only according to these instructions. Improper assembly can create hazards.
2. Wear ANSI-approved safety goggles and heavy-duty work gloves during installation.
3. Keep installation area clean and well lit.
4. Keep bystanders out of the area during installation.
5. Do not install when tired or when under the influence of alcohol, drugs or medication.
6. Product capabilities apply to properly and completely installed product only.

Use Precautions

1. This product is not a toy. Do not allow children to play with or near this item.
2. Use as intended only.
3. Inspect before every use; do not use if parts are loose or damaged. Before use, check that the "U" bolts, support plates, and nuts are tightened securely.
4. Lock trailer box before transporting.
5. Follow Department of Transportation (DOT) regulations.
6. Maintain product labels and nameplates. These carry important safety information. If unreadable or missing, contact Harbor Freight Tools for a replacement.
7. **WARNING:** The brass components of this product contain lead, a chemical known to the State of California to cause birth defects (or other reproductive harm). (California Health & Safety code § 25249.5, et seq.)

Mounting Instructions



Read the **ENTIRE IMPORTANT SAFETY INFORMATION** section at the beginning of this document including all text under subheadings therein before set up or use of this product.

1. Place the Box on the trailer tongue (not supplied) with the wider part near the trailer.
 2. Insert a "U" bolt through one of the Plates. Insert the legs of the "U" Bolt through the holes in the bottom of the Box to straddle the trailer tongue bar. Repeat with the other "U" Bolt.
 3. Fit a Plate over the legs of a "U" Bolt and hold in place with two Nuts. Repeat for other side.
 4. Tighten all 4 Nuts, firmly clamping the Box onto the trailer tongue.
- NOTE:** Two keys are provided. Keep these in a safe place when not in use.
5. Occasionally apply a lock lubricant to the lock to keep it in good condition.



Parts List and Diagram

Part	Description	Qty
1	Box	1
2	Lid	1
3	Hinge	2
4	Gas Lid Support	1
5	Lock	1

Part	Description	Qty
6	"U" Bolt Set ("U" Bolt, 2 Plates, 2 Nuts each)	2
7	Gasket	1
8	Key (not shown)	2

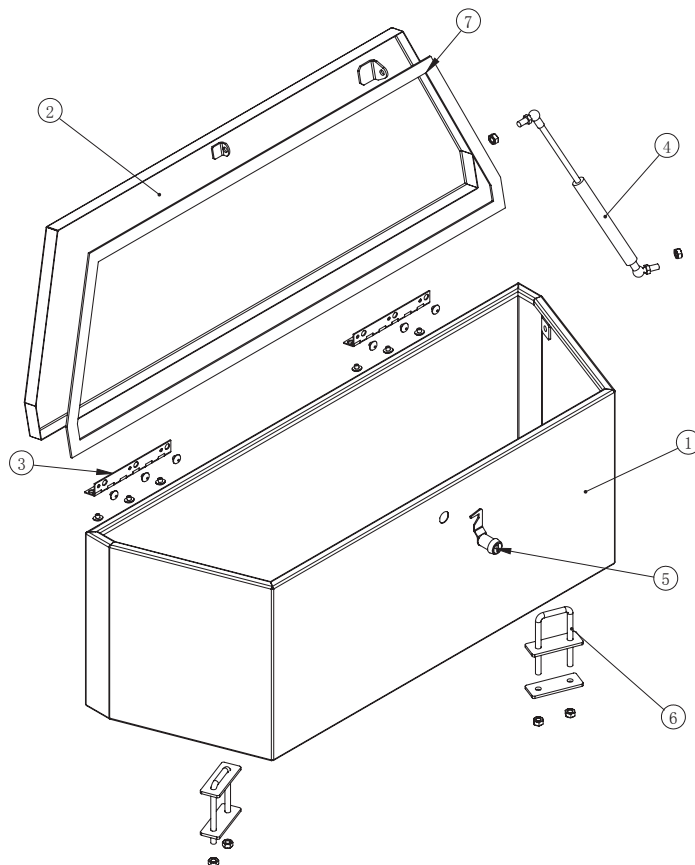

Record Serial Number Here:

Note: If product has no serial number, record month and year of purchase instead.

Note: Some parts are listed and shown for illustration purposes only, and are not available individually as replacement parts.

PLEASE READ THE FOLLOWING CAREFULLY

THE MANUFACTURER AND/OR DISTRIBUTOR HAS PROVIDED THE PARTS LIST AND ASSEMBLY DIAGRAM IN THIS DOCUMENT AS A REFERENCE TOOL ONLY. NEITHER THE MANUFACTURER OR DISTRIBUTOR MAKES ANY REPRESENTATION OR WARRANTY OF ANY KIND TO THE BUYER THAT HE OR SHE IS QUALIFIED TO MAKE ANY REPAIRS TO THE PRODUCT, OR THAT HE OR SHE IS QUALIFIED TO REPLACE ANY PARTS OF THE PRODUCT. IN FACT, THE MANUFACTURER AND/OR DISTRIBUTOR EXPRESSLY STATES THAT ALL REPAIRS AND PARTS REPLACEMENTS SHOULD BE UNDERTAKEN BY CERTIFIED AND LICENSED TECHNICIANS, AND NOT BY THE BUYER. THE BUYER ASSUMES ALL RISK AND LIABILITY ARISING OUT OF HIS OR HER REPAIRS TO THE ORIGINAL PRODUCT OR REPLACEMENT PARTS THERETO, OR ARISING OUT OF HIS OR HER INSTALLATION OF REPLACEMENT PARTS THERETO.

Limited 90 Day Warranty

Harbor Freight Tools Co. makes every effort to assure that its products meet high quality and durability standards, and warrants to the original purchaser that this product is free from defects in materials and workmanship for the period of 90 days from the date of purchase. This warranty does not apply to damage due directly or indirectly, to misuse, abuse, negligence or accidents, repairs or alterations outside our facilities, criminal activity, improper installation, normal wear and tear, or to lack of maintenance. We shall in no event be liable for death, injuries to persons or property, or for incidental, contingent, special or consequential damages arising from the use of our product. Some states do not allow the exclusion or limitation of incidental or consequential damages, so the above limitation of exclusion may not apply to you. THIS WARRANTY IS EXPRESSLY IN LIEU OF ALL OTHER WARRANTIES, EXPRESS OR IMPLIED, INCLUDING THE WARRANTIES OF MERCHANTABILITY AND FITNESS.

To take advantage of this warranty, the product or part must be returned to us with transportation charges prepaid. Proof of purchase date and an explanation of the complaint must accompany the merchandise. If our inspection verifies the defect, we will either repair or replace the product at our election or we may elect to refund the purchase price if we cannot readily and quickly provide you with a replacement. We will return repaired products at our expense, but if we determine there is no defect, or that the defect resulted from causes not within the scope of our warranty, then you must bear the cost of returning the product.

This warranty gives you specific legal rights and you may also have other rights which vary from state to state.

