

Owner's Manual & Safety Instructions

Save This Manual Keep this manual for the safety warnings and precautions, assembly, operating, inspection, maintenance and cleaning procedures. Write the product's serial number in the back of the manual near the assembly diagram (or month and year of purchase if product has no number). Keep this manual and the receipt in a safe and dry place for future reference.



3-1/2 Cubic Ft. CEMENT MIXER



NOTICE
FOR CEMENT AND
MORTAR ONLY.
Do not use with Epoxy
2-part resin mix.

REV 14a

Visit our website at: <http://www.harborfreight.com>
Email our technical support at: productsupport@harborfreight.com **ITEM 61932**

When unpacking, make sure that the product is intact and undamaged. If any parts are missing or broken, please call 1-888-866-5797 as soon as possible.

Copyright© 2013 by Harbor Freight Tools®. All rights reserved.
No portion of this manual or any artwork contained herein may be reproduced in any shape or form without the express written consent of Harbor Freight Tools. Diagrams within this manual may not be drawn proportionally. Due to continuing improvements, actual product may differ slightly from the product described herein.
Tools required for assembly and service may not be included.

⚠ WARNING

**Read this material before using this product.
Failure to do so can result in serious injury.
SAVE THIS MANUAL.**

NOTICE

FOR CEMENT AND MORTAR ONLY.
Do not use with Epoxy 2-part resin mix.

Table of Contents

Safety	3	Maintenance	12
Specifications	6	Parts List and Diagram	14
Setup	7	Warranty	16
Operation.....	10		





SAFETY

SETUP

OPERATION

MAINTENANCE

WARNING SYMBOLS AND DEFINITIONS

	This is the safety alert symbol. It is used to alert you to potential personal injury hazards. Obey all safety messages that follow this symbol to avoid possible injury or death.
	Indicates a hazardous situation which, if not avoided, will result in death or serious injury.
	Indicates a hazardous situation which, if not avoided, could result in death or serious injury.
	Indicates a hazardous situation which, if not avoided, could result in minor or moderate injury.
	Addresses practices not related to personal injury.



NOTICE

FOR CEMENT AND MORTAR ONLY.
Do not use with Epoxy 2-part resin mix.

IMPORTANT SAFETY INFORMATION



WARNING Read all safety warnings and instructions. Failure to follow the warnings and instructions may result in electric shock, fire and/or serious injury.

Save all warnings and instructions for future reference.

Assembly Precautions

1. Assemble only according to these instructions. Improper assembly can create hazards.
2. Wear ANSI-approved safety goggles and heavy-duty work gloves during assembly.
3. Keep assembly area clean and well lit.
4. Keep bystanders out of the area during assembly.
5. Do not assemble when tired or when under the influence of alcohol, drugs or medication.
6. Weight capacity and other product capabilities apply to properly and completely assembled product only.

Use Precautions

1. This product is not a toy. Do not allow children to play with or near this item.
2. Use as intended only.
3. Inspect before every use; do not use if parts are loose or damaged.
4. Do not exceed listed weight capacity. **Be aware of dynamic loading!** Sudden load movement may briefly create excess load causing product failure.
5. **DO NOT OVERLOAD MIXER.** An overload can damage equipment.
6. **DO NOT MOVE MIXER DURING OPERATION.** The Mixer can tip over or motor could be damaged.
7. **KEEP SAFE CLEARANCE AROUND MIXER.** Keep all persons (except operator) at least six feet from Mixer during operation.
8. **DON'T USE IN DANGEROUS ENVIRONMENT.** Don't use power tools in damp or wet locations, or expose them to rain. Keep work area well lighted.
9. **KEEP CHILDREN AWAY.** All visitors should be kept safe distance from work area.
10. **MAKE WORKSHOP KID PROOF** with padlocks, master switches, or by removing starter keys.
11. **DON'T FORCE TOOL.** It will do the job better and safer at the rate for which it was designed.
12. **USE RIGHT TOOL.** Don't force tool or attachment to do a job for which it was not designed.
13. **USE PROPER EXTENSION CORD.** Make sure your extension cord is in good condition. When using an extension cord, be sure to use one heavy enough to carry the current your product will draw. An undersized cord will cause a drop in line voltage resulting in loss of power and overheating. Table A shows the correct size to use depending on cord length and nameplate ampere rating. If in doubt, use the next heavier gauge. The smaller the gauge number, the heavier the cord.
14. **WEAR PROPER APPAREL.** Do not wear loose clothing, gloves, neckties, rings, bracelets, or other jewelry which may get caught in moving parts. Nonslip footwear is recommended. Wear protective hair covering to contain long hair.
15. **SECURE WORK.** Use clamps or a vise to hold work when practical. It's safer than using your hand and it frees both hands to operate tool.
16. **DON'T OVERREACH.** Keep proper footing and balance at all times.
17. **MAINTAIN TOOLS WITH CARE.** Keep tools sharp and clean for best and safest performance. Follow instructions for lubricating and changing accessories.
18. **DISCONNECT TOOLS** before servicing; when changing accessories, such as blades, bits, cutters, and the like.
19. **REDUCE THE RISK OF UNINTENTIONAL STARTING.** Make sure switch is in off position before plugging in.
20. **NEVER STAND ON TOOL.** Serious injury could occur if the tool is tipped or if the cutting tool is unintentionally contacted.
21. **NEVER LEAVE TOOL RUNNING UNATTENDED. TURN POWER OFF.** Don't leave tool until it comes to a complete stop.
22. Maintain product labels and nameplates. These carry important safety information. If unreadable or missing, contact Harbor Freight Tools for a replacement.

NOTICE

FOR CEMENT AND MORTAR ONLY.
Do not use with Epoxy 2-part resin mix.

Grounding

⚠ WARNING



TO PREVENT ELECTRIC SHOCK AND DEATH FROM INCORRECT GROUNDING WIRE CONNECTION:

Check with a qualified electrician if you are in doubt as to whether the outlet is properly grounded. Do not modify the power cord plug provided with the tool. Never remove the grounding prong from the plug. Do not use the tool if the power cord or plug is damaged. If damaged, have it repaired by a service facility before use. If the plug will not fit the outlet, have a proper outlet installed by a qualified electrician.

Grounded Tools: Tools with Three Prong Plugs

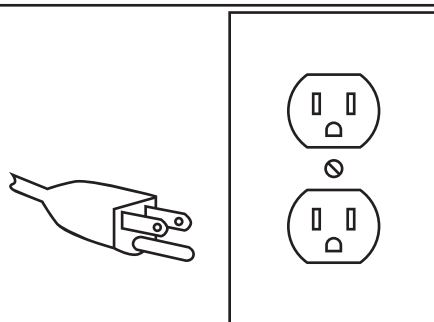

3-Prong Plug and Outlet

1. Tools marked with “Grounding Required” have a three wire cord and three prong grounding plug. The plug must be connected to a properly grounded outlet. If the tool should electrically malfunction or break down, grounding provides a low resistance path to carry electricity away from the user, reducing the risk of electric shock. **(See 3-Prong Plug and Outlet.)**

2. The grounding prong in the plug is connected through the green wire inside the cord to the grounding system in the tool. The green wire in the cord must be the only wire connected to the tool’s grounding system and must never be attached to an electrically “live” terminal. **(See 3-Prong Plug and Outlet.)**

3. The tool must be plugged into an appropriate outlet, properly installed and grounded in accordance with all codes and ordinances. The plug and outlet should look like those in the preceding illustration. **(See 3-Prong Plug and Outlet.)**

Extension Cords

1. **Grounded** tools require a three wire extension cord. **Double Insulated** tools can use either a two or three wire extension cord.
2. As the distance from the supply outlet increases, you must use a heavier gauge extension cord. Using extension cords with inadequately sized wire causes a serious drop in voltage, resulting in loss of power and possible tool damage. **(See Table A.)**
3. The smaller the gauge number of the wire, the greater the capacity of the cord. For example, a 14 gauge cord can carry a higher current than a 16 gauge cord. **(See Table A.)**
4. When using more than one extension cord to make up the total length, make sure each cord contains at least the minimum wire size required. **(See Table A.)**
5. If you are using one extension cord for more than one tool, add the nameplate amperes and use the sum to determine the required minimum cord size. **(See Table A.)**
6. If you are using an extension cord outdoors, make sure it is marked with the suffix “W-A” (“W” in Canada) to indicate it is acceptable for outdoor use.
7. Make sure the extension cord is properly wired and in good electrical condition. Always replace a damaged extension cord or have it repaired by a qualified electrician before using it.
8. Protect the extension cords from sharp objects, excessive heat, and damp or wet areas.

NOTICE

FOR CEMENT AND MORTAR ONLY.
Do not use with Epoxy 2-part resin mix.

TABLE A: RECOMMENDED MINIMUM WIRE GAUGE FOR EXTENSION CORDS* (120/240 VOLT)

NAMEPLATE AMPERES (at full load)	EXTENSION CORD LENGTH				
	25'	50'	75'	100'	150'
0 – 2.0	18	18	18	18	16
2.1 – 3.4	18	18	18	16	14
3.5 – 5.0	18	18	16	14	12
5.1 – 7.0	18	16	14	12	12
7.1 – 12.0	18	14	12	10	-
12.1 – 16.0	14	12	10	-	-
16.1 – 20.0	12	10	-	-	-

* Based on limiting the line voltage drop to five volts at 150% of the rated amperes.

Connecting Cords

To reduce the risk of the cords pulling apart during operation, do one of the following:

- Make a knot as shown below then connect the cords:

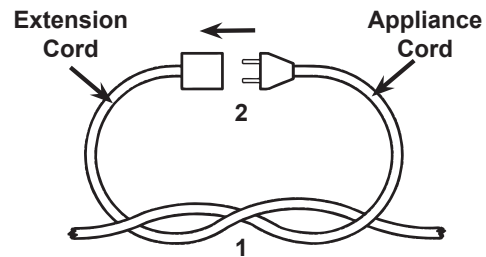

- Or, use a plug-receptacle retaining strap or connector designed to hold extension cords to appliance cords.

Mixer Safety Warnings

- FOR CEMENT AND MORTAR ONLY. DO NOT USE WITH EPOXY 2-PART RESIN MIX.**

WARNING! Do not attempt to move the Cement Mixer when it is full and/or in operation. It is unsafe to move the mixer while in this condition, and severe injury to personnel could occur.

- When servicing use only identical replacement parts.
- Only use safety equipment that has been approved by an appropriate standards agency. Unapproved safety equipment may not provide adequate protection. Eye protection must be ANSI-approved and breathing protection must be NIOSH-approved for the specific hazards in the work area.
- Industrial applications must follow OSHA guidelines.
- Maintain labels and nameplates on the tool. These carry important safety information. If unreadable or missing, contact Harbor Freight Tools for a replacement.
- Avoid unintentional starting. Prepare to begin work before turning on the tool.
- People with pacemakers should consult their physician(s) before use. Electromagnetic fields in close proximity to heart pacemaker could cause pacemaker interference or pacemaker failure.

- WARNING:** Some dust created by power sanding, sawing, grinding, drilling, and other construction activities, contains chemicals known [to the State of California] to cause cancer, birth defects or other reproductive harm. Some examples of these chemicals are:
 - Lead from lead-based paints
 - Crystalline silica from bricks and cement or other masonry products
 - Arsenic and chromium from chemically treated lumberYour risk from these exposures varies, depending on how often you do this type of work. To reduce your exposure to these chemicals: work in a well ventilated area, and work with approved safety equipment, such as those dust masks that are specially designed to filter out microscopic particles. (California Health & Safety Code § 25249.5, *et seq.*)
- WARNING:** Handling the cord on this product will expose you to lead, a chemical known to the State of California to cause cancer, and birth defects or other reproductive harm. Wash hands after handling. (California Health & Safety Code § 25249.5, *et seq.*)
- The warnings, precautions, and instructions discussed in this instruction manual cannot cover all possible conditions and situations that may occur. It must be understood by the operator that common sense and caution are factors which cannot be built into this product, but must be supplied by the operator.

NOTICE

FOR CEMENT AND MORTAR ONLY.
Do not use with Epoxy 2-part resin mix.

Vibration Safety

This tool vibrates during use. Repeated or long-term exposure to vibration may cause temporary or permanent physical injury, particularly to the hands, arms and shoulders. To reduce the risk of vibration-related injury:

1. Anyone using vibrating tools regularly or for an extended period should first be examined by a doctor and then have regular medical check-ups to ensure medical problems are not being caused or worsened from use. Pregnant women or people who have impaired blood circulation to the hand, past hand injuries, nervous system disorders, diabetes, or Raynaud's Disease should not use this tool. If you feel any medical or physical symptoms related to vibration (such as tingling, numbness, and white or blue fingers), seek medical advice as soon as possible.
2. Do not smoke during use. Nicotine reduces the blood supply to the hands and fingers, increasing the risk of vibration-related injury.
3. Wear suitable gloves to reduce the vibration effects on the user.
4. Use tools with the lowest vibration when there is a choice between different processes.
5. Include vibration-free periods each day of work.
6. To reduce vibration, maintain the tool as explained in this manual. If any abnormal vibration occurs, stop use immediately.

Specifications

Electrical Input	120 VAC / 60 Hz / 3.5 A
Motor No Load Speed	1820 RPM
Drum Speed	36 RPM
Drum Capacity	3-1/2 Cubic Feet
Drum Opening	15"



NOTICE

FOR CEMENT AND MORTAR ONLY.
Do not use with Epoxy 2-part resin mix.

Setup - Before Use



Read the **ENTIRE** IMPORTANT SAFETY INFORMATION section at the beginning of this document including all text under subheadings therein before set up or use of this product.

WARNING

TO PREVENT SERIOUS INJURY FROM ACCIDENTAL OPERATION:

Turn the Power Switch of the tool off before performing any procedure in this section.

Note: For additional information regarding the parts listed in the following pages, refer to the Assembly Diagram near the end of this manual.

Assembly/Mounting

1. Place the Stand (78) into the Wheel Bracket (4) so that bolt holes line up. See Figure A.

Note: Set Stand on its side for easier assembly.

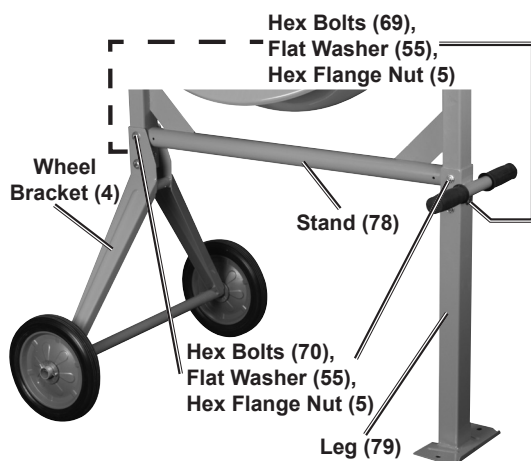

Figure A

2. Fasten together using Hex Bolts (69, 70), Flat Washers (55) and Hex Flange Nuts (5). Tighten with a wrench (not included) until secure.
3. Insert Leg (79) into Stand so that bolt holes line up.
4. Fasten together using Hex Bolts (69, 70), Flat Washers (55) and Hex Flange Nuts (5). Tighten with a wrench until secure.
5. Place Stand upright.

6. To attach Wheels (3) to Wheel Bracket, slide a Flat Washer (2), Wheel and second Flat Washer onto each end of Bracket axle. See Figure B.

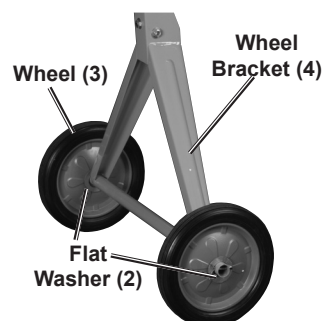

Figure B

7. Insert a Cotter Pin (1) through holes in each end of the Bracket axle and bend the Cotter Pins over to secure the Wheels in place. See Figure C.

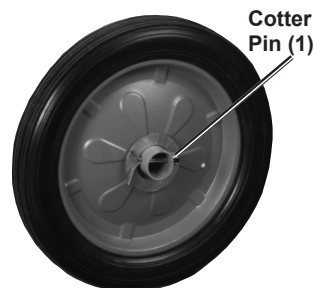

Figure C

NOTICE

FOR CEMENT AND MORTAR ONLY.
Do not use with Epoxy 2-part resin mix.

8. With assistance, set the Lower Drum (48) with attached Arm (77) and Support Bracket Seats (35) into Stand assembly and align the bolt holes. See Figure D.

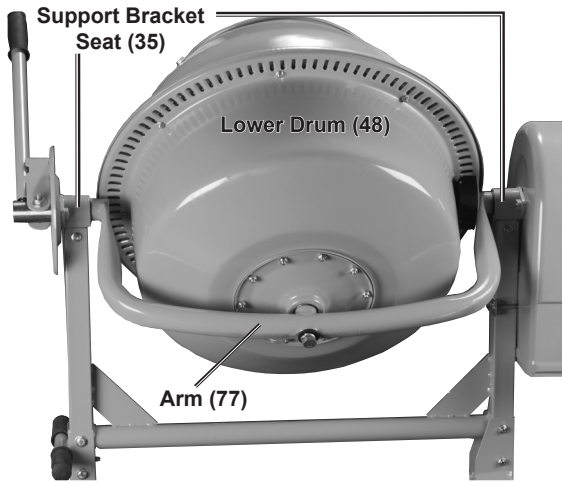

Figure D

9. Fasten together using Hex Bolts (71), Flat Washers (55), and Hex Flange Nuts (5). Tighten with wrench until secure.
10. Mount Handle Control Plate (41) to Support Bracket Seat (35) using Hex Bolts (28), Spring Washers (29) and Flat Washers (30). See Figure E.

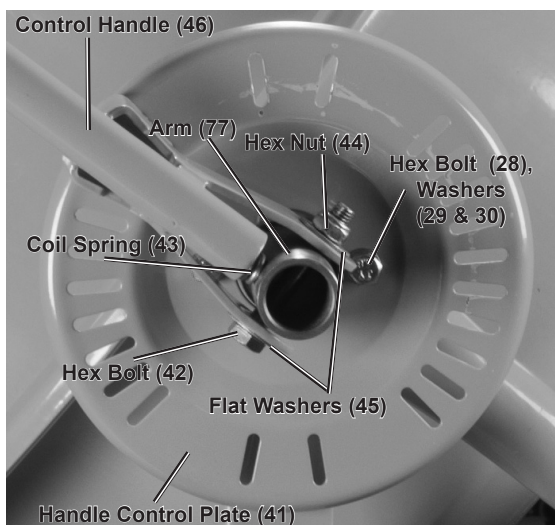

Figure E

11. Tighten to a point where the Arm (77) can still move.
12. Insert the Coil Spring (43) into the Control Handle (46).
13. Attach Control Handle to Arm shaft with a Hex Bolt (42), two Flat Washers (45), and a Hex Nut (44).

14. Use gasket sealer (not included) to stick the Rubber Gasket (60) to the Upper Drum (59), making sure the holes in both align. The Gasket must be flat on the Upper Drum to ensure a proper seal.
15. Place the Upper Drum onto the Lower Drum (48), making sure the mounting holes align in both.
16. Insert a Screw (57) into each of six mounting holes. Fasten Drums together using Flat Washers (58) and Nuts (32).
17. Position each Mixer Blade (62) inside the assembled Drum with the pointed end facing downward. The V-shaped bend in the Blades should point in the direction of the Drum rotation (clockwise).
18. Fasten tops of Mixer Blades to Upper Drum using Hex Bolts (54), Washers (55), Seal Gaskets (56), and Hex Flange Nuts (5). Fasten pointed ends of Mixer Blades to Lower Drum using Hex Bolts (61), Washers (55), Seal Gaskets (56), Rubber Gaskets (63) and Hex Flange Nuts (5).
19. Mount the Motor Hood (31) to the Support Bracket Seat (35) using Hex Bolts (28), Spring Washers (29) and Flat Washers (30).
20. Use Hex Bolts (73), Flat Washers (55), Spring Washers (29) and Clamp (72) to attach the Motor Bracket (6) to the Motor Hood. Tighten connections until secure. See Figure F.

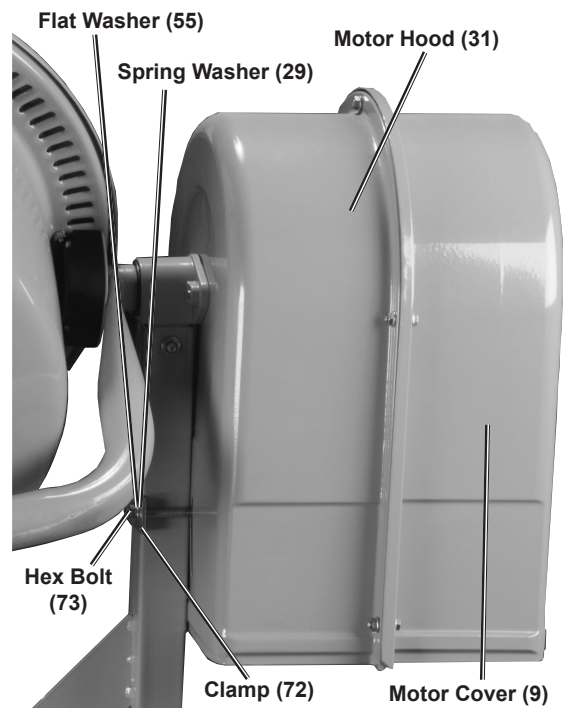

Figure F

SAFETY

SETUP

OPERATION

MAINTENANCE

NOTICE

FOR CEMENT AND MORTAR ONLY.
Do not use with Epoxy 2-part resin mix.

21. Clean the Pinion Shaft (36) of all plastic protective material and other debris. Clean debris out of the Motor Pulley (66) hub.
 22. Spread a few drops of lubricating oil on the Pinion Shaft and squarely push the Drum Pulley (26) onto the Shaft so that the groove in the Pulley engages the Flat Key (25). The Pulley should be flush with the step on the Pinion Shaft.
- Note:** Do not hammer the Drum Pulley onto the Pinion Shaft. Doing so can damage the unit and possibly lead to a loose fitting V-Belt (68).
23. Place the Motor (65) onto the Motor Bracket.
 24. Use Hex Bolts (28), Flat Washers (55) and Hex Flange Nuts (5) to secure the Motor to the Motor Bracket. Hand-tighten all four Hex Nuts since the motor will be adjusted forward or backward later.
 25. Once the Drum Pulley is pushed in all the way, use a hex key (not included) to tighten the Screw on the side of the Pulley's hub.
 26. Attach the V-Belt by placing it around the Motor Pulley (66) and then over the Drum Pulley. Using a flat-edge screwdriver (not included), push the Motor inward until the Motor Pulley is directly under the Drum Pulley. Tighten the Bolts securing the Motor to the Motor Bracket.
 27. Slightly loosen the Hex Bolts (73) holding the Motor Bracket in place. Push the Motor downward until the V-Belt tension is tight. When proper V-Belt tension is achieved, tighten the Hex Bolts (see Belt Inspection and Tensioning on page 12).
 28. Check if Motor and V-Belt turn correctly. Hand turn the Drum Pulley and verify that Motor Pulley and Drum Pulley do not rub against any other part. Adjust Motor location as needed.
 29. Mount the Motor Cover (9) to the Motor Hood (31) using three Hex Bolts (16) and Nuts (32).
- CAUTION!** Make sure that the power cord from the Motor to the Switch (13) does not come in contact with any moving parts.
30. Check all connections to verify that all screws, nuts, and bolts are securely tightened.



NOTICE

FOR CEMENT AND MORTAR ONLY.
Do not use with Epoxy 2-part resin mix.

Operating Instructions



Read the **ENTIRE IMPORTANT SAFETY INFORMATION** section at the beginning of this manual including all text under subheadings therein before set up or use of this product.

Functions

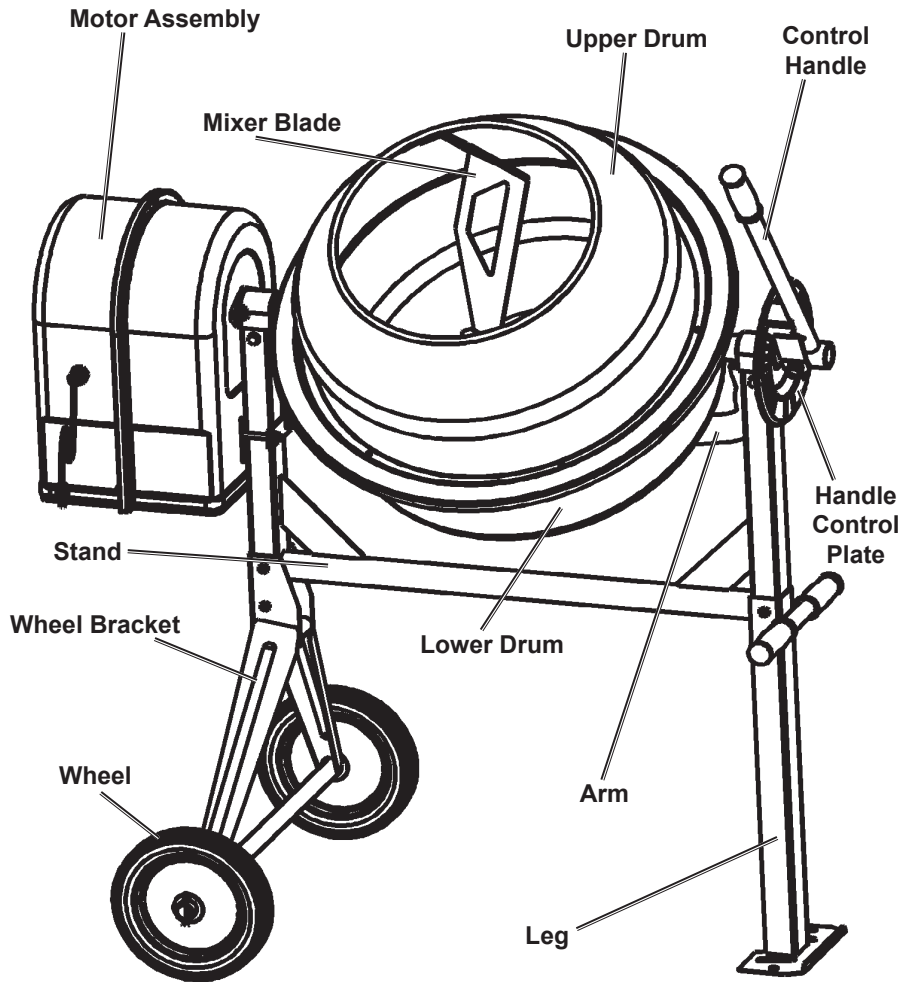

SAFETY

SETUP

OPERATION

MAINTENANCE

NOTICE

FOR CEMENT AND MORTAR ONLY.
Do not use with Epoxy 2-part resin mix.

General Operating Instructions

1. Place the Cement Mixer on a solid, even surface.

WARNING! Do not attempt to move the Cement Mixer when it is full and/or in operation. Block the wheels with wheel chocks (not included).

2. Connect the Power Cord to an electric outlet (or properly rated grounded three prong extension cord).
3. Add material to the Drum. Typical maximum quantities include: 2 gallons water with 3 shovels of cement and 15 shovels aggregate rock (using a size 3 shovel, not included).
4. Adjust the Drum angle by pulling on the Control Handle. First, disengage the locking pins by pulling the Control Handle away from the drum and then pushing on the Handle until the desired angle is reached. Re-engage the locking pins.

5. Flip the switch to "ON" (I) position.

6. Once materials are mixed, tilt Drum and dump materials where needed. The materials are dumped while the Drum is rotating.

CAUTION! Never leave the Cement Mixer running while unattended. Do not turn Mixer off while full of cement.

7. When finished, flip the Switch to the "OFF" (O) position and disconnect the Power Cord.
8. Tilt the Drum angle as far down as possible to drain all fluids from Drum.
9. Clean, then store out of children's reach.

SAFETY

SETUP

OPERATION

MAINTENANCE



NOTICE

FOR CEMENT AND MORTAR ONLY.
Do not use with Epoxy 2-part resin mix.

Maintenance and Servicing



Procedures not specifically explained in this manual must be performed only by a qualified technician.

⚠️ WARNING

TO PREVENT SERIOUS INJURY FROM ACCIDENTAL OPERATION: Turn the Power Switch of the tool to its "OFF" position and unplug the tool from its electrical outlet before performing any inspection, maintenance, or cleaning procedures.

TO PREVENT SERIOUS INJURY FROM TOOL FAILURE:

Do not use damaged equipment. If abnormal noise or vibration occurs, have the problem corrected before further use.

Cleaning, Maintenance, and Lubrication

- BEFORE EACH USE**, inspect the general condition of the tool. Check for:
 - Loose hardware
 - Misalignment or binding of moving parts
 - Cracked or broken parts
 - Damaged electrical wiring
 - Damaged or cracked belts
 - Any other condition that may affect its safe operation.
- AFTER USE**, immediately wash out all debris from the inside and outside of the Cement Mixer. Scrub the inside of the Drum with a stiff, long handled bristle brush for best results. Wipe external surfaces of the tool with clean cloth.
- DO NOT apply water in or around the Motor Cover.
- PERIODICALLY** recheck all fasteners and other connections for tightness.
- ⚠️ WARNING!** If the supply cord of this power tool is damaged, it must be replaced only by a qualified service technician.

Belt Inspection and Tensioning

- Retighten V-Belt after the first 25 hours of use. To test the tension, follow the steps below.
- Remove Motor Cover.
- Examine Belt for cracks, tears in the backing, or other damage. Replace Belt if damaged according to steps below:
 - Loosen the Motor Bracket bolts and slide the Bracket up as far as possible.
 - Slide the old Belt off of the Drum Pulley first, then remove it from the Motor Pulley.
 - Put the new belt around the Motor Pulley first, then around the Drum Pulley.
 - Move the Motor Bracket down until the Belt is properly tensioned according to the directions below. Tighten the Motor Bracket bolts.
- Check and adjust belt tension according to the steps below:

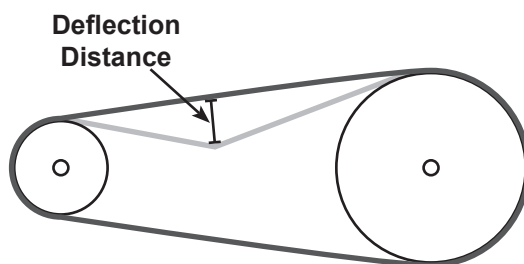

- Press on the center of the longest span on the belt with moderate finger pressure. Then measure the deflection distance, the distance that the belt moved. The belt should deflect anywhere from 1/2" to 3/4".
 - If the belt deflects too much**, tighten belt by loosening the Motor Bracket bolts and moving the Motor away from the Drum Pulley slightly. Tighten Motor Bracket bolts and retest tension. If the belt is too long to be properly tensioned, it must be replaced.
 - If the belt deflects too little**, loosen the Motor Bracket bolts and lift Bracket upward. Tighten Motor Bracket bolts and retest tension.
- Replace Motor Cover.

NOTICE

FOR CEMENT AND MORTAR ONLY.
Do not use with Epoxy 2-part resin mix.

Troubleshooting

Problem	Possible Causes	Likely Solutions
Tool will not start.	<ol style="list-style-type: none"> 1. Cord not connected. 2. No power at outlet. 3. Internal damage or wear. 	<ol style="list-style-type: none"> 1. Check that cord is plugged in. 2. Check power at outlet. If outlet is unpowered, turn off tool and check circuit breaker. If breaker is tripped, make sure circuit has the correct capacity for the tool and circuit has no other loads. 3. Have technician service tool.
Tool operates slowly.	Extension cord too long or wire size too small.	Eliminate use of extension cord. If an extension cord is needed, use shorter/heavier gauge cord. See <i>Extension Cords</i> in <i>GROUNDING</i> section.
Excessive noise or rattling.	<ol style="list-style-type: none"> 1. Belt too loose (slipping) or too tight (bearing damage). 2. Internal damage or wear. 	<ol style="list-style-type: none"> 1. Properly tension belt. 2. Have technician service tool.
Overheating/ Overloading.	<ol style="list-style-type: none"> 1. Running at 100% load for extended time. 2. Blocked motor housing vents. 3. Motor being strained by long or small diameter extension cord. 	<ol style="list-style-type: none"> 1. Allow for lighter no-load intervals. 2. Wear ANSI-approved safety goggles and NIOSH-approved dust mask/respirator while blowing dust out of motor using compressed air. 3. Eliminate use of extension cord. If an extension cord is needed, use one with the proper diameter for its length and load. See <i>Extension Cords</i> in <i>GROUNDING</i> section.



**Follow all safety precautions whenever diagnosing or servicing the tool.
Disconnect power supply before service.**

SAFETY

SETUP

OPERATION

MAINTENANCE

NOTICE

FOR CEMENT AND MORTAR ONLY.
Do not use with Epoxy 2-part resin mix.

Parts List and Diagram**Parts List**

Part	Description	Qty
1	Cotter Pin 5×40	2
2	Flat Washer 27	4
3	Wheel	2
4	Wheel Bracket	1
5	Hex Flange Nut M8	18
6	Motor Bracket	1
7	Power Cord	1
8	Bushing M12	3
9	Motor Cover	1
10	Flat Washer 4	15
11	Cross-Head Screw M4×12	4
12	Screw ST3.5×9.5	4
13	Switch	1
14	Switch Panel	1
15	Overload Protection Device 5A	1
16	Hex Bolt M6×20	5
17	Spring Washer 4	4
18	Nut M4	4
19	Ground Wire	1
20	Serrated Washer	1
21	Terminal Box	1
22	Cross-Head Screw M6×15	2
23	Spring Washer 6	2
24	Flat Washer 6	2
25	Flat Key 5×35	1
26	Drum Pulley	1
27	Spacer	2
28	Hex Bolt M8×20	4
29	Spring Washer 8	6
30	Flat Washer 8	4
31	Motor Hood	1
32	Nut M6	13
33	Bearing 6002ZZ	2
34	Ring Shield Ø38	4
35	Support Bracket Seat	2
36	Pinion Shaft	1
37	Gear	1
38	Flat Key 5×12	1
39	Gear Cover	1
40	Cross-Head Screw M4×30	3

Part	Description	Qty
41	Handle Control Plate	1
42	Hex Bolt M10×70	1
43	Coil Spring	1
44	Nut M10	1
45	Flat Washer 10	2
46	Control Handle	1
47	Rubber Handle	3
48	Lower Drum	1
49	Bearing Cover, Upper	1
50	Bearing 6206Z	2
51	Shaft	1
52	Nut M8	6
53	Bearing Cover, Lower	1
54	Hex Bolt M8×16	10
55	Flat Washer 8	26
56	Seal Gasket	18
57	Bolt M6x16	8
58	Flat Washer 6	8
59	Upper Drum	1
60	Rubber Gasket	1
61	Hex Bolt M8×20	2
62	Mixer Blade	2
63	Rubber Gasket	2
64	Flat Key 5×25	1
65	Motor	1
66	Motor Pulley	1
67	Screw M6×12	1
68	V-Belt O-870	1
69	Hex Bolt M8×55	2
70	Hex Bolt M8×65	4
71	Hex Bolt M8×60	2
72	Clamp	1
73	Hex Bolt M8×70	2
74	Hex Bolt M14×30	1
75	Spring Washer 14	1
76	Flat Washer	1
77	Arm	1
78	Stand	1
79	Leg	1

SAFETY

SETUP

OPERATION

MAINTENANCE

NOTICE

FOR CEMENT AND MORTAR ONLY.
Do not use with Epoxy 2-part resin mix.

Assembly Diagram

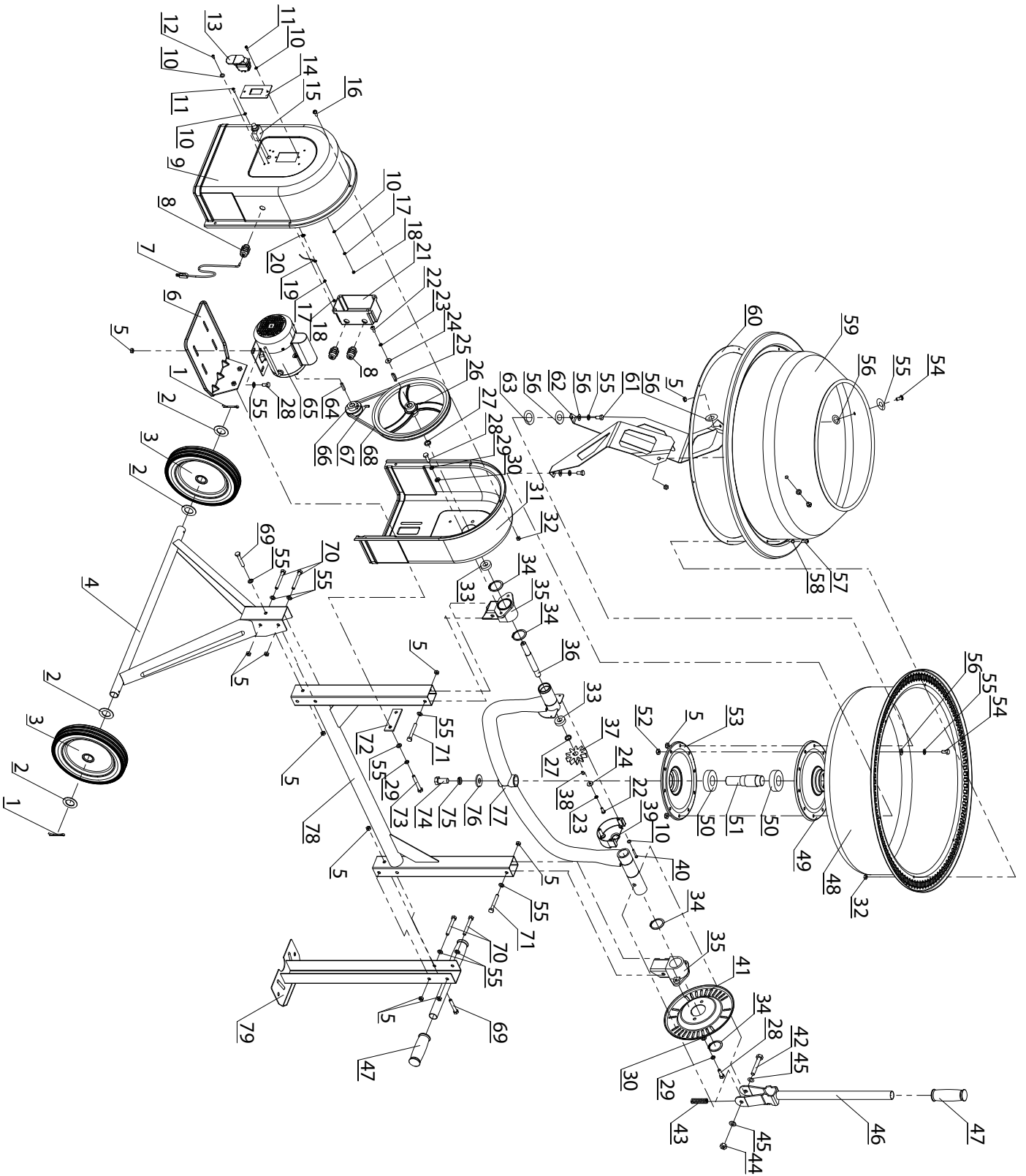

Record Serial Number Here:

Note: If product has no serial number, record month and year of purchase instead.

Note: Some parts are listed and shown for illustration purposes only, and are not available individually as replacement parts.

PLEASE READ THE FOLLOWING CAREFULLY

THE MANUFACTURER AND/OR DISTRIBUTOR HAS PROVIDED THE PARTS LIST AND ASSEMBLY DIAGRAM IN THIS DOCUMENT AS A REFERENCE TOOL ONLY. NEITHER THE MANUFACTURER OR DISTRIBUTOR MAKES ANY REPRESENTATION OR WARRANTY OF ANY KIND TO THE BUYER THAT HE OR SHE IS QUALIFIED TO MAKE ANY REPAIRS TO THE PRODUCT, OR THAT HE OR SHE IS QUALIFIED TO REPLACE ANY PARTS OF THE PRODUCT. IN FACT, THE MANUFACTURER AND/OR DISTRIBUTOR EXPRESSLY STATES THAT ALL REPAIRS AND PARTS REPLACEMENTS SHOULD BE UNDERTAKEN BY CERTIFIED AND LICENSED TECHNICIANS, AND NOT BY THE BUYER. THE BUYER ASSUMES ALL RISK AND LIABILITY ARISING OUT OF HIS OR HER REPAIRS TO THE ORIGINAL PRODUCT OR REPLACEMENT PARTS THERETO, OR ARISING OUT OF HIS OR HER INSTALLATION OF REPLACEMENT PARTS THERETO.

Limited 90 Day Warranty

Harbor Freight Tools Co. makes every effort to assure that its products meet high quality and durability standards, and warrants to the original purchaser that this product is free from defects in materials and workmanship for the period of 90 days from the date of purchase. This warranty does not apply to damage due directly or indirectly, to misuse, abuse, negligence or accidents, repairs or alterations outside our facilities, criminal activity, improper installation, normal wear and tear, or to lack of maintenance. We shall in no event be liable for death, injuries to persons or property, or for incidental, contingent, special or consequential damages arising from the use of our product. Some states do not allow the exclusion or limitation of incidental or consequential damages, so the above limitation of exclusion may not apply to you. THIS WARRANTY IS EXPRESSLY IN LIEU OF ALL OTHER WARRANTIES, EXPRESS OR IMPLIED, INCLUDING THE WARRANTIES OF MERCHANTABILITY AND FITNESS.

To take advantage of this warranty, the product or part must be returned to us with transportation charges prepaid. Proof of purchase date and an explanation of the complaint must accompany the merchandise. If our inspection verifies the defect, we will either repair or replace the product at our election or we may elect to refund the purchase price if we cannot readily and quickly provide you with a replacement. We will return repaired products at our expense, but if we determine there is no defect, or that the defect resulted from causes not within the scope of our warranty, then you must bear the cost of returning the product.

This warranty gives you specific legal rights and you may also have other rights which vary from state to state.

