

Specifications, Parts List & Diagram

Save This Manual Keep this manual for the safety warnings and precautions, assembly, operating, inspection, maintenance and cleaning procedures. Write the product's serial number in the back of the manual near the assembly diagram (or month and year of purchase if product has no number). Keep this manual and the receipt in a safe and dry place for future reference.

CENTRALPNEUMATIC®

3" high speed air cutter

Specifications

Maximum Wheel Size	3" Dia.
Arbor Size	3/8"
Maximum Pressure	90 PSI
Air Inlet Fitting Size	1/4" - 18 NPT Female
Rated Speed*	20,000 RPM
Air Consumption	5 CFM @ 90 PSI
Accessories	Hex Key, Wrench

* Rated speed at stated maximum air pressure.
Excess air pressure is hazardous and may cause the tool to exceed stated speed.



Visit our website at: <http://www.harborfreight.com>
Email our technical support at: tech@harborfreight.com

ITEM 60374

When unpacking, make sure that the product is intact and undamaged. If any parts are missing or broken, please call 1-800-444-3353 as soon as possible.

Copyright© 2012 by Harbor Freight Tools®. All rights reserved.
No portion of this manual or any artwork contained herein may be reproduced in any shape or form without the express written consent of Harbor Freight Tools. Diagrams within this manual may not be drawn proportionally. Due to continuing improvements, actual product may differ slightly from the product described herein. Tools required for assembly and service may not be included.

⚠ WARNING

Read the separate High Speed Air Cutter Safety Warnings, Installation and Operation Instructions before using this product. Failure to do so can result in serious injury. **SAVE THIS SPECIFICATION SHEET AND THE HIGH SPEED AIR CUTTER SAFETY WARNINGS, INSTALLATION AND OPERATION INSTRUCTIONS FOR FUTURE REFERENCE.**

PLEASE READ THE FOLLOWING CAREFULLY

THE MANUFACTURER AND/OR DISTRIBUTOR HAS PROVIDED THE PARTS LIST AND ASSEMBLY DIAGRAM IN THIS MANUAL AS A REFERENCE TOOL ONLY. NEITHER THE MANUFACTURER OR DISTRIBUTOR MAKES ANY REPRESENTATION OR WARRANTY OF ANY KIND TO THE BUYER THAT HE OR SHE IS QUALIFIED TO MAKE ANY REPAIRS TO THE PRODUCT, OR THAT HE OR SHE IS QUALIFIED TO REPLACE ANY PARTS OF THE PRODUCT. IN FACT, THE MANUFACTURER AND/OR DISTRIBUTOR EXPRESSLY STATES THAT ALL REPAIRS AND PARTS REPLACEMENTS SHOULD BE UNDERTAKEN BY CERTIFIED AND LICENSED TECHNICIANS, AND NOT BY THE BUYER. THE BUYER ASSUMES ALL RISK AND LIABILITY ARISING OUT OF HIS OR HER REPAIRS TO THE ORIGINAL PRODUCT OR REPLACEMENT PARTS THERETO, OR ARISING OUT OF HIS OR HER INSTALLATION OF REPLACEMENT PARTS THERETO.

Parts List and Assembly Diagram

Part	Description	Qty
1	Air Inlet	1
2	Cover	1
3	Throttle Lever	1
4	Spring Pin	1
5	Spring Pin	1
6	Spring	1
7	Safety Lock	1
8	Washer	1
10	O-Ring	1
11	O-Ring	1
12	Throttle Valve	1
13	Extended Spring	1

Part	Description	Qty
14	Air Regulator	1
15	O-Ring	1
16	O-Ring	1
17	Valve Screw	1
18	Housing	1
19	Bearing	1
20	Rear End Plate	1
21	Steel Ball	1
22	Cylinder	1
23	Rotor Blade	4
24	Rotor	1
25	Washer	1

Part	Description	Qty
26	Steel Ball	2
27	Front End Plate	1
28	Bearing	1
29	Guard	1
30	Gasket	1
31	Clamp Nut	1
32	Spindle	1
33	3" Cutting Disc	-
34	Gasket	1
35	Bolt	1
36	Wrench	1
37	Hex Key	1

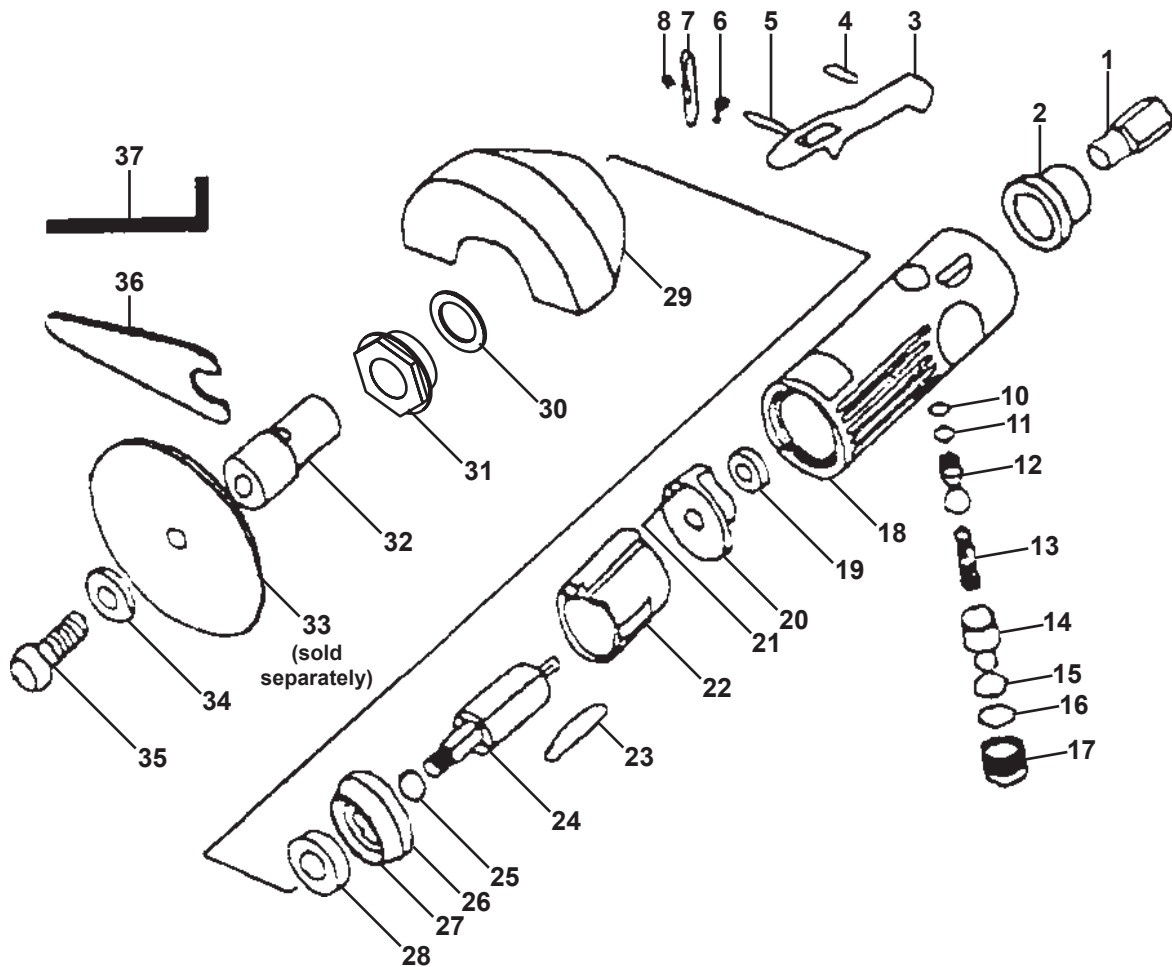

Record Product's Serial Number Here: _____

Note: If product has no serial number, record month and year of purchase instead.

Note: Some parts are listed and shown for illustration purposes only, and are not available individually as replacement parts.