

Owner's Manual & Safety Instructions

Save This Manual Keep this manual for the safety warnings and precautions, assembly, operating, inspection, maintenance and cleaning procedures. Write the product's serial number in the back of the manual near the assembly diagram (or month and year of purchase if product has no number). Keep this manual and the receipt in a safe and dry place for future reference.

Item 95736



47 Bin, Floor Mount Parts Rack



REV 13b

Visit our website at: <http://www.harborfreight.com>
Email our technical support at: tech@harborfreight.com

When unpacking, make sure that the product is intact and undamaged. If any parts are missing or broken, please call 1-800-444-3353 as soon as possible.

Copyright© 2007 by Harbor Freight Tools®. All rights reserved.
No portion of this manual or any artwork contained herein may be reproduced in any shape or form without the express written consent of Harbor Freight Tools. Diagrams within this manual may not be drawn proportionally. Due to continuing improvements, actual product may differ slightly from the product described herein.
Tools required for assembly and service may not be included.

⚠ WARNING

**Read this material before using this product.
Failure to do so can result in serious injury.
SAVE THIS MANUAL.**

Specifications

Overall Assembled Rack Dimensions	37"L x 11-1/4"W x 45-1/4"H
Small Bin Dimensions	(32) 6-1/2"L x 4-1/8"W x 3"H
Large Bin Dimensions	(15) 9-1/4"L x 6"W x 5"H
Maximum Weight Capacity	Overall Parts Rack: 171 Lb. Large Bin: 5 Lb. each Small Bin: 3 Lb. each

IMPORTANT SAFETY INFORMATION

Assembly Precautions

1. Assemble only according to these instructions. Improper assembly can create hazards.
2. Wear ANSI-approved safety goggles and heavy-duty work gloves during assembly.
3. Keep assembly area clean and well lit.
4. Keep bystanders out of the area during assembly.
5. Do not assemble when tired or when under the influence of alcohol, drugs or medication.
6. Weight capacity and other product capabilities apply to properly and completely assembled product only.
7. Stay alert. Watch what you are doing and use common sense during assembly and use of this product.
8. During assembly dress properly. Do not wear loose clothing or jewelry. Contain long hair.
9. Do not overreach. Keep proper footing and balance at all times.

Use Precautions

1. This product is not a toy. Do not allow children to play with or near this item.
2. Use as intended only.
3. Inspect before every use; do not use if parts are loose or damaged.
4. Do not exceed listed weight capacity.
5. Maintain product labels and nameplates. These carry important safety information. If unreadable or missing, contact Harbor Freight Tools for a replacement.
6. Do not force the product. Use the correct product for your application. The correct product will do the job better and safer at the rate for which it is designed. Do not force the product and do not use it for a purpose for which it is not intended.
7. Locate the Parts Rack out of reach of children and other untrained persons. The Parts Rack is designed to hold small parts which can be easily swallowed by small children. Keep children away.
8. Maintain this product with care.
9. Use only accessories that are recommended by the manufacturer for your model. Accessories that may be suitable for one product may become hazardous when used on another product.
10. Use on a flat, level surface capable of supporting the Parts Rack and its contents.
11. Load hardware evenly. As much as possible, distribute the weight of all materials stored in this Parts Rack evenly.
12. Do not use this Parts Rack as a stepping stool or ladder. Never sit, stand, or climb on this Parts Rack.
13. Do not overload or over-stack this Parts Rack. Overloading can damage bins and could possibly result in tipping and personal injury. Over-stacking can result in tools or other objects sliding or falling from the Parts Rack and could result in damaged tools and/or personal injury.



SAVE THESE INSTRUCTIONS.

Assembly Instructions



Read the **ENTIRE IMPORTANT SAFETY INFORMATION** section at the beginning of this document including all text under subheadings therein before set up or use of this product.

Note: For additional information regarding the parts listed in the following pages, refer to Parts List and Assembly Diagram on page 6.

1. Attach ends of Hanging Bars (4) to left Column (2). Secure with Bolts (5) and Nuts (8). Attach other ends to right Column. Secure with Bolts (5) and Nuts (8). (See Figure A.)

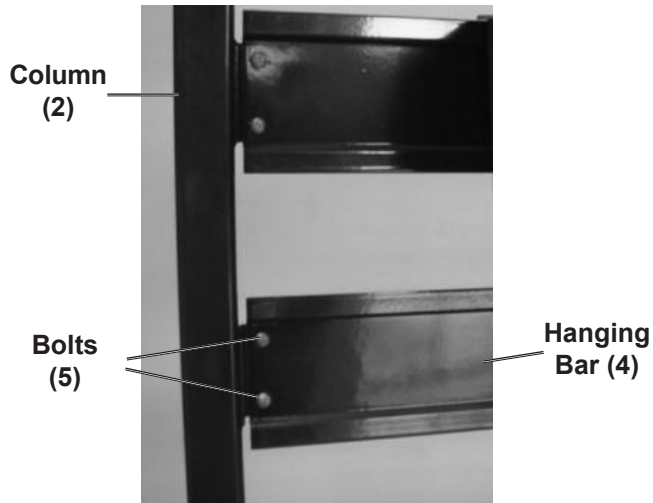

Figure A

3. Secure one Column Support (3) to each Column with Bolts (9) and Spring Washers (11).
4. Secure Columns to Bottom Plate (10) with Bolts (9) and Spring Washers (11).
5. Secure Column Supports to Bottom Plate with Bolts (9) and Spring Washers (11). (See Figure C.)

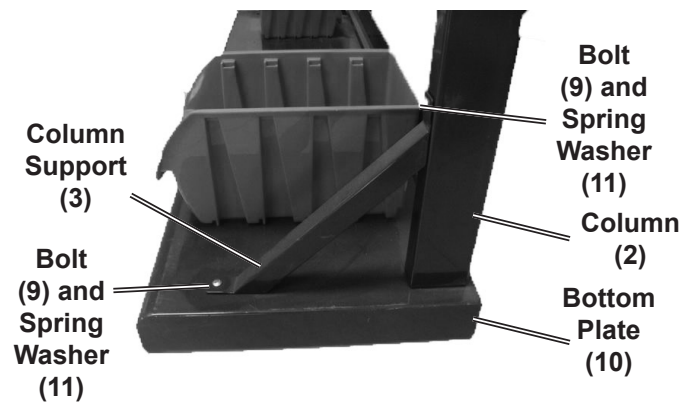

Figure C

2. Attach Hanging Bar Support (7) to center of Hanging Bars. Secure with Bolts (6). (See Figure B.)

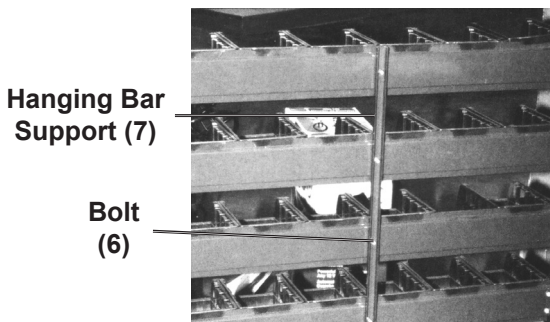

Figure B

6. Secure Top Cover (1) to Columns with Bolts (9) and Spring Washers (11).
7. Arrange Bins as desired. Slide Bin Lip over Hanging Bar, making certain Bin is securely in place. (See Figure D.)

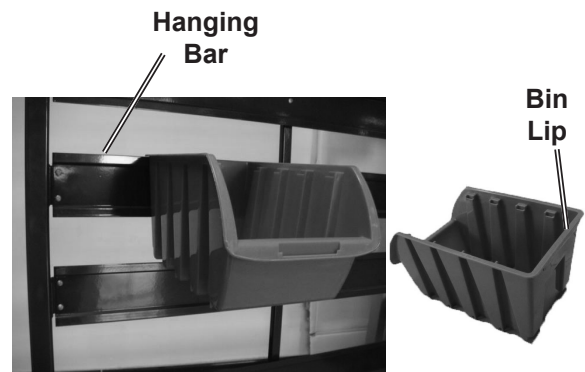

Figure D

8. Set up the Parts Rack in desired location. Make certain it is on a flat, even and stable surface capable of supporting rated weight capacity.
9. Fill Bins as desired.

Cleaning

1. Clean the Floor Rack with a damp cloth. Do not use abrasives, harsh chemicals or detergents as these will scratch and damage the Bins and frame.

PLEASE READ THE FOLLOWING CAREFULLY

THE MANUFACTURER AND/OR DISTRIBUTOR HAS PROVIDED THE PARTS LIST AND ASSEMBLY DIAGRAM IN THIS DOCUMENT AS A REFERENCE TOOL ONLY. NEITHER THE MANUFACTURER OR DISTRIBUTOR MAKES ANY REPRESENTATION OR WARRANTY OF ANY KIND TO THE BUYER THAT HE OR SHE IS QUALIFIED TO MAKE ANY REPAIRS TO THE PRODUCT, OR THAT HE OR SHE IS QUALIFIED TO REPLACE ANY PARTS OF THE PRODUCT. IN FACT, THE MANUFACTURER AND/OR DISTRIBUTOR EXPRESSLY STATES THAT ALL REPAIRS AND PARTS REPLACEMENTS SHOULD BE UNDERTAKEN BY CERTIFIED AND LICENSED TECHNICIANS, AND NOT BY THE BUYER. THE BUYER ASSUMES ALL RISK AND LIABILITY ARISING OUT OF HIS OR HER REPAIRS TO THE ORIGINAL PRODUCT OR REPLACEMENT PARTS THERETO, OR ARISING OUT OF HIS OR HER INSTALLATION OF REPLACEMENT PARTS THERETO.

Parts List and Assembly Diagram

Parts List

Part	Description	Qty
1	Top Cover	1
2	Column	2
3	Column Support	2
4	Hanging Bar	7
5	Bolt (M4x8)	28
6	Bolt (M4x16)	7
7	Hanging Bar Support	1

Part	Description	Qty
8	Nut (M4)	28
9	Bolt (M4x14)	12
10	Bottom Plate	1
11	Spring Washer	12
12	Small Bin	32
13	Large Bin (not shown)	15

Record Serial Number Here:

Note: If product has no serial number, record month and year of purchase instead.

Note: Some parts are listed and shown for illustration purposes only, and are not available individually as replacement parts.

Assembly Diagram

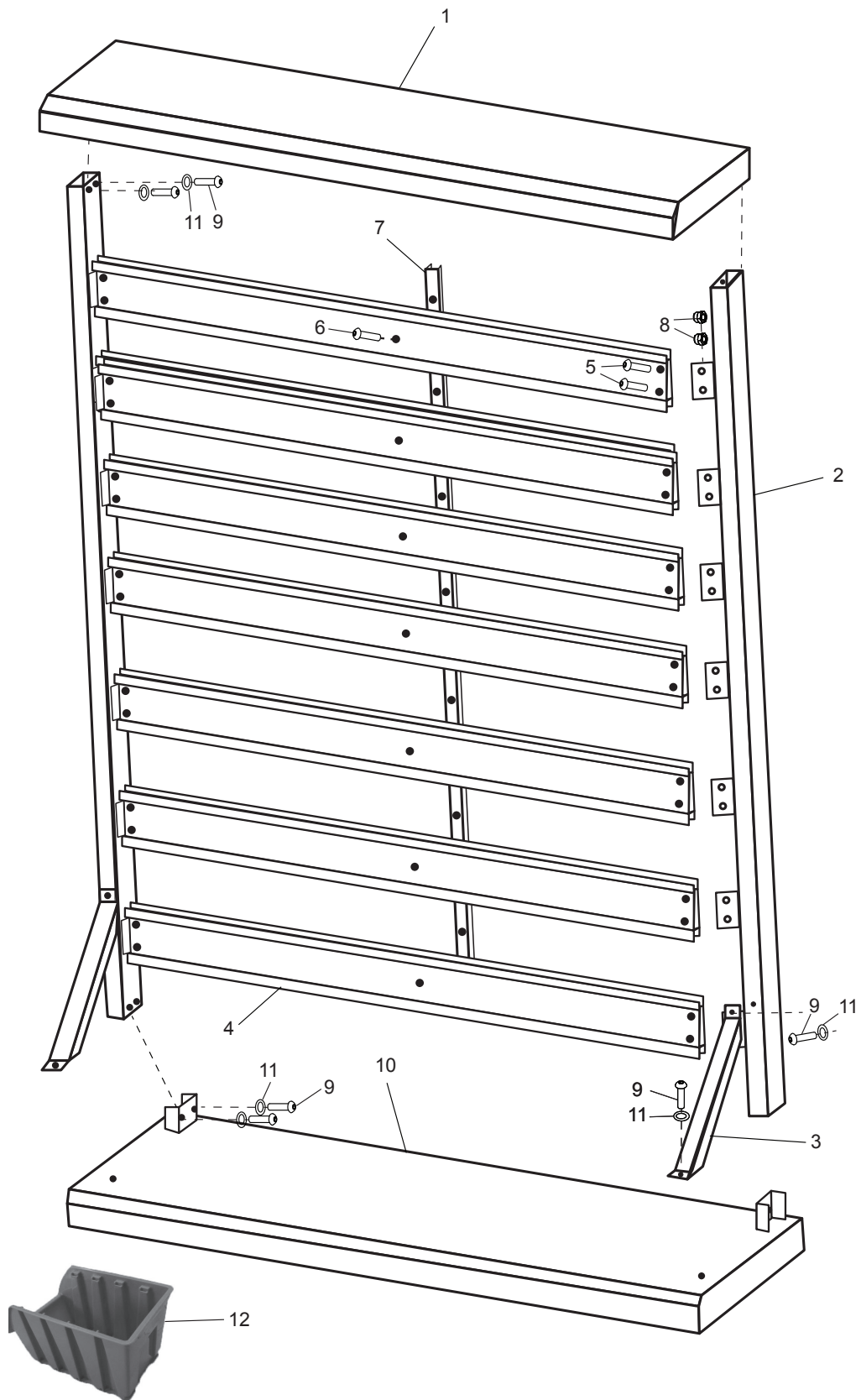

Limited 90 Day Warranty

Harbor Freight Tools Co. makes every effort to assure that its products meet high quality and durability standards, and warrants to the original purchaser that this product is free from defects in materials and workmanship for the period of 90 days from the date of purchase. This warranty does not apply to damage due directly or indirectly, to misuse, abuse, negligence or accidents, repairs or alterations outside our facilities, criminal activity, improper installation, normal wear and tear, or to lack of maintenance. We shall in no event be liable for death, injuries to persons or property, or for incidental, contingent, special or consequential damages arising from the use of our product. Some states do not allow the exclusion or limitation of incidental or consequential damages, so the above limitation of exclusion may not apply to you. THIS WARRANTY IS EXPRESSLY IN LIEU OF ALL OTHER WARRANTIES, EXPRESS OR IMPLIED, INCLUDING THE WARRANTIES OF MERCHANTABILITY AND FITNESS.

To take advantage of this warranty, the product or part must be returned to us with transportation charges prepaid. Proof of purchase date and an explanation of the complaint must accompany the merchandise. If our inspection verifies the defect, we will either repair or replace the product at our election or we may elect to refund the purchase price if we cannot readily and quickly provide you with a replacement. We will return repaired products at our expense, but if we determine there is no defect, or that the defect resulted from causes not within the scope of our warranty, then you must bear the cost of returning the product.

This warranty gives you specific legal rights and you may also have other rights which vary from state to state.

