

Owner's Manual & Safety Instructions

Save This Manual Keep this manual for the safety warnings and precautions, assembly, operating, inspection, maintenance and cleaning procedures. Write the product's serial number in the back of the manual near the assembly diagram (or month and year of purchase if product has no number). Keep this manual and the receipt in a safe and dry place for future reference.

drillmaster®

ITEM 69079

120 VOLT

7-1/4"

Circular Saw



Blade Sold Separately

Visit our website at: <http://www.harborfreight.com>
Email our technical support at: tech@harborfreight.com

REV 13e

When unpacking, make sure that the product is intact and undamaged. If any parts are missing or broken, please call 1-800-444-3353 as soon as possible.

⚠ WARNING

**Read this material before using this product.
Failure to do so can result in serious injury.
SAVE THIS MANUAL.**





Copyright© 2011 by Harbor Freight Tools®. All rights reserved.
No portion of this manual or any artwork contained herein may be reproduced in any shape or form without the express written consent of Harbor Freight Tools. Diagrams within this manual may not be drawn proportionally. Due to continuing improvements, actual product may differ slightly from the product described herein. Tools required for assembly and service may not be included.

Table of Contents

Safety	2	Maintenance	13
Specifications	10	Parts List and Diagram	14
Setup	10	Warranty	16
Operation.....	11		

CHICAGO ELECTRIC[®] POWER TOOLS

WARNING SYMBOLS AND DEFINITIONS

	This is the safety alert symbol. It is used to alert you to potential personal injury hazards. Obey all safety messages that follow this symbol to avoid possible injury or death.
	Indicates a hazardous situation which, if not avoided, will result in death or serious injury.
	Indicates a hazardous situation which, if not avoided, could result in death or serious injury.
	Indicates a hazardous situation which, if not avoided, could result in minor or moderate injury.
	Addresses practices not related to personal injury.

IMPORTANT SAFETY INFORMATION

General Power Tool Safety Warnings

WARNING

Read all safety warnings and instructions.

Failure to follow the warnings and instructions may result in electric shock, fire and/or serious injury.

Save all warnings and instructions for future reference.

The term "power tool" in the warnings refers to your mains-operated (corded) power tool.

Work Area Safety

- 1. Keep work area clean and well lit.**
Cluttered or dark areas invite accidents.
- 2. Do not operate power tools in explosive atmospheres, such as in the presence of flammable liquids, gases or dust.** *Power tools create sparks which may ignite the dust or fumes.*
- 3. Keep children and bystanders away while operating a power tool.**
Distractions can cause you to lose control.

Electrical Safety

- 1. Power tool plugs must match the outlet.**
Never modify the plug in any way.
Do not use any adapter plugs with grounded power tools. *Unmodified plugs and matching outlets will reduce risk of electric shock.*
- 2. Avoid body contact with grounded surfaces such as pipes, radiators, ranges and refrigerators.** *There is an increased risk of electric shock if your body is grounded.*
- 3. Do not expose power tools to rain or wet conditions.** *Water entering a power tool will increase the risk of electric shock.*
- 4. Do not abuse the cord.** Never use the cord for carrying, pulling or unplugging the power tool. Keep cord away from heat, oil, sharp edges or moving parts. *Damaged or entangled cords increase the risk of electric shock.*
- 5. When operating a power tool outdoors, use an extension cord suitable for outdoor use.** *Use of a cord suitable for outdoor use reduces the risk of electric shock.*
- 6. If operating a power tool in a damp location is unavoidable, use a Ground Fault Circuit Interrupter (GFCI) protected supply.** *Use of a GFCI reduces the risk of electric shock.*

Personal Safety

- 1. Stay alert, watch what you are doing and use common sense when operating a power tool.**
Do not use a power tool while you are tired or under the influence of drugs, alcohol or medication. *A moment of inattention while operating power tools may result in serious personal injury.*
- 2. Use personal protective equipment.** Always wear eye protection. *Safety equipment such as dust mask, non-skid safety shoes, hard hat, or hearing protection used for appropriate conditions will reduce personal injuries.*
- 3. Prevent unintentional starting.** Ensure the switch is in the off-position before connecting to power source, picking up or carrying the tool. *Carrying power tools with your finger on the switch or energizing power tools that have the switch on invites accidents.*
- 4. Remove any adjusting key or wrench before turning the power tool on.**
A wrench or a key left attached to a rotating part of the power tool may result in personal injury.
- 5. Do not overreach.** Keep proper footing and balance at all times. *This enables better control of the power tool in unexpected situations.*
- 6. Dress properly.** Do not wear loose clothing or jewelry. Keep your hair, clothing and gloves away from moving parts. *Loose clothes, jewelry or long hair can be caught in moving parts.*
- 7. If devices are provided for the connection of dust extraction and collection facilities, ensure these are connected and properly used.** *Use of these devices can reduce dust-related hazards.*
- 8. Only use safety equipment that has been approved by an appropriate standards agency.** *Unapproved safety equipment may not provide adequate protection. Eye protection must be ANSI-approved and breathing protection must be NIOSH-approved for the specific hazards in the work area.*

Power Tool Use and Care

1. **Do not force the power tool.** Use the correct power tool for your application. *The correct power tool will do the job better and safer at the rate for which it was designed.*
2. **Do not use the power tool if the switch does not turn it on and off.** *Any power tool that cannot be controlled with the switch is dangerous and must be repaired.*
3. **Disconnect the plug from the power source before making any adjustments, changing accessories, or storing power tools.** *Such preventive safety measures reduce the risk of starting the power tool accidentally.*
4. **Store idle power tools out of the reach of children and do not allow persons unfamiliar with the power tool or these instructions to operate the power tool.** *Power tools are dangerous in the hands of untrained users.*
5. **Maintain power tools.** Check for misalignment or binding of moving parts, breakage of parts and any other condition that may affect the power tool's operation. If damaged, have the power tool repaired before use. *Many accidents are caused by poorly maintained power tools.*
6. **Keep cutting tools sharp and clean.** *Properly maintained cutting tools with sharp cutting edges are less likely to bind and are easier to control.*
7. **Use the power tool, accessories and tool bits etc. in accordance with these instructions, taking into account the working conditions and the work to be performed.** *Use of the power tool for operations different from those intended could result in a hazardous situation.*

Service

Have your power tool serviced by a qualified repair person using only identical replacement parts. *This will ensure that the safety of the power tool is maintained.*

Circular Saw Safety Warnings

1. **⚠ DANGER: Keep hands away from cutting area and the blade. Keep your second hand on auxiliary handle, or motor housing. If both hands are holding the saw, they cannot be cut by the blade.**
2. **Do not reach underneath the workpiece.**
The guard cannot protect you from the blade below the workpiece.
3. **Adjust the cutting depth to the thickness of the workpiece. Less than a full tooth of the blade teeth should be visible below the workpiece.**
4. **Never hold piece being cut in your hands or across your leg.** Secure the workpiece to a stable platform. *It is important to support the work properly to minimize body exposure, blade binding, or loss of control.*
5. **Hold power tool by insulated gripping surfaces when performing an operation where the cutting tool may contact hidden wiring or its own cord.** *Contact with a "live" wire will also make exposed metal parts of the power tool "live" and shock the operator.*
6. **When ripping always use a rip fence or straight edge guide.** *This improves the accuracy of cut and reduces the chance of blade binding.*
7. **Always use blades with correct size and shape (diamond versus round) of arbor holes.** *Blades that do not match the mounting hardware of the saw will run eccentrically, causing loss of control.*
8. **Never use damaged or incorrect blade washers or bolt.** *The blade washers and bolt were specially designed for your saw, for optimum performance and safety of operation.*
9. **Causes and Operator Prevention of Kickback:**
 - Kickback is a sudden reaction to a pinched, bound or misaligned saw blade, causing an uncontrolled saw to lift up and out of the workpiece toward the operator;
 - When the blade is pinched or bound tightly by the kerf closing down, the blade stalls and the motor reaction drives the unit rapidly back toward the operator;
 - If the blade becomes twisted or misaligned in the cut, the teeth at the back edge of the blade can dig into the top surface of the wood causing the blade to climb out of the kerf and jump back toward the operator.
 - Kickback is the result of saw misuse and/or incorrect operating procedures or conditions and can be avoided by taking proper precautions as given below:
- a. **Maintain a firm grip with both hands on the saw and position your arms to resist kickback forces.** Position your body to either side of the blade, but not in line with the blade. *Kickback could cause the saw to jump backwards, but kickback forces can be controlled by the operator, if proper precautions are taken.*
- b. **When blade is binding, or when interrupting a cut for any reason, release the trigger and hold the saw motionless in the material until the blade comes to a complete stop.** Never attempt to remove the saw from the work or pull the saw backward while the blade is in motion or kickback may occur. *Investigate and take corrective actions to eliminate the cause of blade binding.*
- c. **When restarting a saw in the workpiece, center the saw blade in the kerf and check that saw teeth are not engaged into the material.** *If saw blade is binding, it may walk up or kickback from the workpiece as the saw is restarted.*
- d. **Support large panels to minimize the risk of blade pinching and kickback.** *Large panels tend to sag under their own weight. Supports must be placed under the panel on both sides, near the line of cut and near the edge of the panel.*
- e. **Do not use dull or damaged blades.** *Unsharpened or improperly set blades produce narrow kerf causing excessive friction, blade binding and kickback.*
- f. **Blade depth and bevel adjusting locking levers must be tight and secure before making cut.** *If blade adjustment shifts while cutting, it may cause binding and kickback.*
- g. **Use extra caution when making a "plunge cut" into existing walls or other blind areas.** *The protruding blade may cut objects that can cause kickback.*
10. **Check lower guard for proper closing before each use.** Do not operate the saw if lower guard does not move freely and close instantly. Never clamp or tie the lower guard into the open position. *If saw is accidentally dropped, lower guard may be bent. Raise the lower guard with the retracting handle and make sure it moves freely and does not touch the blade or any other part, in all angles and depths of cut.*
11. **Check the operation of the lower guard spring.** If the guard and the spring are not operating properly, they must be serviced before use. *Lower guard may operate sluggishly due to damaged parts, gummy deposits, or a build-up of debris.*

Circular Saw Safety Warnings (continued)

- SAFETY**
12. **Lower guard should be retracted manually only for special cuts such as "plunge cuts" and "compound cuts."** Raise lower guard by retracting handle and as soon as blade enters the material, the lower guard must be released. *For all other sawing, the lower guard should operate automatically.*
13. **Always observe that the lower guard is covering the blade before placing saw down on bench or floor.** *An unprotected, coasting blade will cause the saw to walk backwards, cutting whatever is in its path. Be aware of the time it takes for the blade to stop after switch is released.*
- SETUP**
14. **DO NOT USE THIS SAW WITH THE SAW HELD UPSIDE DOWN IN A VISE.**
The saw is not designed for such use and cannot be used safely in that position.
15. **Do not use to cut logs, tree limbs, or uneven lumber.**
16. **Wet lumber, green (unseasoned) lumber, and pressure treated lumber all have an increased potential for kickback and should only be cut with a blade for cutting that lumber type.** Wear a NIOSH-approved respirator and have appropriate ventilation whenever cutting pressure treated lumber.
- OPERATION**
17. **Do not use blades made from high-speed steel, abrasive blades, metal-cutting blades or masonry-cutting blades.** The guards of this saw are not designed to protect against the failure of such blades.
18. **Place the larger portion of the saw base on the larger, supported part of the workpiece.**
This will help maintain balance and control while the cut is completed.
19. **Blades must be rated to at least the maximum speed marked on the tool.**
20. **Maintain labels and nameplates on the tool.**
These carry important safety information. If unreadable or missing, contact Harbor Freight Tools for a replacement.
21. **Avoid unintentional starting.**
Prepare to begin work before turning on the tool.
22. **Do not lay the tool down until it has come to a complete stop.** Moving parts can grab the surface and pull the tool out of your control.
23. **When using a handheld power tool, maintain a firm grip on the tool with both hands to resist starting torque.**
24. **Do not leave the tool unattended when it is plugged into an electrical outlet.** Turn off the tool, and unplug it from its electrical outlet before leaving.
25. **Use clamps (not included) or other practical ways to secure and support the workpiece to a stable platform.** Holding the work by hand or against your body is unstable and may lead to loss of control.
26. **This product is not a toy.**
Keep it out of reach of children.
27. **Verify that there are no utility lines or hardware in or near the workpiece.**
This is especially critical for plunge cuts.
28. **Do not depress the spindle lock when starting or during operation.**
29. **People with pacemakers should consult their physician(s) before use.** Electromagnetic fields in close proximity to heart pacemaker could cause pacemaker interference or pacemaker failure. In addition, people with pacemakers should:
- Avoid operating alone.
 - Do not use with Trigger locked on.
 - Properly maintain and inspect to avoid electrical shock.
 - Any power cord must be properly grounded. Ground Fault Circuit Interrupter (GFCI) should also be implemented – it prevents sustained electrical shock.
30. **WARNING: Some dust created by power sanding, sawing, grinding, drilling, and other construction activities, contains chemicals known [to the State of California] to cause cancer, birth defects or other reproductive harm.**
Some examples of these chemicals are:
- Lead from lead-based paints
 - Crystalline silica from bricks and cement or other masonry products
 - Arsenic and chromium from chemically treated lumber
- Your risk from these exposures varies, depending on how often you do this type of work. To reduce your exposure to these chemicals: work in a well ventilated area, and work with approved safety equipment, such as those dust masks that are specially designed to filter out microscopic particles. (California Health & Safety Code § 25249.5, *et seq.*)
31. **WARNING: Handling the cord on this product will expose you to lead, a chemical known to the State of California to cause cancer, and birth defects or other reproductive harm. Wash hands after handling.** (California Health & Safety Code § 25249.5, *et seq.*)
32. **The warnings, precautions, and instructions discussed in this instruction manual cannot cover all possible conditions and situations that may occur.** It must be understood by the operator that common sense and caution are factors which cannot be built into this product, but must be supplied by the operator.

Vibration Safety

This tool vibrates during use.

Repeated or long-term exposure to vibration may cause temporary or permanent physical injury, particularly to the hands, arms and shoulders. To reduce the risk of vibration-related injury:

1. **Anyone using vibrating tools regularly or for an extended period should first be examined by a doctor and then have regular medical check-ups to ensure medical problems are not being caused or worsened from use.** Pregnant women or people who have impaired blood circulation to the hand, past hand injuries, nervous system disorders, diabetes, or Raynaud's Disease should not use this tool. If you feel any symptoms related to vibration (such as tingling, numbness, and white or blue fingers), seek medical advice as soon as possible.
2. **Do not smoke during use.** Nicotine reduces the blood supply to the hands and fingers, increasing the risk of vibration-related injury.
3. **Wear suitable gloves to reduce the vibration effects on the user.**
4. **Use tools with the lowest vibration when there is a choice.**
5. **Include vibration-free periods each day of work.**
6. **Grip tool as lightly as possible (while still keeping safe control of it). Let the tool do the work.**
7. **To reduce vibration, maintain the tool as explained in this manual.** If any abnormal vibration occurs, stop use immediately.



SAVE THESE INSTRUCTIONS.

!WARNING



TO PREVENT ELECTRIC SHOCK AND DEATH FROM INCORRECT GROUNDING WIRE CONNECTION:

Check with a qualified electrician if you are in doubt as to whether the outlet is properly grounded. Do not modify the power cord plug provided with the tool. Never remove the grounding prong from the plug. Do not use the tool if the power cord or plug is damaged. If damaged, have it repaired by a service facility before use. If the plug will not fit the outlet, have a proper outlet installed by a qualified electrician.

Grounded Tools: Tools with Three Prong Plugs

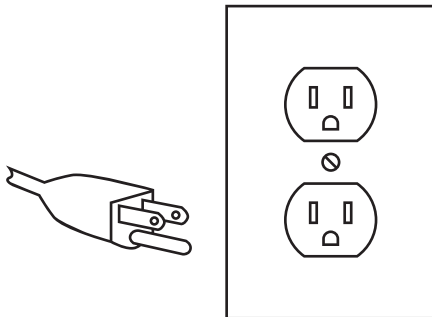

3-Prong Plug and Outlet

1. Tools marked with "Grounding Required" have a three wire cord and three prong grounding plug. The plug must be connected to a properly grounded outlet. If the tool should electrically malfunction or break down, grounding provides a low resistance path to carry electricity away from the user, reducing the risk of electric shock. **(See 3-Prong Plug and Outlet.)**

2. The grounding prong in the plug is connected through the green wire inside the cord to the grounding system in the tool. The green wire in the cord must be the only wire connected to the tool's grounding system and must never be attached to an electrically "live" terminal. **(See 3-Prong Plug and Outlet.)**
3. The tool must be plugged into an appropriate outlet, properly installed and grounded in accordance with all codes and ordinances. The plug and outlet should look like those in the preceding illustration. **(See 3-Prong Plug and Outlet.)**

Double Insulated Tools: Tools with Two Prong Plugs

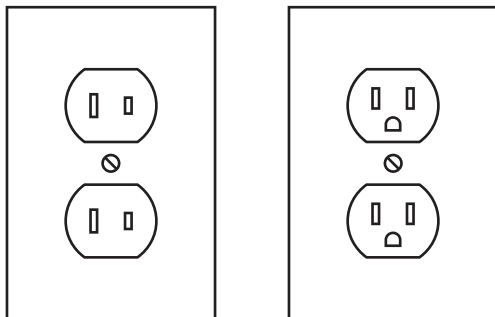

Outlets for 2-Prong Plug

1. Tools marked "Double Insulated" do not require grounding. They have a special double insulation system which satisfies OSHA requirements and complies with the applicable standards of Underwriters Laboratories, Inc., the Canadian Standard Association, and the National Electrical Code.
2. Double insulated tools may be used in either of the 120 volt outlets shown in the preceding illustration. **(See Outlets for 2-Prong Plug.)**

Extension Cords

1. **Grounded** tools require a three wire extension cord. **Double Insulated** tools can use either a two or three wire extension cord.
2. As the distance from the supply outlet increases, you must use a heavier gauge extension cord. Using extension cords with inadequately sized wire causes a serious drop in voltage, resulting in loss of power and possible tool damage. (See Table A on page 9.)
3. The smaller the gauge number of the wire, the greater the capacity of the cord. For example, a 14 gauge cord can carry a higher current than a 16 gauge cord. (See Table A.)
4. When using more than one extension cord to make up the total length, make sure each cord contains at least the minimum wire size required. (See Table A.)
5. If you are using one extension cord for more than one tool, add the nameplate amperes and use the sum to determine the required minimum cord size. (See Table A.)
6. If you are using an extension cord outdoors, make sure it is marked with the suffix "W-A" ("W" in Canada) to indicate it is acceptable for outdoor use.

7. Make sure the extension cord is properly wired and in good electrical condition. Always replace a damaged extension cord or have it repaired by a qualified electrician before using it.
8. Protect the extension cords from sharp objects, excessive heat, and damp or wet areas.

TABLE A: RECOMMENDED MINIMUM WIRE GAUGE FOR EXTENSION CORDS* (120/240 VOLT)					
NAMEPLATE AMPERES (at full load)	EXTENSION CORD LENGTH				
	25'	50'	75'	100'	150'
0 – 2.0	18	18	18	18	16
2.1 – 3.4	18	18	18	16	14
3.5 – 5.0	18	18	16	14	12
5.1 – 7.0	18	16	14	12	12
7.1 – 12.0	18	14	12	10	-
12.1 – 16.0	14	12	10	-	-
16.1 – 20.0	12	10	-	-	-

* Based on limiting the line voltage drop to five volts at 150% of the rated amperes.

Symbology

	Double Insulated
	Canadian Standards Association
	Underwriters Laboratories, Inc.
V	Volts
~	Alternating Current
A	Amperes
n ₀ xxxx/min.	No Load Revolutions per Minute (RPM)

	WARNING marking concerning Risk of Eye Injury. Wear ANSI-approved safety goggles with side shields.
	Read the manual before set-up and/or use.
	WARNING marking concerning Risk of Hearing Loss. Wear hearing protection.
	WARNING marking concerning Risk of Fire. Do not cover ventilation ducts. Keep flammable objects away.
	WARNING marking concerning Risk of Electric Shock. Properly connect power cord to appropriate outlet.

CHICAGO ELECTRIC®
POWER TOOLS

Specifications

Electrical Rating	120V~ / 60Hz / 10 A
Motor No Load Speed	5500 RPM
Maximum Blade Diameter	7-1/4"
Arbor	5/8"
Depth of Cut	2-7/16" @ 90° 1-5/8" @ 45°
Bevel Capacity	0° to 45°



Intertek
4005982

Setup - Before Use:



Read the **ENTIRE IMPORTANT SAFETY INFORMATION** section at the beginning of this manual including all text under subheadings therein before set up or use of this product.

Note: For additional information regarding the parts listed in the following pages, refer to *Parts List and Diagram* on page 14.

Functions

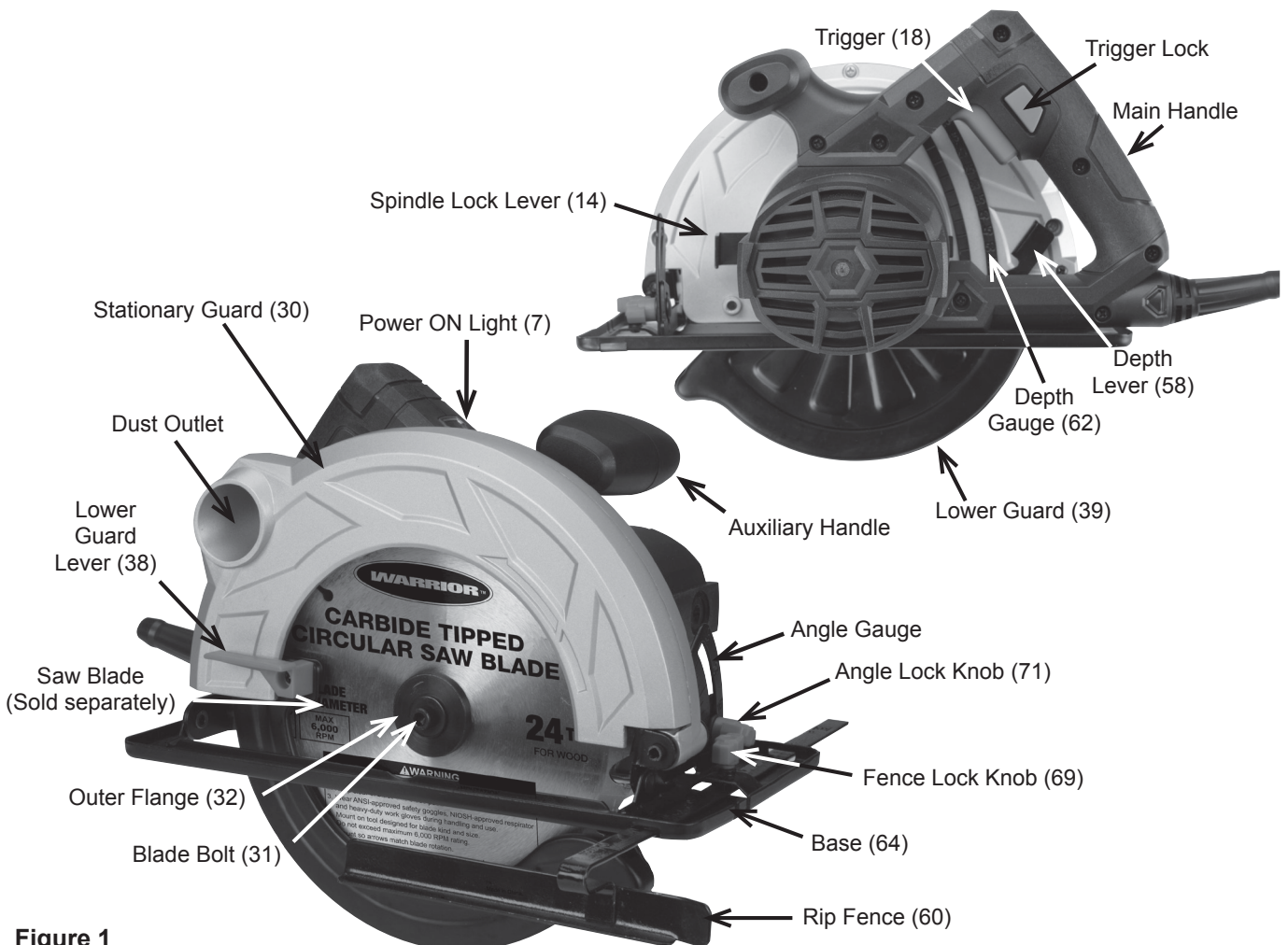

Figure 1

Operating Instructions



Read the **ENTIRE IMPORTANT SAFETY INFORMATION** section at the beginning of this manual including all text under subheadings therein before set up or use of this product.

Tool Set Up

WARNING

TO PREVENT SERIOUS INJURY FROM ACCIDENTAL OPERATION:
Release the Trigger and unplug the tool from its electrical outlet before adjusting tool or installing accessories.

To Remove/Install A Saw Blade (sold separately):

1. Lower the Base Plate to its lowest setting (See Depth Adjustment, following).
2. Depress the Spindle Lock Lever to hold the Saw Blade in place and unscrew (clockwise) and remove the Blade Clamp Bolt and Outer Flange.
3. Pull the Lower Guard all the way up into the Upper Guard. Remove the old Saw Blade and install a new Saw Blade onto the Spindle.
4. Slide the Outer Flange onto the Spindle with the cupped side towards the blade, and wrench tighten the Blade Bolt in place on the Spindle.

WARNING! Blade must be rated to at least 5,500 RPM.

Note: Make sure to install the new Saw Blade with its teeth and the arrow on the Saw Blade pointing in the same direction as the arrow on the Lower Guard.

Depth Adjustment

1. Loosen the Depth Lever.
2. Hold the Base down with one hand and raise or lower the body of the Saw with the other hand until the Blade is at the desired Depth of cut, using the Depth Gauge as a guide.
3. Tighten in place with the Depth Lever.

WARNING! To reduce the risk of Serious Injury:
Depth of cut must be adjusted to just clear the workpiece.

Angle Adjustment

1. Loosen the Angle Lock Knob.
2. Adjust the Base to the desired angle between 0° and 45°, using the Angle Gauge as a guide.
3. Tighten in place with the Angle Lock Knob.

TO PREVENT SERIOUS INJURY FROM FLYING FRAGMENTS:

Do not use blades made from high-speed steel, abrasive blades, or metal- or masonry-cutting blades. The guards of this saw are not designed to protect against the failure of such blades.

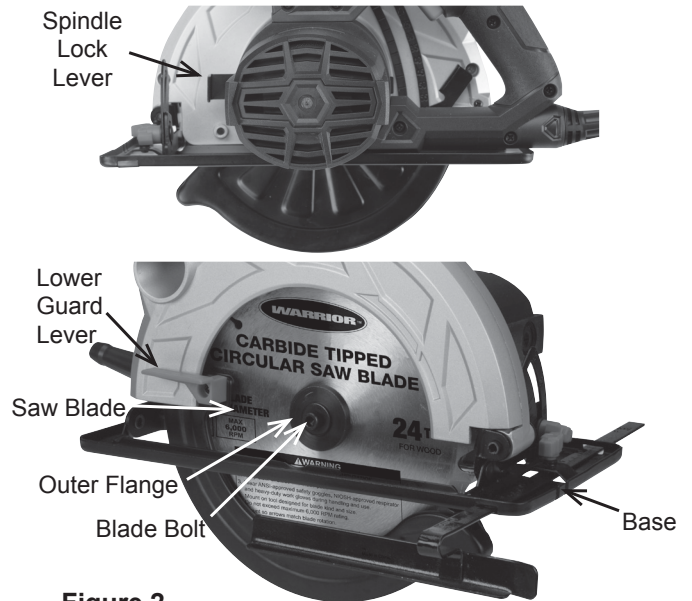

Figure 2

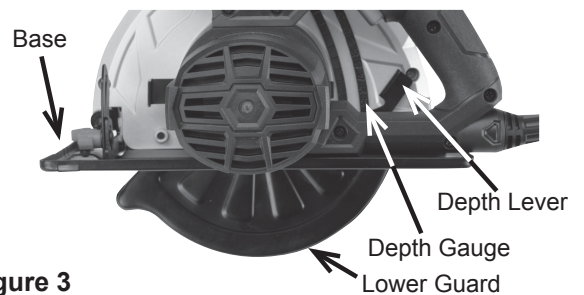

Figure 3

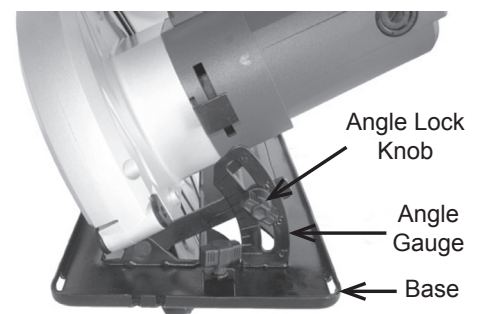

Figure 4

Fence Adjustment

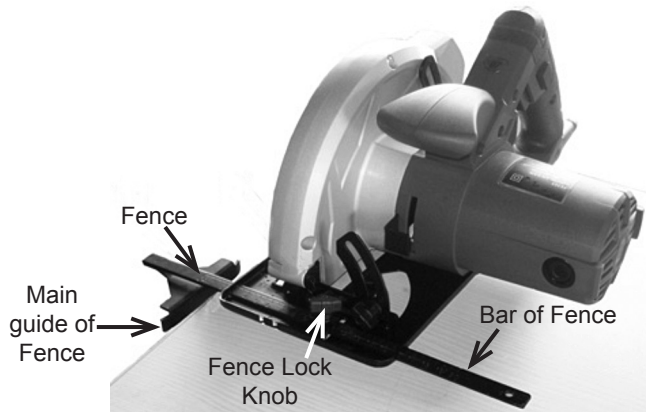

Figure 5

1. Loosen the Fence Lock Knob.
2. With the main guide of the Fence facing downward, slide the bar of the Fence into the slots on the Base until it is the desired distance from the Blade.
3. Tighten in place with the Fence Lock Knob.

Dust Collector

Connect a Dust collection system (sold separately) to the Dust Chute on the Stationary Guard.

Work Piece and Work Area Set Up

1. Work piece selection:
 - a. Work piece must be free of foreign objects and loose knots.
 - b. Do not use to cut logs, tree limbs, or uneven lumber.
 - c. Wet lumber, green (unseasoned) lumber, and pressure treated lumber all have an increased potential for kickback and should only be cut with a blade designed for cutting that lumber. Wear a NIOSH-approved respirator and have appropriate ventilation whenever cutting pressure treated lumber.
2. Designate a work area that is clean and well-lit. The work area must not allow access by children or pets to prevent distraction and injury.
3. Route the power cord along a safe route to reach the work area without creating a tripping hazard or exposing the power cord to possible damage. The power cord must reach the work area with enough extra length to allow free movement while working.
4. Secure loose workpieces using a vise or clamps (not included) to prevent movement while working.
5. Verify that there are no utility lines or hardware in or near the workpiece. This is especially critical for plunge cuts.

General Operating Instructions

1. Make all necessary depth and angle adjustments to the Circular Saw.
2. Make sure that all guards are in place in proper working order and that all adjustment knobs are tight before operation.
3. Plug the Power Cord into the nearest 120 volt, grounded, electrical outlet.
4. Firmly grip the Handle with one hand and the Auxiliary Handle with the other hand. Squeeze and hold the Trigger Lock, then the Trigger to turn on the Circular Saw.
5. Release the Trigger Lock.
6. Allow the Saw Blade to reach full speed before feeding the Saw Blade into the workpiece.
7. Make straight cuts only. Do not attempt to twist the Circular Saw to the right or left while cutting. If this occurs, the Saw Blade will "bind" in the workpiece causing kickback, potential injury, and/or damage to the workpiece and Circular Saw.
8. Do not force the Circular Saw to cut faster than it is designed to cut. Feed the Saw Blade gradually into the workpiece.
9. Turn off the Circular Saw if the Saw Blade is to be backed out of an uncompleted cut. When turning off the Circular Saw, allow the Saw Blade to fully stop on its own before removing the Circular Saw. Do not press against the Saw Blade to stop it.
10. Once the cutting job is completed, release the Trigger and wait until the Saw Blade stops spinning.
11. To prevent accidents, unplug the Power Cord from its electrical outlet. Clean, then store the tool indoors out of children's reach.

Maintenance and Servicing



Procedures not specifically explained in this manual must be performed only by a qualified technician.

⚠️ WARNING

TO PREVENT SERIOUS INJURY FROM ACCIDENTAL OPERATION:
Release the Trigger and unplug the tool from its electrical outlet before performing any inspection, maintenance, or cleaning procedures.

TO PREVENT SERIOUS INJURY FROM TOOL FAILURE:
Do not use damaged equipment. If abnormal noise or vibration occurs, have the problem corrected before further use.

Cleaning, Maintenance, and Lubrication

- BEFORE EACH USE**, inspect the general condition of the tool. Check for loose hardware, misalignment or binding of moving parts, cracked or broken parts, damaged electrical wiring, and any other condition that may affect its safe operation.
- AFTER USE**, wipe external surfaces of the tool with clean cloth.
- ⚠️ WARNING!** If the supply cord of this power tool is damaged, it must be replaced only by a qualified service technician.
- TO CLEAN:** The ventilation openings should be kept clean and free of dirt and debris. Wear ANSI-approved safety goggles and NIOSH-approved dust mask/respirator before cleaning ducts. The most effective way to clean the ventilation openings is with compressed air. The outer body may be cleaned with a clean cloth and a mild detergent. Do not use solvents. Do not immerse the Circular Saw in liquid.

Troubleshooting

Problem	Possible Causes	Likely Solutions
Tool will not start.	<ol style="list-style-type: none"> Cord not connected. No power at outlet. Tool's thermal reset breaker tripped (if equipped). Internal damage or wear. (Carbon brushes or switch, for example.) 	<ol style="list-style-type: none"> Check that cord is plugged in. Check power at outlet. If outlet is unpowered, turn off tool and check circuit breaker. If breaker is tripped, make sure circuit is right capacity for tool and circuit has no other loads. Turn off tool and allow to cool. Press reset button on tool. Have technician service tool.
Tool operates slowly.	Extension cord too long or cord diameter too small.	Eliminate use of extension cord. If an extension cord is needed, use one with the proper diameter for its length and load. See <i>Extension Cords</i> section on page 9.
Performance decreases over time.	<ol style="list-style-type: none"> Blade dull or damaged. Carbon brushes worn or damaged. 	<ol style="list-style-type: none"> Keep Blade sharp. Replace as needed. Have qualified technician replace brushes.
Excessive noise or rattling.	Internal damage or wear. (Carbon brushes or bearings, for example.)	Replace Carbon Brushes.
Overheating.	<ol style="list-style-type: none"> Forcing tool to work too fast. Accessory misaligned. Accessory dull or damaged. Blocked motor housing vents. Motor being strained by long or small diameter extension cord. 	<ol style="list-style-type: none"> Allow tool to work at its own rate. Check and correct accessory to fence and/or table alignment. Keep cutting accessories sharp. Replace as needed. Wear ANSI-approved safety goggles and NIOSH-approved dust mask/respirator while blowing dust out of motor using compressed air. Eliminate use of extension cord. If an extension cord is needed, use one with the proper diameter for its length and load. See <i>Extension Cords</i> section on page 9.



Follow all safety precautions whenever diagnosing or servicing the tool. Disconnect power supply before service.

PLEASE READ THE FOLLOWING CAREFULLY

THE MANUFACTURER AND/OR DISTRIBUTOR HAS PROVIDED THE PARTS LIST AND ASSEMBLY DIAGRAM IN THIS MANUAL AS A REFERENCE TOOL ONLY. NEITHER THE MANUFACTURER OR DISTRIBUTOR MAKES ANY REPRESENTATION OR WARRANTY OF ANY KIND TO THE BUYER THAT HE OR SHE IS QUALIFIED TO MAKE ANY REPAIRS TO THE PRODUCT, OR THAT HE OR SHE IS QUALIFIED TO REPLACE ANY PARTS OF THE PRODUCT. IN FACT, THE MANUFACTURER AND/OR DISTRIBUTOR EXPRESSLY STATES THAT ALL REPAIRS AND PARTS REPLACEMENTS SHOULD BE UNDERTAKEN BY CERTIFIED AND LICENSED TECHNICIANS, AND NOT BY THE BUYER. THE BUYER ASSUMES ALL RISK AND LIABILITY ARISING OUT OF HIS OR HER REPAIRS TO THE ORIGINAL PRODUCT OR REPLACEMENT PARTS THERETO, OR ARISING OUT OF HIS OR HER INSTALLATION OF REPLACEMENT PARTS THERETO.

Parts List

Part	Description	Qty
1	Right Handle	1
2	Cable & Plug	1
3	Cable Sleeve	1
4	Cord Plate	1
5	Pan Head Screw st4.2x14	2
6	Indicator-Lamp	1
7	Power ON Light	1
8	Left Handle	1
9	Pan Head Screw st4.2x16	6
10	Pan Head Screw st4.2x22	1
11	Pan Head Screw st4.2x25	2
12	Bearing 6002-2Z	1
13	Self-Lock Spring	1
14	Spindle Lock Lever	1
15	Circlip For Shaft 12	2
16	Rotor	1
17	Pan Head Screw st4.8x65	2
18	Trigger	1
19	Air Baffle Plate	1
20	Stator	1
21	Spring	1
22	Cord Plate	2
23	Bearing 607-2Z	1
24	Bearing Sleeve 17#	1
25	Housing	1
26	Nameplate	1
27	Carbon Brush Holder	1
28	Carbon Brush Cover	1
29	Carbon Brush	1
30	Stationary Guard	1
31	Blade Bolt M6x16	1
32	Outer Flange	1
34	Inner Flange	1
35	Cross Screw M4x12	3
36	Lower Guard Plate	1
37	Pan Head Screw M4x12	1

Part	Description	Qty
38	Lower Guard Lever	1
39	Lower Guard	1
40	Guard Spring	1
41	Output Spindle	1
42	Key 3X10x3.7	1
43	Bearing 6001Z	1
44	Cross Screw M5x10	3
45	Front Cover	1
46	Gear Position Steel Sleeve	1
47	Gear	1
48	Wave Washer 12	1
49	Oil Bearing 14X8x8	1
50	Pan Head Screw st4.8x25	4
51	Nut m4	1
52	Gear Housing	1
53	Washer 4	3
54	Pan Head Screw M4x14	3
55	Pan Head Screw M4x22	1
56	Washer $\Phi 6 \times \phi 14 \times 1.5$	2
57	Nut M6	1
58	Depth Lever	1
59	Circlip For Shaft 10	1
60	Rip Fence	1
61	Hex Key	1
62	Depth Gauge	1
63	Rivet	2
64	Base	1
65	Pan Head Screw M6x18	1
66	Lower Guard Bumper	1
67	Carriage Bolt M6x14	1
68	Spring 6x40	1
69	Fence Lock Knob	1
70	Angle Plate	1
71	Angle Lock Knob	1
72	Carriage Bolt M6x12	1

Assembly Diagram

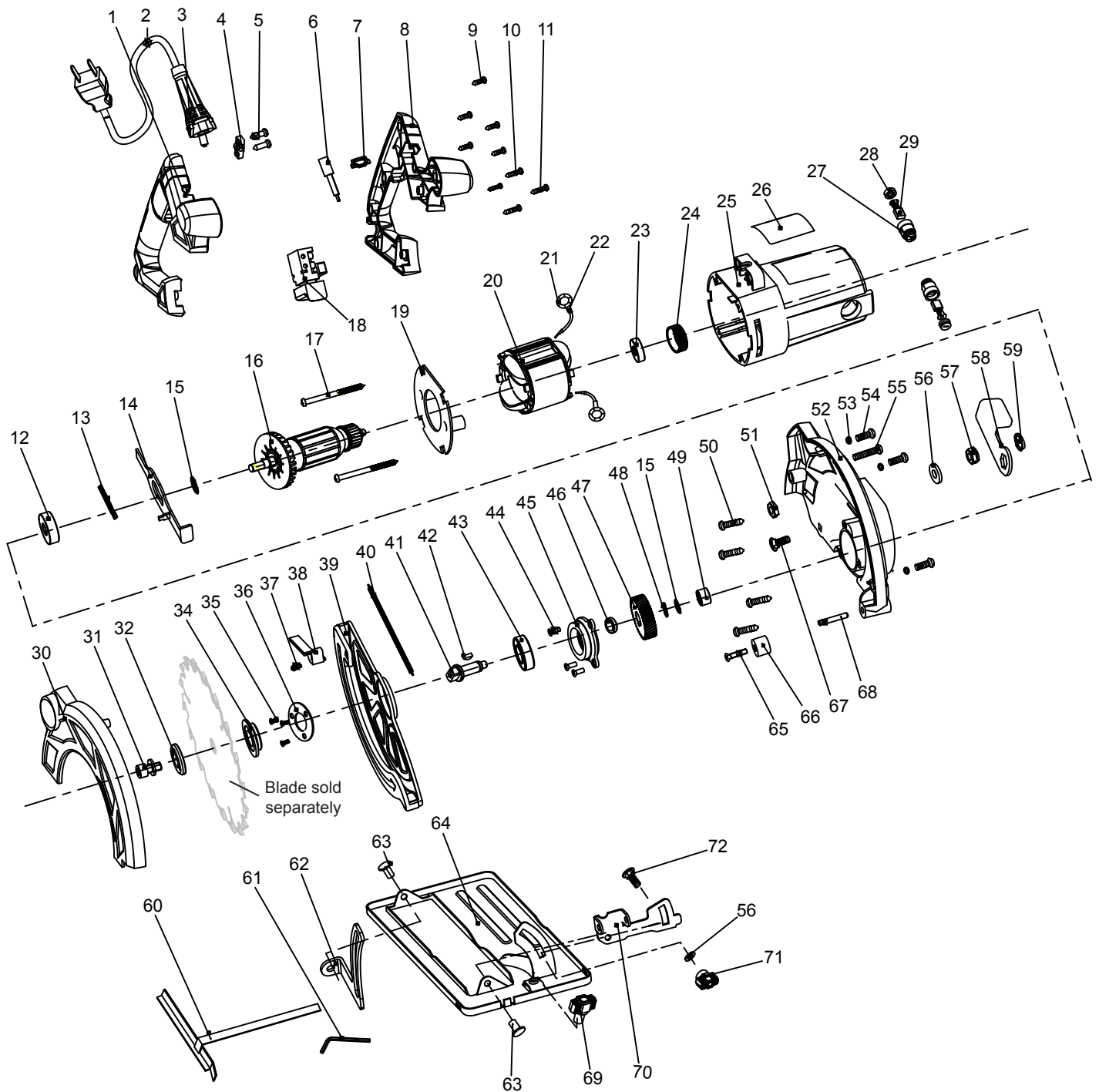

SAFETY

SETUP

OPERATION

MAINTENANCE

Record Product's Serial Number Here: _____

Note: If product has no serial number, record month and year of purchase instead.

Note: Some parts are listed and shown for illustration purposes only, and are not available individually as replacement parts.

Limited 90 Day Warranty

Harbor Freight Tools Co. makes every effort to assure that its products meet high quality and durability standards, and warrants to the original purchaser that this product is free from defects in materials and workmanship for the period of 90 days from the date of purchase. This warranty does not apply to damage due directly or indirectly, to misuse, abuse, negligence or accidents, repairs or alterations outside our facilities, criminal activity, improper installation, normal wear and tear, or to lack of maintenance. We shall in no event be liable for death, injuries to persons or property, or for incidental, contingent, special or consequential damages arising from the use of our product. Some states do not allow the exclusion or limitation of incidental or consequential damages, so the above limitation of exclusion may not apply to you. THIS WARRANTY IS EXPRESSLY IN LIEU OF ALL OTHER WARRANTIES, EXPRESS OR IMPLIED, INCLUDING THE WARRANTIES OF MERCHANTABILITY AND FITNESS.

To take advantage of this warranty, the product or part must be returned to us with transportation charges prepaid. Proof of purchase date and an explanation of the complaint must accompany the merchandise. If our inspection verifies the defect, we will either repair or replace the product at our election or we may elect to refund the purchase price if we cannot readily and quickly provide you with a replacement. We will return repaired products at our expense, but if we determine there is no defect, or that the defect resulted from causes not within the scope of our warranty, then you must bear the cost of returning the product.

This warranty gives you specific legal rights and you may also have other rights which vary from state to state.

CHICAGO  ELECTRIC®
POWER TOOLS

3491 Mission Oaks Blvd. • PO Box 6009 • Camarillo, CA 93011 • (800) 444-3353