

Owner's Manual & Safety Instructions

Save This Manual Keep this manual for the safety warnings and precautions, assembly, operating, inspection, maintenance and cleaning procedures. Write the product's serial number in the back of the manual near the assembly diagram (or month and year of purchase if product has no number). Keep this manual and the receipt in a safe and dry place for future reference.

REV 15a

CENTRALPNEUMATIC®

8GAL oil lubricated air compressor



Visit our website at: <http://www.harborfreight.com>
Email our technical support at: productsupport@harborfreight.com

ITEM 68740

When unpacking, make sure that the product is intact and undamaged. If any parts are missing or broken, please call 1-888-866-5797 as soon as possible.

Copyright© 2011 by Harbor Freight Tools®. All rights reserved.
No portion of this manual or any artwork contained herein may be reproduced in any shape or form without the express written consent of Harbor Freight Tools. Diagrams within this manual may not be drawn proportionally. Due to continuing improvements, actual product may differ slightly from the product described herein.
Tools required for assembly and service may not be included.

⚠WARNING

**Read this material before using this product.
Failure to do so can result in serious injury.
SAVE THIS MANUAL.**

Contents

IMPORTANT SAFETY INFORMATION	3
GENERAL COMPRESSOR SAFETY WARNINGS.....	3
AIR COMPRESSOR SAFETY WARNINGS	5
GROUNDING	6
110-120 VAC GROUNDED COMPRESSORS: COMPRESSORS WITH THREE PRONG PLUGS.....	6
SYMBOLOLOGY.....	7
SPECIFICATIONS.....	8
UNPACKING	8
INSTRUCTIONS FOR PUTTING INTO USE	8
FUNCTIONS	8
WORK PIECE AND WORK AREA SET UP	9
ASSEMBLY/MOUNTING.....	9
CHECKING THE OIL.....	10
GENERAL OPERATING INSTRUCTIONS	11
EMERGENCY DEPRESSURIZATION	12
AUTOMATIC SHUT OFF SYSTEM	12
MAINTENANCE AND SERVICING.....	13
CLEANING, MAINTENANCE, AND LUBRICATION	13
MAINTENANCE SCHEDULE.....	13
OIL MAINTENANCE.....	14
DRAINING MOISTURE FROM THE TANK.....	14
AIR FILTER MAINTENANCE	14
TROUBLESHOOTING	15
PARTS LIST	17
ASSEMBLY DIAGRAM.....	18
LIMITED 1 YEAR / 90 DAY WARRANTY	19

Important Safety Information

In this manual, on the labeling, and all other information provided with this product:



This is the safety alert symbol. It is used to alert you to potential personal injury hazards. Obey all safety messages that follow this symbol to avoid possible injury or death.

DANGER

DANGER indicates a hazardous situation which, if not avoided, will result in death or serious injury.

WARNING

WARNING indicates a hazardous situation which, if not avoided, could result in death or serious injury.

CAUTION

CAUTION, used with the safety alert symbol, indicates a hazardous situation which, if not avoided, could result in minor or moderate injury.

NOTICE

NOTICE is used to address practices not related to personal injury.

CAUTION

CAUTION, without the safety alert symbol, is used to address practices not related to personal injury.

General Compressor Safety Warnings



WARNING Read all safety warnings and instructions. *Failure to follow the warnings and instructions may result in electric shock, fire and/or serious injury.*

Save all warnings and instructions for future reference.

1. Work area safety

- Keep work area clean and well lit.** Cluttered or dark areas invite accidents.
- Do not operate the Compressor in explosive atmospheres, such as in the presence of flammable liquids, gases or dust.** Compressor motors produce sparks which may ignite the dust or fumes.
- Keep children and bystanders away from an operating compressor.**

2. Electrical safety

- Compressor plugs must match the outlet. Never modify the plug in any way. Do not use any adapter plugs with a grounded compressor.**

Standard plugs and matching outlets will reduce risk of electric shock.

- Do not expose the compressor to rain or wet conditions.** Water entering a compressor will increase the risk of electric shock.
- Do not abuse the cord. Never use the cord for pulling or unplugging the compressor. Keep cord away from heat, oil, sharp edges or moving parts.** Damaged or entangled cords increase the risk of electric shock.

3. Personal safety

- Stay alert, watch what you are doing and use common sense when operating this compressor. Do not use this compressor while you are tired or under the influence of drugs, alcohol or medication.** A moment of inattention while operating a compressor may result in serious personal injury.
- Use personal protective equipment. Always wear eye protection.** Safety equipment such as a dust mask, non-skid safety shoes, hard hat, or hearing protection used for appropriate conditions will reduce personal injuries.
- Prevent unintentional starting. Ensure the switch is in the off-position before connecting to power source or moving the compressor.**
- Only use safety equipment that has been approved by an appropriate standards agency.** Unapproved safety equipment may not provide adequate protection. Eye protection must be ANSI-approved and breathing protection must be NIOSH-approved for the specific hazards in the work area.

4. Compressor use and care

- Do not use the compressor if the switch does not turn it on and off.** Any compressor that cannot be controlled with the switch is dangerous and must be repaired.
- Disconnect the plug from the power source of the compressor before making any adjustments, changing accessories, or storing it.** Such preventive safety measures reduce the risk of starting the compressor accidentally.
- Store an idle compressor out of the reach of children and do not allow persons unfamiliar with the compressor or these instructions to operate it.** A compressor is dangerous in the hands of untrained users.
- Maintain the compressor. Keep the compressor clean for better and safer performance. Following instructions for lubricating and changing accessories. Keep dry, clean and free from oil and grease. Check for misalignment or binding of moving parts, breakage of parts and any other condition that may affect the compressor's operation. If damaged, have the compressor repaired before use.** Many accidents are caused by a poorly maintained compressor.
- Use the compressor in accordance with these instructions, taking into account the working**

conditions and the work to be performed. Use of the compressor for operations different from those intended could result in a hazardous situation.

5. **Service**

- a. **Have your compressor serviced by a qualified repair person using only identical replacement parts.** This will ensure that the safety of the compressor is maintained.

Air Compressor Safety Warnings

1. Risk of fire or explosion - Do not spray flammable liquid in a confined area or towards a hot surface. Spray area must be well-ventilated. Do not smoke while spraying or spray where spark or flame is present. Arcing parts - Keep compressor at least 20 feet away from explosive vapors, such as when spraying with a spray gun.
2. Risk of bursting - Do not adjust regulator higher than maximum stated pressure of attachment.
3. Risk of injury - Do not direct air stream at people or animals.
4. To reduce the risk of electric shock, do not expose to rain. Store indoors.
5. Wear ANSI-approved safety goggles during use.
6. Do not use to supply breathing air.
7. Do not use the air hose to move the compressor.
8. Drain Tank daily and after use. Internal rust causes tank failure and explosion.
9. Add correct amount of compressor oil before first use and every use. Operating with low or no oil causes permanent damage and voids warranty.
10. Do not remove the Pressure Switch (54) cover or adjust the internal components.
11. Do not use the air hose to move the compressor.
12. Compressor head gets hot during operation. Do not touch it or allow children nearby during or immediately following operation.
13. Release the pressure in the storage tank before moving.
14. The use of accessories or attachments not recommended by the manufacturer may result in a risk of injury to persons.
15. All air line components, including hoses, pipe, connectors, filters, etc., must be rated for a minimum working pressure of 150 PSI, or 150% of the maximum system pressure, whichever is greater.
16. **USE OF AN EXTENSION CORD IS NOT RECOMMENDED.** If you choose to use an extension cord, use the following guidelines:

RECOMMENDED MINIMUM WIRE GAUGE FOR EXTENSION CORDS (120 VOLT)				
NAMEPLATE AMPERES (at full load)	EXTENSION CORD LENGTH			
	25'	50'	100'	150'
0 – 6	18	16	16	14
6.1 – 10	18	16	14	12
10.1 – 12	16	16	14	12
12.1 – 16	14	12	Do not use.	
TABLE A				

- a. Make sure your extension cord is in good condition.
- b. Be sure to use an extension cord which is heavy enough to carry the current your product will draw. An undersized cord will cause a drop in line voltage resulting in loss of power and overheating. Table A shows the correct size to use depending on cord length and nameplate ampere rating. If in doubt, use the next heavier gauge. The smaller the gauge number, the heavier the cord.
17. Industrial applications must follow OSHA guidelines.
18. Maintain labels and nameplates on the compressor. These carry important safety information. If unreadable or missing, contact Harbor Freight Tools for a replacement.
19. This product is not a toy. Keep it out of reach of children.
20. Operate unit on level surface. Check oil level daily and fill to marked level if needed.
21. People with pacemakers should consult their physician(s) before use. Electromagnetic fields in close proximity to heart pacemaker could cause pacemaker interference or pacemaker failure.
22. **WARNING:** The brass components of this product contain lead, a chemical known to the State of California to cause cancer and birth defects or other reproductive harm. (California Health & Safety Code § 25249.5, *et seq.*)
23. **WARNING:** The cord of this product contains lead and/or di (2-ethylhexyl) phthalate (DEHP), chemicals known to the State of California to cause cancer, and birth defects or other reproductive harm. Wash hands after handling. (California Health & Safety Code § 25249.5, *et seq.*)
24. The warnings, precautions, and instructions discussed in this instruction manual cannot cover all possible conditions and situations that may occur. It must be understood by the operator that common sense and caution are factors which cannot be built into this product, but must be supplied by the operator.



SAVE THESE INSTRUCTIONS.

Grounding

⚠️ WARNING TO PREVENT ELECTRIC SHOCK AND DEATH FROM INCORRECT GROUNDING WIRE CONNECTION:

Check with a qualified electrician if you are in doubt as to whether the outlet is properly grounded. Do not modify the power cord plug provided with the compressor. Never remove the grounding prong from the plug. Do not use the compressor if the power cord or plug is damaged. If damaged, have it repaired by a service facility before use. If the plug will not fit the outlet, have a proper outlet installed by a qualified electrician.



110-120 VAC Grounded Compressors: Compressors with Three Prong Plugs

1. In the event of a malfunction or breakdown, grounding provides a path of least resistance for electric current to reduce the risk of electric shock. This compressor is equipped with an electric cord having an equipment-grounding conductor and a grounding plug. The plug must be plugged into a matching outlet that is properly installed and grounded in accordance with all local codes and ordinances.
2. Do not modify the plug provided – if it will not fit the outlet, have the proper outlet installed by a qualified electrician.
3. Improper connection of the equipment-grounding conductor can result in a risk of electric shock. The conductor with insulation having an outer surface that is green with or without yellow stripes is the equipment-grounding conductor. If repair or replacement of the electric cord or plug is necessary, do not connect the equipment-grounding conductor to a live terminal.
4. Check with a qualified electrician or service personnel if the grounding instructions are not completely understood, or if in doubt as to whether the compressor is properly grounded.
5. Use only 3-wire extension cords that have 3-prong grounding plugs and 3-pole receptacles that accept the compressor's plug.

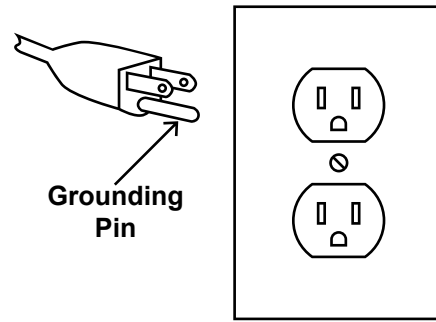

6. Repair or replace damaged or worn cord immediately.



120 VAC 3-Prong Plug and Outlet
(for up to 120 VAC and up to 15.5 A)

7. This compressor is intended for use on a circuit that has an outlet that looks like the one illustrated above in **120 VAC 3-Prong Plug and Outlet**. The compressor has a grounding plug that looks like the plug illustrated above in **120 VAC 3-Prong Plug and Outlet**.
8. The outlet must be properly installed and grounded in accordance with all codes and ordinances.
9. Do not use an adapter to connect this compressor to a different outlet.

Symbology

	Double Insulated
	Canadian Standards Association
	Underwriters Laboratories, Inc.
VAC	Volts Alternating Current
A	Amperes
n_0 xxxx/min.	No Load Revolutions per Minute (RPM)

Specifications

Electrical Requirements	120 VAC / 60 Hz / 2 HP
Amperage	14A (Dedicated circuit recommended)
Air Outlet Size	1/4"-18 NPT
Air Pressure	Auto Shut-Off @ 125 PSI Restart @ 95 PSI
Air Tank Capacity	8 Gallons
Air Flow Capacity	4.5 SCFM @ 90 PSI 5.5 SCFM @ 40 PSI
Oil Capacity	5.6 oz.
Oil Type	SAE 30W non-detergent Air Compressor Oil (Sold separately)
Decibel Level	88 dB @ 1m



Instructions for putting into use



Read the **ENTIRE IMPORTANT SAFETY INFORMATION** section at the beginning of this manual including all text under subheadings therein before set up or use of this product.

WARNING

TO PREVENT SERIOUS INJURY FROM ACCIDENTAL

OPERATION:

Turn the Power Lever "OFF" and unplug the Air Compressor from its electrical outlet before assembling or making any adjustments to the compressor.

Note: For additional information regarding the parts listed in the following pages, refer to the Assembly Diagram near the end of this manual.

Functions

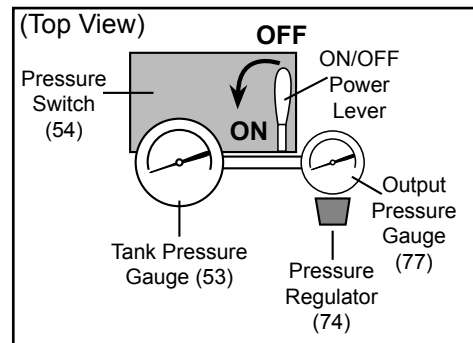
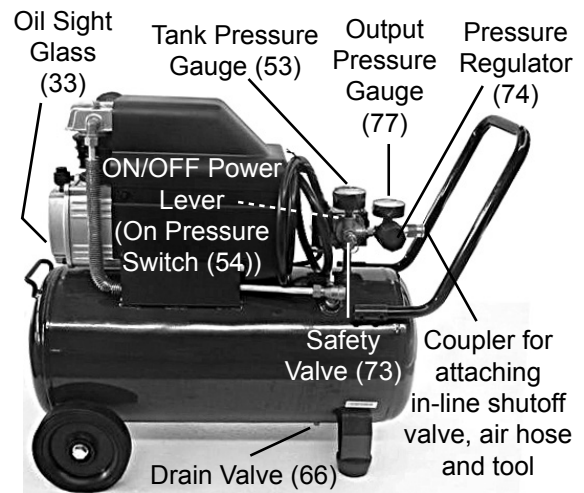

Figure 1

Work Piece and Work Area Set Up

1. Designate a work area that is clean and well-lit. The work area must not allow access by children or pets to prevent injury.
2. Locate the Compressor on a flat level surface to ensure proper pump lubrication and to prevent damage to the unit. Keep at least 12" of space around the unit to allow air circulation.
3. Route the power cord from the compressor to the grounded wall outlet, along a safe path without creating a tripping hazard or exposing the power cord to possible damage.

Assembly/Mounting

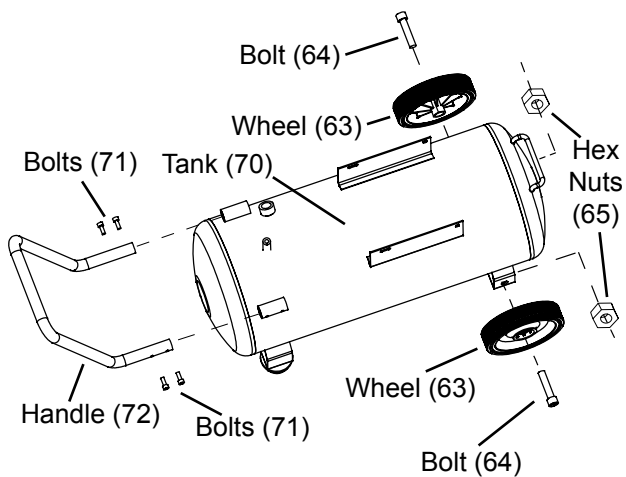

Figure 2

1. Attach the Wheels (63) to the Tank (70), using the Bolts (64) and Hex Nuts (65).
2. Slide the Handle (72) into the two slots on the top of the Tank and secure in place with four Bolts (71).

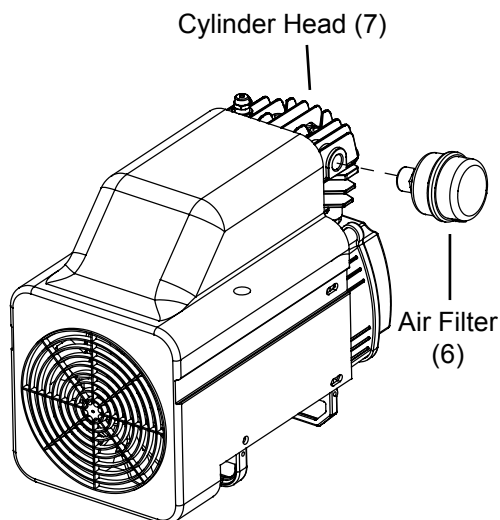

Figure 3

3. Thread the Air Filter (6) onto the side of the Cylinder Head (7).

4. Break in the new Air Compressor as follows:
 - a. Make sure the Power Lever is OFF and the unit is unplugged. Insert a male coupler (sold separately) into the female Quick Coupler (76) and fully open all regulators and valves.
 - b. Plug in the Power Cord.
 - c. Turn the Power Lever ON.
 - d. Let the unit run for 30 minutes. Air will expel freely through the Coupler.
 - e. Turn the Power Lever OFF.
 - f. Unplug the Power Cord and remove the male coupler.

5. Connect a regulator valve, an in-line shut off valve and a 1/4" NPT air hose to the Quick Coupler (76) (all sold separately). The air hose must be long enough to reach the work area with enough extra length to allow free movement while working.

Note: An in-line shutoff ball valve is an important safety device because it controls the air supply even if the air hose is ruptured. The shutoff valve should be a ball valve because it can be closed quickly.

6. Depending on the tool which you will be using with this compressor, you may need to incorporate additional components, such as an in-line oiler, a filter, or a dryer (all sold separately). Consult your air tool's manual for needed accessories. See typical Air Line Set up Charts on the following pages. This compressor is a portable type compressor.

Air Tool & Spray Gun Portable Setup

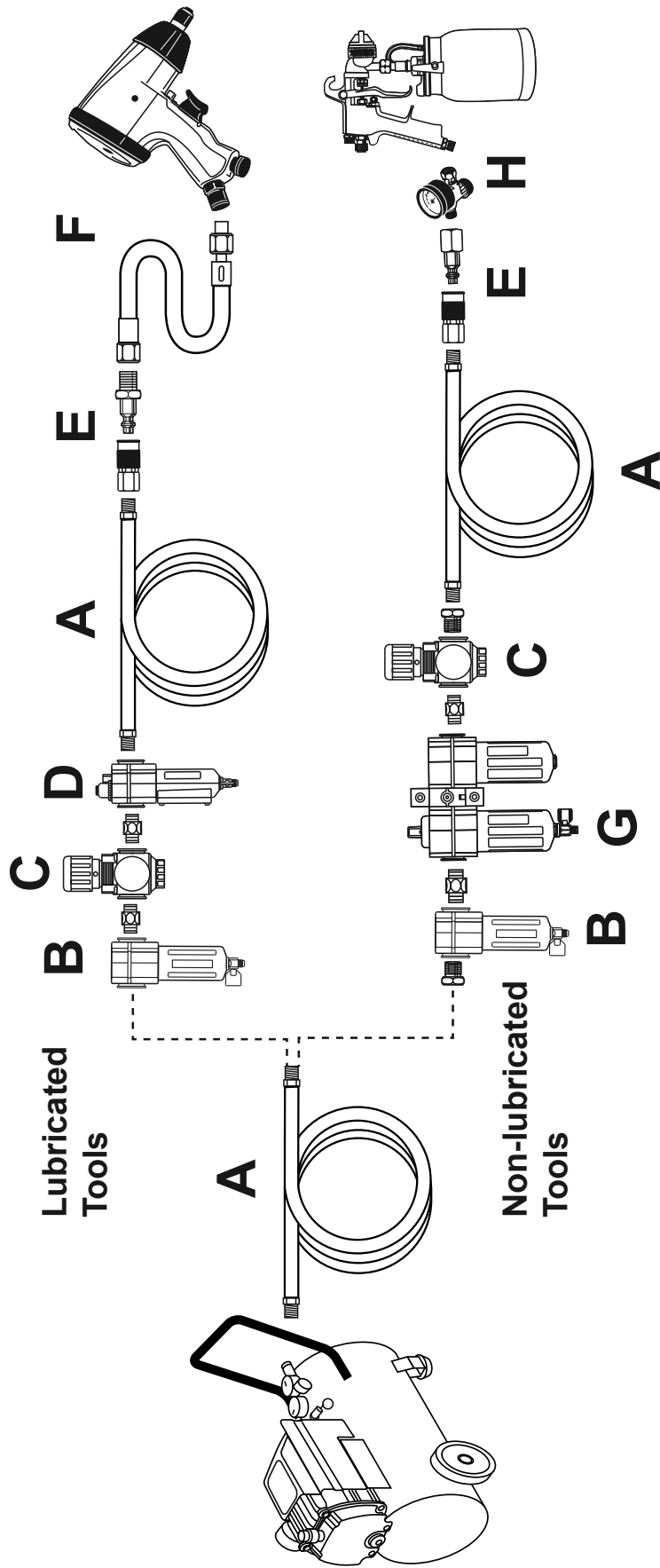

Description	Function
A Air Hose	Connects air to tool
B Filter	Prevents dirt and condensation from damaging tool or work piece
C Regulator	Adjusts air pressure to tool
D Lubricator (optional)	For air tool lubrication
E Coupler and Plug	Provides each connections
F Leader Hose (optional)	Increases coupler life
G Air Cleaner / Dryer (optional)	Prevents water vapor from damaging work piece
H Air Adjusting Valve (optional)	For fine tuning airflow at tool

Air Tool & Spray Gun Stationary Setup

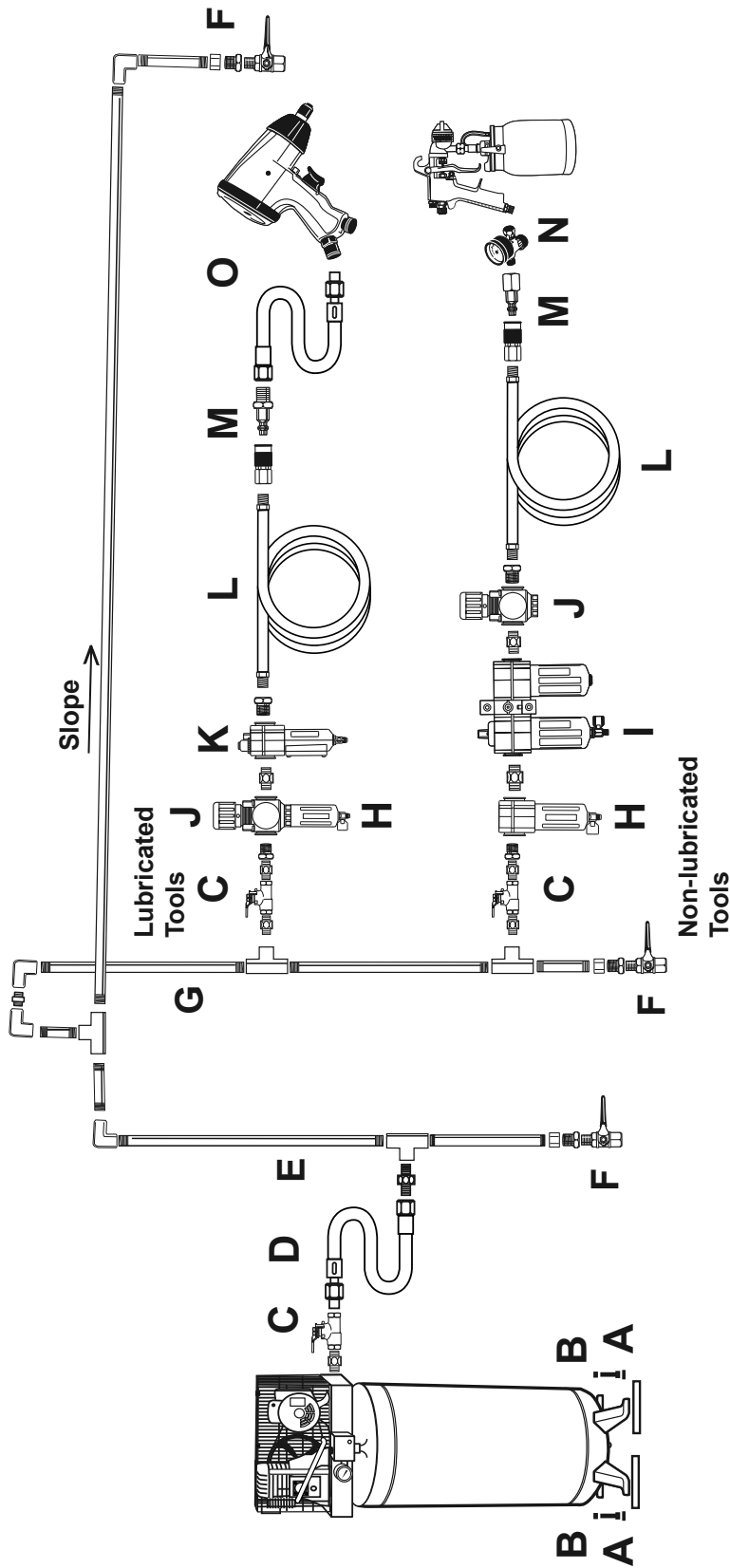

Description	Function
A Vibration Pads	For noise and vibration reduction
B Anchor Bolts	Secures air compressor in place
C Ball Valve	Isolates sections of system for maintenance
D Isolation Hose	For vibration reduction
E Main Air Line - 3/4" minimum recommended	Distributes air to branch lines
F Ball Valve	To drain moisture from system
G Branch Air Line - 1/2" minimum recommended	Brings air to point of use
H Filter	Prevents dirt and condensation from damaging tool or work piece
I Air Cleaner / Dryer (optional)	Prevents water vapor from damaging work piece
J Regulator	Adjusts air pressure to tool
K Lubricator	For air tool lubrication
L Air Hose	Connects air to tool
M Coupler and Plug	Provides each connections
N Air Adjusting Valve	For fine tuning airflow at tool
O Leader Hose	Increases coupler life

Checking the Oil

1. Check the oil level before operation. Fill the Pump Crankcase (39) with premium quality SAE 30-weight, non-detergent air compressor oil.

IMPORTANT: Running the Air Compressor with the incorrect amount of oil will cause damage to the equipment and void the warranty. To prevent damage, do not use with overfilled or low oil. Slowly fill to full line, wait 2 minutes and fill back up to full line. Compressor has small passages that will fill slowly.

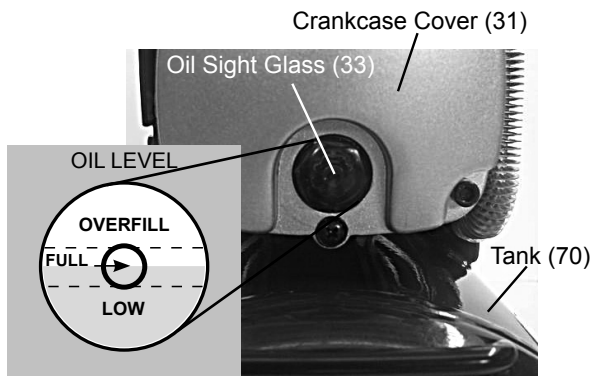

Figure 5

2. The oil level should be at the center of the “full” level on the oil level sight glass, as shown in Figure 5. Add oil as needed to maintain this level. Do not let the oil level go below the center dot (LOW as shown above) and do not overfill the oil so that it is above the center dot (OVERFILL as shown above) on the sight glass.

3. To add oil:
 - a. Remove the Oil Plug (37).
 - b. Using a funnel to avoid spills, pour enough oil into the Pump Crankcase (39) to reach the “full” level in the Oil Sight Glass (33).
 - c. Replace the Oil Plug.

Cold Weather Operation

Premium quality 30-weight, non-detergent air compressor oil (sold separately) is recommended for use with this compressor. Start compressor in heated area if outdoor temperatures drop below 32° F. If this is not practical, drain out the old pump oil and use SAE 10W Non-detergent Air Compressor Oil in the pump crankcase instead whenever the compressor’s temperature will fall below 40°. Do not use multi-viscosity oil (such as 10W-30), they leave carbon deposits on pump components and lead to accelerated failure. Heavy operation may require heavier viscosity oil.

4. If uncertain which oil to use for this compressor, please call Harbor Freight Tools customer service at 1-888-866-5797 for assistance.
5. **Change the compressor oil after the first hour of use to remove any debris.**

WARNING! To prevent serious injury from burns: Do not add or change the oil while the compressor is in operation. Allow the compressor to cool before replacing oil.

General Operating Instructions



Read the **ENTIRE IMPORTANT SAFETY INFORMATION** section at the beginning of this manual including all text under subheadings therein before set up or use of this product.

1. **IMPORTANT: First, turn the Power Switch OFF.** This releases tank pressure and allows the motor to start freely, without tripping the Circuit Breaker.
2. Close the Drain Valve (66).
3. Make sure all nuts and bolts are tight.
4. Check for oil leaks and check the oil level (See Checking the Oil).
5. Close the in-line Shutoff Valve between the compressor and the air hose.
6. Make sure the air tool's throttle or switch is in the off position.
7. Connect the air tool to the air hose.
8. Plug the Air Compressor Power Cord into a grounded 120 V electrical outlet.
9. Open the in-line Shutoff Valve.
10. Turn the Power Lever ON.
11. Allow the Air Compressor to build up pressure until it cycles off.

Note: At the beginning of the day's first use of the Air Compressor, check for air leaks by applying soapy water to connections while the Air Compressor is pumping and after pressure cut-out. Look for air bubbles. If air bubbles are present at connections, tighten connections. Do not use the air compressor unless all connections are air tight, the extra air leaking out will cause the compressor to operate too often, increasing wear on the compressor.

Note: As long as the Power Lever is ON, the operation of the Air Compressor is automatic, controlled by an internal pressure switch. The Compressor will turn on automatically when the air pressure drops to 95 PSI as indicated on the Tank Pressure Gauge (53), and will turn off automatically when the air pressure reaches 125 PSI as indicated. **IMPORTANT:** The internal pressure switch is not user adjustable, **do not make changes to the air pressure settings of the internal pressure switch.** Any change to the automatic pressure levels may cause excess pressure to accumulate, causing a hazardous situation.

12. Adjust the Air Compressor's Pressure Regulator (74) so that the air output is enough to properly power the tool, but the output will not exceed the tool's maximum air pressure at any time. Turn the knob clockwise to increase the pressure and counter-clockwise to decrease pressure. Adjust the pressure

gradually, while checking the air output gauge to set the pressure.

13. Use the air tool as needed.
14. After the job is complete, turn the Power Lever OFF.

Note: Turn the switch off before unplugging the compressor.

15. Unplug the Air Compressor.
16. Close the in-line Shutoff Valve.
17. Bleed air from the tool then disconnect the tool.
18. Turn the Drain Valve (66), at the bottom of the Tank, two turns to release any built-up moisture and the internal tank pressure. Close the valve after moisture has drained out. Do not remove the Drain Valve.
19. Clean, then store the Air Compressor indoors.

Emergency Depressurization

If it is necessary to quickly *depressurize* the Compressor, turn the Power Lever OFF. Then, pull on the ring on the Safety Valve (73) to quickly release stored air pressure.

Automatic Shut off System

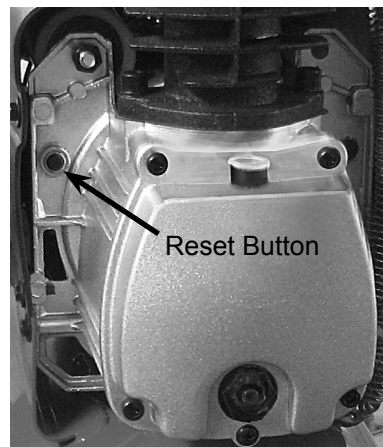

Figure 4

1. If the Compressor automatically shuts off:
 - a. Shut off all tools.
 - b. Wait until the Compressor cools down (about 10 minutes);
 - c. If the unit does not start up again on it's own, press the Reset Button to start the compressor;
 - d. Resume operation.
2. Possible causes of repeated automatic shut off of the compressor are:
 - a. Using an extension cord that is too long or narrow;
 - b. An air leak or open hose causing the compressor to cycle too often and build up heat.
3. Correct any issues before further use to avoid damage to the compressor.

Maintenance and Servicing



Procedures not specifically explained in this manual must be performed only by a qualified technician.

WARNING

TO PREVENT SERIOUS INJURY FROM ACCIDENTAL

OPERATION:

Turn the Power Lever “OFF” and unplug the Compressor from its electrical outlet before performing any inspection, maintenance, or cleaning procedures.

TO PREVENT SERIOUS INJURY FROM TOOL FAILURE:

Do not use damaged equipment. If abnormal noise or vibration occurs, have the problem corrected before further use.

Cleaning, Maintenance, and Lubrication

1. **BEFORE EACH USE**, inspect the general condition of the Air Compressor. Check for loose hardware, misalignment or binding of moving parts, cracked or broken parts, damaged electrical wiring, and any other condition that may affect its safe operation.
2. **AFTER USE**, wipe external surfaces of the tool with a clean cloth.
3. **WARNING!** If the supply cord of this power tool is damaged, it must be replaced only by a qualified service technician.

Maintenance Schedule

Following are general guidelines for maintenance checks of the Air Compressor.

Note: The environment in which the compressor is used, and the frequency of use can affect how often you will need to check the Air Compressor components and perform maintenance procedures.

Daily:

- a. Check oil level.
- b. Check for oil leaks.
- c. Make sure all nuts and bolts are tight.
- d. Drain moisture from air tank.
- e. Check for abnormal noise or vibration.
- f. Check for air leaks.*
- g. Wipe off any oil or dirt from the compressor.**

Weekly:

- a. Inspect Air Filter (6).
- b. Inspect Oil Plug (37).

Monthly:

Inspect Safety Valve (73).

Every 6 months or 100 Operation Hours:

Replace Pump oil.***

* To check for air leaks, apply soapy water to joints while the Air Compressor is pressurized. Look for air bubbles.

** To clean the compressor surface, wipe with a damp cloth, using a mild detergent or mild solvent.

*** Use Air Compressor Oil only (sold separately).

Oil Maintenance

Check oil periodically for clarity. Replace oil if it appears milky or if debris is present, or every 6 months, or 100 hours of runtime, whichever comes first. In harsh environments such as high heat or high humidity, you will need to replace the oil more frequently.

WARNING: Risk of personal injury hazard. Allow Air Compressor to cool before changing the oil.

To drain the oil from the Pump Crankcase (39):

- a. Place a container under the Drain Plug (35).
- b. Remove the Oil Plug (37) to allow air flow into the Pump.
- c. Remove the Drain Plug, allowing the oil to drain into the container.
- d. When the oil is completely drained from the Pump, replace the Drain Plug.
- e. Fill the Pump with new compressor oil to the FULL level on the Oil Sight Glass (33).
- f. Replace and tighten the Oil Plug.
- g. Discard the old oil according to local, state and federal regulations.

Draining Moisture from the Tank

The Drain Valve (66) is located under the Tank (70). It must be accessed daily to release all trapped air and moisture from the Tank. This will eliminate condensation which can cause tank corrosion.

Note: Do not open the Drain Valve so that more than four threads are showing.

To empty the air and condensation:

- a. Make sure the Power Lever of the compressor is off.
- b. Place a collection pan under the Drain Valve.
- c. Unthread the Drain Valve two or three turns ONLY.
- d. When all the pressure is released, close the Drain Valve.

Air Filter Maintenance

Check the Air Filter weekly to see if it needs replacement. If working in dirty environments, you may need to replace the filter more often. To replace the Air Filter:

- a. Remove the Cover (1).
- b. Remove the Air Filter (6).
- c. Replace with a new Air Filter.
- d. Replace the Cover.

Troubleshooting

Problem	Possible Causes	Likely Solutions
Compressor does not start or restart	<ol style="list-style-type: none"> 1. Incorrect power supply. 2. No power at outlet. 3. Power cord not plugged in properly. 4. Thermal overload switch tripped. 5. Building power supply circuit tripped or blown fuse. 6. Tanks are pressurized. 7. Cord wire size is too small or cord is too long to properly power compressor. 8. Compressor needs service. 	<ol style="list-style-type: none"> 1. Check that circuit matches compressor requirements. 2. Reset circuit breaker, or have outlet serviced by a qualified technician. 3. Check that cord is plugged in securely. 4. Turn off Tool. Turn off Compressor and wait for it to cool down. Press reset button. Resume operation. 5. Reset circuit or replace fuse. Check for low voltage conditions. It may be necessary to disconnect other electrical appliances from the circuit or move the compressor to its own circuit. 6. Fully bleed tanks of air. 7. Use larger diameter or shorter extension cord or eliminate extension cord. See Recommended Wire Gauge for Extension Cords in Safety section. 8. Have unit inspected by a qualified technician.
Compressor builds pressure too slowly	<ol style="list-style-type: none"> 1. Incorrect power supply. 2. Crankcase overfilled with oil or oil too thick. 3. Working environment too cold. 4. Safety valve needs service. 5. Loose fittings. 	<ol style="list-style-type: none"> 1. Check that circuit matches compressor requirements. 2. Drain oil and refill to proper level with recommended oil. 3. Move unit to a warmer location. Check that recommended oil is in crankcase. 4. Listen for air leaking from valve. If leaking replace with identical valve with same rating. 5. Reduce air pressure, then check all fittings with a soap solution for air leaks and tighten as needed. Do not overtighten.
Compressor not building enough air pressure	<ol style="list-style-type: none"> 1. Filters need cleaning/replacing. 2. Crankcase oil too thick. 3. Check Valve needs service. 4. Compressor not large enough for job. 5. Loose fittings. 6. Hose or hose connections not adequate. 7. High altitude reducing air output. 	<ol style="list-style-type: none"> 1. Check inlet and outlet filters. Clean and/or replace as needed. 2. Drain oil and refill to proper level with recommended oil. 3. Clean or replace, as needed. 4. Check if accessory SCFM is met by Compressor. If Compressor cannot supply enough air flow (SCFM), you need a larger Compressor. 5. Reduce air pressure, then check all fittings with a soap solution for air leaks and tighten as needed. Do not overtighten. 6. Replace with larger hose and/or hose connections. 7. You may need a larger compressor if you are situated in a high altitude location.
High Oil Consumption	<ol style="list-style-type: none"> 1. Crankcase oil too thin. 2. Unit not on level surface. 3. Crankcase vents clogged. 	<ol style="list-style-type: none"> 1. Drain oil and refill to proper level with recommended oil. 2. Reposition unit on a level surface. 3. Clean Crankcase vents.
 <p>Follow all safety precautions whenever diagnosing or servicing the compressor. Disconnect power supply before service.</p>		

Problem	Possible Causes	Likely Solutions
Overheating	<ol style="list-style-type: none"> 1. Filters need cleaning/replacing. 2. Crankcase oil too thin or incorrect type. 3. Crankcase oil level too low. 4. Unusually dusty environment. 5. Cord is too small of a gauge or too long to handle compressor. 6. Unit not on level surface. 	<ol style="list-style-type: none"> 1. Check inlet and outlet filters. Clean and/or replace as needed. 2. Drain oil and refill to proper level with recommended oil. 3. Add oil to proper level, check for leaks. 4. Clean and/or replace filters more often or move unit to cleaner environment. 5. Increase cord size or use shorter length extension cord, or eliminate extension cord. See Recommended Wire Gauge for Extension Cords in Safety section. 6. Reposition unit on a level surface.
Compressor starts and stops excessively	<ol style="list-style-type: none"> 1. Compressor not large enough for job. 2. Loose fittings. 	<ol style="list-style-type: none"> 1. Check if accessory SCFM is met by Compressor. If Compressor doesn't reach accessory SCFM, you need a larger Compressor. 2. Reduce air pressure, then check all fittings with a soap solution for air leaks and tighten as needed. Do not overtighten.
Excessive noise	<ol style="list-style-type: none"> 1. Crankcase overfilled with oil or oil is incorrect thickness or type. 2. Crankcase oil level too low. 3. Loose or damaged belt guard. 4. Loose fittings. 5. Unit not on level surface. 	<ol style="list-style-type: none"> 1. Drain oil and refill to proper level with recommended oil. 2. Add oil to proper level, check for leaks. 3. Replace belt guard. 4. Reduce air pressure, then check all fittings with a soap solution for air leaks and tighten as needed. Do not overtighten. 5. Reposition unit on a level surface.
Moisture in discharge air	Too much moisture in air.	Install inline air filter/dryer, and/or relocate to less humid environment.
Oil in discharge air	<ol style="list-style-type: none"> 1. Crankcase oil too thin or crankcase overfilled with oil. 2. Crankcase vents clogged. 	<ol style="list-style-type: none"> 1. Drain oil and refill to proper level with recommended oil. 2. Clean Crankcase vents.
Safety Valve "pops"	Safety valve needs service.	Pull on test ring of safety valve. If it still pops, replace.
Air leaks from pump or fittings	Loose fittings.	Reduce air pressure, then check all fittings with a soap solution for air leaks and tighten as needed. Do not overtighten.
Air leaks from tank	Defective or rusted tank.	Have tank replaced by a qualified technician.
 Follow all safety precautions whenever diagnosing or servicing the compressor. Disconnect power supply before service.		

Parts List

Part	Description	Qty
1	Cover	1
2	Elbow	1
3	Start Valve	1
4	Spring Washer M6	8
5	Screw M6 x 50	4
6	Air Filter	1
7	Cylinder Head	1
8	Head Gasket	1
9	Valve Plate	2
10	Metal Gasket	1
11	Valve	2
12	Valve Plate Gasket	1
13	Cylinder	1
14	Bolt M8 x 30	2
15	Spring Washer M8	3
16	Cylinder Gasket	1
17	Pin	1
18	Compression Ring	2
19	Oil Ring	1
20	Wrist Pin Retainer	2
21	Piston	1
22	Connecting Rod	1
23	Screw M6 x 20	5
24	Hex Nut M6	3
25	Crank Shaft	1
26	O-Ring	2
26a	Zip Tie	1
27	Capacitor	1
28	Screw M8 x 20	1
29	Capacitor Bracket	1
30	Hex Nut M8	1
31	Crank Case Cover	1
32	O-Ring	1
33	Oil Sight Glass	1
34	O-Ring	1
35	Drain Plug M5 x 10	1
36	O-Ring	1
37	Oil Plug	1
38	Crankcase Cover Gasket	1
39	Pump Crankcase	1
40	Washer M5	10

Part	Description	Qty
41	Screw M5 x 16	10
42	Manual Overload Protector	1
43	Oil Seal	1
44	Bearing	1
45	Rotator	1
46	Bearing	1
47	Stator	1
48	Automatic Thermal Protector	1
49	End Cover	1
50	Fan	1
51	Circlip	1
51a	Plain Washer 5	4
51b	Spring Washer 5	4
51c	Bolt	4
52	Connector	1
53	Tank Pressure Gauge	1
54	Pressure Switch	1
55	Unloader Tube	1
56	Nut	1
57	Ferrule	1
58	Check Valve	1
59	Ferrule	2
60	Nut	2
61	Exhaust Tube	1
62	Cooling Fin	1
63	Wheel	2
64	Bolt M12 x 55	2
65	Hex Nut M12	2
66	Drain Valve	1
67	Foot Pad	2
68	Washer	2
69	Screw M6 x 25	2
70	Tank	1
71	Bolt M6 x 10	4
72	Handle	1
73	Safety Valve	1
74	Pressure Regulator	1
75	Motor Cord	1
76	Quick Coupler	1
77	Output Pressure Gauge	1
78	Plug	1

ASSEMBLY DIAGRAM

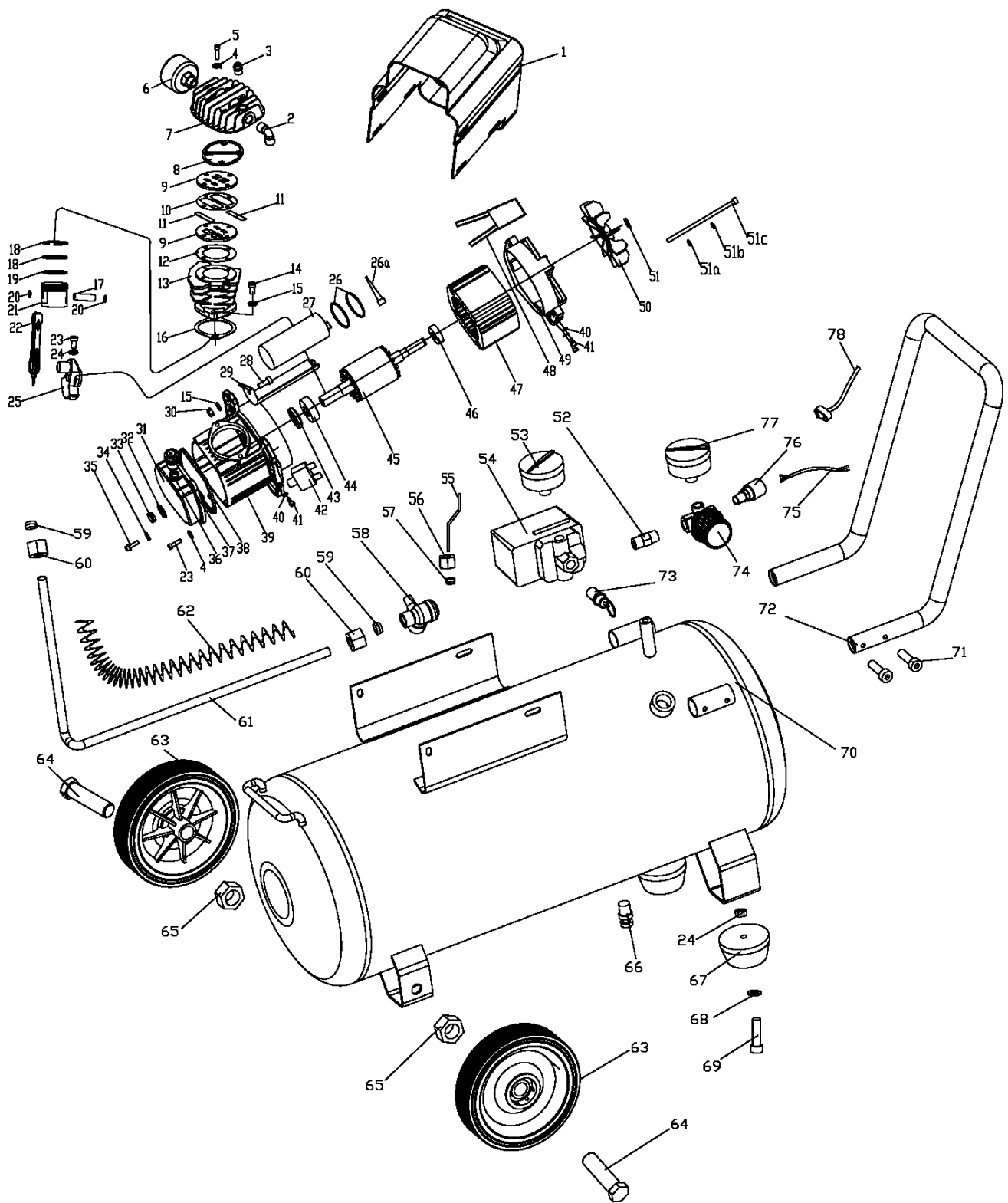

PLEASE READ THE FOLLOWING CAREFULLY

THE MANUFACTURER AND/OR DISTRIBUTOR HAS PROVIDED THE PARTS LIST AND ASSEMBLY DIAGRAM IN THIS MANUAL AS A REFERENCE TOOL ONLY. NEITHER THE MANUFACTURER OR DISTRIBUTOR MAKES ANY REPRESENTATION OR WARRANTY OF ANY KIND TO THE BUYER THAT HE OR SHE IS QUALIFIED TO MAKE ANY REPAIRS TO THE PRODUCT, OR THAT HE OR SHE IS QUALIFIED TO REPLACE ANY PARTS OF THE PRODUCT. IN FACT, THE MANUFACTURER AND/OR DISTRIBUTOR EXPRESSLY STATES THAT ALL REPAIRS AND PARTS REPLACEMENTS SHOULD BE UNDERTAKEN BY CERTIFIED AND LICENSED TECHNICIANS, AND NOT BY THE BUYER. THE BUYER ASSUMES ALL RISK AND LIABILITY ARISING OUT OF HIS OR HER REPAIRS TO THE ORIGINAL PRODUCT OR REPLACEMENT PARTS THERETO, OR ARISING OUT OF HIS OR HER INSTALLATION OF REPLACEMENT PARTS THERETO.

Record Product's Serial Number Here: _____

Note: If product has no serial number, record month and year of purchase instead.

Note: Some parts are listed and shown for illustration purposes only, and are not available individually as replacement parts.

Limited 90 Day Warranty

Harbor Freight Tools Co. makes every effort to assure that its products meet high quality and durability standards, and warrants to the original purchaser that this product is free from defects in materials and workmanship for the period of 90 days from the date of purchase. This warranty does not apply to damage due directly or indirectly, to misuse, abuse, negligence or accidents, repairs or alterations outside our facilities, criminal activity, improper installation, normal wear and tear, or to lack of maintenance. We shall in no event be liable for death, injuries to persons or property, or for incidental, contingent, special or consequential damages arising from the use of our product. Some states do not allow the exclusion or limitation of incidental or consequential damages, so the above limitation of exclusion may not apply to you. THIS WARRANTY IS EXPRESSLY IN LIEU OF ALL OTHER WARRANTIES, EXPRESS OR IMPLIED, INCLUDING THE WARRANTIES OF MERCHANTABILITY AND FITNESS.

To take advantage of this warranty, the product or part must be returned to us with transportation charges prepaid. Proof of purchase date and an explanation of the complaint must accompany the merchandise. If our inspection verifies the defect, we will either repair or replace the product at our election or we may elect to refund the purchase price if we cannot readily and quickly provide you with a replacement. We will return repaired products at our expense, but if we determine there is no defect, or that the defect resulted from causes not within the scope of our warranty, then you must bear the cost of returning the product.

This warranty gives you specific legal rights and you may also have other rights which vary from state to state.

CENTRALPNEUMATIC[®]

3491 Mission Oaks Blvd. • PO Box 6009 • Camarillo, CA 93011 • 1-888-866-5797