

CHICAGO welding
ELECTRIC systems

INVERTER ARC WELDER - 80 AMP

Model 91110

SET UP AND OPERATING INSTRUCTIONS

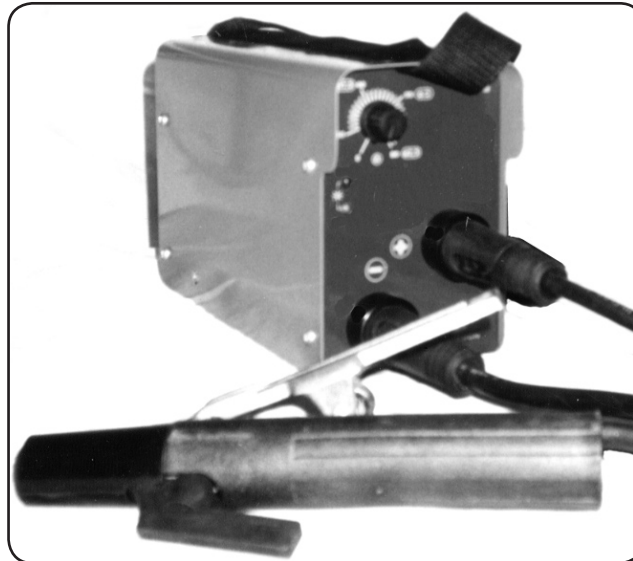

Distributed exclusively by Harbor Freight Tools®.

3491 Mission Oaks Blvd., Camarillo, CA 93011

Visit our website at: <http://www.harborfreight.com>



**Read this material before using this product.
Failure to do so can result in serious injury.
SAVE THIS MANUAL.**

Copyright© 2004 by Harbor Freight Tools®. All rights reserved. No portion of this manual or any artwork contained herein may be reproduced in any shape or form without the express written consent of Harbor Freight Tools. Diagrams within this manual may not be drawn proportionally. Due to continuing improvements, actual product may differ slightly from the product described herein.

For technical questions or replacement parts, please call 1-800-444-3353.

Revised 08b

SPECIFICATIONS

Electrical Input	120 V~ / 60 Hz / 20 A Power Cord: 12 Gauge With 3-Prong Plug Thermal Overload Protection
Electrode Sizes	1/16" - 3/32" (1.6mm) - (2.5mm)
Duty Cycles	35% @ 80 A 60% @ 65 A 100% @ 50 A
Electrode Cable	6 Gauge x 6' Long
Ground Clamp Cable	6 Gauge x 5'6" Long
Overall Dimensions	9-1/2" x 5-5/8" x 3-3/4"
Additional Features	Amber Temperature Warning Light
Welding Capacity	6 Gauge Steel

SAVE THIS MANUAL

You will need this manual for the safety warnings and precautions, assembly, operating, inspection, maintenance and cleaning procedures, parts list and assembly diagram. Keep your invoice with this manual. Write the invoice number on the inside of the front cover. Keep this manual and invoice in a safe and dry place for future reference.

UNPACKING

When unpacking, check to make sure all the parts shown on the **Parts List** are included. If any parts are missing or broken, please call Harbor Freight Tools at the number shown on the cover of this manual as soon as possible.

GENERAL SAFETY RULES



WARNING Read all safety warnings and instructions. *Failure to follow the warnings and instructions may result in electric shock, fire and/or serious injury.*

WORK AREA

- Keep your work area clean and well lit.** Cluttered benches and dark areas invite accidents.
- Do not operate power tools in explosive atmospheres, such as in the presence of flammable liquids, gases, or dust.** Power tools create sparks which may ignite the dust or fumes.
- Keep bystanders, children, and visitors away while operating a power tool.** Distractions can cause you to lose control. Protect others in the work area from debris such as chips and sparks. Provide barriers or shields as needed.

ELECTRICAL SAFETY

1. **Grounded tools must be plugged into an outlet properly installed and grounded in accordance with all codes and ordinances. Never remove the grounding prong or modify the plug in any way. Do not use any adapter plugs. Check with a qualified electrician if you are in doubt as to whether the outlet is properly grounded.** If the tools should electrically malfunction or break down, grounding provides a low resistance path to carry electricity away from the user.
2. **Double insulated tools are equipped with a polarized plug (one blade is wider than the other). This plug will fit in a polarized outlet only one way. If the plug does not fit fully in the outlet, reverse the plug. If it still does not fit, contact a qualified electrician to install a polarized outlet. Do not change the plug in any way.** Double insulation eliminates the need for the three wire grounded power cord and grounded power supply system.
3. **Avoid body contact with grounded surfaces such as pipes, radiators, ranges, and refrigerators.** There is an increased risk of electric shock if your body is grounded.
4. **Do not expose power tools to rain or wet conditions.** Water entering a power tool will increase the risk of electric shock.
5. **Do not abuse the Power Cord. Never use the Power Cord to carry the tools or pull the Plug from an outlet. Keep the Power Cord away from heat, oil, sharp edges, or**

moving parts. Replace damaged Power Cords immediately. Damaged Power Cords increase the risk of electric shock.

6. **When operating a power tool outside, use an outdoor extension cord marked “W-A” or “W”.** These extension cords are rated for outdoor use, and reduce the risk of electric shock.

PERSONAL SAFETY

1. **Stay alert. Watch what you are doing, and use common sense when operating a power tool. Do not use a power tool while tired or under the influence of drugs, alcohol, or medication.** A moment of inattention while operating power tools may result in serious personal injury.
2. **Dress properly. Do not wear loose clothing or jewelry. Contain long hair. Keep your hair, clothing, and gloves away from moving parts.** Loose clothes, jewelry, or long hair can be caught in moving parts.
3. **Avoid accidental starting. Be sure the Power Switch is off before plugging in.** Carrying power tools with your finger on the Power Switch, or plugging in power tools with the Power Switch on, invites accidents.
4. **Remove adjusting keys or wrenches before turning the power tool on.** A wrench or a key that is left attached to a rotating part of the power tool may result in personal injury.
5. **Do not overreach. Keep proper footing and balance at all times.** Proper footing and balance enables

better control of the power tool in unexpected situations.

6. **Use safety equipment. Always wear eye protection.** Always wear ANSI-approved safety glasses under a properly shaded welding helmet. Respirator, leather work shoes with rubber soles, hard hat or hearing protection must be used for appropriate conditions.

TOOL USE AND CARE

1. **Use clamps (not included) or other practical ways to secure and support the work piece to a stable platform.** Holding the work by hand or against your body is unstable and may lead to loss of control.
2. **Do not force the tool. Use the correct tool for your application.** The correct tool will do the job better and safer at the rate for which it is designed.
3. **Do not use the power tool if the Power Switch does not turn it on or off.** Any tool that cannot be controlled with the Power Switch is dangerous and must be replaced.
4. **Disconnect the Power Cord Plug from the power source before making any adjustments, changing accessories, or storing the tool.** Such preventive safety measures reduce the risk of starting the tool accidentally.
5. **Store idle tools out of reach of children and other untrained persons.** Tools are dangerous in the hands of untrained users.

6. **Maintain tools with care. Keep cutting tools sharp and clean.** Properly maintained tools with a sharp cutting edge are less likely to bind and are easier to control. Do not use a damaged tool. Tag damaged tools "Do not use" until repaired.
7. **Check for misalignment or binding of moving parts, breakage of parts, and any other condition that may affect the tool's operation. If damaged, have the tool serviced before using.** Many accidents are caused by poorly maintained tools.
8. **Use only accessories that are recommended by the manufacturer for your model.** Accessories that may be suitable for one tool may become hazardous when used on another tool.

SERVICE

1. **Tool service must be performed only by qualified repair personnel.** Service or maintenance performed by unqualified personnel could result in a risk of injury.
2. **When servicing a tool, use only identical replacement parts. Follow instructions in the "Inspection, Maintenance, And Cleaning" section of this manual.** Use of unauthorized parts or failure to follow maintenance instructions may create a risk of electric shock or injury.

SPECIFIC SAFETY RULES

1. **Maintain a safe working environment.** Keep the work area well lit. Make sure there is adequate surrounding workspace. Always keep

the work area free of obstructions, grease, oil, trash, and other debris. Do not use the Inverter Arc Welder in areas near flammable chemicals, dusts, and vapors.

2. **Maintain labels and nameplates on the Inverter Arc Welder.** These carry important information. If unreadable or missing, contact Harbor Freight Tools for a replacement.
3. **Never plug the Power Cord of this product into an electrical outlet while standing on a wet or damp surface.**
4. **Do not unplug the Inverter Arc Welder by pulling on the Power Cord. Keep the Power Cord away from heated surfaces.**
5. **Always turn off the Inverter Arc Welder and unplug the unit from its electrical outlet before performing any inspection, maintenance, or cleaning procedures.**
6. **Never leave the Inverter Arc Welder unattended when it is plugged into an electrical outlet.** Make sure to unplug it from its electrical outlet before leaving the area.
7. **Do not allow children to handle or play with this product.**
8. **Store idle equipment.** When not in use, tools and equipment should be stored in a dry location to inhibit rust. Always lock up tools and equipment, and keep out of reach of children.
9. **Do not use this product if under the influence of alcohol or drugs.** Read warning labels on prescriptions to determine if your judgement or reflexes are impaired while taking

drugs. If there is any doubt, do not attempt to use this product.

⚠️ WARNING



INHALATION HAZARD: Welding and Plasma Cutting Produce TOXIC FUMES.

Exposure to welding or cutting exhaust fumes can increase the risk of developing certain cancers, such as cancer of the larynx and lung cancer. Also, some diseases that may be linked to exposure to welding or plasma cutting exhaust fumes are:

- Early onset of Parkinson's Disease
- Heart disease
- Ulcers
- Damage to the reproductive organs
- Inflammation of the small intestine or stomach
- Kidney damage
- Respiratory diseases such as emphysema, bronchitis, or pneumonia

Use natural or forced air ventilation and wear a respirator approved by NIOSH to protect against the fumes produced to reduce the risk of developing the above illnesses.

11. **Use eye, skin, and breathing protection.** Always wear ANSI approved safety glasses with side shields under an ANSI approved welding helmet. Wear fire resistant work gloves, a heavy, long-sleeved shirt, trousers without cuffs, high top leather work boots to protect skin from arc rays and metal sparks. Also wear an ANSI approved air respirator.

12. **Industrial applications must follow OSHA requirements.**
13. **Maintain this product with care.** Keep this product clean and dry for better and safer performance.
14. **Maintenance:** For your safety, service and maintenance should be performed regularly by a qualified technician.
15. **Check for damaged parts.** Before using this product, carefully check that it will operate properly and perform its intended function. Check for damaged parts and any other condition that may affect the operation of this product. Replace or repair damaged or worn parts immediately.
16. **Connect the earth ground as near as possible to the operating area. Earth connections to structural parts of the building or other places distant to the operating area will reduce their effectiveness and increase the danger of electric shock.**
17. **Do not pass equipment cables through or near lifting chains, crane cables, or any electrical lines.**
18. **In addition to grounding the work piece with the Inverter Arc Welder Grounding Cable, an earth grounding of the work piece is recommended.** Ground it directly to an earth pipe or grounding rod with a separate cable of appropriate size. **IMPORTANT:** Only a qualified, certified electrician should perform this procedure.
19. **Do not touch the electrode if you are in contact with the work piece, ground, or another electrode from a different machine.**
20. **Never use the Inverter Arc Welder near water.** Ensure that the surrounding area and cutting objects are dry. Do not spray water or other liquids on or near the Inverter Arc Welder.
21. **Avoid all direct contact between the skin and wet garments and metal parts under electrical power.** Check that gloves and protective clothing are dry.
22. **Always wear welding gloves and rubber soled leather work boots when working in damp areas or standing on metal objects.**
23. **Always turn off the Inverter Arc Welder in the event of a power failure.**
24. **Do not allow the Electrode Holder to touch earth ground.** Accidental earth discharges may cause overheating and fire hazards.
25. **Significant DC voltage exists after turning off and unplugging the Inverter Arc Welder.** Discharge the electrode to ground before handling.
26. **Position a fire-resistant screen (not included) around the welding area to protect people in the vicinity from arc rays, sparks, and slag.**
27. **Clear away or protect flammable objects.** Protect objects such as wood, sawdust, clothing, paints, solvents, petroleum products, natural gas, acetylene, propane, and other substances with fireproof material (not included).

28. **Keep an ABC type fire extinguisher near the work area.**
29. **Never perform welding or cutting operations on closed pipes or containers, as the possible internal fumes may cause an explosion.**
30. **Never perform welding or cutting operations on open pipes or containers that may have come in contact with moisture, chemicals, or flammable materials.** Always clean and dry the areas first.
31. **Welding and cutting fumes and gases may be hazardous if inhaled for long periods of time.**
32. **Install a natural or forced-air ventilation system in the work area.** If the ventilation system is inadequate, use an air respirator.
33. **Use a forced-air ventilation system when welding or cutting lead, beryllium, cadmium, zinc, zinc-coated or painted materials.** Always wear an air respirator.
34. **When welding or cutting in small areas, the operator should be externally accompanied by another person (standing *near* the enclosed work area) to observe accident prevention procedures.**
35. **Do not perform welding or cutting operations near chlorinated hydrocarbon vapors produced by degreasing or painting.** The heat generated by arc rays can react to form phosgene, a highly toxic gas.
36. **Irritation of the eyes, nose, and throat are symptoms of inadequate ventilation.** Take immediate steps to improve ventilation. Do not continue operations if symptoms persist.
37. **Electric shock can be fatal.** Never touch exposed electrical parts.
38. **Switch off and disconnect the power source before installing the Inverter Arc Welder.**
39. **Installation must be performed by a qualified technician.** Installation procedures must comply with the National Electric Code, and all other relevant regulations.
40. **When welding or cutting, be aware that high frequency radiation may be produced which can interfere with radio navigation, safety devices, computers, and communications equipment.** Before operating, have a qualified technician check out that possibility.
41. **Keep high frequency source doors and panels tightly shut.** Keep spark gaps at the correct settings. Use proper grounding and shielding to minimize the possibility of interference. Keep all cables close together and close to the ground. Locate the welding or cutting operation as far as possible from sensitive electronic equipment, or have the electronic equipment shut down temporarily.
42. **Performance of this Inverter Arc Welder may vary depending on variations in local line voltage.** Extension cord usage may also affect tool performance.
43. **Welding and cutting operations are a source of radiation, noise, heat, and noxious fumes.** The protection of the operator and any spectators must be guaranteed with suit-

able safety devices and precautions. Never approach arc rays or hot metal without protection. Failure to observe these standards during operation could lead to serious health risks.

44. **Use the right tool or attachment for the right job.** Do not attempt to force a small tool or attachment to do the work of a larger industrial tool or attachment. There are certain applications for which this product was designed. It will do the job better and more safely at the rate for which it was intended. Do not modify this product, and do not use this product for a purpose for which it was not intended.

45. **Replacement parts and accessories:** When servicing, use only identical replacement parts. Only use accessories intended for use with this product.

46. **WARNING:** The brass components of this product contain lead, a chemical known to the State of California to cause birth defects (or other reproductive harm). (California Health & Safety code § 25249.5, *et seq.*)

47. **WARNING:** This product, when used for welding, plasma cutting, soldering, or similar applications, produces chemicals known to the State of California to cause cancer and birth defects (or other reproductive harm). (California Health & Safety Code § 25249.5, *et seq.*)

48. People with pacemakers should consult their physician(s) before use. Electromagnetic fields in close proximity to heart pacemaker could cause pacemaker interference or pacemak-

er failure. In addition, people with pacemakers should:

- Avoid operating alone.
- Don't use with power switch locked on.
- Properly maintain and inspect to avoid electrical shock.
- Any power cord must be properly grounded. Ground Fault Circuit Interrupter (GFCI) should also be implemented – it prevents sustained electrical shock.

49. The warnings, precautions, and instructions discussed in this instruction manual cannot cover all possible conditions and situations that may occur. It must be understood by the operator that common sense and caution are factors which cannot be built into this product, but must be supplied by the operator.

GROUNDING

⚠️ WARNING TO PREVENT ELECTRIC SHOCK



AND DEATH FROM INCORRECT GROUNDING WIRE CONNECTION:

Check with a qualified electrician if you are in doubt as to whether the outlet is properly grounded. Do not modify the power cord plug provided with the tool. Never remove the grounding prong from the plug. Do not use the tool if the power cord or plug is damaged. If damaged, have it repaired by a service facility before use. If the plug will not fit the outlet, have a proper outlet installed by a qualified electrician.

Grounded Tools: Tools with Three Prong Plugs

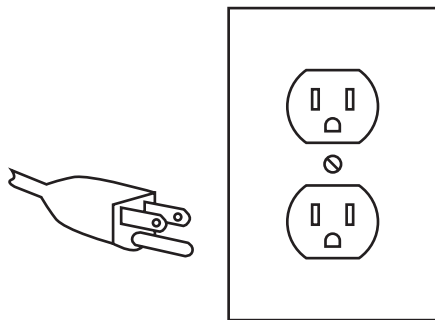

3-Prong Plug and Outlet

1. Tools marked with “Grounding Required” have a three wire cord and three prong grounding plug. The plug must be connected to a properly grounded outlet. If the tool should electrically malfunction or break down, grounding provides a low resistance path to carry electricity away from the user, reducing the risk

of electric shock. (See **3-Prong Plug and Outlet.**)

2. The grounding prong in the plug is connected through the green wire inside the cord to the grounding system in the tool. The green wire in the cord must be the only wire connected to the tool’s grounding system and must never be attached to an electrically “live” terminal. (See **3-Prong Plug and Outlet.**)
3. The tool must be plugged into an appropriate outlet, properly installed and grounded in accordance with all codes and ordinances. The plug and outlet should look like those in the preceding illustration. (See **3-Prong Plug and Outlet.**)

Double Insulated Tools: Tools with Two Prong Plugs

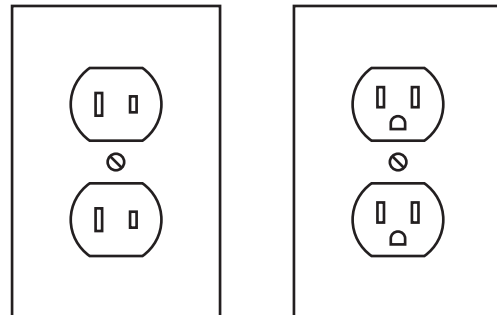

Outlets for 2-Prong Plug

1. Tools marked “Double Insulated” do not require grounding. They have a special double insulation system which satisfies OSHA requirements and complies with the applicable standards of Underwriters Laboratories, Inc., the Canadian Standard Association, and the National Electrical Code. (See **Outlets for 2-Prong Plug.**)

- Double insulated tools may be used in either of the 120 volt outlets shown in the preceding illustration. **(See Outlets for 2-Prong Plug.)**

Extension Cords

- Grounded** tools require a three wire extension cord. **Double Insulated** tools can use either a two or three wire extension cord.
- As the distance from the supply outlet increases, you must use a heavier gauge extension cord. Using extension cords with inadequately sized wire causes a serious drop in voltage, resulting in loss of power and possible tool damage. **(See Table A.)** The smaller the gauge number of the wire, the greater the capacity of the cord. For example, a 14 gauge cord can carry a higher current than a 16 gauge cord. **(See Table A.)**
- When using more than one extension cord to make up the total length, make sure each cord contains at least the minimum wire size required. **(See Table A.)**
- If you are using one extension cord for more than one tool, add the nameplate amperes and use the sum to determine the required minimum cord size. **(See Table A.)**
- If you are using an extension cord outdoors, make sure it is marked with the suffix "W-A" ("W" in Canada) to indicate it is acceptable for outdoor use.
- Make sure the extension cord is properly wired and in good electrical condition. Always replace a damaged

extension cord or have it repaired by a qualified electrician before using it.







- Protect the extension cords from sharp objects, excessive heat, and damp or wet areas.

RECOMMENDED MINIMUM WIRE GAUGE FOR EXTENSION CORDS* (120/240 VOLT)					
NAMEPLATE AMPERES (at full load)	EXTENSION CORD LENGTH				
	25'	50'	75'	100'	150'
0 – 2.0	18	18	18	18	16
2.1 – 3.4	18	18	18	16	14
3.5 – 5.0	18	18	16	14	12
5.1 – 7.0	18	16	14	12	12
7.1 – 12.0	18	14	12	10	-
12.1 – 16.0	14	12	10	-	-
16.1 – 20.0	12	10	-	-	-

*** Based on limiting the line voltage drop to five volts at 150% of the rated amperes.**

TABLE A

Symbology

	Double Insulated
	Canadian Standards Association
	Underwriters Laboratories, Inc.
	Volts Alternating Current
	Amperes
	No Load Revolutions per Minute (RPM)

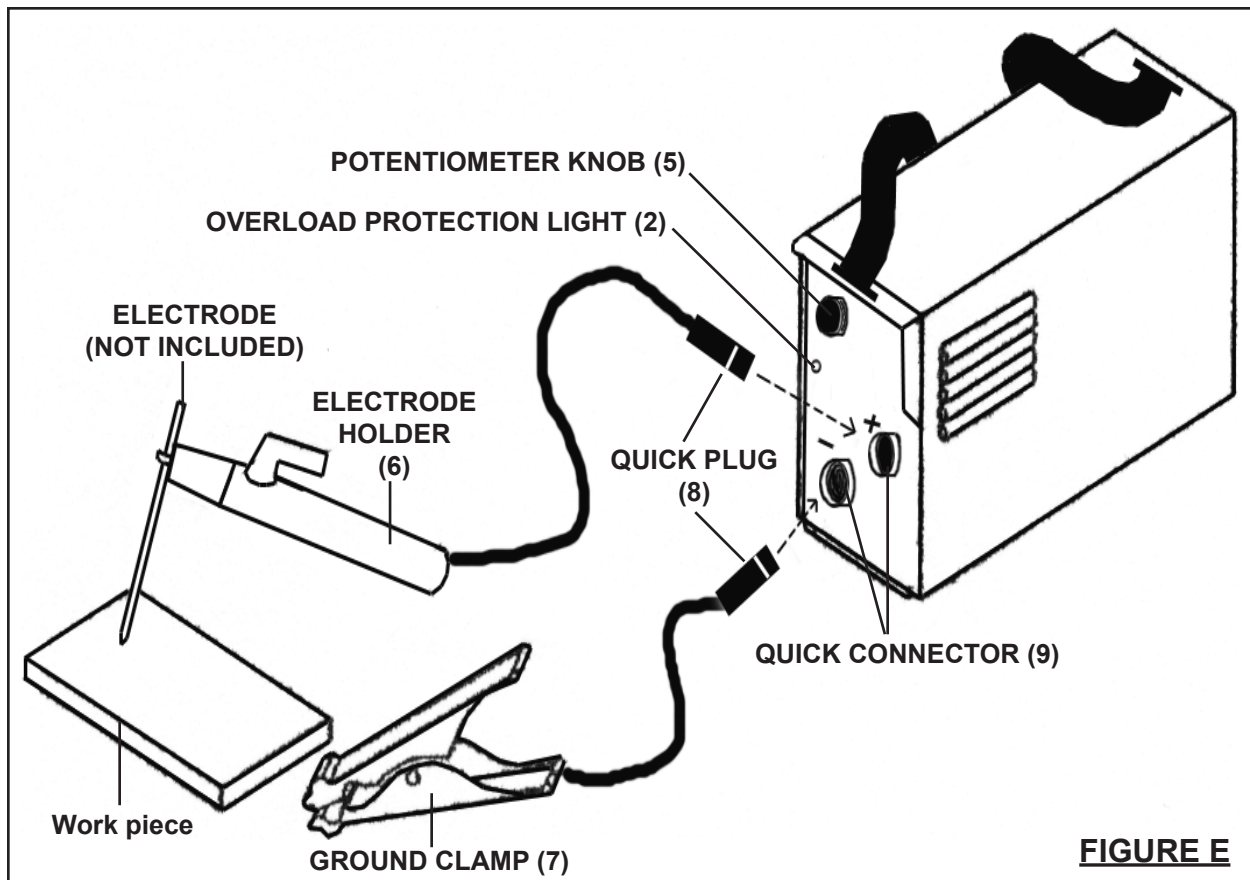

FIGURE E

ASSEMBLY AND OPERATING INSTRUCTIONS

NOTE: For additional references to the parts listed in the following pages, refer to the **Assembly Diagram**.

⚠WARNING Prior to performing any assembly procedures, make sure the Power Cord of the Inverter Arc Welder is unplugged from its electrical outlet.

1. Connect the Quick Plug (8) to the **negative (-)** Quick Connector (9) on the Inverter Arc Welder. Also connect the Ground Clamp (7) to the work piece or to a metal welding table where the work piece will be placed. (See Figure E.)

2. Connect the Electrode Holder (6) to the **positive (+)** Quick Connector on the front of the Inverter Arc Welder. Install an electrode (not included) into the Electrode Holder by squeezing the Holder while positioning the electrode at the desired angle. (See Figure E.)

3. Plug the Power Cord (16) into the nearest 120 volt, grounded, electrical outlet.

⚠WARNING! Wear ANSI-approved safety glasses under a properly shaded welding helmet.

4. Hold the Electrode Holder (6) away from all objects. Then, position the Potentiometer Knob (5) to about mid-range to start. (See Figure E.)

5. To begin welding, position the electrode at about a 60 degree angle and touch the tip of it to the work piece. Once the arc is stable, move the electrode along the work piece and down as the welding process consumes the electrode. Replace the electrode as needed to complete the job. **(See Figure E.)**
6. If necessary, adjust the Potentiometer Knob (5) to increase or decrease the electrical current output to achieve the desired performance and weld results. **(See Figure E.)**

NOTE: The Inverter Arc Welder is equipped with an automatic “Hot Start”. This feature momentarily surges the current output, which makes starting the electrode easier. Should the electrode stick to the work piece, usually a quick twist of the Electrode Holder (6) will break the electrode free. If the electrode is not broken loose, shut down the Inverter Arc Welder and physically remove the electrode from the Electrode Holder and work piece. **CAUTION! The electrode and metal are hot.**

7. When the job is completed, turn the Potentiometer Knob (5) to its “OFF” position, and unplug the Power Cord (16) from its electrical outlet. Then, remove the Ground Clamp (7) from the work piece or metal table. **(See Figure E.)**

Electrode Size and Amp Chart

Electrode Diameter (Thickness)	Amp Range	Plate
1/16"	20 - 40	up to 3/16"
3/32"	40 - 125	up to 1/4"
1/8	75 - 185	over 1/8"
5/32"	105 - 250	over 1/4"
3/16"	140 - 305	over 3/8"
1/4"	210 - 430	over 3/8"
5/16"	275 - 450	over 1/2"

Ratings listed above are estimates and will vary depending on electrode coating and electrode manufacturer. When possible, use the manufacturer’s recommended amperage setting instead.

INSPECTION, MAINTENANCE, AND CLEANING

⚠️ WARNING

**Make sure the
Potentiometer**

**Knob (5) is in its “OFF”
position. Unplug the Power
Cord (16) from its electrical
outlet, and allow the Inverter
Arc Welder and discharge
electrode to completely cool
before performing any
inspection, maintenance, or
cleaning procedures.**

1. **Before each use**, inspect the general condition of the Inverter Arc Welder. Check for damaged electrical wiring, loose connections, cracked, burnt, or broken parts, and any other condition that may affect its safe operation. If abnormal noise or vibration occurs, have the problem corrected before further use.
Do not use damaged equipment.
2. **Before each use**, clean or, if necessary, replace the electrode.
3. **To clean**, use a shop vacuum cleaner, or use compressed air.
4. **When storing**, make sure to store the Inverter Arc Welder in a safe, clean, and dry location.

TROUBLESHOOTING GUIDE

1. **The Inverter Arc Welder will not turn on.**
 - a. Make sure the Power Cord (16) is plugged in.
 - b. Make sure the Quick Plugs (8) are properly plugged into the Quick Connectors (9).
2. **The Inverter Arc Welder is turned on, but will not strike an arc.**
 - a. Make sure the electrode is securely attached to the Electrode Holder (6).
 - b. Make sure the Quick Plugs (8) are properly plugged into the Quick Connectors (9).
 - c. Make sure the Ground Clamp (7) is securely attached to the work piece or metal table on which the work piece is placed, and that the point of attachment is clean from rust, paint, or any other material that would insulate the connection.
3. **The Inverter Arc Welder is not working, and the Overload Protection Light (2) is on.**
 - a. When the Inverter Arc Welder overheats it will automatically shut down temporarily. When this happens stop welding, but leave the Welder on until it cools down. As soon as the Overload Protection Light goes off you may continue welding.
 - b. If the Welder does not cool down as described above, check to see if the Fan (13) is operating. If the Fan is operating, check the side panel vents to see if anything is obstructing airflow from the Fan. If obstructions exist, remove them and wait for the Welder to cool while observing the Overload Protection Light (2).
4. **The current output is unstable and unable to produce a smooth welding bead.**
 - a. Make sure the Power Cord (16) is properly connected to its electrical outlet.

- b. Make sure the Quick Plugs (8) are securely connected to the Quick Connectors (9).
- c. Make sure the Ground Clamp (7) is securely attached to the work piece or metal table on which the work piece is placed, and that the point of attachment is clean from rust, paint, or any other material that would insulate the connection.
- d. Make sure the electrode is in good condition, and that the welding current output is properly adjusted. (*Increasing* the current output usually improves this situation.)

**PLEASE READ THE FOLLOWING
CAREFULLY**

THE MANUFACTURER AND/OR DISTRIBUTOR HAS PROVIDED THE PARTS LIST AND ASSEMBLY DIAGRAM IN THIS MANUAL AS A REFERENCE TOOL ONLY. NEITHER THE MANUFACTURER OR DISTRIBUTOR MAKES ANY REPRESENTATION OR WARRANTY OF ANY KIND TO THE BUYER THAT HE OR SHE IS QUALIFIED TO MAKE ANY REPAIRS TO THE PRODUCT, OR THAT HE OR SHE IS QUALIFIED TO REPLACE ANY PARTS OF THE PRODUCT. IN FACT, THE MANUFACTURER AND/OR DISTRIBUTOR EXPRESSLY STATES THAT ALL REPAIRS AND PARTS REPLACEMENTS SHOULD BE UNDERTAKEN BY CERTIFIED AND LICENSED TECHNICIANS, AND NOT BY THE BUYER. THE BUYER ASSUMES ALL RISK AND LIABILITY ARISING OUT OF HIS OR HER REPAIRS TO THE ORIGINAL PRODUCT OR REPLACEMENT PARTS THERETO, OR ARISING OUT OF HIS OR HER INSTALLATION OF REPLACEMENT PARTS THERETO.

PARTS LIST

Part	Description
1	Potentiometer
2	Overload Protection Light
3	PCB
4	Nut (M6), Washer
5	Potentiometer Knob
6	Electrode Holder
7	Ground Clamp
8	Quick Plug
9	Quick Connector
10	Steel Base
11	Screw (M8), Washer, Spring Washer Nut (M14 x 1), Fitting Washer, Support
12	Plastic Tube

Part	Description
13	Fan
14	Cable Fixture
15	Tapping Screw (M4 x 20)
16	Power Cord
17	Tapping Screw (4.8 x 9mm)
18	Earth Rivet
19	Tapping Screw (4.2 x 9mm)
20	Steel Cover
21	Belt
22	Radiator
23	Transformer
24	Capacitor
25	Radiator

ASSEMBLY DIAGRAM

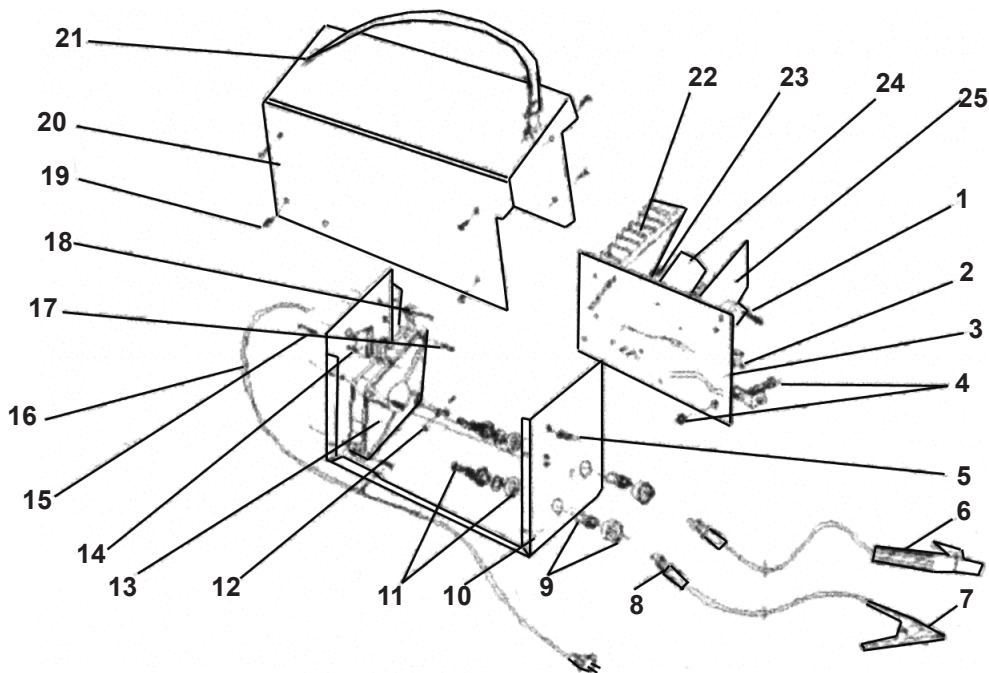

NOTE: Some parts are listed and shown for illustration purposes only, and are not available individually as replacement parts.

LIMITED 90 DAY WARRANTY

Harbor Freight Tools Co. makes every effort to assure that its products meet high quality and durability standards, and warrants to the original purchaser that this product is free from defects in materials and workmanship for the period of 90 days from the date of purchase. This warranty does not apply to damage due directly or indirectly, to misuse, abuse, negligence or accidents, repairs or alterations outside our facilities, criminal activity, improper installation, normal wear and tear, or to lack of maintenance. We shall in no event be liable for death, injuries to persons or property, or for incidental, contingent, special or consequential damages arising from the use of our product. Some states do not allow the exclusion or limitation of incidental or consequential damages, so the above limitation of exclusion may not apply to you. THIS WARRANTY IS EXPRESSLY IN LIEU OF ALL OTHER WARRANTIES, EXPRESS OR IMPLIED, INCLUDING THE WARRANTIES OF MERCHANTABILITY AND FITNESS.

To take advantage of this warranty, the product or part must be returned to us with transportation charges prepaid. Proof of purchase date and an explanation of the complaint must accompany the merchandise. If our inspection verifies the defect, we will either repair or replace the product at our election or we may elect to refund the purchase price if we cannot readily and quickly provide you with a replacement. We will return repaired products at our expense, but if we determine there is no defect, or that the defect resulted from causes not within the scope of our warranty, then you must bear the cost of returning the product.

This warranty gives you specific legal rights and you may also have other rights which vary from state to state.

3491 Mission Oaks Blvd. • PO Box 6009 • Camarillo, CA 93011 • (800) 444-3353