



2-Bike Hitch Rack

Item 98019

INSTRUCTIONS AND PRECAUTIONS



Visit our website at:
<http://www.harborfreight.com>

⚠ WARNING

Read this material before using this product. Failure to do so can result in serious injury. SAVE THIS MANUAL.

When unpacking, make sure that the product is intact and undamaged. If any parts are missing or broken, please call 1-800-444-3353 as soon as possible.

Copyright© 2008 by Harbor Freight Tools®. All rights reserved. No portion of this document or any artwork contained herein may be reproduced in any shape or form without the express written consent of Harbor Freight Tools. Diagrams within this document may not be drawn proportionally. Due to continuing improvements, actual product may differ slightly from the product described herein. Tools required for assembly and service may not be included.

For technical questions or replacement parts, please call 1-800-444-3353.

Specifications

Maximum Weight Capacity	100 lbs
Bike Capacity	2
Holding Mechanism	Thermoplastic Bike Holders, Hook & Loop Straps
Hitch Classes	Used with Class I, II, III, IV Hitches
Swing-down feature	For opening hatches

Unpacking

When unpacking, check to make sure that the item is intact and undamaged. If any parts are missing or broken, please call Harbor Freight Tools at the number shown on the cover of this document as soon as possible.

Important Safety Information

1. Assemble only according to these instructions. Improper assembly can create hazards.
2. Wear ANSI-approved safety goggles and heavy-duty work gloves during assembly.
3. Keep assembly area clean and well lit.
4. Keep bystanders out of the area during assembly.
5. Do not assemble when tired or when under the influence of drugs or medication.
6. Do not exceed 55 MPH with Carrier attached.
7. Contact the Department of Transportation (DOT) and check local regulations for laws regarding the installation and use of this bike rack.
8. This product is not a toy. Do not allow children to play with or on this item.
9. Use for intended purpose(s) only.
10. Inspect before use; do not use if parts are loose or damaged.
11. Maintain product labels and nameplates. These carry important safety information. If unreadable or missing, contact Harbor Freight Tools for a replacement.

Instructions



Read the **ENTIRE INSTRUCTIONS AND PRECAUTIONS** section at the beginning of this document including all text under subheadings therein before set up or use of this product.

Assembly

1. Slide the Hitch End of the Linker (1) into the vehicle's trailer hitch and lock with a steel pin. See Figure 1.
2. Install the Support Column (2) to the upright part of the Linker (1) and secure with a Bolt (5), Nut (7) and two Washers (6), through the bottom hole and the Hitch Pin (4) through the upper hole. When the back hatch or tailgate has to be accessed, pull the Hitch Pin (4) out and swing the rack downward, pivoting at the bolt directly below the Hitch Pin (4).
3. Hold the two Bike Rack (3) sections over the upper end of the Support Column (2) aligning the bolt holes. Secure this with two Bolts (5), four Washers (6) and two Nuts (7).
4. Double check all nuts and bolts, making sure they are all tight.

Operation

Note: This rack is designed to hold up to two bikes.

1. Make sure that the holders are facing upwards. Open the straps and place the bicycle's cross-bar onto the holders. Close the straps over the bike, pressing the straps together for a secure hold. Place the second bike facing in the opposite direction and secure it with the hook & loop straps as well.
2. The Thermoplastic Holders keep the bike(s) in position, preventing them from sliding back and forth, causing damage. The straps keep the bikes from bumping out of the holders.

Note: It is recommended that if you plan to carry only one bike, you can place it in the position closest to the vehicle.

Parts List and Diagram

Part	Description	Qty
1	Linker	1
2	Support Column	1
3	Bike Rack	2
4	Hitch Pin	1
5	Bolt	3
6	Washer	6
7	Self Locking Nut	3
8	Holder	4

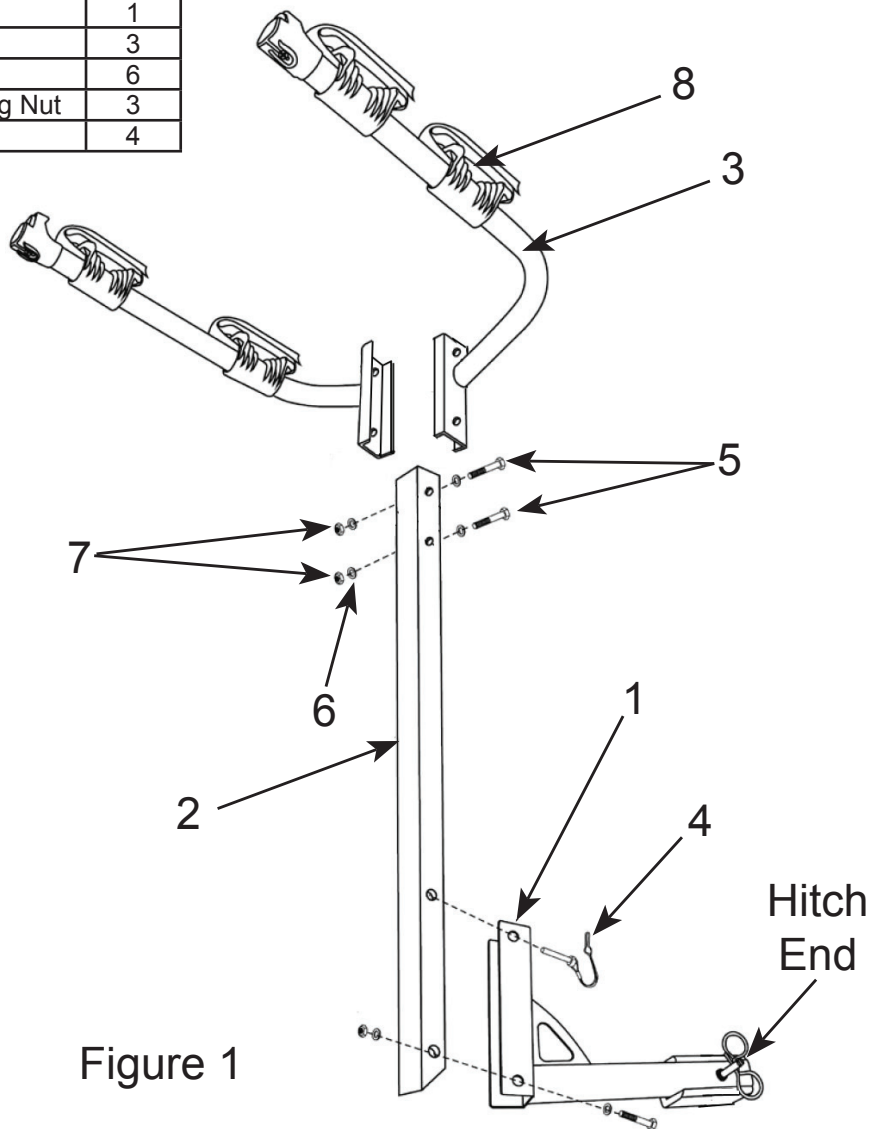

Figure 1

Record Serial Number Here: _____

Note: If product has no serial number, record month and year of purchase instead.

Note: Some parts are listed and shown for illustration purposes only, and are not available individually as replacement parts.

PLEASE READ THE FOLLOWING CAREFULLY

THE MANUFACTURER AND/OR DISTRIBUTOR HAS PROVIDED THE PARTS LIST AND ASSEMBLY DIAGRAM IN THIS DOCUMENT AS A REFERENCE TOOL ONLY. NEITHER THE MANUFACTURER OR DISTRIBUTOR MAKES ANY REPRESENTATION OR WARRANTY OF ANY KIND TO THE BUYER THAT HE OR SHE IS QUALIFIED TO MAKE ANY REPAIRS TO THE PRODUCT, OR THAT HE OR SHE IS QUALIFIED TO REPLACE ANY PARTS OF THE PRODUCT. IN FACT, THE MANUFACTURER AND/OR DISTRIBUTOR EXPRESSLY STATES THAT ALL REPAIRS AND PARTS REPLACEMENTS SHOULD BE UNDERTAKEN BY CERTIFIED AND LICENSED TECHNICIANS, AND NOT BY THE BUYER. THE BUYER ASSUMES ALL RISK AND LIABILITY ARISING OUT OF HIS OR HER REPAIRS TO THE ORIGINAL PRODUCT OR REPLACEMENT PARTS THERETO, OR ARISING OUT OF HIS OR HER INSTALLATION OF REPLACEMENT PARTS THERETO.

REV 11c

Limited 90 Day Warranty

Harbor Freight Tools Co. makes every effort to assure that its products meet high quality and durability standards, and warrants to the original purchaser that this product is free from defects in materials and workmanship for the period of 90 days from the date of purchase. This warranty does not apply to damage due directly or indirectly, to misuse, abuse, negligence or accidents, repairs or alterations outside our facilities, criminal activity, improper installation, normal wear and tear, or to lack of maintenance. We shall in no event be liable for death, injuries to persons or property, or for incidental, contingent, special or consequential damages arising from the use of our product. Some states do not allow the exclusion or limitation of incidental or consequential damages, so the above limitation of exclusion may not apply to you. THIS WARRANTY IS EXPRESSLY IN LIEU OF ALL OTHER WARRANTIES, EXPRESS OR IMPLIED, INCLUDING THE WARRANTIES OF MERCHANTABILITY AND FITNESS.

To take advantage of this warranty, the product or part must be returned to us with transportation charges prepaid. Proof of purchase date and an explanation of the complaint must accompany the merchandise. If our inspection verifies the defect, we will either repair or replace the product at our election or we may elect to refund the purchase price if we cannot readily and quickly provide you with a replacement. We will return repaired products at our expense, but if we determine there is no defect, or that the defect resulted from causes not within the scope of our warranty, then you must bear the cost of returning the product.

This warranty gives you specific legal rights and you may also have other rights which vary from state to state.



3491 Mission Oaks Blvd. • PO Box 6009 • Camarillo, CA 93011 • (800) 444-3353