

Owner's Manual & Safety Instructions

Save This Manual Keep this manual for the safety warnings and precautions, assembly, operating, inspection, maintenance and cleaning procedures. Write the product's serial number in the back of the manual near the assembly diagram (or month and year of purchase if product has no number). Keep this manual and the receipt in a safe and dry place for future reference.

CHICAGO  **ELECTRIC**
POWER TOOLS

ITEM 98199

10" SLIDING COMPOUND MITER SAW



Visit our website at: <http://www.harborfreight.com>
Email our technical support at: productsupport@harborfreight.com

REV 13k

When unpacking, make sure that the product is intact and undamaged. If any parts are missing or broken, please call 1-888-866-5797 as soon as possible.

Copyright© 2008 by Harbor Freight Tools®. All rights reserved.
No portion of this manual or any artwork contained herein may be reproduced in any shape or form without the express written consent of Harbor Freight Tools. Diagrams within this manual may not be drawn proportionally. Due to continuing improvements, actual product may differ slightly from the product described herein.
Tools required for assembly and service may not be included.

WARNING

**Read this material before using this product.
Failure to do so can result in serious injury.
SAVE THIS MANUAL.**

Table of Contents

Safety	3	Maintenance	13
Setup	7	Parts List and Diagram	17
Specifications	7	Warranty	20
Operation.....	10		

SAFETY





CHICAGO ELECTRIC[®] POWER TOOLS

SETUP

OPERATION

MAINTENANCE

WARNING SYMBOLS AND DEFINITIONS

	This is the safety alert symbol. It is used to alert you to potential personal injury hazards. Obey all safety messages that follow this symbol to avoid possible injury or death.
	Indicates a hazardous situation which, if not avoided, will result in death or serious injury.
	Indicates a hazardous situation which, if not avoided, could result in death or serious injury.
	Indicates a hazardous situation which, if not avoided, could result in minor or moderate injury.
	Addresses practices not related to personal injury.

IMPORTANT SAFETY INFORMATION

General Tool Safety Warnings

⚠️ WARNING

Read all safety warnings and instructions.

Failure to follow the warnings and instructions may result in electric shock, fire and/or serious injury.

Save all warnings and instructions for future reference.

1. KEEP GUARDS IN PLACE and in working order.
2. REMOVE ADJUSTING KEYS AND WRENCHES. Form habit of checking to see that keys and adjusting wrenches are removed from tool before turning it on.
3. KEEP WORK AREA CLEAN. Cluttered areas and benches invite accidents.
4. DON'T USE IN DANGEROUS ENVIRONMENT. Don't use power tools in damp or wet locations, or expose them to rain. Keep work area well lighted.
5. KEEP CHILDREN AWAY. All visitors should be kept safe distance from work area.
6. MAKE WORKSHOP KID PROOF with padlocks, master switches, or by removing starter keys.
7. DON'T FORCE TOOL. It will do the job better and safer at the rate for which it was designed.
8. USE RIGHT TOOL. Don't force tool or attachment to do a job for which it was not designed.
10. WEAR PROPER APPAREL. Do not wear loose clothing, gloves, neckties, rings, bracelets, or other jewelry which may get caught in moving parts. Nonslip footwear is recommended. Wear protective hair covering to contain long hair.
11. ALWAYS USE SAFETY GLASSES. Also use face or dust mask if cutting operation is dusty. Everyday eyeglasses only have impact resistant lenses, they are NOT safety glasses.
12. SECURE WORK. Use clamps or a vise to hold work when practical. It's safer than using your hand and it frees both hands to operate tool.
13. DON'T OVERREACH. Keep proper footing and balance at all times.
14. MAINTAIN TOOLS WITH CARE. Keep tools sharp and clean for best and safest performance. Follow instructions for lubricating and changing accessories.
15. DISCONNECT TOOLS before servicing; when changing accessories, such as blades, bits, cutters, and the like.

NAMEPLATE AMPERES (at full load)	EXTENSION CORD LENGTH			
	25'	50'	100'	150'
0 – 6	18	16	16	14
6.1 – 10	18	16	14	12
10.1 – 12	16	16	14	12
12.1 – 16	14	12	Do not use.	

9. USE PROPER EXTENSION CORD. Make sure your extension cord is in good condition. When using an extension cord, be sure to use one heavy enough to carry the current your product will draw. An undersized cord will cause a drop in line voltage resulting in loss of power and overheating. Table A shows the correct size to use depending on cord length and nameplate ampere rating. If in doubt, use the next heavier gauge. The smaller the gauge number, the heavier the cord.
16. REDUCE THE RISK OF UNINTENTIONAL STARTING. Make sure switch is in off position before plugging in.
17. USE RECOMMENDED ACCESSORIES. Consult the owner's manual for recommended accessories. The use of improper accessories may cause risk of injury to persons.
18. NEVER STAND ON TOOL. Serious injury could occur if the tool is tipped or if the cutting tool is unintentionally contacted.
19. CHECK DAMAGED PARTS. Before further use of the tool, a guard or other part that is damaged should be carefully checked to determine that it will operate properly and perform its intended function – check for alignment of moving parts, binding of moving parts, breakage of parts, mounting, and any other conditions that may affect its operation. A guard or other part that is damaged should be properly repaired or replaced.
20. DIRECTION OF FEED. Feed work into a blade or cutter against the direction of rotation of the blade or cutter only.
21. NEVER LEAVE TOOL RUNNING UNATTENDED. TURN POWER OFF. Don't leave tool until it comes to a complete stop.

Grounding Instructions



⚠️ WARNING

TO PREVENT ELECTRIC SHOCK AND DEATH FROM INCORRECT GROUNDING WIRE CONNECTION
READ AND FOLLOW THESE INSTRUCTIONS:

110-120 VAC Double Insulated Tools: Tools with Two Prong Plugs

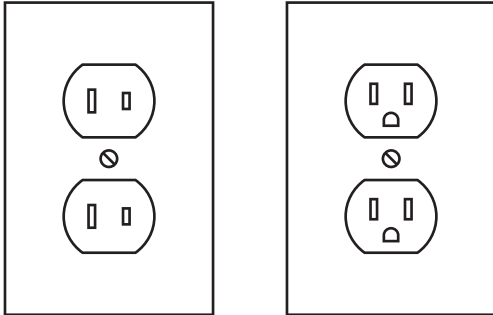

Outlets for 2-Prong Plug

1. To reduce the risk of electric shock, double insulated equipment has a polarized plug (one blade is wider than the other). This plug will fit in a polarized outlet only one way. If the plug does not fit fully in the outlet, reverse the plug. If it still does not fit, contact a qualified electrician to install the proper outlet. Do not change the plug in any way.
2. Double insulated tools may be used in either of the 120 volt outlets shown in the preceding illustration. **(See Outlets for 2-Prong Plug.)**

Miter Saw Safety Warnings

For Your Own Safety Read Instruction Manual Before Operating Miter Saw

1. Wear eye protection.
2. Keep hands out of path of saw blade.
3. Do not operate saw without guards in place.
4. Do not perform any operation freehand.
5. Never reach around saw blade.
6. Turn off tool and wait for saw blade to stop before moving workpiece or changing settings.
7. Disconnect power before changing blade or servicing.
8. Return all guards to original position if any are moved during blade replacement. Check all guards for proper operation after service.
9. Always use blades with correct size and shape (diamond versus round) of arbor holes. Blades that do not match the mounting hardware of the saw will run eccentrically, causing loss of control.
10. Never use damaged or incorrect blade washers or bolt. The blade washers and bolt were specially designed for your saw, for optimum performance and safety of operation.
11. Do not use to cut logs, tree limbs, or uneven lumber.
12. Wet lumber, green (unseasoned) lumber, and pressure treated lumber all have an increased potential for kickback and should only be cut with a blade for cutting that lumber type. Wear a NIOSH-approved respirator and have appropriate ventilation whenever cutting pressure treated lumber.
13. Do not use blades made from high-speed steel, abrasive blades, metal-cutting blades or masonry-cutting blades. The guards of this saw are not designed to protect against the failure of such blades.
14. Blades must be rated to at least the maximum speed marked on the tool.
15. **DO NOT OPERATE WITH ANY GUARD DISABLED, DAMAGED, OR REMOVED. Moving guards must move freely and close instantly.**
16. The use of accessories or attachments not recommended by the manufacturer may result in a risk of injury to persons.
17. When servicing use only identical replacement parts.
18. Do not depress the spindle lock when starting or during operation.
19. Only use safety equipment that has been approved by an appropriate standards agency. Unapproved safety equipment may not provide adequate protection. Eye protection must be ANSI-approved and breathing protection must be NIOSH-approved for the specific hazards in the work area.
20. Stay alert, watch what you are doing and use common sense when operating a power tool. Do not use a power tool while you are tired or under the influence of drugs, alcohol or medication. A moment of inattention while operating power tools may result in serious personal injury.
21. Industrial applications must follow OSHA guidelines.
22. Maintain labels and nameplates on the tool. These carry important safety information. If unreadable or missing, contact Harbor Freight Tools for a replacement.
23. Avoid unintentional starting. Prepare to begin work before turning on the tool.
24. People with pacemakers should consult their physician(s) before use. Electromagnetic fields in close proximity to heart pacemaker could cause pacemaker interference or pacemaker failure.

Miter Saw Safety Warnings (cont.)

- SAFETY**
25. **WARNING:** Some dust created by power sanding, sawing, grinding, drilling, and other construction activities, contains chemicals known [to the State of California] to cause cancer, birth defects or other reproductive harm. Some examples of these chemicals are:
- Lead from lead-based paints
 - Crystalline silica from bricks and cement or other masonry products
 - Arsenic and chromium from chemically treated lumber
- Your risk from these exposures varies, depending on how often you do this type of work. To reduce your exposure to these chemicals: work in a well ventilated area, and work with approved safety equipment, such as those dust masks that are specially designed to filter out microscopic particles. (California Health & Safety Code § 25249.5, *et seq.*)
26. **WARNING:** Handling the cord on this product will expose you to lead, a chemical known to the State of California to cause cancer, and birth defects or other reproductive harm. Wash hands after handling. (California Health & Safety Code § 25249.5, *et seq.*)
27. The warnings, precautions, and instructions discussed in this instruction manual cannot cover all possible conditions and situations that may occur. It must be understood by the operator that common sense and caution are factors which cannot be built into this product, but must be supplied by the operator.

Vibration Safety

- SETUP**
- This tool vibrates during use. Repeated or long-term exposure to vibration may cause temporary or permanent physical injury, particularly to the hands, arms and shoulders. To reduce the risk of vibration-related injury:
- OPERATION**
1. Anyone using vibrating tools regularly or for an extended period should first be examined by a doctor and then have regular medical check-ups to ensure medical problems are not being caused or worsened from use. Pregnant women or people who have impaired blood circulation to the hand, past hand injuries, nervous system disorders, diabetes, or Raynaud's Disease should not use this tool. If you feel any medical or physical symptoms related to vibration (such as tingling, numbness, and white or blue fingers), seek medical advice as soon as possible.
 2. Do not smoke during use. Nicotine reduces the blood supply to the hands and fingers, increasing the risk of vibration-related injury.
 3. Use tools with the lowest vibration when there is a choice between different processes.
 4. Include vibration-free periods each day of work.
 5. Grip tool as lightly as possible (while still keeping safe control of it). Let the tool do the work.
 6. To reduce vibration, maintain the tool as explained in this manual. If any abnormal vibration occurs, stop use immediately.



SAVE THESE INSTRUCTIONS.

**CHICAGO  ELECTRIC®
POWER TOOLS**

Specifications

Motor	120 V~ / 60 Hz / 15 A 5,000 RPM
Arbor Diameter	5/8"
Blade Type	General Purpose with Carbide Tips
Blade Diameter	10"
Cutting Capacity	At 90°: 2-3/4" Deep x 12" Wide. At 45° 1-9/16" Deep x 8-1/4" Wide.
Positive Table Stops	0°, 15°, 22.5°, 30° and 45° Right and Left
Positive Bevel Stops	0° and 45° Left only
Blade Tilt Range	0° - 45° Right and Left Miter 0° - 45° left
Scale	1° per scale mark



List of Contents

Description	Qty
Compound Sliding Miter Saw	1
Carbide Tipped Blade	1
Table Extensions	2
Dust Collection Bag	1
Wrench	1

CHICAGO  ELECTRIC®
POWER TOOLS

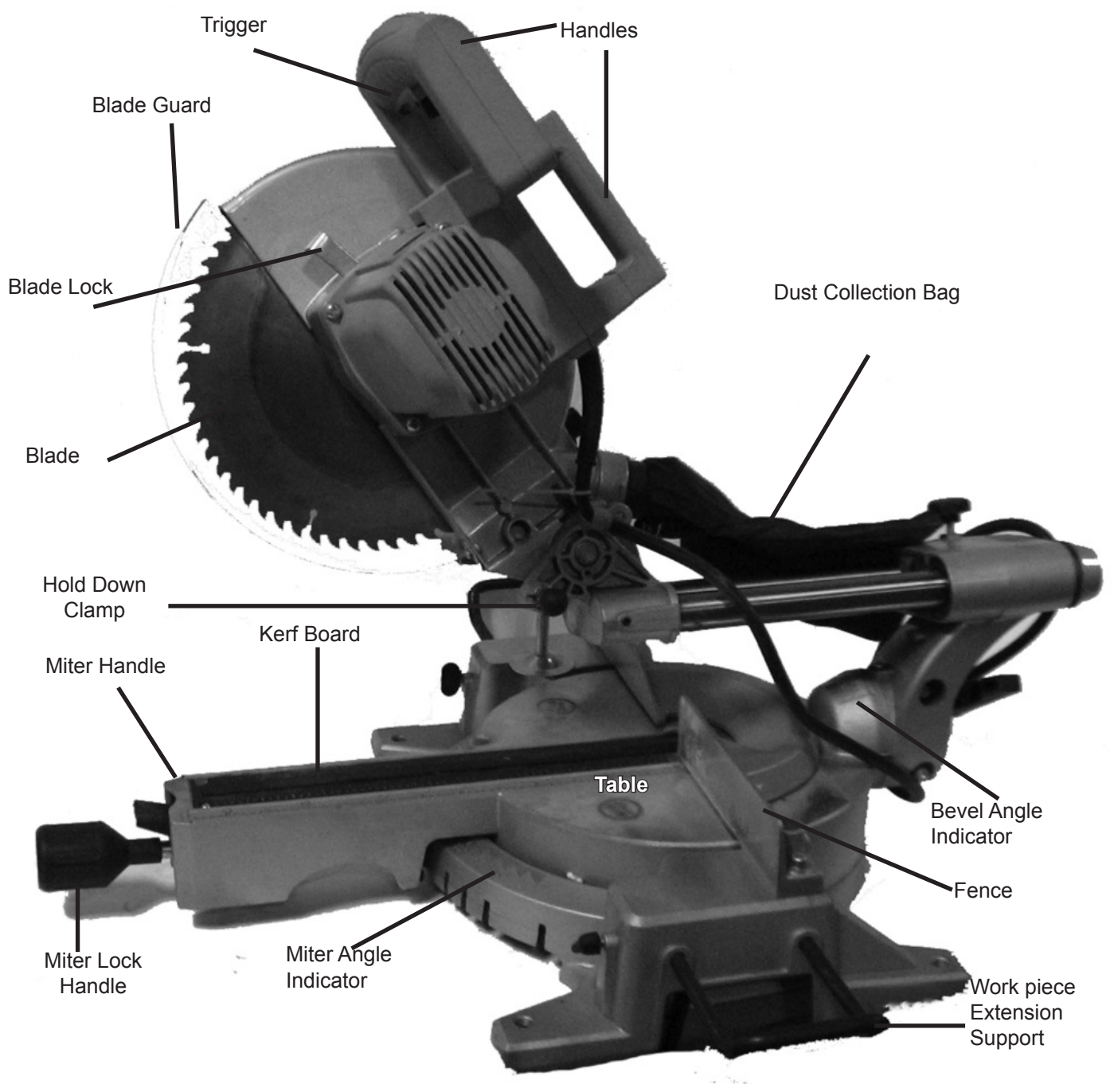

Figure A: Components

CHICAGO  ELECTRIC[®]
POWER TOOLS

Setup - Before Use:



Read the **ENTIRE IMPORTANT SAFETY INFORMATION** section at the beginning of this manual including all text under subheadings therein before set up or use of this product.

WARNING

TO PREVENT SERIOUS INJURY FROM ACCIDENTAL OPERATION:

Turn the Power Switch of the tool to its “OFF” position and unplug the tool from its electrical outlet before assembling or making any adjustments to the tool.

Note: For additional information regarding the parts listed in the following pages, refer to the Assembly Diagram near the end of this manual.

Assembly

Attaching the Extension Supports and Miter Lock Handle

1. Insert the ends of the Extension Supports into the holes in the sides of the Base. Tighten the Wing Screws to hold the Extensions in place. The upper edge of the Extensions will be level with the surface of the saw. This provides a wider base for the work material to rest on.
2. Thread the Miter Lock Handle into the Plate until securely in place.

Attaching the Dust Collection Bag

3. The Dust Collection Bag slips over the Dust Outlet behind the Blade Housing Assembly. Sawdust created by cutting is captured in the bag.

Mounting the Saw

The Miter Saw must be mounted on a support before use. This may be a commercially available support or home made saw table. There are bolt holes provided in each of the four legs of the base. These should be firmly mounted using bolts (not included) to your saw stand or saw table (not included). This will help prevent tipping or movement of the saw, preventing injury. Also, the use of a saw table will make it easier to efficiently handle work materials and make more accurate cuts.

CHICAGO  ELECTRIC[®]
POWER TOOLS

Operating Instructions



Read the **ENTIRE IMPORTANT SAFETY INFORMATION** section at the beginning of this manual including all text under subheadings therein before set up or use of this product.

!WARNING

TO PREVENT SERIOUS INJURY FROM ACCIDENTAL OPERATION:

Unplug power cord from power source before making any adjustments to this tool.

Work Piece and Work Area Set Up

1. Designate a work area that is clean and well-lit. The work area must not allow access by children or pets to prevent injury and distraction.
2. Route the power cord along a safe route to reach the work area without creating a tripping hazard or exposing the power cord to possible damage. The power cord must reach the work area with enough extra length to allow free movement while working.
3. Use a saw table, saw stand or other means to support the work piece. The Miter Saw must be mounted in such a way that the surface is level to the ground, and supports used must provide a surface on the same level as the saw table. If the work surface and any work materials supports are not level, and on the same level, unwanted bevel angles will appear in the cuts resulting in poor joinery.
4. Work pieces may be secured to the saw table using the Hold Down Clamp or other clamping devices (not included). Securing the work piece will provide safety by preventing kick back and by removing the need to hold work pieces near the blade by hand. Clamping the work piece will also improve cutting accuracy by preventing the work piece from moving during the cutting operation.
5. When using this saw, work pieces are often quite long. Allow room on both left and right of saw for extended work pieces.

CHICAGO  ELECTRIC[®]
POWER TOOLS

TOOL SET UP

Using the Work Piece Extension Supports

1. The Work Piece Extension Supports are inserted into each side of the Table, and locked in place using the Wing Screws.
2. When properly installed, the upper face of the Work Piece Extension Supports are level with the Table, and provide a wider support surface for the work piece.
3. Always support the work piece to be level with the table, and so that after the cut is made the cut off pieces will not fall. You may need to use saw horses or other supports (not included) to support the work piece.
4. If the work piece is not level, you will make an unintentional bevel cut in the material. If the work piece is not supported, it will bind the blade and may cause the material to kick back, potentially causing injury.

Adjusting the Miter Angle

1. A miter cut is one that is at an angle across the horizontal surface of the material. You will commonly make 45° miter cuts to join two pieces in a right angle corner. A 30° cut is often used for a scarf joint or to make a chamfered end.
2. To make a miter cut, loosen the Miter Lock Knob by turning it approximately 1/4 turn counterclockwise. Press down the Thumb Lever to unlock the Table. While holding the Thumb Lever down, move the Table to the desired angle. The Miter Angle Indicator will indicate the selected angle. The table will lock into place at often used miter angles, including 22.5°, 30°, 45°, and 90° on both left and right sides.
3. With the Table adjusted to the desired angle, place the work piece flush against the Fence, secure it with the Hold Down Clamp and make the cut.

Adjusting the Bevel Angle

1. A bevel cut is one that is at an angle to the vertical plane of the material.
2. Bevel cuts can be used to miter relatively wide and thin material. Bevel cuts can be used in combination with a miter cut to form a compound angle. Compound angle cuts are often used in crown moldings, picture frames and similar trim materials.
3. To set the bevel angle, loosen the Bevel Lock Handle at the rear of the saw. To do this, press in the Lock Button and rotate the Handle 1/2 turn counterclockwise. Move the blade assembly left to the desired angle. You can read the angle on the Bevel Angle Indicator. Lock the blade assembly into position by pressing in the Lock Button and rotating the Bevel Lock Handle clockwise. Tighten firmly but not over-tight.
4. Make a sample cut in a piece of scrap and check to be sure the bevel angle is correct. If it is not, correct the angle before cutting your work material.

Using the Depth Stop

1. If you want to make a kerfing or rabbet cut which does not cut through the work piece, you can use the Depth Stop Screw to control the depth of the cut.
2. To limit blade assembly travel, turn the Depth Stop Screw clockwise. The further you screw down the Depth Stop Screw, the shallower the cut will be.
3. After the desired cut has been made, return the Depth Stop Screw to its open position by turning it counterclockwise.

General Operating Instructions

1. When the Handle is lowered, the Blade Guard raises automatically. When the Handle is raised the Blade Guard returns to its safety position. Keep hands clear of the Blade when the Handle is lowered. Never interfere with the proper movement of the Blade Guard.
2. There are locking mechanisms for the miter angle and the Slides. Unlock the Table to set the miter angle, then re-lock it before making the cut. Unlock the Slide using the Slide Lock Wing Screw before making a cut if the work material is too wide to “chop”.
3. To rotate the Table, press down the Miter Thumb Lever, rotate the Table to the desired angle, then release the Miter Lock Lever. Notches are machined into the Base of the tool which will lock the Table into several often used miter angles. These angles are 0° (centered), 15°, 22.5°, 30° and 45° both left and right cut.
4. On wider pieces, you will have to slide the blade while making the cut. To unlock the Slide, loosen the Slide Lock Wing Screw at the back of the saw.
5. To make a bevel cut, release the Bevel Lock Lever, rotate the blade assembly to the desired bevel angle, then lock the blade assembly in place using the Bevel Lock Lever. Making bevel cuts is discussed in more detail later in this manual.
6. This saw is provided with a Kerf Board. The Kerf Board helps to prevent tear-out on the bottom side of the work material. The Kerf Board is factory adjusted prior to shipment of this tool so the blade does not contact the Kerf Board during normal operation, including bevel cuts. Adjustment of the Kerf Board and techniques to prevent tear-out are discussed later in this booklet.
7. Before starting work, check the accuracy of the Guide Fence, miter angle and bevel angle. Instructions for checking and adjusting these angles are discussed later in this booklet.
8. It is very important that the work material be properly supported before making a cut. The material must be level on the Table. The material must be supported on both ends. Using the Work Piece Extension Supports is discussed in the next section.
9. Use this saw only for its intended purpose of cutting flat rectangular or round wood stock, or finished molding. Do not use it for cutting firewood, brush, or anything that does not lie flat on the table. Doing so may cause binding or violent kick-back that may result in damage or personal injury.

Making a Cut

1. Observe all safety and planning items discussed in this booklet. Detailed instructions on each of the following steps are discussed in this booklet. Do not make any cuts until you have read this entire booklet and are familiar with the operation of this tool.
2. Release the Locking Pin to allow the blade assembly to come up. Check to be sure the Table is fixed in place at the desired miter angle. Check to be sure the slide lock is released to allow the blade assembly to slide freely.
3. Blow any sawdust or debris away from the Fence. Place the work material against the Fence.
4. Make any necessary miter or bevel adjustments.
5. Align the marked location of the cut on the work material with the saw blade. Be aware that the Saw Blade will remove material from the cut equal to the width of the blade. This is the “kerf”. To prevent your work piece from being cut too short, align the edge of the blade with your measured mark, keeping the kerf on the waste side of the cut.
6. Hold the work material in place using the Hold Down Vise. Ensure that the work material is level and supported securely, using saw horses or supports if necessary.
7. Grip the Saw Handle and squeeze the Trigger to start the Blade turning.
8. Pressing down lightly, move the Blade smoothly across the work material to cut it. With narrow material, you can press straight down “chopping” the material. With wider material you must move the Blade across the material to cut it. Do not bear down on the material, use light downward pressure. If the material binds the blade, release the trigger. Keep your hands away from the Blade.
9. When the cut is completed, raise the blade assembly, wait for the Blade to stop turning, release the Hold Down Vise and remove the work material from the saw.

Maintenance and Servicing



Procedures not specifically explained in this manual must be performed only by a qualified technician.

!WARNING

TO PREVENT SERIOUS INJURY FROM ACCIDENTAL OPERATION:

Turn the Power Switch of the tool to its “OFF” position and unplug the tool from its electrical outlet before performing any inspection, maintenance, or cleaning procedures.

TO PREVENT SERIOUS INJURY FROM TOOL FAILURE:

Do not use damaged equipment. If abnormal noise or vibration occurs, have the problem corrected before further use.

Cleaning, Maintenance, and Lubrication

1. **BEFORE EACH USE**, inspect the general condition of the tool. Check for loose screws, misalignment or binding of moving parts, cracked or broken parts, damaged electrical wiring, and any other condition that may affect its safe operation.
2. **AFTER USE**, clean external surfaces of the tool with clean, moist cloth. To prevent accidents, turn off the tool and disconnect its power supply after use. Clean, then store the tool indoors out of children’s reach.
3. If the blade has become dirty, use a blade cleaner (not included) to clean it. Dirty blades will bind more easily, and will more often overheat and burn the wood as it cuts. Overheated blades dull more easily.
4. If the Blade has become dull, replace it. Dull blades will cause increased tear-out and ragged edges on the cuts.
5. Occasionally clean the Slides, rotating Table components and other moving parts. Use a good quality dry lubricant (not included) which will not attract dust.
6. Observe the Dust Bag while using the saw. Empty the sawdust into an appropriate container when the bag is full.
7. Occasionally wipe or blow off sawdust that accumulates on the saw. Saw dust on the Fence can cause you to make inaccurate cuts.
8. Keep the Slides free of sawdust. Wipe or blow them off as required. Use a dry lubricant or wax on the slides. Do not use an oil or grease lubricant, as this will attract dust.
9. Occasionally lubricate the pivot point of the Table as well as other moving parts with a dry lubricant.
10. **!WARNING!** If the supply cord of this power tool is damaged, it must be replaced only by a qualified service technician.

CHICAGO  ELECTRIC[®]
POWER TOOLS

Replacing the Blade

⚠ WARNING

TO REDUCE RISK OF SERIOUS INJURY:

Return guard to original position and secure in place after replacing blade.

1. Unplug the tool from its power source.
2. Lock the blade assembly in the raised position by pushing in the Locking Pin.
3. Use the supplied Wrench to remove the Center Cover Fixing Bolt holding the Center Cover in place by turning it counterclockwise. (See Figure B.)
6. While holding in the Arbor Lock Button, use the Wrench to loosen the Arbor Bolt by turning it clockwise. (See Figure E.)



Figure B: Removing Bolt

4. Remove the Safety Screw. (See Figure C.)



Figure C: Removing Safety Screw

5. Raise the Blade Guard and Center Cover. (See Figure D.)



Figure D: Raise Blade Guard



Figure E: Arbor Bolt

Note: The Arbor Bolt has a left hand thread, so it loosens by turning clockwise.

7. Remove the Arbor Bolt, Outer Flange and Saw Blade by pulling them straight off the Arbor.
8. Reinstall a new Blade on the Arbor. (See Figure F.) Be sure to match the direction marked on the new blade with the direction marked on the saw Blade Housing.

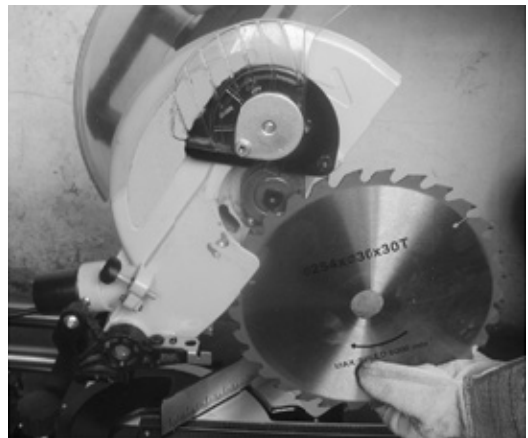

Figure F: Removing Blade

9. Replace the Outer Flange and Arbor Bolt. Tighten the Arbor Bolt securely using the Wrench by turning it counterclockwise.
10. Rotate the Center Cover back into place and tighten the Center Cover Fixing Bolt using the Wrench by turning it clockwise.
11. Release the Locking Pin.

Adjusting the Fence

The Fence holds the work piece in a fixed position while the Table and or the blade assembly are adjusted in a miter or bevel angle.

To make accurate cuts, the Fence must be perpendicular (at a 90° angle) to the Saw Blade.

1. Before beginning work, make a test cut on scrap material with the Table set at 90°.
2. Check the cut with an accurate square. You can also reverse the two pieces, hold the cut ends together, and hold a good straight edge along the side of the pieces.
3. If either test reveals that the cut is not a true 90° angle, you must adjust the Fence before beginning work.

If Fence needs adjustment:

1. First unplug the tool.
2. Lower the blade assembly and lock it in place using the Locking Pin.
3. Lay a carpenter's square on the table with one edge along the blade and the other along the Fence. Any inaccuracy should be visible. NOTE: The square must contact the surface of the blade, not the teeth, for an accurate reading.
4. The Fence is held in place with bolts at each end. Loosen the bolts slightly, and gently tap the Fence into position using a soft mallet. Retighten the bolts and make another test cut. Repeat the process until the Fence is adjusted accurately.
5. Once the Fence is accurately adjusted, tighten the bolts firmly in place. Recheck one last time, then proceed to work.

Adjusting the Miter Table Indicator

1. After you have checked or adjusted the fence to be sure it is at 90° to the Blade, check the accuracy of the Miter Table Angle Indicator.
2. Loosen the screw holding the Angle Indicator in place.
3. Rotate it until the pointer is exactly on 90°.
4. Retighten the screw.

Adjusting the Bevel Angle

For making accurate cuts, the Saw Blade must be adjusted to be exactly vertical to the Table.

1. To check the angle, have the blade assembly in its normal upright position. Make a cut on a piece of flat sided, fairly thick scrap material.
2. Check the cut with an accurate square. The cut should be at exactly 90°. You can also check by rotating one cut-off piece 180° and hold the cut ends together. If the cut is not exactly vertical, the two pieces will form a slight angle.
3. If necessary, the bevel angle can be corrected by adjusting the Bevel Adjustment Screw on the right side under the Bevel Locking Lever.
4. Once the bevel angle is adjusted, adjust the Bevel Angle Indicator to read 0° when the Saw Blade is in the vertical position. Loosen the screw holding the Indicator in place, adjust it to be exactly over the 0° mark, then retighten the screw.

Adjusting or Replacing the Kerf Board

If the Kerf Board becomes damaged it must be replaced.

1. Remove the four screws holding the Kerf Board in place.
2. Install a new Kerf Board. Replace the four screws and tighten them slightly.
3. To adjust the Kerf Board, lower the Saw Blade and lock it down with the Locking Pin. Adjust the Kerf Board so the right side of the Blade slightly clears the edge of the Kerf Board. Loosen the Bevel Lock and set the Bevel Angle at 45° left. Ensure that the left side of the Blade clears the Kerf Board. Tighten the four screws holding the Kerf Board in place.

Troubleshooting

Problem	Possible Causes	Likely Solutions
Tool will not start	<ol style="list-style-type: none"> 1. No power at outlet. 2. Cord not connected. 	<ol style="list-style-type: none"> 1. Check power at outlet. 2. Check that cord is plugged in.
Tool operates sporadically or at low power	<ol style="list-style-type: none"> 1. Low power supply or improper extension cords. 2. Worn or cracked Carbon Brushes. 	<ol style="list-style-type: none"> 1. Check power supply and power cords. 2. Check Carbon Brushes. Replace if damaged or worn.
Wood burns at ends when cut	<ol style="list-style-type: none"> 1. Dirty Blade. 2. Material is binding. 	<ol style="list-style-type: none"> 1. Clean Blade using blade cleaner or mineral spirits. 2. Check position of work material on Table. Material must be flat, flush against Fence and supported on ends.
Material frays or chips out.	<ol style="list-style-type: none"> 1. Finished side is down 2. Blade chipped or dull. 3. Blade inappropriate for material. 4. Material is unsupported. 	<ol style="list-style-type: none"> 1. Keep finished side of material up or facing operator. Bottom and back side are prone to chip out. 2. Check for damaged teeth. Sharpen or replace blade. 3. Check blade manufacturer's recommendations for material being cut. For cross cutting hard wood and for precision cuts use a thin kerf blade with 60 or more teeth. 4. Use a thin piece of scrap material, such as 1/4" plywood, underneath or behind the material to support the edges of the material as it is being cut.
Blade binds, slowing or stopping saw.	<ol style="list-style-type: none"> 1. Material is misaligned on the saw or ends are not supported. 2. Material is wet, contaminated or inappropriate blade is being used. 	<ol style="list-style-type: none"> 1. Material must be flat on table, flush against the fence and supported on both ends. 2. Check condition of material and check compatibility of blade to material.



Follow all safety precautions whenever diagnosing or servicing the tool. Disconnect power supply before service.

PLEASE READ THE FOLLOWING CAREFULLY

THE MANUFACTURER AND/OR DISTRIBUTOR HAS PROVIDED THE PARTS LIST AND ASSEMBLY DIAGRAM IN THIS MANUAL AS A REFERENCE TOOL ONLY. NEITHER THE MANUFACTURER OR DISTRIBUTOR MAKES ANY REPRESENTATION OR WARRANTY OF ANY KIND TO THE BUYER THAT HE OR SHE IS QUALIFIED TO MAKE ANY REPAIRS TO THE PRODUCT, OR THAT HE OR SHE IS QUALIFIED TO REPLACE ANY PARTS OF THE PRODUCT. IN FACT, THE MANUFACTURER AND/OR DISTRIBUTOR EXPRESSLY STATES THAT ALL REPAIRS AND PARTS REPLACEMENTS SHOULD BE UNDERTAKEN BY CERTIFIED AND LICENSED TECHNICIANS, AND NOT BY THE BUYER. THE BUYER ASSUMES ALL RISK AND LIABILITY ARISING OUT OF HIS OR HER REPAIRS TO THE ORIGINAL PRODUCT OR REPLACEMENT PARTS THERETO, OR ARISING OUT OF HIS OR HER INSTALLATION OF REPLACEMENT PARTS THERETO.

CHICAGO  ELECTRIC[®]
POWER TOOLS

Parts List and Diagram

Parts List

Part	Description	Qty
1	Bolt M6X25	2
2	Base	1
3	Extension Arm	2
4	Screw	2
5	Feet	4
6	Bolt M8X50	1
7	Bolt M5X10	4
8	Spring Washer	8
9	Flat Washer	4
10	Plate	1
11	Rub Slice	1
12	Pin	1
13	Spring	1
14	Pin 3X20	1
15	Handle	1
16	Plate	1
17	Pin	1
18	Pointer	1
19	Bolt M4X12	2
20	Bolt M4X8	9
21	Kerf	1
22	Plate	1
23	Plate	1
24	Bolt M8X30	1
25	Table	1
26	Flat Washer	1
27	Lock Nut	1
28	Rail	1
29	Flat Washer	8
30	Spring Washer	8
31	Bolt M6X30	4
32	Screw	1
33	Clamp	1
33	Screw	1
34	Bolt	1
35	Flat Washer	1
36	Pointer	1
37	Nut	2
38	Spring	1
39	Bend Arm	1
40	Flat Washer	2
41	Lock Nut	1
42	Washer	2

Part	Description	Qty
43	Bolt	1
44	Lock Handle	1
45	Lock Pin Spring	1
46	Bolt	1
47	Bolt M5X14	2
49	Oil Cover	2
50	Bearing	2
51	Rod	2
52	Mount	1
53	Line Button	2
54	Washer	2
55	Bolt M6X10	4
56	Limit Plate	1
57	Slide Lock Wing Screw	1
58	Handle Ball	1
59	Lock Spring	1
60	Lock Pin	1
61	Spring Pin	1
62	Cover Stand	1
63	Screw	1
64	Bolt	1
65	Washer	2
66	Lock Button	1
67	Link Pole Bolt	2
68	Link Pole	1
69	Brush Cover	2
70	Carbon Brush	4
71	Brush House	2
72	Motor House	1
73	Bolt	4
74	Brush House Spring	2
75	Stator	1
76	Screw	2
77	Block Circle	1
78	Bearing	1
79	Rotor	1
80	Bearing	1
81	Lock Button	1
82	Lock Button Spring	1
83	Spring Washer	2
84	Block Plate	1
85	Spring	1

Part	Description	Qty
86	Pin	1
87	Cover	1
88	Bolt M6X10	1
89	Bolt M6X20	2
90	Dust Pipe	1
91	Dust Collector	1
92	Screw	1
93	Lock Washer	2
94	Bearing	1
95	Spring Washer	1
96	Gear	1
97	Front Cover	1
98	Bearing	1
99	Output Axis	1
100	Key 4X13	1
101	Bearing Cover	1
102	Bolt	3
103	Inner Flange	1
104	Blade	1
105	Outer Flange	1
106	Screw M8X20 Left	1
107	Lock Nut	1
108	Small Cover	1
109	Large Cover	1
110	Washer	1
111	Bolt	1
112	Bolt M8X12	1
113	Spring	1
114	Blade Cover	1
115	Link Pole Plank	1
116	Switch	1
117	Bolt	2
118	Handle	1
119	Bolt	2
120	Bolt	2
121	Handle	1
122	Bolt	2
123	Press Plank	1
124	Power Wire	1
125	Rubber sheath	1
126	Handle	1
127	Spanner	1
128	Bearing	1

REV 11a

Assembly Diagram

SAFETY

SETUP

OPERATION

MAINTENANCE

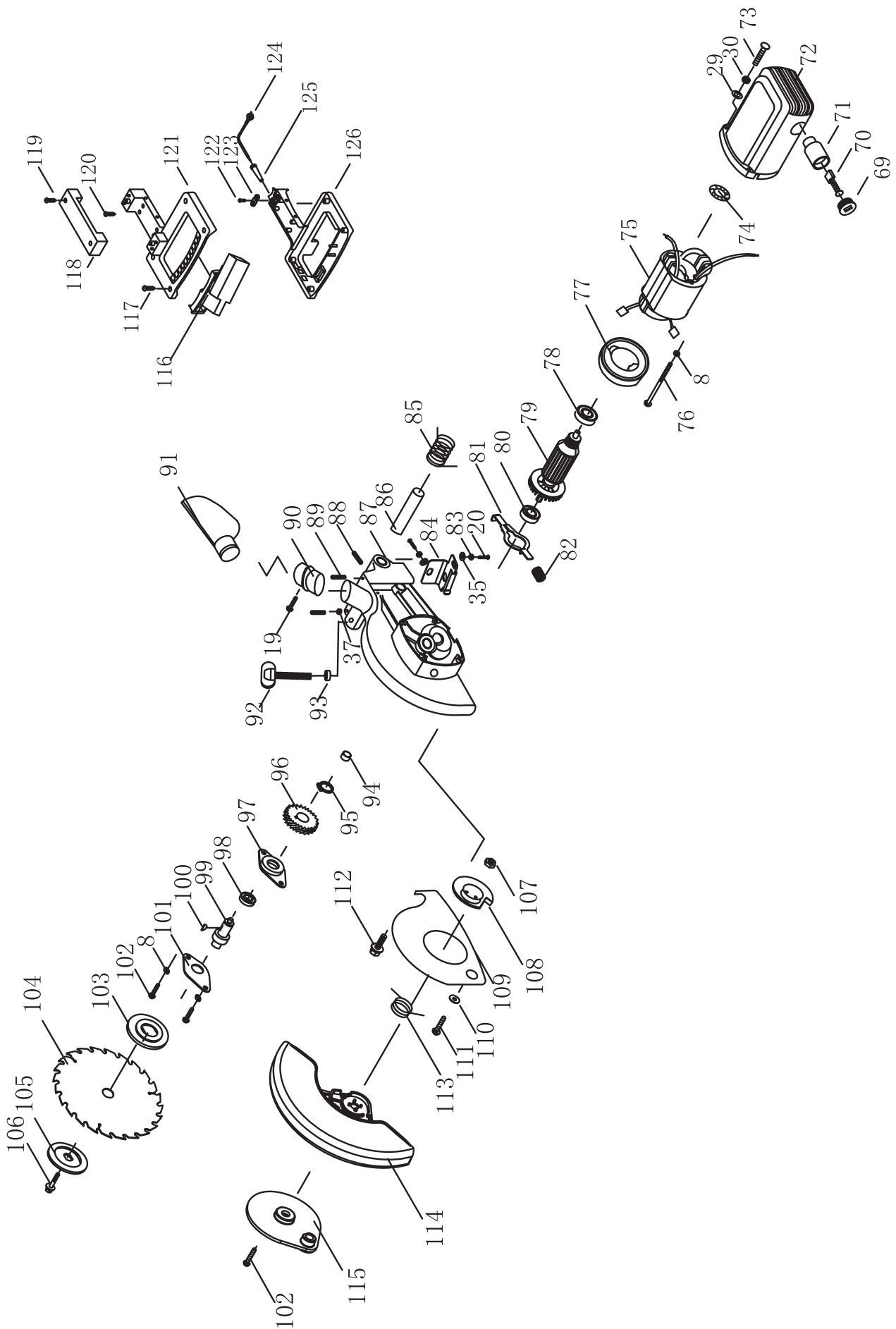

Assembly Diagram (cont.)

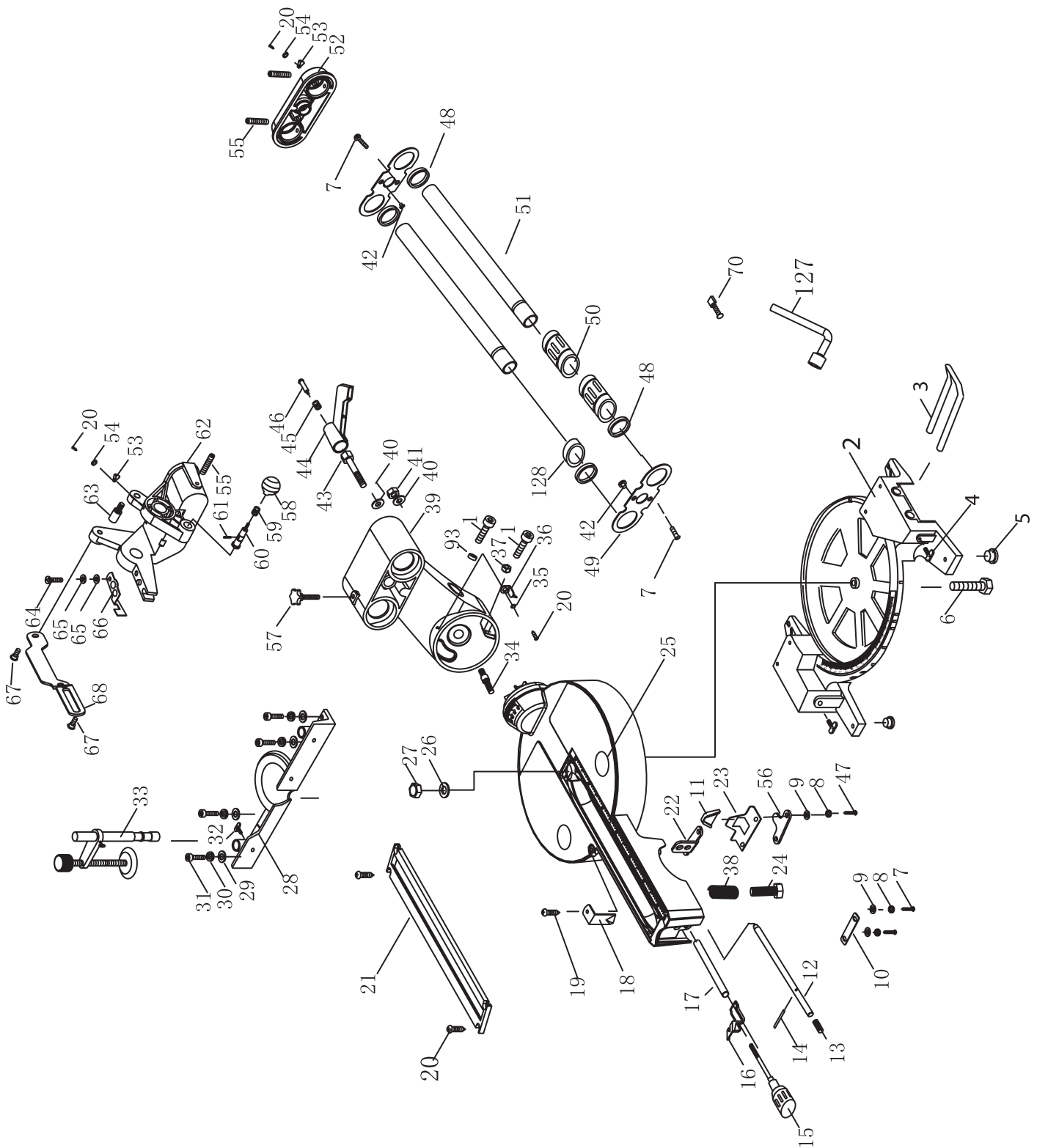

Record Product's Serial Number Here: _____

Note: If product has no serial number, record month and year of purchase instead.

Note: Some parts are listed and shown for illustration purposes only, and are not available individually as replacement parts.

Limited 90 Day Warranty

Harbor Freight Tools Co. makes every effort to assure that its products meet high quality and durability standards, and warrants to the original purchaser that this product is free from defects in materials and workmanship for the period of 90 days from the date of purchase. This warranty does not apply to damage due directly or indirectly, to misuse, abuse, negligence or accidents, repairs or alterations outside our facilities, criminal activity, improper installation, normal wear and tear, or to lack of maintenance. We shall in no event be liable for death, injuries to persons or property, or for incidental, contingent, special or consequential damages arising from the use of our product. Some states do not allow the exclusion or limitation of incidental or consequential damages, so the above limitation of exclusion may not apply to you. THIS WARRANTY IS EXPRESSLY IN LIEU OF ALL OTHER WARRANTIES, EXPRESS OR IMPLIED, INCLUDING THE WARRANTIES OF MERCHANTABILITY AND FITNESS.

To take advantage of this warranty, the product or part must be returned to us with transportation charges prepaid. Proof of purchase date and an explanation of the complaint must accompany the merchandise. If our inspection verifies the defect, we will either repair or replace the product at our election or we may elect to refund the purchase price if we cannot readily and quickly provide you with a replacement. We will return repaired products at our expense, but if we determine there is no defect, or that the defect resulted from causes not within the scope of our warranty, then you must bear the cost of returning the product.

This warranty gives you specific legal rights and you may also have other rights which vary from state to state.

CHICAGO  ELECTRIC®
POWER TOOLS

3491 Mission Oaks Blvd. • PO Box 6009 • Camarillo, CA 93011 • 1-888-866-5797