

# Owner's Manual & Safety Instructions

**Save This Manual** Keep this manual for the safety warnings and precautions, assembly, operating, inspection, maintenance and cleaning procedures. Write the product's serial number in the back of the manual near the assembly diagram (or month and year of purchase if product has no number). Keep this manual and the receipt in a safe and dry place for future reference.

**PITTSBURGH<sup>®</sup> AUTOMOTIVE**

**ITEM 60827**

## **2WD and 4WD Ball Joint Service Kit**



Visit our website at: <http://www.harborfreight.com>  
Email our technical support at: [tech@harborfreight.com](mailto:tech@harborfreight.com)





When unpacking, make sure that the product is intact and undamaged. If any parts are missing or broken, please call 1-800-444-3353 as soon as possible.

Copyright© 2012 by Harbor Freight Tools®. All rights reserved.  
No portion of this manual or any artwork contained herein may be reproduced in any shape or form without the express written consent of Harbor Freight Tools. Diagrams within this manual may not be drawn proportionally. Due to continuing improvements, actual product may differ slightly from the product described herein. Tools required for assembly and service may not be included.

### **⚠ WARNING**

**Read this material before using this product.  
Failure to do so can result in serious injury.  
SAVE THIS MANUAL.**

## WARNING SYMBOLS AND DEFINITIONS

	This is the safety alert symbol. It is used to alert you to potential personal injury hazards. Obey all safety messages that follow this symbol to avoid possible injury or death.
	Indicates a hazardous situation which, if not avoided, will result in death or serious injury.
	Indicates a hazardous situation which, if not avoided, could result in death or serious injury.
	Indicates a hazardous situation which, if not avoided, could result in minor or moderate injury.
	Addresses practices not related to personal injury.

## IMPORTANT SAFETY INFORMATION



**WARNING** Read all safety warnings and instructions.

*Failure to follow the warnings and instructions may result in serious injury.*

**Save all warnings and instructions for future reference.**

1. **Keep children and bystanders away while operating.**  
Distractions can cause you to lose control.
2. Keep work area clean and well lit.  
Cluttered or dark areas invite accidents.
3. **Wear ANSI-approved safety goggles, NIOSH-approved dust mask/respirator, and heavy-duty work gloves during use and service.**
4. Stay alert and use common sense when operating.  
Do not use when tired or under the influence of drugs, alcohol or medication.
5. Do not overreach. Keep proper footing and balance at all times. This enables better control in unexpected situations.
6. Dress properly. Do not wear loose clothing or jewelry. Keep your hair, clothing and gloves away from moving parts. Loose clothes, jewelry or long hair can be caught in moving parts.
7. **This product is not a toy. Keep it out of reach of children.**
8. Use the correct product for the correct vehicle.  
The correct product will do the job better and safer at the rate for which it was designed.  
Do not modify this product or use it for a purpose for which it is not intended.
9. Check for misalignment or binding of moving parts, breakage of parts and any other condition that may affect the product's operation. If damaged, have the product repaired before use.
10. Use the product and accessories etc., in accordance with these instructions and in the manner intended for the particular type of product, taking into account the working conditions and the work to be performed. Use of the product for operations different from those intended could result in a hazardous situation.
11. Have product serviced by a qualified repair person using only identical replacement parts. This will ensure that the safety of the product is maintained.
12. Maintain labels and nameplates on the product. These carry important safety information. If unreadable or missing, contact Harbor Freight Tools for a replacement.
13. This product contains or, when used, produces a chemical known to the State of California to cause cancer and birth defects or other reproductive harm. (California Health & Safety Code § 25249.5, *et seq.*)
14. Use caution when applying a load. Slowly and carefully apply pressure to the vehicle part being pressed. If the workpiece seems unusually hard to press, immediately stop the operation. Carefully disconnect the Ball Joint Kit from the workpiece, and adjust the Ball Joint Kit to eliminate or diminish an off-center load. Then, continue with the procedure.

15. Do not use the Ball Joint Kit to compress springs or any other item that could disengage and cause a potential hazard.
16. Do not allow any lubricants to make contact between any part of the Ball Joint Kit and the part being pressed. Lubricants of any type on the above mentioned parts will diminish the ability of the Ball Joint Kit to firmly and safely grip and hold the Ball Joint Kit in position.
17. Examine the Ball Joint Kit for structural cracks, bends, and any other condition that may affect the safe operation of the tool. Do not use the Ball Joint Kit even if minor damage appears.
18. Read and understand all instructions and safety precautions as outlined in the manufacturer's manual for the vehicle you are servicing. Use the vehicle manufacturer's recommended ball joint press points.
19. The warnings, precautions, and instructions discussed in this instruction manual cannot cover all possible conditions and situations that may occur. It must be understood by the operator that common sense and caution are factors which cannot be built into this product, but must be supplied by the operator.



## SAVE THESE INSTRUCTIONS.

### Operating Instructions



Read the **ENTIRE WARNING** section at the beginning of this manual including all text under subheadings therein before set up or use of this product.

**Note:** Read vehicle service manual to determine how to prepare the ball joint for removal from a specific vehicle make/model. The generic instructions that follow may, or may not apply to your vehicle.

### To Remove a Ball Joint

1. Assemble the Ball Joint Press (1) over the vehicle's control arm. Select the correct size Receiving Tube (3, 4, or 5), and position it under the vehicle's ball joint.
2. Place the Removal Adapter (7) between the Receiving Tube and the Jackscrew (2).
3. Then, place the Installation Adapter (6) between the top of the ball joint and the Ball Joint Press. See Figure A.
4. Tighten the Jackscrew until the Receiving Tube contacts the vehicle's control arm.
5. Check the alignment of all the Ball Joint Kit parts, and continue tightening the Jackscrew until the vehicle's ball joint is removed.

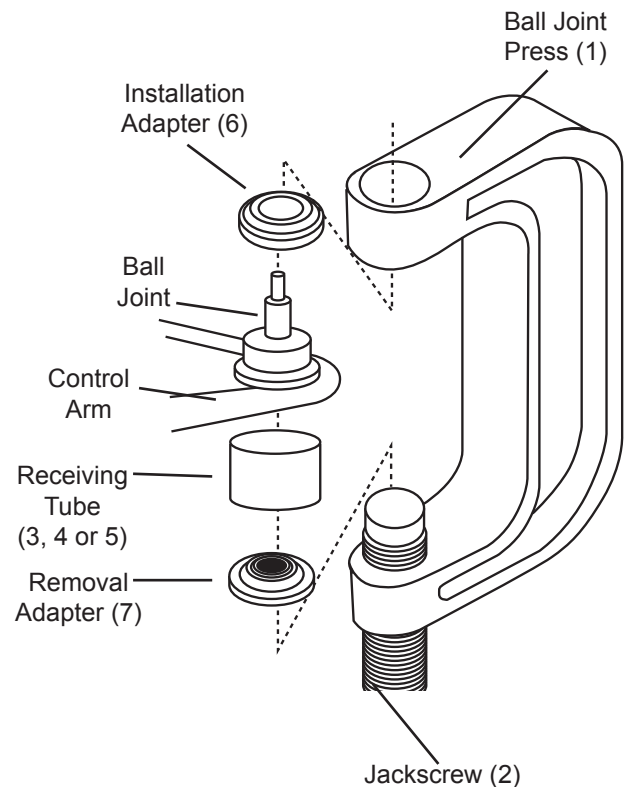
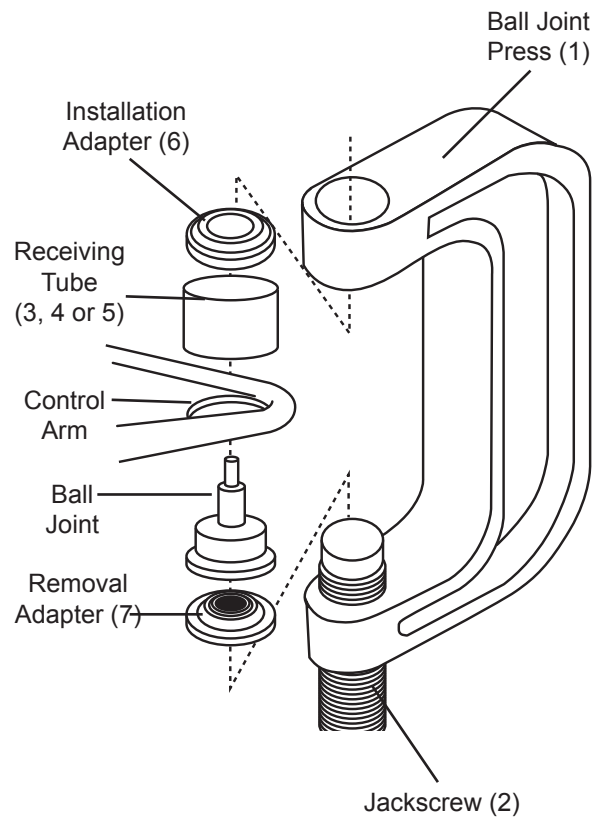

Figure A

## To Install a Ball Joint

1. Clean the vehicle's control arm, and coat the inside diameter of the control arm with a light lubricant.
2. Insert the replacement ball joint as straight as possible into the vehicle's control arm.
3. Assemble the Ball Joint Press over the vehicle's control arm. Select the correct size Receiving Tube and position it on top of the vehicle's control arm. See Figure B.
4. Place the Installation Adapter between the Receiving Tube and the Ball Joint Press. Then, place the Removal Adapter between the ball joint and the Jackscrew.
5. Check the alignment of all the Ball Joint Kit parts. Then, tighten the Jackscrew until the vehicle's ball joint is firmly sealed.



**Figure B**

## To Remove and Install Brake Anchor Pins

1. To remove the brake anchor pins, remove all lock ring retainers from the Brake Anchor Pins.
2. Position the Ball Joint Press over the brake spider.
3. Tighten the Jackscrew until the anchor pins can be removed. See Figure C.
4. To install the brake anchor pins, insert the brake anchor pins. Then reinstall the lock ring retainers on the brake anchor pin.
5. Unscrew and remove the Ball Joint Press.

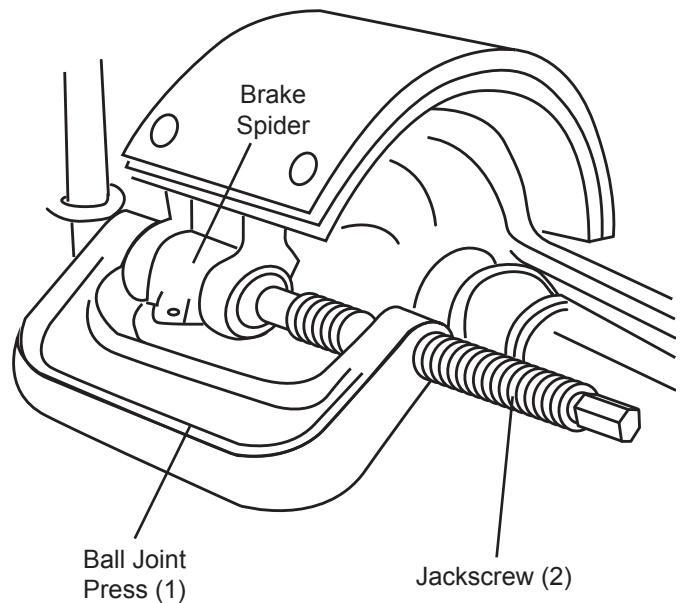

**Figure C**

## To Disassemble / Assemble a "U" Joint

---

1. To disassemble a "U" joint, remove any external and/or internal lock rings.
2. Position the Ball Joint Press around the drive shaft yoke and tighten the Jackscrew until the first bearing is removed. See Figure D.
3. Reposition the Ball Joint Press and remove the second bearing.
4. To assemble a "U" joint, clean all dirt and oil from the yoke area.
5. Align the replacement bearing and Ball Joint Press as straight as possible over the yoke. Press the replacement bearing into the yoke, and reassemble the external/internal lock ring.
6. Reposition the Ball Joint Press and second replacement bearing as straight as possible over the yoke, and press the bearing into the yoke.
7. Reassemble the external/internal lock ring.

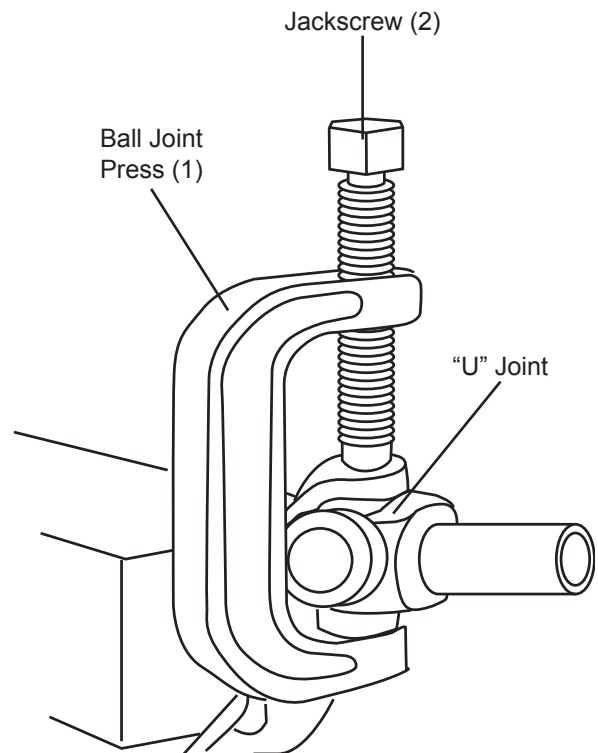

Figure D

**PITTSBURGH<sup>®</sup> AUTOMOTIVE**

## Cleaning, Maintenance, and Lubrication

Do not perform any inspection, maintenance or cleaning procedures with the Ball Joint Kit is under a load.

1. **BEFORE EACH USE**, inspect the general condition of the Ball Joint Kit. Check for misalignment or binding of moving parts, cracked or broken parts, and any other condition that may affect its safe operation. If abnormal noise or vibration occurs, have the problem corrected before further use. **Do not use damaged equipment.**
2. **PERIODICALLY**, use a premium quality and light weight machine oil to lubricate the threads of the Jackscrew.
3. **AFTER USE**, wipe clean with a damp cloth, using a mild detergent or mild solvent.
4. When storing, keep Ball Joint Kit in its Carrying Case (11).

## PLEASE READ THE FOLLOWING CAREFULLY

---

THE MANUFACTURER AND/OR DISTRIBUTOR HAS PROVIDED THE PARTS LIST AND ASSEMBLY DIAGRAM IN THIS MANUAL AS A REFERENCE TOOL ONLY. NEITHER THE MANUFACTURER OR DISTRIBUTOR MAKES ANY REPRESENTATION OR WARRANTY OF ANY KIND TO THE BUYER THAT HE OR SHE IS QUALIFIED TO MAKE ANY REPAIRS TO THE PRODUCT, OR THAT HE OR SHE IS QUALIFIED TO REPLACE ANY PARTS OF THE PRODUCT. IN FACT, THE MANUFACTURER AND/OR DISTRIBUTOR EXPRESSLY STATES THAT ALL REPAIRS AND PARTS REPLACEMENTS SHOULD BE UNDERTAKEN BY CERTIFIED AND LICENSED TECHNICIANS, AND NOT BY THE BUYER. THE BUYER ASSUMES ALL RISK AND LIABILITY ARISING OUT OF HIS OR HER REPAIRS TO THE ORIGINAL PRODUCT OR REPLACEMENT PARTS THERETO, OR ARISING OUT OF HIS OR HER INSTALLATION OF REPLACEMENT PARTS THERETO.

## Parts List & Assembly Diagram

Part	Description	Qty
1	Ball Joint Press	1
2	Jackscrew	1
3	Receiving Tube (2-1/4" L x 2.723" I.D. x 3" O.D.)	1
4	Receiving Tube (1-3/4" L x 2-1/4" I.D. x 2-1/2" O.D.)	1
5	Receiving Tube (1-3/4" L x 1-3/4" I.D. x 2" O.D.)	1
6	Installation Adapter (1.122" L x 0.941" I.D. x 3" O.D.)	1

Part	Description	Qty
7	Removal Adapter (1.148" L x 1/2" I.D. x 3" O.D.)	1
8	Installing Cup (3.676" L x 1-3/4" I.D. x 2" O.D.)	1
9	Receiving Cup (2-1/2" L x 2" I.D. x 2-1/4" O.D.)	1
10	Install Cup Adapter (0.845" L x 1.879" I.D. x 2-1/4" O.D.)	1
11	Carrying Case	1



**Record Product's Serial Number Here:** \_\_\_\_\_

**Note:** If product has no serial number, record month and year of purchase instead.

**Note:** Some parts are listed and shown for illustration purposes only, and are not available individually as replacement parts.

***PITTSBURGH***<sup>®</sup> **AUTOMOTIVE**

3491 Mission Oaks Blvd., • P. O. Box 6009 • Camarillo, CA 93011 • (800) 444-3353