

# Owner's Manual & Safety Instructions

**Save This Manual** Keep this manual for the safety warnings and precautions, assembly, operating, inspection, maintenance and cleaning procedures. Write the product's serial number in the back of the manual near the assembly diagram (or month and year of purchase if product has no number). Keep this manual and the receipt in a safe and dry place for future reference.

**CHICAGO**  **ELECTRIC**  
POWER TOOLS

**ITEM 61778**

## **ELECTRIC DRILL BIT SHARPENER**



Visit our website at: <http://www.harborfreight.com>  
Email our technical support at: [productsupport@harborfreight.com](mailto:productsupport@harborfreight.com)

When unpacking, make sure that the product is intact and undamaged. If any parts are missing or broken, please call 1-888-866-5797 as soon as possible.

Copyright© 2013 by Harbor Freight Tools®. All rights reserved.  
No portion of this manual or any artwork contained herein may be reproduced in any shape or form without the express written consent of Harbor Freight Tools. Diagrams within this manual may not be drawn proportionally. Due to continuing improvements, actual product may differ slightly from the product described herein.  
Tools required for assembly and service may not be included.

### **⚠ WARNING**

**Read this material before using this product.  
Failure to do so can result in serious injury.  
SAVE THIS MANUAL.**

# Table of Contents





Safety .....	2	Maintenance .....	8
Specifications .....	5	Parts List and Diagram .....	10
Setup .....	5	Warranty .....	12
Operation.....	6		

SAFETY

# CHICAGO ELECTRIC<sup>®</sup> POWER TOOLS

SETUP

## WARNING SYMBOLS AND DEFINITIONS

	This is the safety alert symbol. It is used to alert you to potential personal injury hazards. Obey all safety messages that follow this symbol to avoid possible injury or death.
	Indicates a hazardous situation which, if not avoided, will result in death or serious injury.
	Indicates a hazardous situation which, if not avoided, could result in death or serious injury.
	Indicates a hazardous situation which, if not avoided, could result in minor or moderate injury.
	Addresses practices not related to personal injury.

OPERATION

## IMPORTANT SAFETY INFORMATION

### General Tool Safety Warnings

#### WARNING

**Read all safety warnings and instructions.**

*Failure to follow the warnings and instructions may result in electric shock, fire and/or serious injury.*

**Save all warnings and instructions for future reference.**

1. KEEP GUARDS IN PLACE and in working order.
2. REMOVE ADJUSTING KEYS AND WRENCHES. Form habit of checking to see that keys and adjusting wrenches are removed from tool before turning it on.
3. KEEP WORK AREA CLEAN. Cluttered areas and benches invite accidents.
4. DON'T USE IN DANGEROUS ENVIRONMENT. Don't use power tools in damp or wet locations, or expose them to rain. Keep work area well lighted.
5. KEEP CHILDREN AWAY. All visitors should be kept safe distance from work area.
6. MAKE WORKSHOP KID PROOF with padlocks, master switches, or by removing starter keys.
7. DON'T FORCE TOOL. It will do the job better and safer at the rate for which it was designed.
8. USE RIGHT TOOL. Don't force tool or attachment to do a job for which it was not designed.

MAINTENANCE

**Table A: RECOMMENDED MINIMUM WIRE GAUGE FOR EXTENSION CORDS (120 VOLT)**

NAMEPLATE AMPERES (at full load)	EXTENSION CORD LENGTH			
	25'	50'	100'	150'
0 – 6	18	16	16	14
6.1 – 10	18	16	14	12
10.1 – 12	16	16	14	12
12.1 – 16	14	12	<b>Do not use.</b>	

9. **USE PROPER EXTENSION CORD.** Make sure your extension cord is in good condition. When using an extension cord, be sure to use one heavy enough to carry the current your product will draw. An undersized cord will cause a drop in line voltage resulting in loss of power and overheating. Table A shows the correct size to use depending on cord length and nameplate ampere rating. If in doubt, use the next heavier gauge. The smaller the gauge number, the heavier the cord.
10. **WEAR PROPER APPAREL.** Do not wear loose clothing, neckties, rings, bracelets, or other jewelry which may get caught in moving parts. Nonslip footwear is recommended. Wear protective hair covering to contain long hair.
11. **ALWAYS USE SAFETY GLASSES.** Also use face or dust mask if cutting operation is dusty. Everyday eyeglasses only have impact resistant lenses, they are NOT safety glasses.
12. **DON'T OVERREACH.** Keep proper footing and balance at all times.
13. **MAINTAIN TOOLS WITH CARE.** Keep tools sharp and clean for best and safest performance. Follow instructions for lubricating and changing accessories.
14. **DISCONNECT TOOLS** before servicing; when changing accessories, such as blades, bits, cutters, and the like.
15. **REDUCE THE RISK OF UNINTENTIONAL STARTING.** Make sure switch is in off position before plugging in.
16. **USE RECOMMENDED ACCESSORIES.** Consult the owner's manual for recommended accessories. The use of improper accessories may cause risk of injury to persons.
17. **CHECK DAMAGED PARTS.** Before further use of the tool, a guard or other part that is damaged should be carefully checked to determine that it will operate properly and perform its intended function – check for alignment of moving parts, binding of moving parts, breakage of parts, mounting, and any other conditions that may affect its operation. A guard or other part that is damaged should be properly repaired or replaced.
18. **NEVER LEAVE TOOL RUNNING UNATTENDED. TURN POWER OFF.**

## Grounding Instructions



### ⚠ WARNING

TO PREVENT ELECTRIC SHOCK AND DEATH FROM INCORRECT GROUNDING WIRE CONNECTION READ AND FOLLOW THESE INSTRUCTIONS:

## 110-120 VAC Double Insulated Tools: Tools with Two Prong Plugs

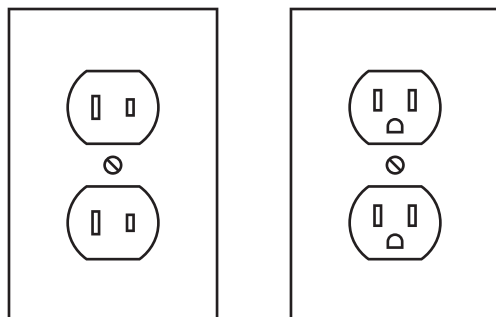

Outlets for 2-Prong Plug

1. To reduce the risk of electric shock, double insulated equipment has a polarized plug (one blade is wider than the other). This plug will fit in a polarized outlet only one way. If the plug does not fit fully in the outlet, reverse the plug. If it still does not fit, contact a qualified electrician to install the proper outlet. Do not change the plug in any way.
2. Double insulated tools may be used in either of the 120 volt outlets shown in the preceding illustration. **(See Outlets for 2-Prong Plug.)**

# Grinder Safety Warnings

## For Your Own Safety Read Instruction Manual Before Operating Grinder

1. Wear eye protection.
2. Use grinding wheel suitable for speed of grinder.
3. Replace cracked wheel immediately.
4. Always use guards. Only plug in sharpener when fully assembled.
5. Be careful of bits when sharpening. Bits will become hot. Handle with care; allow tips to cool before storing.
6. Housing may become hot while using. This is a normal result of operation.
7. Maintain labels and nameplates on the tool. These carry important safety information. If unreadable or missing, contact Harbor Freight Tools for a replacement.
8. **DO NOT OPERATE WITH ANY GUARD DISABLED, DAMAGED, OR REMOVED.**
9. The use of accessories or attachments not recommended by the manufacturer may result in a risk of injury to persons.
10. When servicing use only identical replacement parts.
11. Only use safety equipment that has been approved by an appropriate standards agency. Unapproved safety equipment may not provide adequate protection. Eye protection must be ANSI-approved and breathing protection must be NIOSH-approved for the specific hazards in the work area.
12. Stay alert, watch what you are doing and use common sense when operating a power tool. Do not use a power tool while you are tired or under the influence of drugs, alcohol or medication. A moment of inattention while operating power tools may result in serious personal injury.
13. Industrial applications must follow OSHA guidelines.
14. Avoid unintentional starting. Prepare to begin work before turning on the tool.
15. People with pacemakers should consult their physician(s) before use. Electromagnetic fields in close proximity to heart pacemaker could cause pacemaker interference or pacemaker failure.
16. **WARNING:** Some dust created by power sanding, sawing, grinding, drilling, and other construction activities, contains chemicals known [to the State of California] to cause cancer, birth defects or other reproductive harm. Some examples of these chemicals are:
  - Lead from lead-based paints
  - Crystalline silica from bricks and cement or other masonry products
  - Arsenic and chromium from chemically treated lumberYour risk from these exposures varies, depending on how often you do this type of work. To reduce your exposure to these chemicals: work in a well ventilated area, and work with approved safety equipment, such as those dust masks that are specially designed to filter out microscopic particles. (California Health & Safety Code § 25249.5, *et seq.*)
17. **WARNING:** Handling the cord on this product will expose you to lead, a chemical known to the State of California to cause cancer, and birth defects or other reproductive harm. Wash hands after handling. (California Health & Safety Code § 25249.5, *et seq.*)
18. The warnings, precautions, and instructions discussed in this instruction manual cannot cover all possible conditions and situations that may occur. It must be understood by the operator that common sense and caution are factors which cannot be built into this product, but must be supplied by the operator.

## Vibration Safety

This tool vibrates during use. Repeated or long-term exposure to vibration may cause temporary or permanent physical injury, particularly to the hands, arms and shoulders. To reduce the risk of vibration-related injury:

1. Anyone using vibrating tools regularly or for an extended period should first be examined by a doctor and then have regular medical check-ups to ensure medical problems are not being caused or worsened from use. Pregnant women or people who have impaired blood circulation to the hand, past hand injuries, nervous system disorders, diabetes, or Raynaud's Disease should not use this tool. If you feel any medical or physical symptoms related to vibration (such as tingling, numbness, and white or blue fingers), seek medical advice as soon as possible.
2. Do not smoke during use. Nicotine reduces the blood supply to the hands and fingers, increasing the risk of vibration-related injury.
3. Use tools with the lowest vibration when there is a choice between different processes.
4. Include vibration-free periods each day of work.

5. Grip workpiece as lightly as possible (while still keeping safe control of it). Let the tool do the work.

6. To reduce vibration, maintain the tool as explained in this manual. If any abnormal vibration occurs, stop use immediately.



## SAVE THESE INSTRUCTIONS.

### Specifications

Electrical Rating	120VAC / 60Hz / 0.35A
Motor No Load Speed	1700 RPM
Working Capacity	9/64" to 25/64" (3mm - 10mm)

### Setup - Before Use:



Read the **ENTIRE IMPORTANT SAFETY INFORMATION** section at the beginning of this manual including all text under subheadings therein before set up or use of this product.

**Note:** For additional information regarding the parts listed in the following pages, refer to the Assembly Diagram near the end of this manual.

### Adjusting the Grinding Wheel

1. Turn the Adjustment Knob to the right to raise the wheel. This will give you an aggressive cutting action. This is also useful when you are working with short bits.
2. Lower the wheel by turning the Knob to the left. This is desirable when you wish a finer ground edge, though it will take longer and require more repetitions.

### Functions

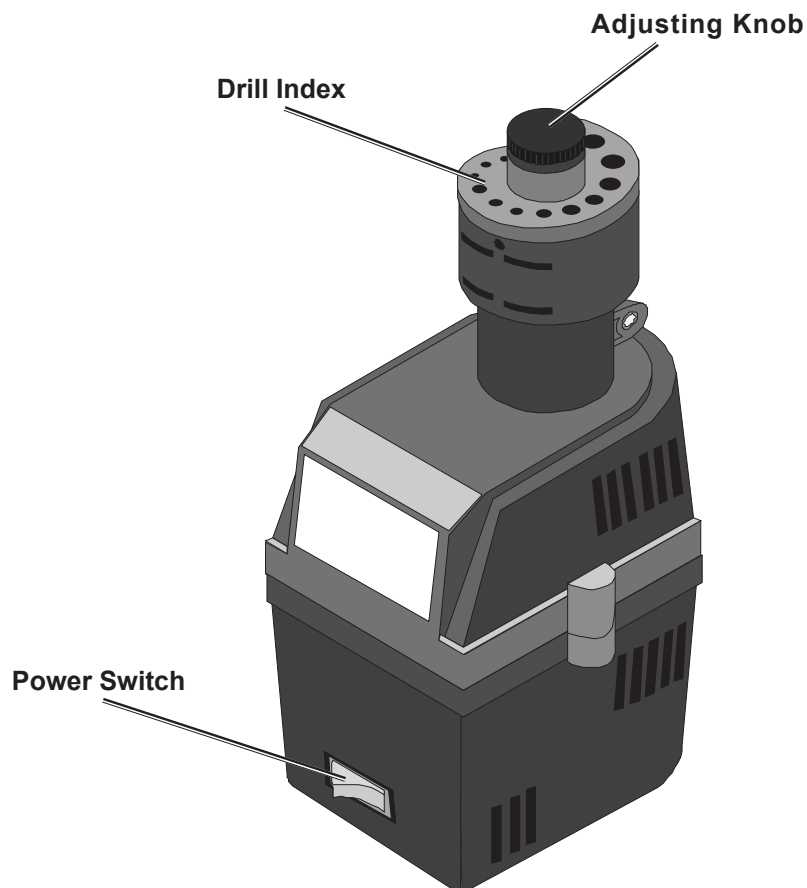

## Operating Instructions



Read the **ENTIRE IMPORTANT SAFETY INFORMATION** section at the beginning of this manual including all text under subheadings therein before set up or use of this product.

### **WARNING**

**TO PREVENT SERIOUS INJURY:**

**DO NOT OPERATE WITH ANY GUARD DISABLED, DAMAGED, OR REMOVED.**

## Workpiece and Work Area Set Up

1. Designate a work area that is clean and well-lit. The work area must not allow access by children or pets to prevent distraction and injury.
2. Route the power cord along a safe route to reach the work area without creating a tripping hazard or exposing the power cord to possible damage. The power cord must reach the work area with enough extra length to allow free movement while working.
3. There must not be objects, such as utility lines, nearby that will present a hazard while working.
4. Clean bits to be sharpened thoroughly.
5. Place sharpener on a flat, sturdy surface.

## General Operating Instructions

1. Make sure that the Switch is in the off-position, then plug in the tool.
2. Select a clean bit to be sharpened and match its size with one of the holes in the head.
3. Put the bit into the appropriate hole and twist until it locks into place. See Figure A.
4. Lean the bit towards the number on the outside of the hole. See Figure B.
5. Turn the unit on while exerting a slight downward pressure onto the bit.
6. Turn unit off after about 5-10 seconds.
7. Examine bit according to the "Sharpening Troubleshooting" section, below.
8. **Sharpening Tips:**
  - a. If the tip of the bit is turning blue, it is overheating. Reduce the amount of pressure and sharpening time. Cool bit in water and allow it to dry between sharpening.
  - b. If one edge is longer than the other, and the point is not centered, sharpen the shorter side for a little less time. To prevent this from happening, sharpen both sides the same amount of time, using the same amount of pressure.
  - c. If sharpening a broken (rather than a dull bit) and the time required to get a sufficient edge is too long, rough the bit into shape first using a bench grinder.
9. **CAUTION!** Do not touch the end of the bit after it is sharpened. The bit will become hot!
10. Repeat the above steps to the other side of the bit. Sharpen both sides the same amount of time, using the same amount of pressure.
11. Repeat the above steps as necessary to sharpen bit.
12. To prevent accidents, turn off the tool and unplug the tool from its electrical outlet after use. Clean, then store the tool indoors out of children's reach.

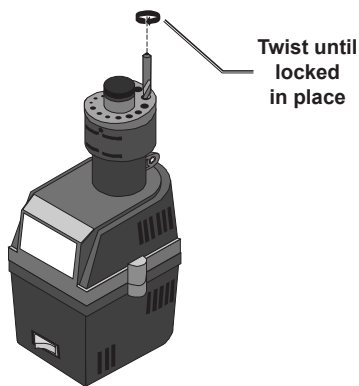

**Figure A: Putting Bits into the Sharpener**

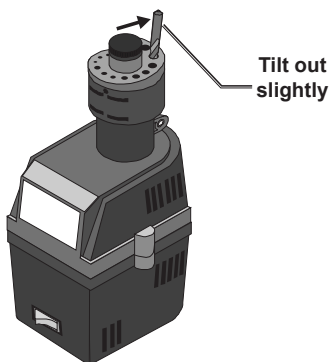

**Figure B: Tilt the Bit**

## Properly Sharpened Bits

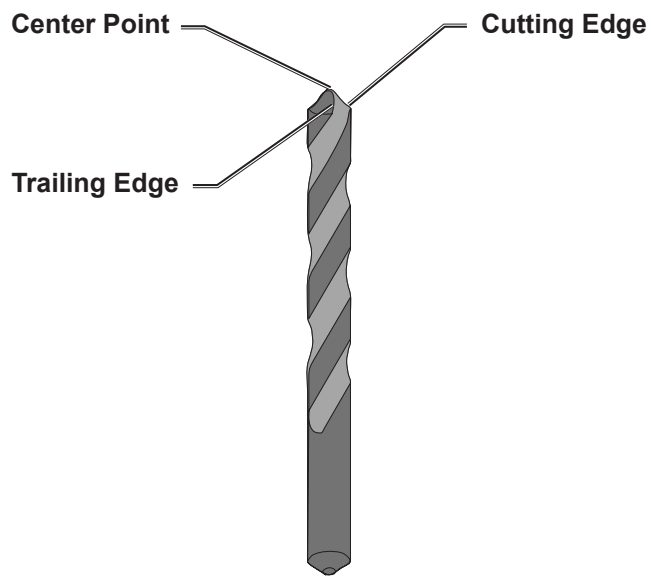

Figure C: Parts of the Bit

Bit is properly sharpened when it has the following characteristics.

1. A sharp point in the center of the bit.
2. Two sharp and equal cutting edges.
3. Two trailing edges that are slightly lower than the cutting edges.

## Maintenance and Servicing



Procedures not specifically explained in this manual must be performed only by a qualified technician.

### **WARNING**

**TO PREVENT SERIOUS INJURY FROM ACCIDENTAL OPERATION:**

Turn the Power Switch of the tool off and unplug the tool from its electrical outlet before performing any procedure in this section.

**TO PREVENT SERIOUS INJURY FROM TOOL FAILURE:**

Do not use damaged equipment. If abnormal noise or vibration occurs, have the problem corrected before further use.

## Cleaning, Maintenance, and Lubrication

- BEFORE EACH USE**, inspect the general condition of the tool. Check for:
  - loose hardware,
  - misalignment or binding of moving parts,
  - cracked or broken parts,
  - damaged electrical wiring, and
  - any other condition that may affect its safe operation.
- AFTER USE**, wipe external surfaces of the tool with clean cloth.
- Periodically, wear ANSI-approved safety goggles and NIOSH-approved breathing protection and blow dust and grit out of the motor vents using dry compressed air.
- WARNING!** If the supply cord of this power tool is damaged, it must be replaced only by a qualified service technician.

## Wheel Storage and Handling

- Handle wheels carefully to prevent dropping or bumping. Do not use wheels that have been dropped or bumped.
- Store wheels in shelves, racks, boxes, or drawers. Keep storage area dry and above freezing. Any grinding or cut-off wheels exposed to humidity or freezing temperatures must not be used.

## Changing the Wheel

- Change the Grinding Wheel (7) if grooves or ridges mar the evenness of the grinding surface.
- Remove the two Screws (12). See Figure D.
- Remove the Index Head Assembly (1, 2, & 8).
- Remove the Wheel Assembly. Make sure the Spring (5) stays in place. Refer to the Parts Diagram.
- Unscrew the Adjustment Cylinder (4) from the Wheel Base (8) by turning clockwise.
- Pry out the Washer (6).
- Pop out the Wheel Base (8).
- Press new Wheel (7) onto Wheel Base (8), replace Washer (6), and screw the Cylinder (4) back in.
- Replace Wheel Assembly onto unit. Make sure that the inner flats of the Adjustment Cylinder (4) match the outer flats of the Drive Spindle (11).
- Replace the Drill Index and Screws (12).

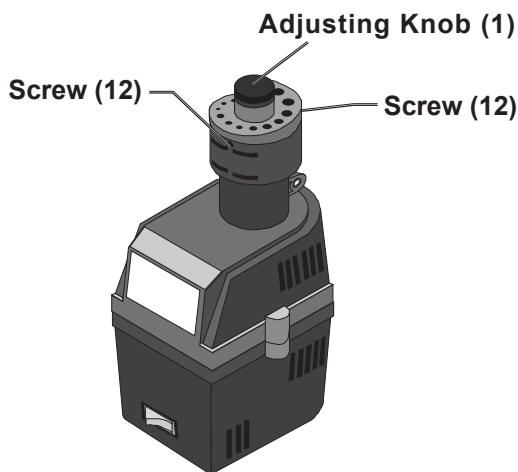

Figure D: Removing the Screws



# Troubleshooting

Problem	Possible Causes	Likely Solutions
Tool will not start.	<ol style="list-style-type: none"> <li>1. Cord not connected.</li> <li>2. No power at outlet.</li> <li>3. Tool's thermal reset breaker tripped (if equipped).</li> <li>4. Internal damage or wear. (Carbon brushes or switch, for example.)</li> </ol>	<ol style="list-style-type: none"> <li>1. Check that cord is plugged in.</li> <li>2. Check power at outlet. If outlet is unpowered, turn off tool and check circuit breaker. If breaker is tripped, make sure circuit is right capacity for tool and circuit has no other loads.</li> <li>3. Turn off tool and allow to cool. Press reset button on tool.</li> <li>4. Have technician service tool.</li> </ol>
Tool operates slowly.	Extension cord too long or wire size too small.	Eliminate use of extension cord. If an extension cord is needed, use one with the proper diameter for its length and load. See <b>Table A</b> on page 3.
Performance decreases over time.	<ol style="list-style-type: none"> <li>1. Accessory dull or damaged.</li> <li>2. Carbon brushes worn or damaged.</li> </ol>	<ol style="list-style-type: none"> <li>1. Keep cutting accessories sharp. Replace as needed.</li> <li>2. Have qualified technician replace brushes.</li> </ol>
Excessive noise or rattling.	Internal damage or wear. (Carbon brushes or bearings, for example.)	Have technician service tool.
Overheating.	<ol style="list-style-type: none"> <li>1. Forcing machine to work too fast.</li> <li>2. Accessory dull or damaged.</li> <li>3. Blocked motor housing vents.</li> <li>4. Motor being strained by long or small diameter extension cord.</li> </ol>	<ol style="list-style-type: none"> <li>1. Allow machine to work at its own rate.</li> <li>2. Keep cutting accessories sharp. Replace as needed.</li> <li>3. Wear ANSI-approved safety goggles and NIOSH-approved dust mask/respirator while blowing dust out of motor using compressed air.</li> <li>4. Eliminate use of extension cord. If an extension cord is needed, use one with the proper diameter for its length and load. See <b>Table A</b> on page 3.</li> </ol>
Motor turns on, but wheel does not spin	Adjustment Cylinder's inner flats are not even with the outer flats of the Drive Spindle	Even out the Adjustment Cylinder's (4) inner flats with the outer flats of the Drive Spindle (11) as described in "Changing the Wheel".



**Follow all safety precautions whenever diagnosing or servicing the tool.  
Disconnect power supply before service.**

**PLEASE READ THE FOLLOWING CAREFULLY**

THE MANUFACTURER AND/OR DISTRIBUTOR HAS PROVIDED THE PARTS LIST AND ASSEMBLY DIAGRAM IN THIS MANUAL AS A REFERENCE TOOL ONLY. NEITHER THE MANUFACTURER OR DISTRIBUTOR MAKES ANY REPRESENTATION OR WARRANTY OF ANY KIND TO THE BUYER THAT HE OR SHE IS QUALIFIED TO MAKE ANY REPAIRS TO THE PRODUCT, OR THAT HE OR SHE IS QUALIFIED TO REPLACE ANY PARTS OF THE PRODUCT. IN FACT, THE MANUFACTURER AND/OR DISTRIBUTOR EXPRESSLY STATES THAT ALL REPAIRS AND PARTS REPLACEMENTS SHOULD BE UNDERTAKEN BY CERTIFIED AND LICENSED TECHNICIANS, AND NOT BY THE BUYER. THE BUYER ASSUMES ALL RISK AND LIABILITY ARISING OUT OF HIS OR HER REPAIRS TO THE ORIGINAL PRODUCT OR REPLACEMENT PARTS THERETO, OR ARISING OUT OF HIS OR HER INSTALLATION OF REPLACEMENT PARTS THERETO.

**Parts List**

Part	Description	Qty
1	Adjustment Knob	2
2	Index	1
3	Cap Ring	1
4	Adjustment Cylinder	2
5	Spring	2
6	Washer	2
7	Grinding Wheel	1
8	Wheel Base	2
9	Cover	2
10	Bearing 6202	2
11	Drive Spindle	2
12	Screw 4*8	4
13	Housing	1
14	Screw M5*35	1
15	Spring Washer	2
16	Nut M5	1
17	Upper Motor Housing	1

Part	Description	Qty
18	Connector-Male	1
19	Motor	1
20	Cover	2
21	Screw 4*16	1
22	Capacitor	1
23	Screw 4*16	2
24	Pressure Plate	1
25	Cord Protector	1
26	Terminal	2
27	Cord	1
28	Screw 4*16	3
29	Rubber Pad	4
30	Washer	4
31	Screw 4*12	4
32	Switch	1
33	Motor housing	1

**Record Product's Serial Number Here:** \_\_\_\_\_

**Note:** If product has no serial number, record month and year of purchase instead.

**Note:** Some parts are listed and shown for illustration purposes only, and are not available individually as replacement parts.

# Assembly Diagram

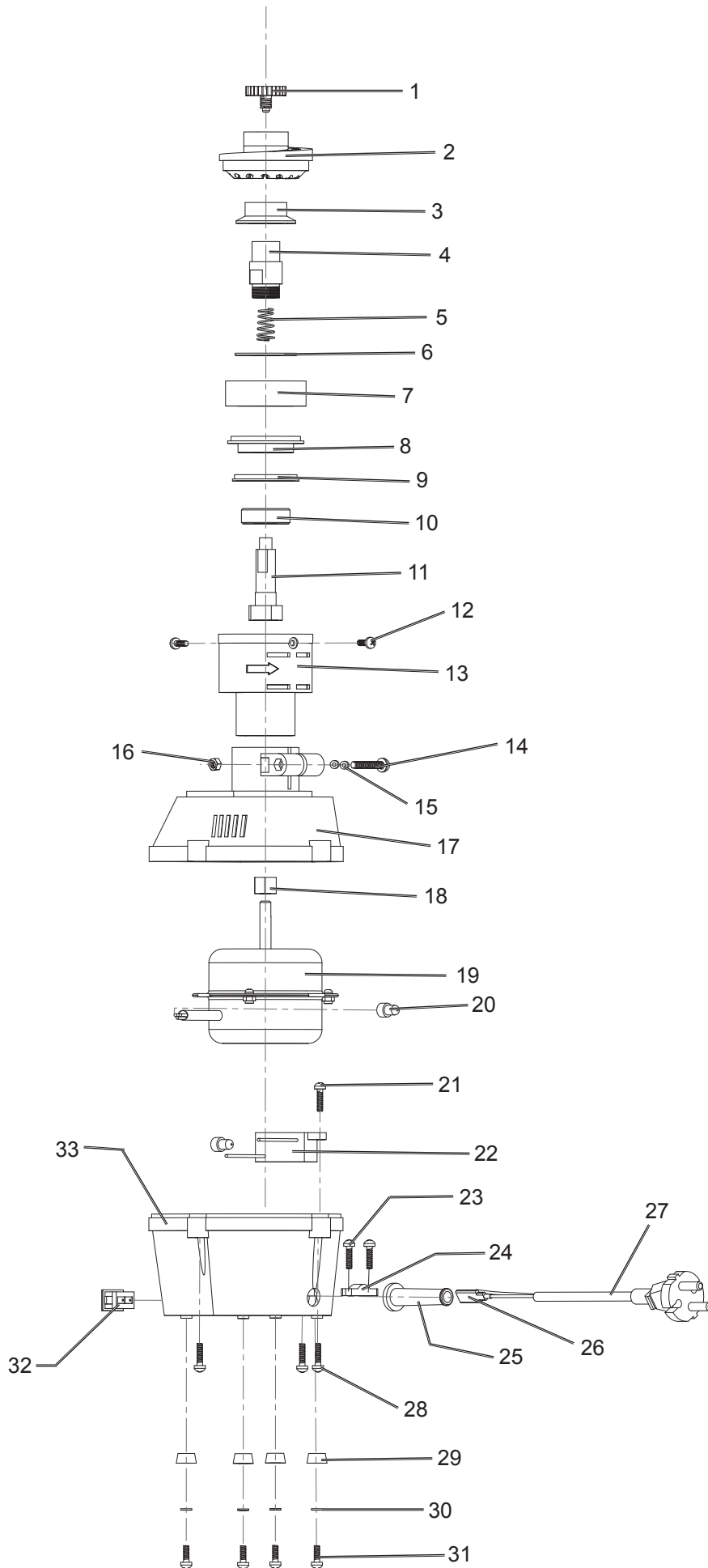

SAFETY

SETUP

OPERATION

MAINTENANCE

## Limited 90 Day Warranty

Harbor Freight Tools Co. makes every effort to assure that its products meet high quality and durability standards, and warrants to the original purchaser that this product is free from defects in materials and workmanship for the period of 90 days from the date of purchase. This warranty does not apply to damage due directly or indirectly, to misuse, abuse, negligence or accidents, repairs or alterations outside our facilities, criminal activity, improper installation, normal wear and tear, or to lack of maintenance. We shall in no event be liable for death, injuries to persons or property, or for incidental, contingent, special or consequential damages arising from the use of our product. Some states do not allow the exclusion or limitation of incidental or consequential damages, so the above limitation of exclusion may not apply to you. THIS WARRANTY IS EXPRESSLY IN LIEU OF ALL OTHER WARRANTIES, EXPRESS OR IMPLIED, INCLUDING THE WARRANTIES OF MERCHANTABILITY AND FITNESS.

To take advantage of this warranty, the product or part must be returned to us with transportation charges prepaid. Proof of purchase date and an explanation of the complaint must accompany the merchandise. If our inspection verifies the defect, we will either repair or replace the product at our election or we may elect to refund the purchase price if we cannot readily and quickly provide you with a replacement. We will return repaired products at our expense, but if we determine there is no defect, or that the defect resulted from causes not within the scope of our warranty, then you must bear the cost of returning the product.

This warranty gives you specific legal rights and you may also have other rights which vary from state to state.

**CHICAGO  ELECTRIC®**  
**POWER TOOLS**

3491 Mission Oaks Blvd. • PO Box 6009 • Camarillo, CA 93011 • 1-888-866-5797