

Owner's Manual & Safety Instructions

Save This Manual Keep this manual for the safety warnings and precautions, assembly, operating, inspection, maintenance and cleaning procedures. Write the product's serial number in the back of the manual near the assembly diagram (or month and year of purchase if product has no number). Keep this manual and the receipt in a safe and dry place for future reference.

**CHICAGO  ELECTRIC
POWER TOOLS**

ITEM 62133

800 WATT HEAT BOND **CARPET SEAMING IRON**



Visit our website at: <http://www.harborfreight.com>
Email our technical support at: productsupport@harborfreight.com

REV 14f

When unpacking, make sure that the product is intact and undamaged. If any parts are missing or broken, please call 1-888-866-5797 as soon as possible.

⚠ WARNING

**Read this material before using this product.
Failure to do so can result in serious injury.
SAVE THIS MANUAL.**

Copyright© 2014 by Harbor Freight Tools®. All rights reserved.
No portion of this manual or any artwork contained herein may be reproduced in any shape or form without the express written consent of Harbor Freight Tools. Diagrams within this manual may not be drawn proportionally. Due to continuing improvements, actual product may differ slightly from the product described herein. Tools required for assembly and service may not be included.

SAVE THIS MANUAL

Keep this manual for the safety warnings and precautions, assembly, operating, inspection, maintenance and cleaning procedures. Write the product's serial number in the back of the manual near the assembly diagram (or month and year of purchase if product has no number). Keep this manual and the receipt in a safe and dry place for future reference.

IMPORTANT SAFETY INFORMATION

In this manual, on the labeling, and all other information provided with this product:



This is the safety alert symbol. It is used to alert you to potential personal injury hazards. Obey all safety messages that follow this symbol to avoid possible injury or death.

DANGER

DANGER indicates a hazardous situation which, if not avoided, will result in death or serious injury.

WARNING

WARNING indicates a hazardous situation which, if not avoided, could result in death or serious injury.

CAUTION

CAUTION, used with the safety alert symbol, indicates a hazardous situation which, if not avoided, could result in minor or moderate injury.

NOTICE

NOTICE is used to address practices not related to personal injury.

CAUTION

CAUTION, without the safety alert symbol, is used to address practices not related to personal injury.

General Tool Safety Warnings



WARNING Read all safety warnings and instructions.

Failure to follow the warnings and instructions may result in electric shock, fire and/or serious injury.

Save all warnings and instructions for future reference.

1. **Work area safety**
 - a. **Keep work area clean and well lit.** *Cluttered or dark areas invite accidents.*
 - b. **Do not operate tools in explosive atmospheres, such as in the presence of flammable liquids, gases or dust.** *Tools create sparks which may ignite the dust or fumes.*
 - c. **Keep children and bystanders away while operating a tool.** *Distractions can cause you to lose control.*
2. **Electrical safety**
 - a. **Tool plugs must match the outlet. Never modify the plug in any way. Do not use any adapter plugs with**

grounded tools. *Unmodified plugs and matching outlets will reduce risk of electric shock.*

b. Avoid body contact with grounded surfaces such as pipes, radiators, ranges and refrigerators. *There is an increased risk of electric shock if your body is grounded.*

c. Do not expose tools to rain or wet conditions. *Water entering a tool will increase the risk of electric shock.*

d. Do not abuse the cord. Never use the cord for carrying, pulling or unplugging the tool. Keep cord away from heat, oil, sharp edges or moving parts. *Damaged or entangled cords increase the risk of electric shock.*

e. If operating a tool in a damp location is unavoidable, use a Ground Fault Circuit Interrupter (GFCI) protected supply. *Use of a GFCI reduces the risk of electric shock.*

3. Personal safety

a. Stay alert, watch what you are doing and use common sense when operating a tool. Do not use a tool while you are tired or under the influence of drugs, alcohol or medication. *A moment of inattention while operating tools may result in serious personal injury.*

b. Use personal protective equipment. Always wear eye protection. *Safety equipment such as fresh air mask, non-skid safety shoes, hard hat, or hearing protection used for appropriate conditions will reduce personal injuries.*

c. Do not overreach. Keep proper footing and balance at all times.

This enables better control of the tool in unexpected situations.

d. Only use safety equipment that has been approved by an appropriate standards agency. *Unapproved safety equipment may not provide adequate protection. Eye protection must be ANSI-approved and breathing protection must be NIOSH-approved for the specific hazards in the work area.*

4. Tool use and care

a. Do not force the tool. Use the correct tool for your application. *The correct tool will do the job better and safer at the rate for which it was designed.*

b. Disconnect the plug from the power source and allow to cool before making any adjustments, changing accessories, or storing this tool. *Such preventive safety measures reduce the risk of damage or injury.*

c. Store idle tools out of the reach of children and do not allow persons unfamiliar with this tool or these instructions to operate the tool. *Tools are dangerous in the hands of untrained users.*

d. Maintain tools. Check for misalignment or breakage of parts and any other condition that may affect the tool's operation. If damaged, have the tool repaired before use. *Many accidents are caused by poorly maintained tools.*

5. Service

a. Have your tool serviced by a qualified repair person using only identical replacement parts. *This*

will ensure that the safety of the tool is maintained.

Safety Warnings

1. Maintain labels and nameplates on the tool. These carry important safety information. If unreadable or missing, contact Harbor Freight Tools for a replacement.
2. Place securely on Iron Holder (6) when not in use.
3. Keep away from flammable objects.
4. Do not overheat adhesive.
5. When using a handheld tool, maintain a firm, controlling grip on the tool.
6. Do not leave the tool unattended when it is plugged into an electrical outlet. Unplug the tool from its electrical outlet and allow to cool down before leaving.
7. This product is not a toy. Keep it out of reach of children.
8. Any power cord must be properly grounded. Ground Fault Circuit Interrupter (GFCI) should also be implemented – it prevents sustained electrical shock.
9. **WARNING:** The cord of this product contains lead, a chemical known to the State of California to cause cancer, and birth defects or other reproductive harm. Wash hands after handling. (California Health & Safety Code § 25249.5, *et seq.*)
10. The warnings, precautions, and instructions discussed in this instruction manual cannot cover all possible conditions and situations that may occur. It must

be understood by the operator that common sense and caution are factors which cannot be built into this product, but must be supplied by the operator.



SAVE THESE INSTRUCTIONS.

GROUNDING

⚠ WARNING

TO PREVENT ELECTRIC SHOCK



AND DEATH FROM INCORRECT GROUNDING WIRE CONNECTION:
Check with a qualified electrician if you are in doubt as to whether the outlet is properly grounded. Do not modify the power cord plug provided with the tool. Never remove the grounding prong from the plug. Do not use the tool if the power cord or plug is damaged. If damaged, have it repaired by a qualified service technician before use. If the plug will not fit the outlet, have a proper outlet installed by a qualified electrician.

Grounded Tools: Tools with Three Prong Plugs

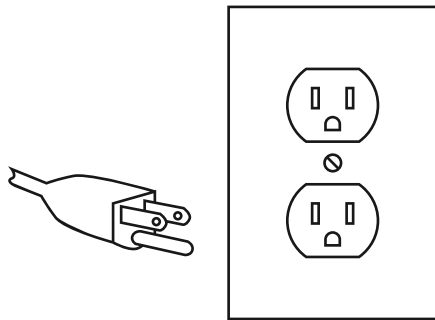

3-Prong Plug and Outlet

1. Tools marked with “Grounding Required” have a three wire cord and three prong grounding plug. The plug must be connected to a properly grounded outlet. If the tool should electrically malfunction or break down, grounding provides a low resistance path to carry electricity away from the user, reducing the risk of electric shock. **(See 3-Prong Plug and Outlet.)**
2. The grounding prong in the plug is connected through the green wire inside the cord to the grounding system in the tool. The green wire in the cord must be the only wire connected to the tool’s grounding system and must never be attached to an electrically “live” terminal. **(See 3-Prong Plug and Outlet.)**
3. The tool must be plugged into an appropriate outlet, properly installed and grounded in accordance with all codes and ordinances. The plug and outlet should look like those in the preceding illustration. **(See 3-Prong Plug and Outlet.)**

Extension Cords



1. **Grounded** tools require a three wire extension cord. **Double Insulated** tools can use either a two or three wire extension cord.
2. As the distance from the supply outlet increases, you must use a heavier gauge extension cord. Using extension cords with inadequately sized wire causes a serious drop in voltage, resulting in loss of power and possible tool damage. **(See Table A.)**
3. The smaller the gauge number of the wire, the greater the capacity of the cord. For example, a 14 gauge cord can carry a higher current than a 16 gauge cord. **(See Table A.)**
4. When using more than one extension cord to make up the total length, make sure each cord contains at least the minimum wire size required. **(See Table A.)**
5. If you are using one extension cord for more than one tool, add the nameplate amperes and use the sum to determine the required minimum cord size. **(See Table A.)**
6. If you are using an extension cord outdoors, make sure it is marked with the suffix “W-A” (“W” in Canada) to indicate it is acceptable for outdoor use.
7. Make sure the extension cord is properly wired and in good electrical condition. Always replace a damaged extension cord or have it repaired by a qualified electrician before using it.
8. Protect the extension cords from sharp objects, excessive heat, and

damp or wet areas.

RECOMMENDED MINIMUM WIRE GAUGE FOR EXTENSION CORDS* (120/240 VOLT)					
NAMEPLATE AMPERES (at full load)	EXTENSION CORD LENGTH				
	25'	50'	75'	100'	150'
0 – 2.0	18	18	18	18	16
2.1 – 3.4	18	18	18	16	14
3.5 – 5.0	18	18	16	14	12
5.1 – 7.0	18	16	14	12	12
7.1 – 12.0	18	14	12	10	-
12.1 – 16.0	14	12	10	-	-
16.1 – 20.0	12	10	-	-	-

TABLE A * Based on limiting the line voltage drop to five volts at 150% of the rated amperes.

Symbology

	Double Insulated
	Canadian Standards Association
	Underwriters Laboratories, Inc.
VAC	Volts Alternating Current
A	Amperes
n ₀ xxxx/min.	No Load Revolutions per Minute (RPM)

SPECIFICATIONS

Electrical Requirements	120 VAC, 800 W
Power Cord	115" L, 3-Prong Grounded
Temperature Range	145° - 432° F

Temperature Setting

Heat Setting	Temperature Range F	Time to Reach
1	145° - 195°	2 Minutes
2	192° - 228°	3 Minutes
3	298° - 367°	3.5 Minutes
4	361° - 432°	4 Minutes

UNPACKING

When unpacking, make sure that the item is intact and undamaged. If any parts are missing or broken, please call Harbor Freight Tools at 1-888-866-5797 as soon as possible.

OPERATING INSTRUCTIONS



Read the **ENTIRE IMPORTANT SAFETY INFORMATION** section at the beginning of this manual including all text under subheadings therein before set up or use of this product.

Work Piece and Work Area Set Up

1. Designate a work area that is clean and well-lit. The work area must not allow access by children or pets to prevent injury and distraction.
2. Route the power cord along a safe route to reach the work area without creating a tripping hazard or exposing the power cord to possible damage. The power cord must reach the work area with enough extra length to allow free movement while working.
3. There must not be hazardous objects, such as utility lines or foreign objects, nearby that will present a hazard while working.

General Operating Instructions

1. Place the Iron Holder (6) on a flat, level, non-flammable surface.
2. Wear ANSI-approved safety goggles and heavy-duty work gloves during use. Forced-air ventilation may be required depending on the type of glue being heated.
3. Turn the Heat Control Knob (8) to the "OFF" position.
4. Place the Iron securely into the Iron Holder.
5. Turn the Heat Control Knob to the setting desired and wait until the Iron

reaches the desired temperature.
(See Temperature Setting chart.)
Consult the adhesive tape
manufacturer's instruction for proper
heat range.

6. Avoid touching the Heat Shield (9)
and Bottom Sole Plate (5) while
plugged in and hot.
7. Try the Iron on a scrap piece of
adhesive tape to test for desired
temperature result.
8. To prevent accidents, turn off the tool
and disconnect its power supply after
use. Allow to cool completely, then
clean and store the tool indoors out of
children's reach.

MAINTENANCE AND SERVICING



Procedures not specifically explained in this manual must be performed only by a qualified technician.

⚠️ WARNING

TO PREVENT SERIOUS INJURY

FROM ACCIDENTAL OPERATION:

Turn the Calibration Knob of the tool to its “OFF” position and unplug the tool from its electrical outlet before performing any inspection, maintenance, or cleaning procedures.

Cleaning and Maintenance

1. **BEFORE EACH USE**, inspect the general condition of the tool. Check for loose screws, misalignment or binding of moving parts, cracked or broken parts, damaged electrical wiring, and any other condition that may affect its safe operation.
2. **AFTER USE**, clean Bottom Sole Plate (5) of any glue or adhesive that may have transferred on by rubbing on a clean scrap of carpeting while still hot.
3. Place back on Iron Holder when not in use.
4. **⚠️ WARNING!** If the supply cord of this tool is damaged, it must be replaced only by a qualified service technician.

Troubleshooting

Problem	Possible Causes	Likely Solutions
Tool will not heat	<ol style="list-style-type: none"> 1. No power at outlet. 2. Cord not connected. 3. Heat Control Knob in OFF position. 	<ol style="list-style-type: none"> 1. Check power at outlet. 2. Check that cord is plugged in. 3. Turn Heat Control Knob to a heat setting position.



Follow all safety precautions whenever diagnosing or servicing the tool. Disconnect power supply before service.

PLEASE READ THE FOLLOWING CAREFULLY

THE MANUFACTURER AND/OR DISTRIBUTOR HAS PROVIDED THE PARTS LIST AND ASSEMBLY DIAGRAM IN THIS MANUAL AS A REFERENCE TOOL ONLY. NEITHER THE MANUFACTURER OR DISTRIBUTOR MAKES ANY REPRESENTATION OR WARRANTY OF ANY KIND TO THE BUYER THAT HE OR SHE IS QUALIFIED TO MAKE ANY REPAIRS TO THE PRODUCT, OR THAT HE OR SHE IS QUALIFIED TO REPLACE ANY PARTS OF THE PRODUCT. IN FACT, THE MANUFACTURER AND/OR DISTRIBUTOR EXPRESSLY STATES THAT ALL REPAIRS AND PARTS REPLACEMENTS SHOULD BE UNDERTAKEN BY CERTIFIED AND LICENSED TECHNICIANS, AND NOT BY THE BUYER. THE BUYER ASSUMES ALL RISK AND LIABILITY ARISING OUT OF HIS OR HER REPAIRS TO THE ORIGINAL PRODUCT OR REPLACEMENT PARTS THERETO, OR ARISING OUT OF HIS OR HER INSTALLATION OF REPLACEMENT PARTS THERETO.

PARTS LIST

Part	Description
1	Handle Set w(8) Screws
2	Cord Set (Relief Spring, Wire Connection Clip, two Screws
3	Thermostat w/ Extension Post for Control Knob
4	Top Sole Plate w/five Screws
5	Bottom Sole Plate, Aluminum, Flat
6	Iron Holder
7	Internal Wire Set (2 pieces)
8	Heat Control Knob
9	Heat Shield w/2 Screws and (1) Washer
10	Gasket (Top of heat shield for Handle Mount)
11	Gasket (Between Heat Shield for top of Sole Plate)
12	Heating Element

ASSEMBLY DIAGRAM

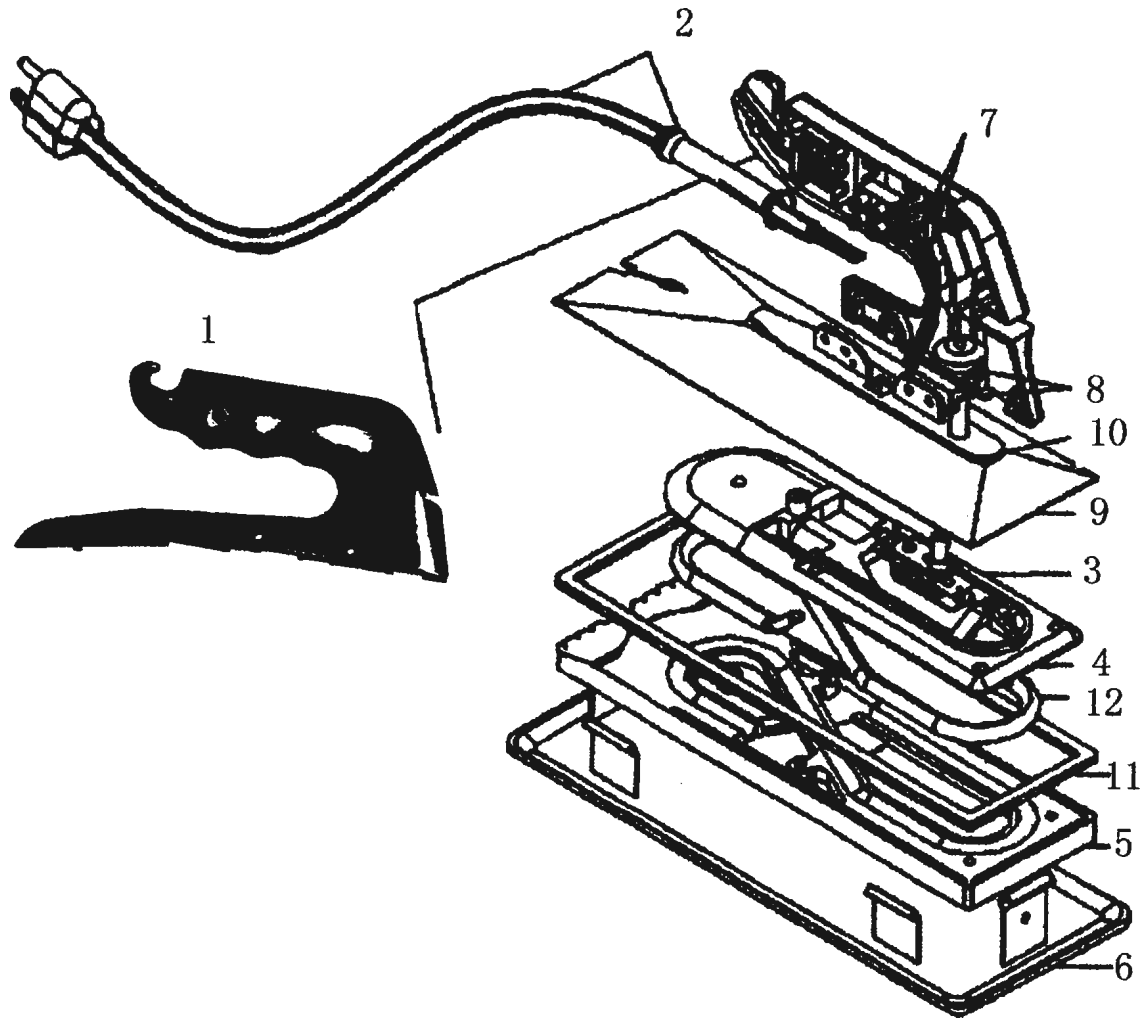

CIRCUIT DIAGRAM

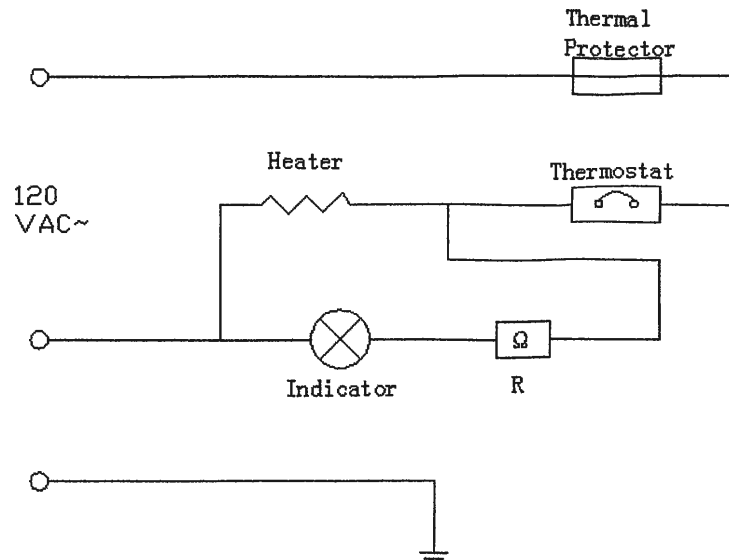

LIMITED 90 DAY WARRANTY

Harbor Freight Tools Co. makes every effort to assure that its products meet high quality and durability standards, and warrants to the original purchaser that this product is free from defects in materials and workmanship for the period of 90 days from the date of purchase. This warranty does not apply to damage due directly or indirectly, to misuse, abuse, negligence or accidents, repairs or alterations outside our facilities, criminal activity, improper installation, normal wear and tear, or to lack of maintenance. We shall in no event be liable for death, injuries to persons or property, or for incidental, contingent, special or consequential damages arising from the use of our product. Some states do not allow the exclusion or limitation of incidental or consequential damages, so the above limitation of exclusion may not apply to you. THIS WARRANTY IS EXPRESSLY IN LIEU OF ALL OTHER WARRANTIES, EXPRESS OR IMPLIED, INCLUDING THE WARRANTIES OF MERCHANTABILITY AND FITNESS.

To take advantage of this warranty, the product or part must be returned to us with transportation charges prepaid. Proof of purchase date and an explanation of the complaint must accompany the merchandise. If our inspection verifies the defect, we will either repair or replace the product at our election or we may elect to refund the purchase price if we cannot readily and quickly provide you with a replacement. We will return repaired products at our expense, but if we determine there is no defect, or that the defect resulted from causes not within the scope of our warranty, then you must bear the cost of returning the product.

This warranty gives you specific legal rights and you may also have other rights which vary from state to state.

3491 Mission Oaks Blvd. • PO Box 6009 • Camarillo, CA 93011 • 1-888-866-5797

Record Product's Serial Number Here: _____

Note: If product has no serial number, record month and year of purchase instead.

Note: Some parts are listed and shown for illustration purposes only, and are not available individually as replacement parts.