

Owner's Manual & Safety Instructions

Save This Manual Keep this manual for the safety warnings and precautions, assembly, operating, inspection, maintenance and cleaning procedures. Write the product's serial number in the back of the manual near the assembly diagram (or month and year of purchase if product has no number). Keep this manual and the receipt in a safe and dry place for future reference.

Mobile Bike Storage



Bicycles not included.

Visit our website at: <http://www.harborfreight.com>
Email our technical support at: tech@harborfreight.com

ITEM 61231

When unpacking, make sure that the product is intact and undamaged. If any parts are missing or broken, please call 1-800-444-3353 as soon as possible.

Copyright© 2013 by Harbor Freight Tools®. All rights reserved.
No portion of this manual or any artwork contained herein may be reproduced in any shape or form without the express written consent of Harbor Freight Tools. Diagrams within this manual may not be drawn proportionally. Due to continuing improvements, actual product may differ slightly from the product described herein.
Tools required for assembly and service may not be included.

⚠ WARNING

**Read this material before using this product.
Failure to do so can result in serious injury.
SAVE THIS MANUAL.**

Owner's Manual & Safety Instructions

Save This Manual Keep this manual for the safety warnings and precautions, assembly, operating, inspection, maintenance and cleaning procedures. Write the product's serial number in the back of the manual near the assembly diagram (or month and year of purchase if product has no number). Keep this manual and the receipt in a safe and dry place for future reference.

Mobile Bike Storage



Bicycles not included.

Visit our website at: <http://www.harborfreight.com>
Email our technical support at: tech@harborfreight.com

ITEM 61231

When unpacking, make sure that the product is intact and undamaged. If any parts are missing or broken, please call 1-800-444-3353 as soon as possible.

Copyright© 2013 by Harbor Freight Tools®. All rights reserved.
No portion of this manual or any artwork contained herein may be reproduced in any shape or form without the express written consent of Harbor Freight Tools. Diagrams within this manual may not be drawn proportionally. Due to continuing improvements, actual product may differ slightly from the product described herein.
Tools required for assembly and service may not be included.

⚠ WARNING

**Read this material before using this product.
Failure to do so can result in serious injury.
SAVE THIS MANUAL.**

Specifications

Maximum Weight Capacity	180 Lb. / 30 Lb. per bicycle
Maximum Bicycle Capacity	6
Dimensions	31"L x 31"W x 69"H

IMPORTANT SAFETY INFORMATION

Assembly Precautions

1. Assemble only according to these instructions. Improper assembly can create hazards.
2. Wear ANSI-approved safety goggles and heavy-duty work gloves during assembly.
3. Keep assembly area clean and well lit.
4. Keep bystanders out of the area during assembly.
5. Do not assemble when tired or when under the influence of alcohol, drugs or medication.
6. Weight capacity and other product capabilities apply to properly and completely assembled product only.

Use Precautions

1. **DO NOT STAND ON UNIT.**
2. Do not move with bicycles suspended. Remove bicycles before moving unit.
3. Do not exceed rated weight capacity.
Be aware of dynamic loading!
Sudden load movement may briefly create excess load causing product failure.
4. **Maintain Balance.** Be sure that weight is evenly distributed on the support bar at all times.
5. Do not use to store powered bicycles (electric/gasoline), scooters or motorcycles.
6. This product is not a toy. Do not allow children to play with or near this item.
7. Use as intended only.
8. Inspect before every use; do not use if parts are loose or damaged.
9. Do not store in damp or wet locations. Do not expose to rain.
10. Maintain product labels and nameplates. These carry important safety information. If unreadable or missing, contact Harbor Freight Tools for a replacement.
11. The warnings, precautions, and instructions discussed in this instruction manual cannot cover all possible conditions and situations that may occur. It must be understood by the operator that common sense and caution are factors which cannot be built into this product, but must be supplied by the operator.

Assembly Instructions



Read the **ENTIRE IMPORTANT SAFETY INFORMATION** section at the beginning of this document including all text under subheadings therein before set up or use of this product.

1. Attach Support Bar (1) to Upper Post (3) with Support Bar Bolts and Lock Nuts (2). (See Figure A.)

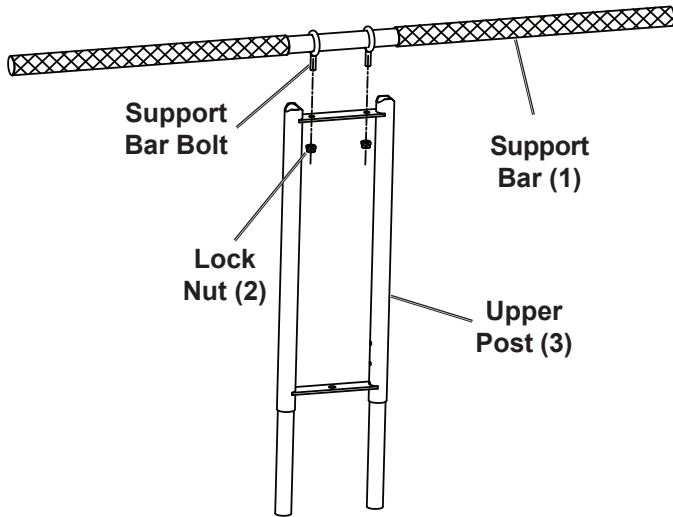

Figure A

2. Attach Casters (6) to ends of Bases A and B with Lock Nuts (4). (See Figure B.)

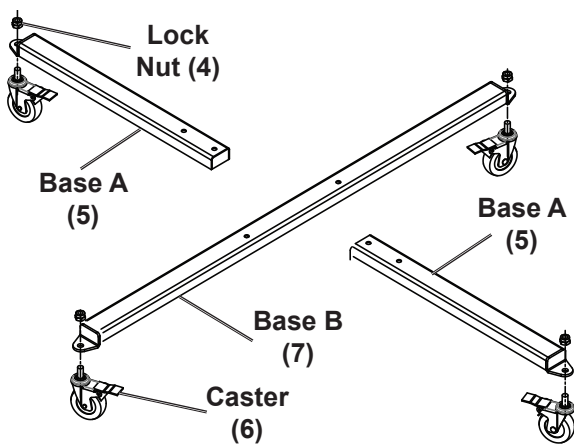

Figure B

3. Position Bases A and Base B so that bolt holes align with Lower Post (8) bolt holes. Secure with Hex Bolts (9) and Lock Nuts (2). (See Figure C.)

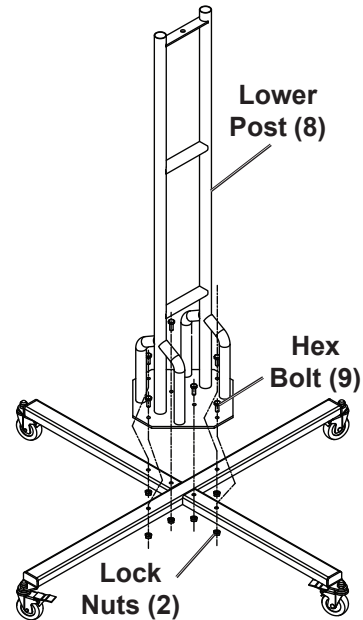

Figure C

4. Attach Upper Post assembly to Lower Post assembly, secure with Hex Bolt (10) and Lock Nut (2). (See Figure D.)

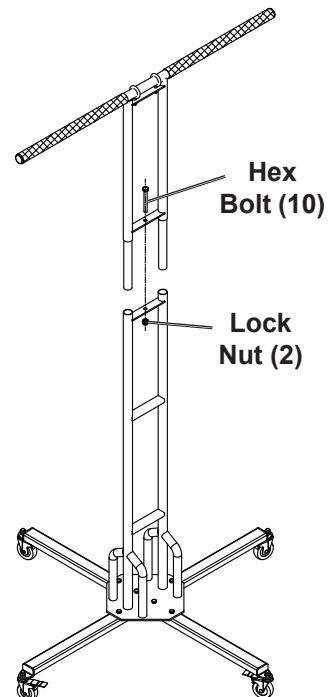

Figure D

Note: Before use, tighten all connections securely.

Operation



Read the **ENTIRE IMPORTANT SAFETY INFORMATION** section at the beginning of this document including all text under subheadings therein before set up or use of this product.

WARNING

TO PREVENT SERIOUS INJURY: Hanging and removal of bicycles should only be done by adults who are physically capable of safely lifting the weight of a bicycle.

CAUTION! TO PREVENT INJURY FROM TIPPING: Do not move with bicycles suspended. Remove bicycles before moving unit.

Note: Before use, tighten all connections securely.

Hanging Bicycles

1. Place Mobile Bike Storage unit in desired location, then engage caster locks by pushing down on levers.
2. Hang first bicycle by sliding tire over one side of Support Bar, positioning bicycle toward the center.
3. Hang next bicycle on other side of Support Bar with handle bars facing opposite first bicycle.
4. Hang subsequent bicycles in the same manner, making sure weight is evenly distributed at all times.

WARNING! TO PREVENT SERIOUS INJURY FROM PRODUCT FAILURE:
Do not exceed rated weight capacity.

Removing Bicycles

1. Firmly grip bicycle with both hands and slide off Support Bar.
2. Make sure evenly distributed weight is maintained.

Moving Unit

1. Remove bicycles then unlock casters.
2. Move unit to new location, then lock casters and replace bicycles.

Maintenance Instructions



Procedures not specifically explained in this manual must be performed only by a qualified technician.

!WARNING

TO PREVENT SERIOUS INJURY FROM TOOL FAILURE:

Do not use damaged equipment. If any part becomes damaged, have the problem corrected before further use.

Maintenance and Cleaning

1. **PERIODICALLY**, inspect the general condition of the unit. Check for:
 - loose hardware,
 - cracked or broken parts, and
 - any other condition that may affect its safe operation.
2. Wipe external surfaces of Mobile Bike Storage unit with clean cloth as needed.

PLEASE READ THE FOLLOWING CAREFULLY

THE MANUFACTURER AND/OR DISTRIBUTOR HAS PROVIDED THE PARTS LIST AND ASSEMBLY DIAGRAM IN THIS DOCUMENT AS A REFERENCE TOOL ONLY. NEITHER THE MANUFACTURER OR DISTRIBUTOR MAKES ANY REPRESENTATION OR WARRANTY OF ANY KIND TO THE BUYER THAT HE OR SHE IS QUALIFIED TO MAKE ANY REPAIRS TO THE PRODUCT, OR THAT HE OR SHE IS QUALIFIED TO REPLACE ANY PARTS OF THE PRODUCT. IN FACT, THE MANUFACTURER AND/OR DISTRIBUTOR EXPRESSLY STATES THAT ALL REPAIRS AND PARTS REPLACEMENTS SHOULD BE UNDERTAKEN BY CERTIFIED AND LICENSED TECHNICIANS, AND NOT BY THE BUYER. THE BUYER ASSUMES ALL RISK AND LIABILITY ARISING OUT OF HIS OR HER REPAIRS TO THE ORIGINAL PRODUCT OR REPLACEMENT PARTS THERETO, OR ARISING OUT OF HIS OR HER INSTALLATION OF REPLACEMENT PARTS THERETO.

Parts List

Part	Description	Qty
1	Support Bar	1
2	Lock Nut (M8)	9
3	Upper Post	1
4	Lock Nut (M10)	4
5	Base A	2
6	Locking Swivel Caster	4
7	Base B	1
8	Lower Post	1
9	Hex Bolt (M8x20)	6
10	Hex Bolt (M8x70)	1

Record Serial Number Here:

Note: If product has no serial number, record month and year of purchase instead.

Note: Some parts are listed and shown for illustration purposes only, and are not available individually as replacement parts.

Assembly Diagram

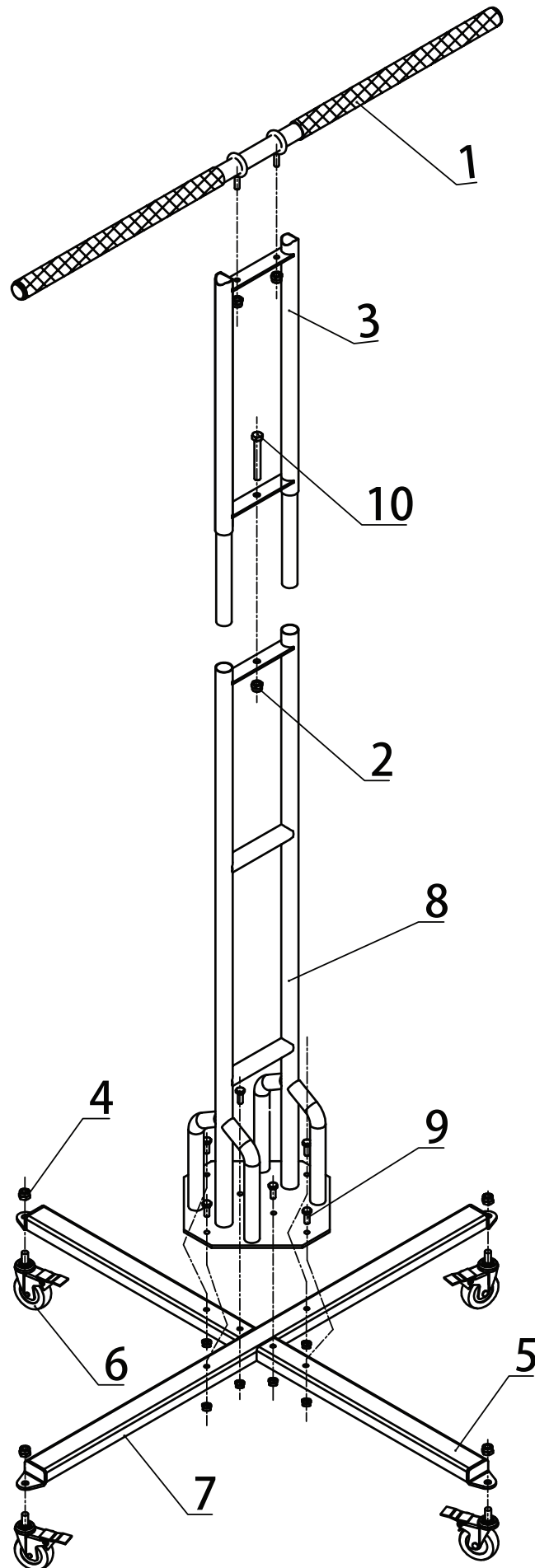

Limited 90 Day Warranty

Harbor Freight Tools Co. makes every effort to assure that its products meet high quality and durability standards, and warrants to the original purchaser that this product is free from defects in materials and workmanship for the period of 90 days from the date of purchase. This warranty does not apply to damage due directly or indirectly, to misuse, abuse, negligence or accidents, repairs or alterations outside our facilities, criminal activity, improper installation, normal wear and tear, or to lack of maintenance. We shall in no event be liable for death, injuries to persons or property, or for incidental, contingent, special or consequential damages arising from the use of our product. Some states do not allow the exclusion or limitation of incidental or consequential damages, so the above limitation of exclusion may not apply to you. THIS WARRANTY IS EXPRESSLY IN LIEU OF ALL OTHER WARRANTIES, EXPRESS OR IMPLIED, INCLUDING THE WARRANTIES OF MERCHANTABILITY AND FITNESS.

To take advantage of this warranty, the product or part must be returned to us with transportation charges prepaid. Proof of purchase date and an explanation of the complaint must accompany the merchandise. If our inspection verifies the defect, we will either repair or replace the product at our election or we may elect to refund the purchase price if we cannot readily and quickly provide you with a replacement. We will return repaired products at our expense, but if we determine there is no defect, or that the defect resulted from causes not within the scope of our warranty, then you must bear the cost of returning the product.

This warranty gives you specific legal rights and you may also have other rights which vary from state to state.