

Owner's Manual & Safety Instructions

Save This Manual Keep this manual for the safety warnings and precautions, assembly, operating, inspection, maintenance and cleaning procedures. Write the product's serial number in the back of the manual near the assembly diagram (or month and year of purchase if product has no number). Keep this manual and the receipt in a safe and dry place for future reference.

CENTRALPNEUMATIC®

soda blast conversion kit

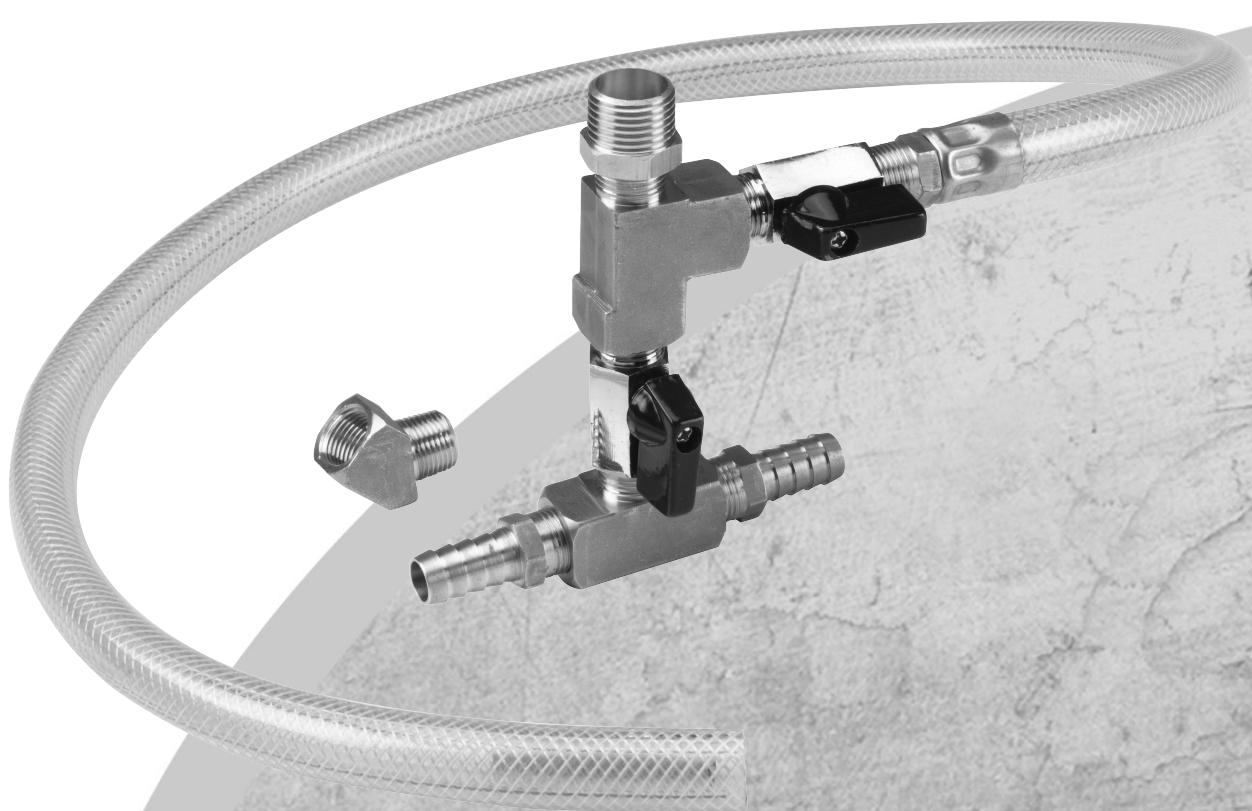

Abrasive Blaster required for operation, sold separately.

Visit our website at: <http://www.harborfreight.com>
Email our technical support at: tech@harborfreight.com

ITEM 60618

When unpacking, make sure that the product is intact and undamaged. If any parts are missing or broken, please call 1-800-444-3353 as soon as possible.

Copyright© 2012 by Harbor Freight Tools®. All rights reserved.
No portion of this manual or any artwork contained herein may be reproduced in any shape or form without the express written consent of Harbor Freight Tools. Diagrams within this manual may not be drawn proportionally. Due to continuing improvements, actual product may differ slightly from the product described herein. Tools required for assembly and service may not be included.

⚠ WARNING





**Read this material before using this product.
Failure to do so can result in serious injury.
SAVE THIS MANUAL.**

Table of Contents

Safety	2	Maintenance	10
Specifications	5	Parts List and Diagram	11
Setup	6	Warranty	12
Operation.....	8		

CENTRALPNEUMATIC®

WARNING SYMBOLS AND DEFINITIONS

	This is the safety alert symbol. It is used to alert you to potential personal injury hazards. Obey all safety messages that follow this symbol to avoid possible injury or death.
	Indicates a hazardous situation which, if not avoided, will result in death or serious injury.
	Indicates a hazardous situation which, if not avoided, could result in death or serious injury.
	Indicates a hazardous situation which, if not avoided, could result in minor or moderate injury.
	Addresses practices not related to personal injury.

IMPORTANT SAFETY INSTRUCTIONS

INSTRUCTIONS PERTAINING TO A RISK OF FIRE, ELECTRIC SHOCK, OR INJURY TO PERSONS

WARNING – When using tools, basic precautions should always be followed, including the following:



General

To reduce the risks of electric shock, fire, and injury to persons, read all the instructions before using the tool.

Work Area

- Keep the work area clean and well lit.**
Cluttered benches and dark areas increase the risks of electric shock, fire, and injury to persons.
- Do not operate the tool in explosive atmospheres, such as in the presence of flammable liquids, gases, or dust.** The tool is able to create sparks resulting in the ignition of the dust or fumes.
- Keep bystanders, children, and visitors away while operating the tool.** Distractions are able to result in the loss of control of the tool.

Personal Safety

1. **Stay alert. Watch what you are doing and use common sense when operating the tool. Do not use the tool while tired or under the influence of drugs, alcohol, or medication.**
A moment of inattention while operating the tool increases the risk of injury to persons.
2. **Avoid unintentional starting. Be sure the valves are closed before connecting to the air supply.** Do not connect the tool to the air supply with the valves open.
3. **Do not overreach. Keep proper footing and balance at all times.**
Proper footing and balance enables better control of the tool in unexpected situations.
4.  **Use safety equipment.**
A dust mask, non-skid safety shoes and a hard hat must be used for the applicable conditions.
5.  **Always wear eye protection.**
Wear ANSI-approved safety goggles.
6.  **Always wear hearing protection when using the tool.**
Prolonged exposure to high intensity noise is able to cause hearing loss.
7. **Wear heavy-duty work gloves during use.**

Tool Use and Care

1. **Use clamps or another practical way to secure and support the workpiece to a stable platform.**
Holding the work by hand or against the body is unstable and is able to lead to loss of control.
2. **Do not force the tool.** Use the correct tool for the application. The correct tool will do the job better and safer at the rate for which the tool is designed.
3. **Do not use the tool if the valves do not turn the tool on or off.** Any tool that cannot be controlled with the valves is dangerous and must be repaired.
4. **Disconnect the tool from the air source before making any adjustments, changing accessories, or storing the tool.** Such preventive safety measures reduce the risk of starting the tool unintentionally. Close all valves, detach the air supply, and pull on the safety valve to release all residual air pressure before leaving the work area.
5. **Store the tool when it is idle out of reach of children and other untrained persons.**
A tool is dangerous in the hands of untrained users.
6. **Maintain the tool with care.**
A properly maintained tool reduces the risk of binding and is easier to control.
7. **Check for misalignment or binding of moving parts, breakage of parts, and any other condition that affects the tool's operation.** If damaged, have the tool serviced before using. Many accidents are caused by poorly maintained tools. There is a risk of bursting if the tool is damaged.
8. **Use only accessories that are identified by the manufacturer for the specific tool model.** Use of an accessory not intended for use with the specific tool model, increases the risk of injury to persons.

Service

1. **Tool service must be performed only by qualified repair personnel.**
2. **When servicing a tool, use only identical replacement parts. Use only authorized parts.**
3. **Use only the lubricants supplied with the tool or specified by the manufacturer.**

Air Source

- 

Never connect to an air source that is capable of exceeding 200 psi. Over pressurizing the tool may cause bursting, abnormal operation, breakage of the tool or serious injury to persons.

Use only clean, dry, regulated compressed air at the rated pressure or within the rated pressure range as marked on the tool. Always verify prior to using the tool that the air source has been adjusted to the rated air pressure or within the rated air-pressure range.
- Never use oxygen, carbon dioxide, combustible gases or any bottled gas as an air source for the tool.** Such gases are capable of explosion and serious injury to persons.







SAVE THESE INSTRUCTIONS.

Symbols and Specific Safety Instructions

Symbol Definitions

Symbol	Property or statement
PSI	Pounds per square inch of pressure
CFM	Cubic Feet per Minute flow
SCFM	Cubic Feet per Minute flow at standard conditions
NPT	National pipe thread, tapered
NPS	National pipe thread, straight

Symbol	Property or statement
	WARNING marking concerning Risk of Eye Injury. Wear ANSI-approved eye protection.
	WARNING marking concerning Risk of Hearing Loss. Wear hearing protection.
	WARNING marking concerning Risk of Respiratory Injury. Wear NIOSH-approved dust mask/respirator.
	WARNING marking concerning Risk of Explosion.

Specific Safety Instructions

1. The warnings and precautions discussed in this manual cannot cover all possible conditions and situations that may occur. It must be understood by the operator that common sense and caution are factors which cannot be built into this product, but must be supplied by the operator.
2. Use this kit only with sodium bicarbonate blasting media (sold separately). Do not use any other blasting media. Especially do not use sand (crystalline silica) as a blasting media, it can cause serious respiratory disease.
3. **WARNING:** This product, when used for abrasive blasting and similar applications, produces chemicals known to the State of California to cause cancer and birth defects (or other reproductive harm). (California Health & Safety Code § 25249.5, *et seq.*)
4. **WARNING:** The brass components of this product contain lead, a chemical known to the State of California to cause birth defects (or other reproductive harm). (California Health & Safety code § 25249.5, *et seq.*)
5. Attach all accessories properly to the tool before connecting the air supply. A loose accessory may detach or break during operation.
6. Obey the manual for the air compressor and abrasive blaster used with this tool.
7. Install an in-line shutoff valve to allow immediate control over the air supply in an emergency, even if a hose is ruptured.

Vibration Precautions

This tool vibrates during use. Repeated or long-term exposure to vibration may cause temporary or permanent physical injury, particularly to the hands, arms and shoulders. To reduce the risk of vibration-related injury:

1. Anyone using vibrating tools regularly or for an extended period should first be examined by a doctor and then have regular medical check-ups to ensure medical problems are not being caused or worsened from use. Pregnant women or people who have impaired blood circulation to the hand, past hand injuries, nervous system disorders, diabetes, or Raynaud's Disease should not use this tool. If you feel any symptoms related to vibration (such as tingling, numbness, and white or blue fingers), seek medical advice as soon as possible.
2. Do not smoke during use. Nicotine reduces the blood supply to the hands and fingers, increasing the risk of vibration-related injury.
3. Wear suitable gloves to reduce the vibration effects on the user.
4. Use tools with the lowest vibration when there is a choice.
5. Include vibration-free periods each day of work.
6. Grip tool as lightly as possible (while still keeping safe control of it). Let the tool do the work.
7. To reduce vibration, maintain tool as explained in this manual. If abnormal vibration occurs, stop immediately.



SAVE THESE INSTRUCTIONS.

Functional Description

Specifications

Working Air Pressure	80 PSI
Tank (Top) Connector	3/8" or 1/2"

Initial Tool Set Up/Installation



Read the **ENTIRE IMPORTANT SAFETY INFORMATION** section at the beginning of this manual including all text under subheadings therein before set up or use of this product.

Note: For additional information regarding the parts listed in the following pages, refer to the Assembly Diagram near the end of this manual.

Note: This air tool is shipped with a protective plug covering the inlet. Remove this plug before set up.

Installation

Note: Abrasive Blaster required for operation, sold separately.

1. Close air supply valve, disconnect air supply from Abrasive Blaster, and release all pressure from its Tank by pulling the safety valve.

2. Empty all abrasive media from the Abrasive Blaster and its hoses.

Note: Any remaining abrasive media may cause clogging and/or undesirable results.

3. Disconnect the Abrasive Valve Assembly's three connections as listed below and shown in Figure A:
- Air Hose Connection
 - Tank Connection
 - Abrasive Hose Connection

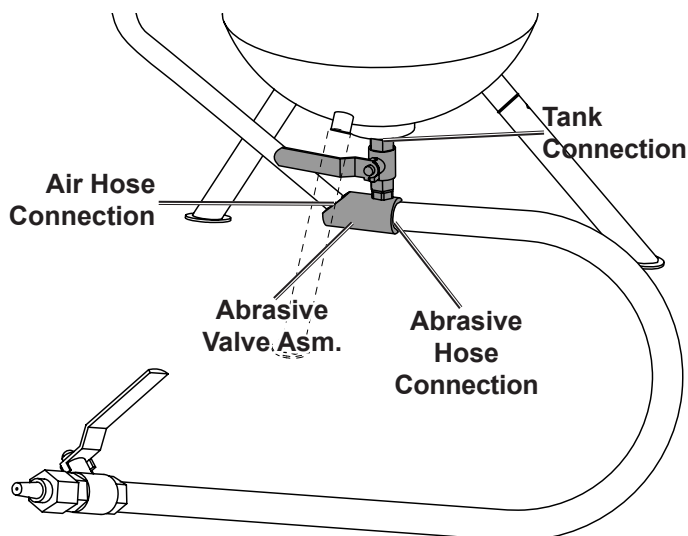

Figure A: Disconnect Three Abrasive Valve Asm. Connections
(Item 68994 shown for reference.)

4. Clean disconnected hose ends and threads leading into the tank. Remove all thread seal tape from threads and chase threads if needed.
5. Remove the Cover (1) from the top of the Service Tee (2).
6. Wrap the threads on the top of the Service Tee (2) with at least three wraps of thread seal tape (sold separately).

7. Thread the Service Tee (2) into the bottom of the Tank by hand as far as possible, then wrench tighten it.

8. The Hose Barb Fitting (8) that is angled upward is used to attach a plain Air Hose. Secure this connection using a Hose Clamp (sold separately).

Note: For an Air Hose with a threaded fitting:

- Unthread and remove the Hose Barb Fitting (8).
- Wrap the threads on the end of the Air Hose with at least three wraps of thread seal tape (sold separately).
- Thread the Air Hose into the 45° Elbow (9) by hand as far as possible, then wrench tighten it.

9. Slip the Abrasive Hose over the Hose Barb Fitting (8), and secure it with a Hose Clamp (sold separately).

10. Wrap the threads on the end of the Purge Hose (10) with at least three wraps of thread seal tape (sold separately).

11. Thread the Purge Hose (10) into the Ball Valve (5) by hand as far as possible, then wrench tighten it.

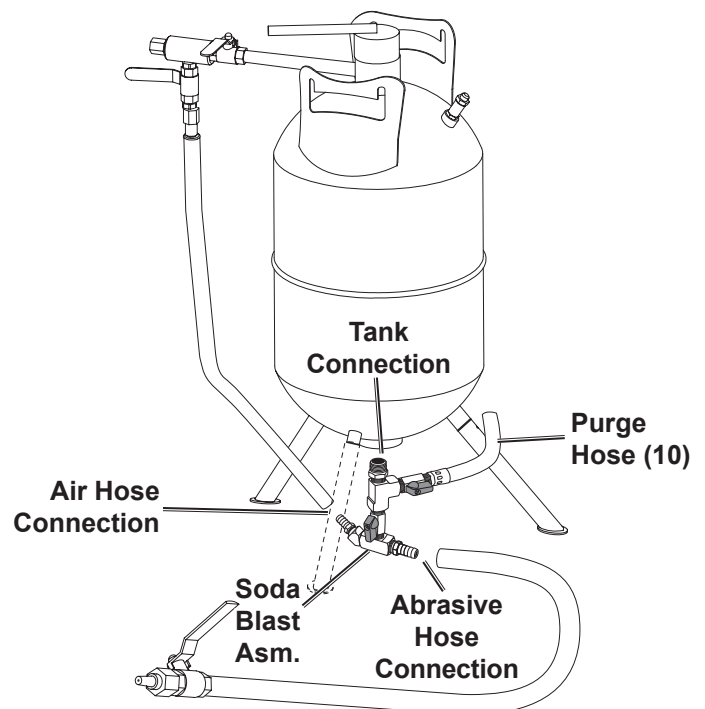

Figure B: Kit Installation

Air Supply

⚠ WARNING



TO PREVENT SERIOUS INJURY FROM EXPLOSION:
Use only clean, dry, regulated, compressed air to power this tool.
Do not use oxygen, carbon dioxide, combustible gases,
or any other bottled gas as a power source for this tool.

NOTE: A DRY, OIL-FREE AIR SUPPLY IS CRITICAL.

Moist or lubricated air will quickly clog the blaster and render it unusable.

1. Incorporate a filter, regulator with pressure gauge, dryer, in-line shutoff valve, and quick coupler for best service, as shown on Figure C.
An in-line shutoff ball valve is an important safety device because it controls the air supply even if the air hose is ruptured. The shutoff valve should be a ball valve because it can be closed quickly.
2. Attach an air hose to the compressor's air outlet. Connect the air hose to the air inlet of the tool. Other components, such as a coupler plug and quick coupler, will make operation more efficient, but are not required.
3. Close the tool's Trigger Valve. Open all of the tool's other valves.
4. Turn on the air compressor according to the manufacturer's directions and allow it to build up pressure until it cycles off.
5. Adjust the air compressor's output regulator so that the air output is enough to properly power the tool, but the output will not exceed the tool's maximum air pressure at any time. Adjust the pressure gradually, while checking the air output gauge to set the right pressure range.
6. Inspect the air connections for leaks. Repair any leaks found.
7. If the tool will not be used at this time, close all valves, detach the air supply, and pull on the safety valve to release all residual air pressure to prevent accidental operation.

Note: An oiler system should not be used with this tool. The oil will mix with the material being propelled, causing poor results.

Note: Air flow, and therefore tool performance, can be hindered by undersized air supply components.

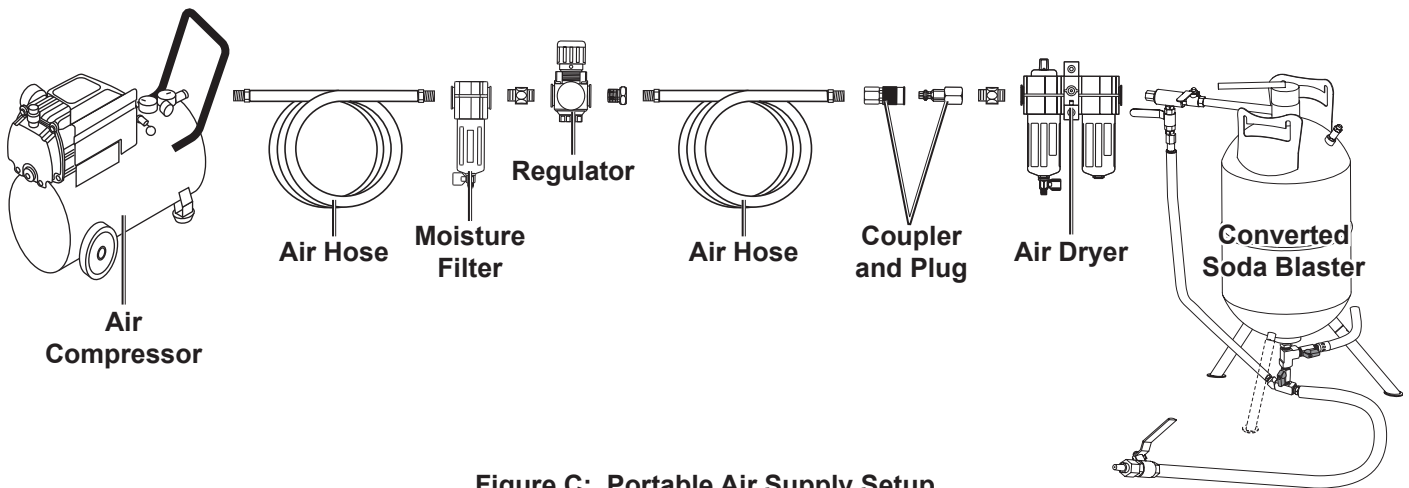

Figure C: Portable Air Supply Setup

CENTRALPNEUMATIC®

Operating Instructions



Read the **ENTIRE IMPORTANT SAFETY INFORMATION** section at the beginning of this manual including all text under subheadings therein before set up or use of this product.

Inspect tool before use, looking for damaged, loose, and missing parts.
If any problems are found, do not use tool until repaired.

Tool Set Up - Filling Soda Blasting Media

⚠️WARNING

TO PREVENT SERIOUS INJURY FROM ACCIDENTAL OPERATION:

Close all valves, detach the air supply, and pull on the safety valve to release all residual air pressure before performing any inspection, maintenance, or cleaning procedures.

TO PREVENT SERIOUS INJURY:

Do not adjust or tamper with any control or component in a way not specifically explained within this manual. Improper adjustment can result in tool failure or other serious hazards.

IMPORTANT: Fill tank immediately before use and do not allow media to sit in the blaster. It will solidify in the tank, becoming very difficult to remove.

1. Open the Tank.

Note: Household baking soda is NOT blasting media.

2. Use a funnel and screen filter to fill the Tank with sodium bicarbonate blasting media (all sold separately).

Note: Using DRY media only and SCREENING when filling are both CRITICAL to prevent severe clogging.

3. Close the Tank securely.

Workpiece and Work Area Set Up

1. Designate a work area that is clean and well-lit. The work area must not allow access by children or pets to prevent distraction and injury.
2. Route the air hose along a safe route to reach the work area without creating a tripping hazard or exposing the air hose to possible damage.
3. Secure loose workpieces using a vise or clamps (not included) to prevent movement while working.
4. There must not be hazardous objects (such as utility lines or foreign objects) nearby that will present a hazard while working.
5. Keep a large bucket and blanket nearby to assist with purging unused media after use.

CENTRALPNEUMATIC®

General Operating Instructions

1. Connect the air hose, from the moisture- and oil-free air supply, as explained earlier, and adjust air supply within operating PSI.
2. Close the Purge Valve and the Trigger Valve completely.
3. Open the Air Valve.
4. Open the Throttle Valve about halfway for now. This may require adjustment later for optimal performance.
5. Slowly open the Abrasive Valve completely.
6. Direct the Nozzle at the work surface and open the Trigger Valve to start blasting.

Note: Media flow will be intermittent at first.

7. As needed, adjust the Throttle Valve to optimize operation.
8. **If media clumps and flow stops:**
 - a. Close the Trigger Valve.
 - b. Hold the end of the Purge Hose in the large bucket and cover it with a blanket.
 - c. Quickly open and close the Purge Valve to clear the clog.
 - d. If clog is cleared, continue working. If clog is not cleared, try closing the Throttle Valve, directing the Nozzle at a piece of scrap material, and opening the Trigger Valve to clear the clog.
 - e. If clog cannot be cleared any other way, close all Valves, disconnect air supply and open Air Valve to release air pressure, then disassemble components and clean them out.

TO PREVENT CLOGGING:

- **USE A DRY, OIL-FREE AIR SUPPLY.**
- **USE DRY, FRESH SODIUM BICARBONATE BLASTING MEDIA ONLY.** Household baking soda is **NOT** blasting media.
- **SCREEN MEDIA WHEN FILLING.**

ANY moisture or oil will quickly clog the blaster and render it unusable.

9. **To REFILL media as needed:**
 - a. Close the Air, Throttle, Abrasive, and Trigger Valves.
 - b. Disconnect air supply and open Air Valve to release air pressure.
 - c. Refill media according to the instructions on page 8.
 - d. Reconnect air supply and restart use at Step 4.

10. **PREVENT CLOGGING. PURGE media after use:**
 - a. Leave the Air Valve open and close the Throttle, Abrasive, and Trigger Valves.
 - b. Direct the end of the Purge Hose into the large bucket, and cover it with a blanket. Hold the Purge Hose while opening the Purge Valve slowly and completely until all of the media has drained out.
 - c. Close the Purge Valve. Leave the Purge Hose in the bucket and the bucket covered for a few minutes.
 - d. Open the Throttle and Abrasive Valves.
 - e. Direct the Nozzle at a piece of scrap material and open the Trigger Valve to expel any media remaining in the Hose.
 - f. Close the Air, Throttle, Abrasive, and Trigger Valves.
 - g. Disconnect air supply and open Air Valve to release air pressure, then close it.
11. Vacuum and/or sweep up all dust after use.
12. Store the tool indoors out of children's reach.
13. After blasting, parts will have a thin coating that will help inhibit rust temporarily. This coating needs to be washed off with a wet cloth before painting.

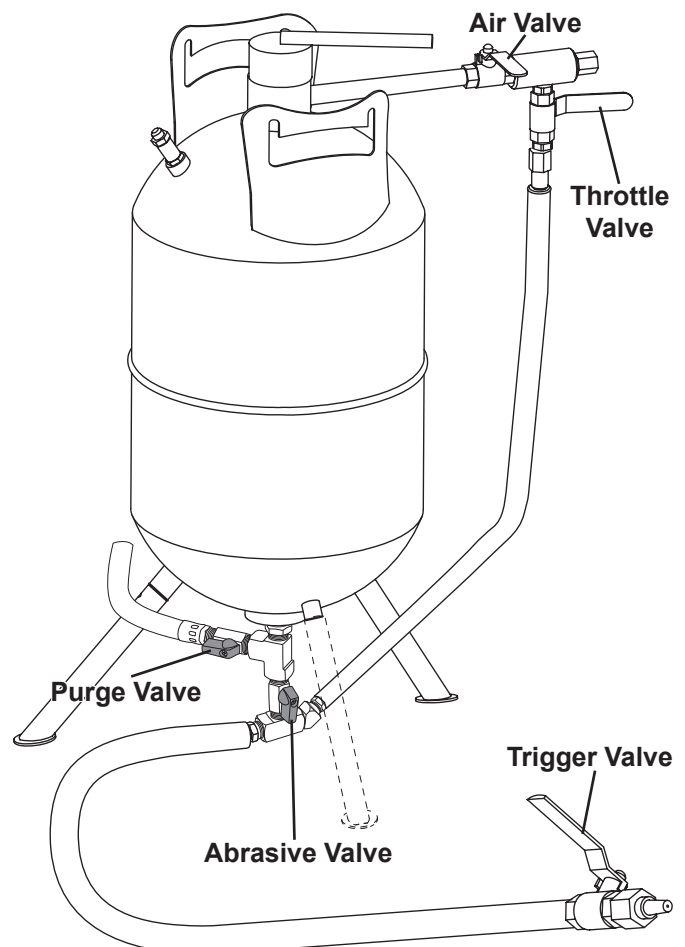

Figure D: Components and Controls

User-Maintenance Instructions



Procedures not specifically explained in this manual must be performed only by a qualified technician.

WARNING

TO PREVENT SERIOUS INJURY FROM ACCIDENTAL OPERATION:

Close all valves, detach the air supply, and pull on the safety valve to release all residual air pressure before performing any inspection, maintenance, or cleaning procedures.

TO PREVENT SERIOUS INJURY FROM TOOL FAILURE:

Do not use damaged equipment. If abnormal noise, vibration, or leaking air occurs, have the problem corrected before further use.

Cleaning, Maintenance, and Lubrication

Note: These procedures are in addition to the regular checks and maintenance explained as part of the regular operation of the air-operated tool.

- BEFORE EACH USE**, inspect the general condition of the tool. Check for:
 - loose hardware or housing,
 - misalignment or binding of moving parts,
 - cracked or broken parts, and
 - any other condition that may affect its safe operation.
- Daily - Air Supply Maintenance:**
Every day, maintain the air supply according to the component manufacturers' instructions. Drain the moisture filter regularly. Performing routine air supply maintenance will allow the tool to operate more safely and will also reduce wear on the tool.

Troubleshooting

Problem	Possible Causes	Likely Solutions
Decreased output.	<ol style="list-style-type: none">1. Not enough air pressure and/or air flow.2. Blocked air inlet screen (if equipped).3. Air leaking from loose housing.4. Mechanism contaminated.	<ol style="list-style-type: none">1. Check for loose connections and make sure that air supply is providing enough air flow (CFM) at required pressure (PSI) to the tool's air inlet. Do not exceed maximum air pressure.2. Clean air inlet screen of buildup.3. Make sure housing is properly assembled and tight.4. Have qualified technician clean mechanism. Install in-line filter in air supply as stated in Setup: Air Supply on page 7.
Severe air leakage. (Slight air leakage is normal, especially on older tools.)	<ol style="list-style-type: none">1. Cross-threaded housing components.2. Loose housing.3. Damaged valve or housing.4. Dirty, worn or damaged valve.	<ol style="list-style-type: none">1. Check for incorrect alignment and uneven gaps. If cross-threaded, disassemble and replace damaged parts before use.2. Tighten housing assembly. If housing cannot tighten properly, internal parts may be misaligned. Technician needs to disassemble tool, align parts and reassemble.3. Replace damaged components.4. Clean or replace valve assembly.



Follow all safety precautions whenever diagnosing or servicing the tool. Disconnect air supply before service.

PLEASE READ THE FOLLOWING CAREFULLY

THE MANUFACTURER AND/OR DISTRIBUTOR HAS PROVIDED THE PARTS LIST AND ASSEMBLY DIAGRAM IN THIS MANUAL AS A REFERENCE TOOL ONLY. NEITHER THE MANUFACTURER OR DISTRIBUTOR MAKES ANY REPRESENTATION OR WARRANTY OF ANY KIND TO THE BUYER THAT HE OR SHE IS QUALIFIED TO MAKE ANY REPAIRS TO THE PRODUCT, OR THAT HE OR SHE IS QUALIFIED TO REPLACE ANY PARTS OF THE PRODUCT. IN FACT, THE MANUFACTURER AND/OR DISTRIBUTOR EXPRESSLY STATES THAT ALL REPAIRS AND PARTS REPLACEMENTS SHOULD BE UNDERTAKEN BY CERTIFIED AND LICENSED TECHNICIANS, AND NOT BY THE BUYER. THE BUYER ASSUMES ALL RISK AND LIABILITY ARISING OUT OF HIS OR HER REPAIRS TO THE ORIGINAL PRODUCT OR REPLACEMENT PARTS THERETO, OR ARISING OUT OF HIS OR HER INSTALLATION OF REPLACEMENT PARTS THERETO.

Part	Description	Qty
1	Cover	1
2	Service Tee	1
3	Ceramic Nozzle	1
4	O-ring	1
5	Ball Valve	2

Part	Description	Qty
6	Male Branch Tee	1
7	3/8" to 1/2" Adapter	1
8	Hose Barb Fitting	2
9	45° Elbow	1
10	Purge Hose	1

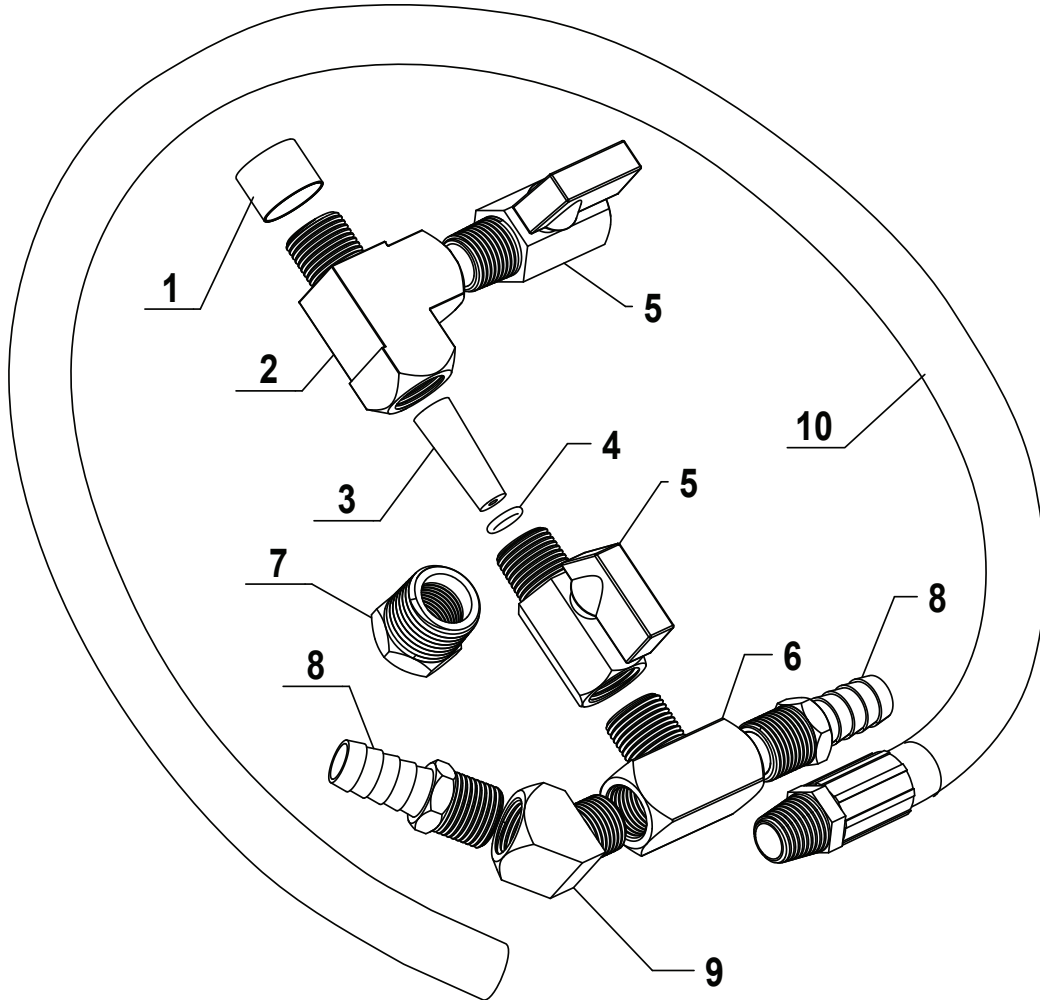

Record Product's Serial Number Here: _____

Note: If product has no serial number, record month and year of purchase instead.

Note: Some parts are listed and shown for illustration purposes only, and are not available individually as replacement parts.

Limited 90 Day Warranty

Harbor Freight Tools Co. makes every effort to assure that its products meet high quality and durability standards, and warrants to the original purchaser that this product is free from defects in materials and workmanship for the period of 90 days from the date of purchase. This warranty does not apply to damage due directly or indirectly, to misuse, abuse, negligence or accidents, repairs or alterations outside our facilities, criminal activity, improper installation, normal wear and tear, or to lack of maintenance. We shall in no event be liable for death, injuries to persons or property, or for incidental, contingent, special or consequential damages arising from the use of our product. Some states do not allow the exclusion or limitation of incidental or consequential damages, so the above limitation of exclusion may not apply to you. THIS WARRANTY IS EXPRESSLY IN LIEU OF ALL OTHER WARRANTIES, EXPRESS OR IMPLIED, INCLUDING THE WARRANTIES OF MERCHANTABILITY AND FITNESS.

To take advantage of this warranty, the product or part must be returned to us with transportation charges prepaid. Proof of purchase date and an explanation of the complaint must accompany the merchandise. If our inspection verifies the defect, we will either repair or replace the product at our election or we may elect to refund the purchase price if we cannot readily and quickly provide you with a replacement. We will return repaired products at our expense, but if we determine there is no defect, or that the defect resulted from causes not within the scope of our warranty, then you must bear the cost of returning the product.

This warranty gives you specific legal rights and you may also have other rights which vary from state to state.

CENTRALPNEUMATIC®

3491 Mission Oaks Blvd. • PO Box 6009 • Camarillo, CA 93011 • (800) 444-3353