

T-POST LIFTER

Model 38444

ASSEMBLY & OPERATING INSTRUCTIONS



3491 Mission Oaks Blvd. / Camarillo, CA 93011

Copyright © 1998 by Harbor Freight Tools. All rights reserved.
No portion of this manual or any artwork contained herein may be reproduced in any shape or form without the express written consent of Harbor Freight Tools.

For technical questions and replacement parts, please call 1-800-444-3353.

Revised 03/07

THANK YOU for choosing a **HARBOR FREIGHT TOOLS** product. For future reference, please complete the owner's record below:

Model _____ **Serial No** _____ **Purchase Date** _____

SAVE THE RECEIPT, WARRANTY AND THESE INSTRUCTIONS. It is important that you read the entire manual to become familiar with the unit BEFORE you begin assembly.



READ ALL INSTRUCTIONS BEFORE USING THIS PRODUCT!

The Operator

COMMON SENSE AND CAUTION ARE FACTORS WHICH CANNOT BE BUILT INTO ANY PRODUCT. THESE FACTORS MUST BE SUPPLIED BY THE OPERATOR. PLEASE REMEMBER:

Do not use the product if under the influence of alcohol or drugs. Read warning labels on prescriptions to determine if your judgment/reflexes might be impaired.

Do not wear loose clothing or jewelry as they can be caught in moving parts.

Protective gloves and non-skid footwear is recommended.

Use eye and ear protection. Always wear: ANSI-approved impact safety goggles.

Maintain proper footing and balance at all times.

Work Area

TO AVOID RISK OF PERSONAL INJURY, EQUIPMENT DAMAGE, FIRE AND SHOCK, MAKE SURE YOUR **WORK AREA** IS:

Free of damp, wet or rainy conditions

Free of children (never let them handle tools or machinery)

Well-lit

Clean and uncluttered

Before Operating

Before using any tool, any part that appears damaged should be carefully checked to determine that it will operate properly and perform its intended function.

Before using your T-Post Lifter check for damaged parts. You should also make sure all clamps, locks and bolts are tight.

IF THERE IS ANY QUESTION ABOUT A CONDITION BEING SAFE OR UNSAFE, DO NOT OPERATE THE TOOL.

Technical Specifications

Tool Name: T-Post Lifter
SKU: 38444
Base Dimensions: 37 1/2" x 1 3/4" x 7/64"
Base: 34" x 1" x 1/8" Thick Steel Tubing
Weight: 10 Lbs.

Product Use: The T-Post Lifter lifts up used T-Posts with ease, even from hard or frozen ground.

Assembly

Step 1) Attach Handle (part #3) to Base (part #1) by inserting the Axle (part #7) into the Base and through the holes in the Handle. Insert Cotter Pin (part # 6) into Axle to firmly secure Handle (See Parts Diagram below).

Step 2) Line up the upper circular tube portion of U-Block (part #2) with tubing at the top of the Handle (part #3). Insert the Shaft (part # 5) through the Washer (part # 4) and secure with the Cotter Pin (part # 6) (See Parts Diagram below).

Operation

Making sure Base (part #1) is stable, insert T-Post into open end of U-Block (part #2). Push down on Handle to pull up T-Post.

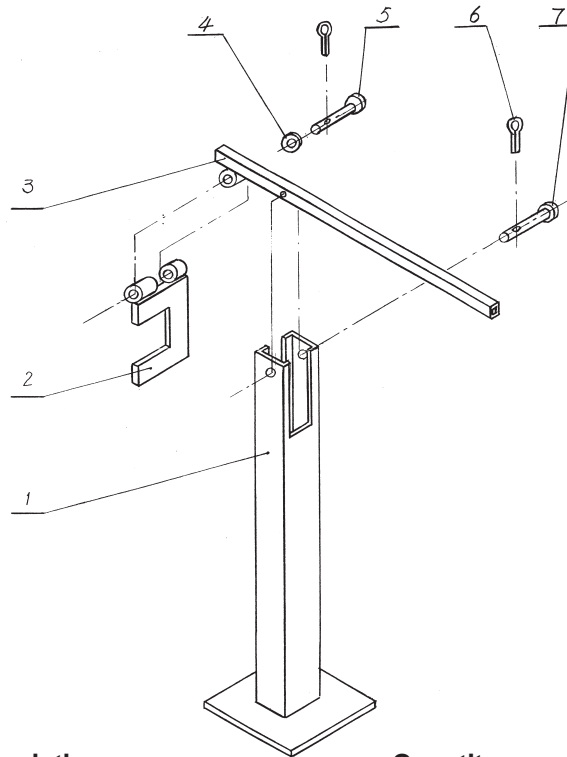

Parts List

Part Number	Description	Quantity
1	Base	1
2	U - Block	1
3	Handle	1
4	Washer	1
5	Shaft	1
6	Cotter Pin	2
7	Axle	1