

# JBL® ONBEAT XTREME™

iPod, iPhone and iPad docking speaker dock with Bluetooth



Made for  
iPod iPhone iPad

**OWNER'S MANUAL**

## INTRODUCTION

The JBL® OnBeat Xtreme™ speaker dock provides the ultimate in high-quality sound for your iPod, iPhone, iPad or other *Bluetooth*®-enabled devices. Built-in *Bluetooth* technology lets you play and control your music wirelessly from anywhere within a 30-foot radius. You can wirelessly stream high-quality audio from Internet radio and even handle phone calls. The JBL OnBeat Xtreme unit's rotating dock connector lets you orient your iPod, iPhone, or iPad device with its screen in portrait or landscape mode, and the included USB cable connects the JBL OnBeat Xtreme dock to your computer so you can charge and synchronize your iPod, iPhone, or iPad device with your iTunes library.

## COMPATIBILITY

The JBL OnBeat Xtreme system is compatible with most *Bluetooth*-enabled devices, music players, cell phones and laptops. Enabled with *Bluetooth* A2DP (Advanced Audio Distribution Profile), AVRCP (Audio/Video Remote Control Profile) and HFP (Hands-Free Profile), the system can stream high-quality sound and serve as a speakerphone. The stereo Aux connection also lets you enjoy high-quality audio from a variety of devices such as MP3 and CD players, desktop computers (all platforms), laptops and satellite radio tuners.

## INCLUDED ITEMS

Carefully unpack your speaker dock, and confirm that all the items shown here are included: JBL OnBeat Xtreme speaker dock, AC power cord\*, remote control, iPod touch/iPhone adapter clip, iPad adapter clip, USB cable and 3.5mm stereo audio cable.

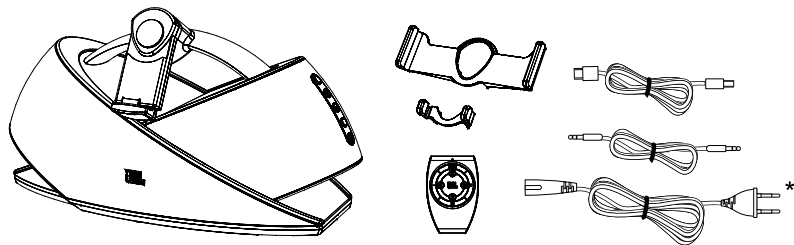

\*AC cord varies by region

## CONNECTIONS

### ATTACH THE iPod/iPhone/iPad ADAPTER CLIP

Your JBL OnBeat Xtreme speaker dock includes two adapter clips: one for an iPod touch/iPod classic/iPhone device, and another for an iPad device (**NOTE:** the iPod 5G and iPod nano models do not require an adapter clip.)

Attach the appropriate adapter clip to the JBL OnBeat Xtreme unit as shown below. Rotate the rubber end caps as shown to accommodate different model iPad devices and units with third-party skins.

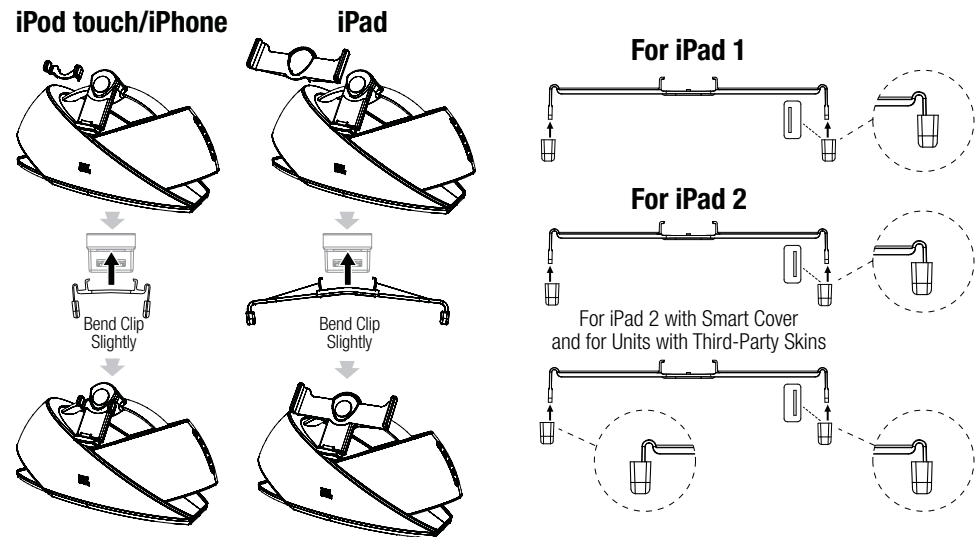

## CONNECT AN AUXILIARY DEVICE

If you are going to use your JBL OnBeat Xtreme system with another audio source, plug one end of the supplied 3.5mm (1/8") stereo cable into the JBL OnBeat Xtreme Aux In connector, and plug the other end into the audio source's audio out or headphone out connector.

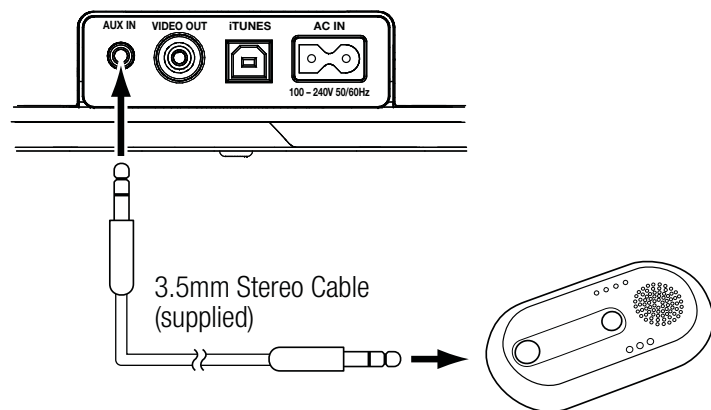

## CONNECT TO A TV

If you want to view videos or photos from your iPod, iPhone or iPad device on a TV, plug one end of a composite video cable (not supplied) into the JBL OnBeat Xtreme Video Out connector, and plug the other end into your TV's composite video input connector.

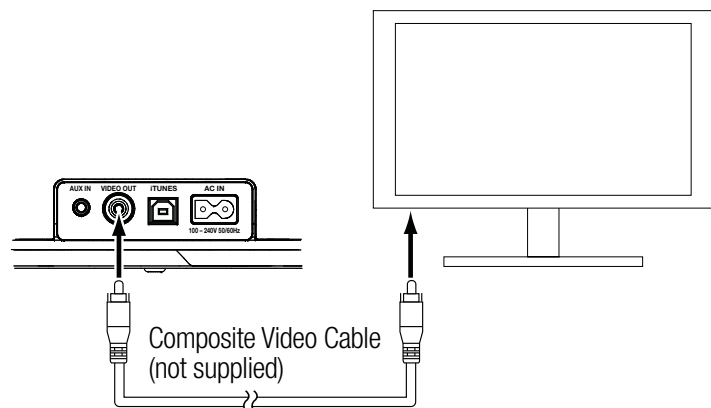

## CONNECT TO iTunes

Connect the supplied USB Type Mini B cable to the JBL OnBeat Xtreme USB port and to a USB port on the computer on which your iTunes library is located. This allows you to sync a docked iPod/iPhone/iPad device with iTunes (see *Synchronizing with iTunes*, on page 10).

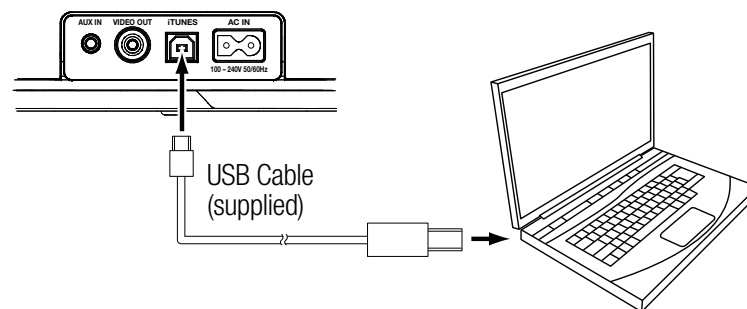

## CONNECT POWER

Insert the supplied AC cord into the JBL OnBeat Xtreme AC In connector and plug it into a working AC wall outlet.

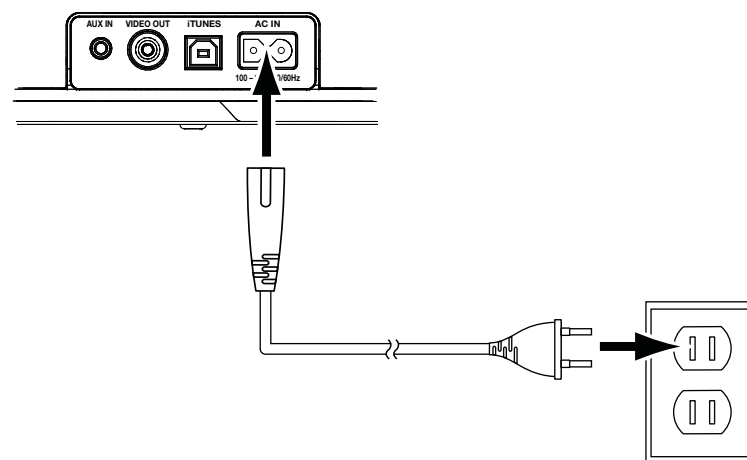

## USING YOUR JBL ONBEAT XTREME CONTROLS

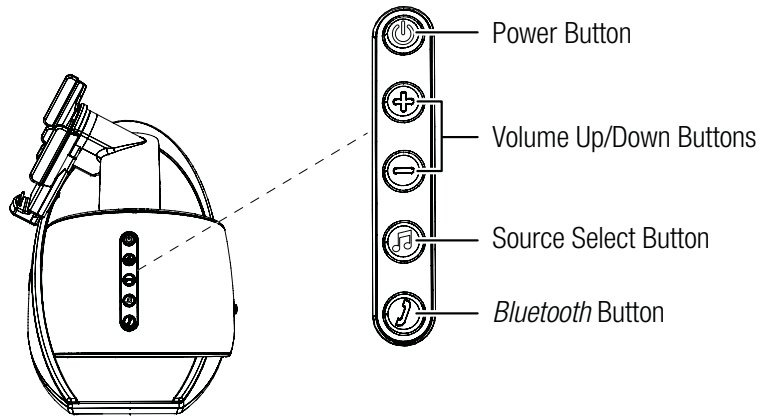

**Power button:** Press this button to turn the JBL OnBeat Xtreme on. The Power Button LED will glow white. When the system is on, press this button to place the system in the sleep mode. The LED will glow amber.

**NOTE:** Pressing the Power button will also place a docked device into its sleep mode. The JBL OnBeat Xtreme will automatically enter the sleep mode whenever no control buttons have been pressed and no audio signal has been present for 10 minutes.

**Volume Up/Down buttons:** Press these buttons to raise and lower the volume. Press both buttons simultaneously to mute or unmute the volume.

**Source Select button:** Press this button to cycle through the audio sources: *Bluetooth*, iPod/iPhone/iPad dock, Auxiliary input. The Source Select LED changes color to indicate which audio source is selected. See *Power and Source Select LEDs* on page 9.

**Bluetooth button:** Press this button to answer a phone call and perform other *Bluetooth* functions. See *Bluetooth Pairing*, on page 6; and *Receiving a Phone Call from a Bluetooth-enabled Device*, and *Placing a Phone Call from a Bluetooth-enabled Device*, on page 7.

## REMOTE CONTROL FUNCTIONS

You can use the JBL OnBeat Xtreme remote control to power on and off the JBL OnBeat Xtreme unit, change the volume, select music from your docked device, change the audio source and change the EQ settings.

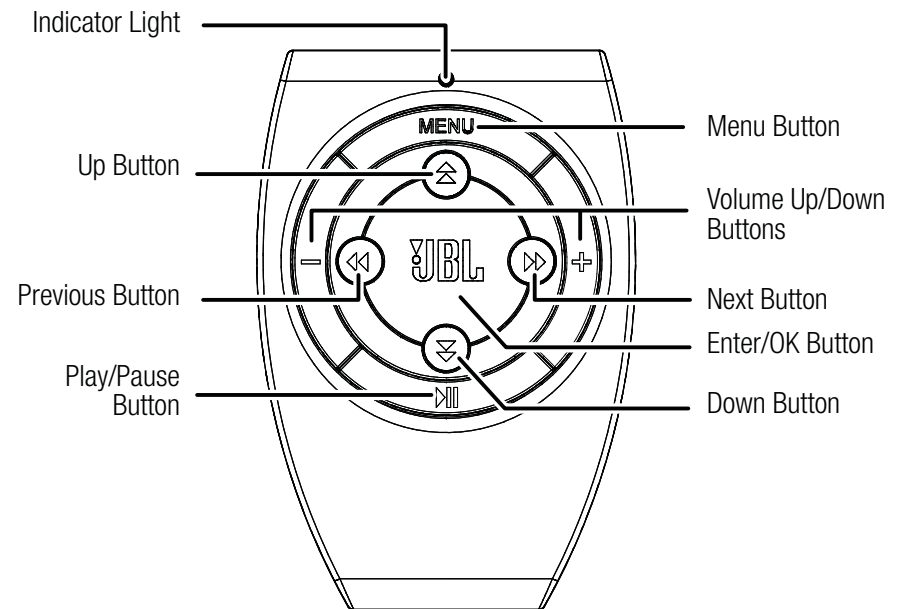

Remote Control Button	Action	Function
Enter/OK	Short press	Confirms a selection.
	Long press	Changes the EQ setting (see <i>EQ Settings</i> , on page 9, for details).
Menu	Short press	Acts as the menu button on the docked device.
	Long press	Changes the audio source from the docked device, to <i>Bluetooth</i> , to the auxiliary device.
Volume Down*	Short press	<ul style="list-style-type: none"> <li>• If the audio is not muted, each press lowers the volume by an increment of 1 (in a range of 1-30).</li> <li>• If the audio is muted, this restores audio to the level prior to muting.</li> </ul>
	Long press	Continuously lowers the volume.
Volume Up*	Short press	<ul style="list-style-type: none"> <li>• If the audio is not muted, each press raises the volume by an increment of 1 (in a range of 1-30).</li> <li>• If the audio is muted, this restores audio to the level prior to muting.</li> </ul>
	Long press	Continuously raises the volume.
Play/Pause	Short press	Play/pause music or video.
	Long press	<ul style="list-style-type: none"> <li>• If the JBL OnBeat Xtreme is in the sleep mode, this turns the unit on.</li> <li>• If the JBL OnBeat Xtreme is on, this puts the unit in the sleep mode.</li> </ul>
Left	Short press	Changes to the previous audio or video track.
	Long press	Rewinds the audio or video.
Right	Short press	Changes to the next audio or video track.
	Long press	Fast-forwards through the audio or video track.
Up	Short press	Scroll up.
Down	Short press	Scroll down.

\*Press the Volume Up and Volume Down buttons simultaneously to mute and unmute the volume.

## BLUETOOTH PAIRING

Before you can use your JBL OnBeat Xtreme system with a *Bluetooth*-enabled device, you must pair it with that device.

**NOTE:** The maximum distance for *Bluetooth* functionality is approximately 30 feet.

To pair the JBL OnBeat Xtreme system with your device:

1. Make sure your JBL OnBeat Xtreme system is turned on (the Power LED glows white).
2. To place the JBL OnBeat Xtreme unit in *Bluetooth* Pairing/Discoverable mode, press the Source Select button until the LED flashes blue.

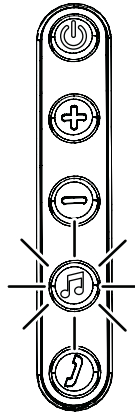

3. Put your *Bluetooth*-enabled device in Pairing mode so both devices can “see” each other. (Refer to the *Bluetooth*-enabled device’s user’s guide for directions and details about putting it into Pairing mode.) The JBL OnBeat Xtreme unit will be represented as JBL OnBeat Xtreme on your *Bluetooth*-enabled device.

4. If prompted by your device, enter the JBL OnBeat Xtreme password, which is **0000**.

5. The JBL OnBeat Xtreme system is successfully paired and ready to use when the Source Select button stops flashing and glows blue.

**NOTE:** *Bluetooth* pairing between two devices does not have to be repeated after a successful initial pairing unless the JBL OnBeat Xtreme system has been removed from the *Bluetooth*-enabled device’s *Bluetooth* device list or the JBL OnBeat Xtreme’s power cord has been disconnected. While the JBL OnBeat Xtreme is in the *Bluetooth*-connected mode you can force the unit into the *Bluetooth* pairing mode by pressing the Source Select button for at least two seconds.

## LISTENING TO MUSIC FROM A BLUETOOTH-ENABLED DEVICE

1. Make sure the JBL OnBeat Xtreme system is paired with your *Bluetooth*-enabled device (see *Bluetooth Pairing*, at left).
2. Make sure the JBL OnBeat Xtreme system is in *Bluetooth* mode (the Source Select LED glows blue).
3. Go to the *Bluetooth*-enabled device’s music player and play music. Refer to the *Bluetooth*-enabled device’s user’s guide for directions and details about using its music player and transmitting music via *Bluetooth* technology.
4. Use the *Bluetooth*-enabled device to navigate the music player.

## RECEIVING A PHONE CALL FROM A BLUETOOTH-ENABLED DEVICE

1. Make sure the JBL OnBeat Xtreme system is paired (see *Bluetooth Pairing*, on page 6).
2. When you hear your *Bluetooth*-enabled device's ringtone from the JBL OnBeat Xtreme system, press the *Bluetooth* button to answer the phone call.
  - To reject an incoming phone call: Press and hold the *Bluetooth* button on the JBL OnBeat Xtreme unit for two seconds.
  - To accept a second incoming phone call while putting the first call on hold: Press the *Bluetooth* button.
  - To reject a second incoming phone call while staying on the first call: Press and hold the *Bluetooth* button on the JBL OnBeat Xtreme for two seconds.

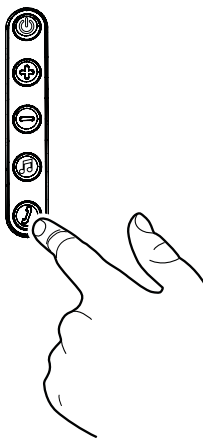

- To mute a phone call: Press both Volume buttons on the JBL OnBeat Xtreme system. To unmute the phone call: Press either Volume button on the JBL OnBeat Xtreme unit.

The JBL OnBeat Xtreme system's built-in microphone lets you use it as a speakerphone.

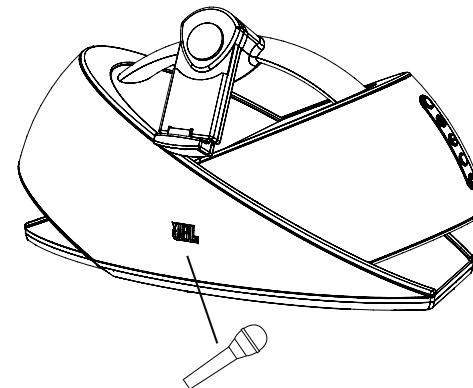

3. When the phone call is finished, press the *Bluetooth* button to end the phone call.

## PLACING A PHONE CALL FROM A BLUETOOTH-ENABLED DEVICE

1. Make sure the JBL OnBeat Xtreme system is paired (see *Bluetooth Pairing*, on page 6).
2. When there is no active call and no incoming call, you can place a call from the JBL OnBeat Xtreme system.
  - To receive a voice prompt for the *Bluetooth* status: Press the *Bluetooth* button on the JBL OnBeat Xtreme unit.
  - To enter voice recognition mode: Press and hold the *Bluetooth* button for two seconds. (If voice recognition is not supported on the device, this action redials the last phone number that was called from the paired phone.)
3. When the phone call is finished, use the appropriate voice command or press the *Bluetooth* button to end the phone call.

## DOCKING AN iPod/iPhone/iPad DEVICE

**NOTE:** When docking an iPod, iPhone or iPad device, you must set the device's "Shake to Shuffle" feature to "Off." Otherwise, the JBL OnBeat Xtreme unit's bass energy can activate the device's shuffle trigger, causing songs to change unexpectedly.

1. To dock an iPod or iPhone, place the device on the 30-pin connector with the device tilted forward.
2. When the device is firmly seated on the connector, push it all the way back into the dock.

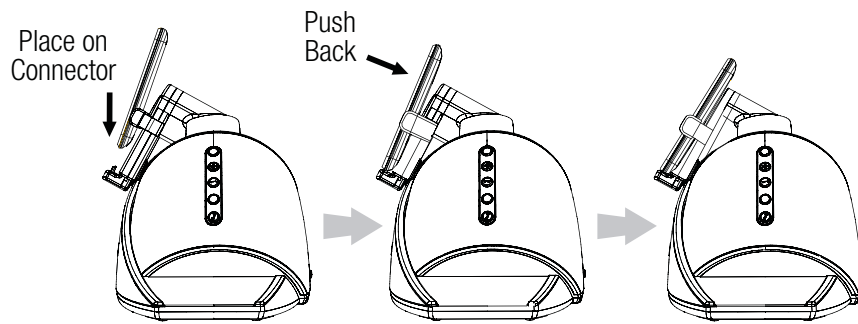

To dock an iPad device, press the lock button on the back of the dock and extend the base of the dock, then follow steps 1 and 2 above.

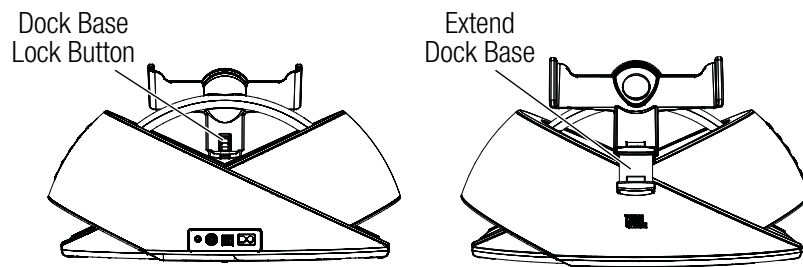

## ROTATING THE DOCK

When an iPod/iPhone/iPad device is docked in the JBL OnBeat Xtreme speaker dock, you can rotate the dock to the landscape mode.

To rotate the dock to the landscape mode, turn it 90 degrees counterclockwise. To rotate it back to the portrait mode, turn it 90 degrees clockwise. The dock will hold the device in place at both the portrait and the landscape positions.

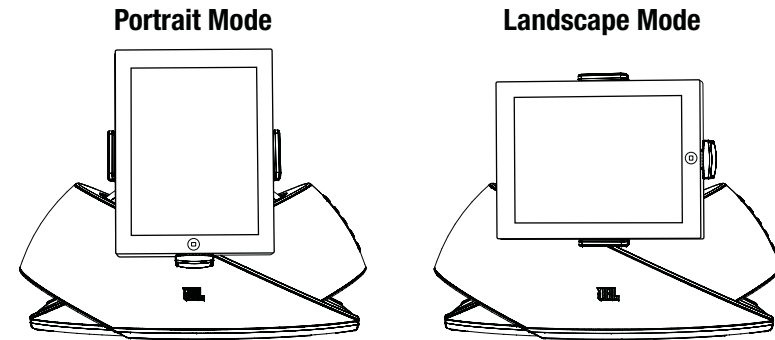

## PLAYING VIDEO AND PHOTO FILES

When you dock your iPod, iPhone or iPad device on the JBL OnBeat Xtreme system, its video output will automatically be set to off, even if it was turned on before you docked the device.

To turn the JBL OnBeat Xtreme system video output on, press the Menu button on the remote control for at least two seconds. The JBL OnBeat Xtreme Source Select LED will flash white once. The video from the iPod, iPhone or iPad device will play on the connected TV. To turn the video output off, press the remote's Menu button again for at least two seconds. The JBL OnBeat Xtreme Source Select LED will flash white twice.



## EQ SETTINGS

The JBL OnBeat Xtreme dock has five equalizer (EQ) modes that adjust the tone quality to suit different types of programs: Music (default), Movies, Internet Radio, Chat, or Games, in that order.

Use the remote control to change the EQ setting for the active source:

1. Press and hold the Enter button on the remote control. The EQ will advance to the next setting (Movies) and the Source Select LED will flash to indicate that the EQ setting has advanced.
2. Each press-and-hold of the Enter button advances the EQ to the next mode: Movies, Internet Radio, Chat, and Games. The Source Select LED will flash each time the EQ advances.
3. When the Source Select LED flashes twice, the EQ has returned to Music mode.

## POWER AND SOURCE SELECT LEDES

The Power LED color changes to indicate the state of JBL OnBeat Xtreme unit.

Power LED Color	State
White – Constant	JBL OnBeat Xtreme unit is on.
White – Flashing	JBL OnBeat Xtreme unit is muted.
Amber – Constant	JBL OnBeat Xtreme unit is in sleep mode.
Amber – Flashing	JBL OnBeat Xtreme unit is in software upgrade mode.*
No LED	JBL OnBeat Xtreme unit is off.

The Source Select LED color changes to indicate which source is active.

Source Select LED Color	State
White – Constant	iPod/iPhone/iPad dock is the active source.
White – Quick Flash Once	EQ for iPod/iPhone/iPad is changed to Movies, Games, Chat, or Internet Radio mode.
White – Quick Flash Twice	EQ for iPod/iPhone/iPad is changed to Music mode.
White – Flash Once	Video is switched on.
White – Flash Twice	Video is switched off.
Blue – Constant	<i>Bluetooth</i> -enabled device is the active source.
Blue – Flashing	<i>Bluetooth</i> -enabled device is in Pairing mode.
Blue – Quick Flash Once	EQ for the <i>Bluetooth</i> -enabled device is changed to Movies, Games, Chat, or Internet Radio mode.
Blue – Quick Flash Twice	EQ for the <i>Bluetooth</i> -enabled device is changed to Music mode.
Amber – Constant	Auxiliary input device is the active source.
Amber – Quick Flash Once	EQ for the auxiliary input device is changed to Movies, Games, Chat, or Internet Radio mode.
Amber – Quick Flash Twice	EQ for the auxiliary input device is changed to Music mode.

\*If the Power LED and the Source Select LED are both flashing amber slowly, the software upgrade failed.

## **SYNCHRONIZING WITH iTunes**

**NOTE:** Before attempting to synchronize your iPod/iPhone/iPad device with iTunes, be sure that both your device and iTunes are updated to the latest software version.

1. Place your iPod/iPhone/iPad device on the JBL OnBeat Xtreme docking connector. Make sure to insert the device all the way onto the connector.
2. Use your computer's iTunes software to synchronize the device with iTunes.
3. When you're finished synchronizing, eject the device from iTunes.

## **CHARGING A DOCKED iPod/iPhone/iPad DEVICE**

The JBL OnBeat Xtreme speaker dock will charge your iPod or iPhone device whenever it is docked.

**NOTE:** The JBL OnBeat Xtreme speaker dock may not charge a docked iPad device via the USB connection to a PC. If the iPad device charges when it is connected directly to the PC via USB, it will charge while docked on the JBL OnBeat Xtreme speaker dock. If the iPad device does not charge when it is connected directly to the PC via USB, it will not charge while docked on the JBL OnBeat Xtreme speaker dock.

## **UPGRADING FIRMWARE**

Your JBL OnBeat Xtreme unit has upgradeable firmware that lets you take advantage of new features and improvements as they become available. Go to [www.jbl.com](http://www.jbl.com) for information about checking your unit's firmware version and instructions on upgrading to a newer firmware version.

## **RESTORING SYSTEM SETTINGS**

You can restore the JBL OnBeat Xtreme unit's factory default settings at any time.

1. Make sure the Power is on. (The Power LED glows white.)
2. Simultaneously press the Power and Source Select buttons.

## **JBL ONBEAT APPLICATION**

The JBL OnBeat application is downloadable free from the iTunes App Store. It features a music browser, an alarm clock and EQ functions that let you select the best sound for your music, movies, gaming, chat or Internet radio.

## TROUBLESHOOTING SOUND QUALITY

Symptom	Possible Problem	Solution	Note
No sound (Power button LED is not illuminated)	Faulty AC connection	Make sure that the JBL OnBeat Xtreme system is connected to a working AC outlet.	The Power button LED glows white when the power is on.
No sound (Power button LED glows amber.)	The JBL OnBeat Xtreme system is in sleep mode.	Press the Power button until it glows white.	
No sound (Power button LED glows white.)	The incorrect source is selected.	Press the Source Select button until the correct source is selected.	The Source Select button glows blue for <i>Bluetooth</i> , white for the iPod/iPhone/iPad dock, and amber for the auxiliary input.
	The volume is set too low.	Press the Volume Up (+) button to increase the volume.	
	The iPod/iPhone/iPad is not docked properly.	Re-attach the iPod/iPhone/iPad to the dock.	You may need to remove the skin from the device before attaching it to the dock.
Sound crackles, hisses or is distorted		<ul style="list-style-type: none"> <li>• Turn down the volume on the iPod/iPhone/iPad or auxiliary device.</li> <li>• Make sure that the EQ setting on the iPod/iPhone/iPad is set to "Off."</li> </ul>	
Loud hum or buzzing		<ul style="list-style-type: none"> <li>• Make sure that the audio cable is plugged all the way into the JBL OnBeat Xtreme's Audio In jack.</li> <li>• Replace the audio cable.</li> <li>• Unplug the power supply and connect it to a different AC outlet.</li> </ul>	
Sound comes from only one speaker		<ul style="list-style-type: none"> <li>• Make sure that the iPod/iPhone/iPad device is properly seated all the way into the docking connector.</li> <li>• Make sure that the audio cable is plugged all the way into the JBL OnBeat Xtreme's Audio In jack.</li> <li>• Make sure the audio cable is a stereo cable.</li> </ul>	

## TROUBLESHOOTING *BLUETOOTH* PAIRING

Symptom	Possible Problem	Solution	Note
The audio device does not pair with the JBL OnBeat Xtreme	The audio device is not compatible with the JBL OnBeat Xtreme unit.	Verify compatibility with manufacturer.	
	The JBL OnBeat Xtreme unit is not powered on.	Press the Power button on the JBL OnBeat Xtreme system.	The Power button glows white when the unit is on.
	The JBL OnBeat Xtreme source is not in <i>Bluetooth</i> mode.	Press the Source Select button until it flashes blue.	The Source Select button flashes blue when it is in pairing mode and glows blue when it is in <i>Bluetooth</i> mode.
	<i>Bluetooth</i> -enabled device's battery is low.	Recharge the device's battery following the instructions in its user manual.	

## SPECIFICATIONS

Compatibility* (Bluetooth):		Input impedance (Aux input):	>15k ohms
Compatibility* (docking):	iPad WiFi + 3G, iPad Wi-Fi®, iPad 2, docking versions of the iPod (including iPod nano 5th generation, iPod touch 2nd generation, iPod nano 4th generation, iPod classic, iPod touch 1st generation, iPod nano 3rd generation, iPod nano 2nd generation, iPod 5th generation, iPhone 4, iPhone 3GS, iPhone 3G, iPhone, MP3 and CD players, desktop and laptop computers (all platforms)	Input connections:	Main connection – iPod and iPhone docking connector; Aux input connection – 3.5mm (1/8") stereo mini jack
Transducers:	Two x JBL Atlas™ woofers and two JBL Ridge tweeters	Power requirement:	100V – 240V AC, 50Hz/60Hz
Amplifier power:	30 watts x 4	Power consumption:	120W (maximum); 40W (operational)
Frequency response:	20Hz – 20kHz	Dimensions (H x D x W):	9" x 9-5/8" x 17-1/2" (230mm x 244mm x 445mm)
Signal-to-noise ratio:	XXdB	Weight:	8.9 lb (4kg)
		*Compatibility at time of writing. For the latest compatibility information, visit <a href="http://www.jbl.com">www.jbl.com</a>	

## FCC notice to users and product statements

This device complies with part 15 of the FCC Rules.

Operation is subject to the following two conditions

- (1) This device may not cause harmful interference, and
- (2) This device must accept any interference received, including interference that may cause undesired operation.

## IC Warning

This device complies with Industry Canada License-exempt RSS standard(s).

Operation is subject to the following two conditions :

- (1) this device may not cause interference, and
- (2) this device must accept any interference, including interference that may cause undesired operation of the device.



 HARMAN Consumer, Inc.  
8500 Balboa Boulevard, Northridge, CA 91329 USA

© 2011 HARMAN International Industries, Incorporated. All rights reserved.

JBL is a trademark of HARMAN International Industries, Incorporated, registered in the United States and/or other countries.

Atlas and OnBeat Xtreme are trademarks of HARMAN International Industries, Incorporated.

The *Bluetooth* word mark and logo are registered trademarks and are owned by the Bluetooth SIG, Inc., and any use of such marks by HARMAN International Industries, Incorporated, is under license.

iPhone, iPod, iPod nano, iPod classic, iTunes, iPod touch and iPad are trademarks of Apple Inc., registered in the U.S. and other countries. iPod/iPhone/iPad not included.

“Made for iPod,” “Made for iPhone” and “Made for iPad” mean that an electronic accessory has been designed to connect specifically to iPod, iPhone and iPad respectively, and has been certified by the developer to meet Apple performance standards. Apple is not responsible for the operation of this device or its compliance with safety and regulatory standards.

Wi-Fi is a registered trademark of the Wi-Fi Alliance.

Features, specifications and appearance are subject to change without notice.

Part No. 950-0344-001

NOTE: This equipment has been tested and found to comply with the limits for a Class B digital device, pursuant to Part 15 of the FCC Rules. These limits are designed to provide reasonable protection against harmful interference in a residential installation.

This equipment generates, uses and can radiate radio frequency energy and, if not installed and used in accordance with the instructions, may cause harmful interference to radio communications.

However, there is no guarantee that interference will not occur in a particular installation.

If this equipment does cause harmful interference to radio or television reception, which can be determined by turning the equipment off and on, the user is encouraged to try to correct the interference by one or more of the following measures:

- Reorient or relocate the receiving antenna.
- Increase the separation between the equipment and receiver.
- Connect the equipment into an outlet on a circuit different from that to which the receiver is connected.
- Consult the dealer or an experienced radio/TV technician for help.

Changes or modifications not expressly approved by the party responsible for compliance could void the user's authority to operate the equipment.

This equipment complies with FCC radiation exposure limits set forth for an uncontrolled environment. This equipment should be installed and operated with minimum 20 cm between the radiator and your body.

This transmitter must not be collocated or operation in conjunction with any other antenna or transmitter unless authorized to do so by the FCC.