



by HARMAN
Harman Consumer, Inc

SB300 CNTR

Powered soundbar



QUICK-START GUIDE

THANK YOU FOR CHOOSING THIS JBL® PRODUCT

The SB300 is a two-piece home theater speaker system that includes a powered stereo soundbar speaker, a wireless 8-inch (200mm), 100-watt powered subwoofer and all of the cables you need to connect the soundbar to your TV and your cable/satellite tuner or DVD player. Both components feature the dynamic new JBL Weave design for a distinctive, one-of-a-kind look.

We're confident that this JBL system will provide every note of enjoyment that you expect – and that when you think about purchasing additional audio equipment for your home, car or office, you will once again choose JBL products.

This quick-start guide contains all the information you need to set up, connect and adjust your new speaker system. For more in-depth information, go to our Web site: www.jbl.com.

INCLUDED ITEMS

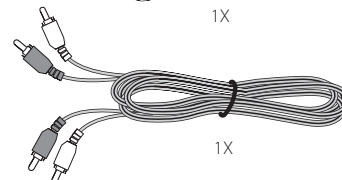
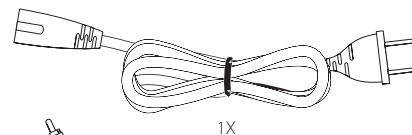
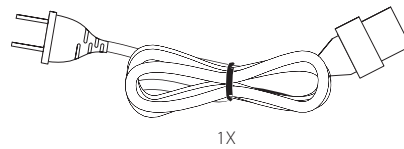
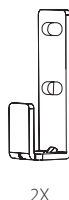
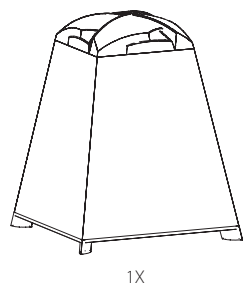
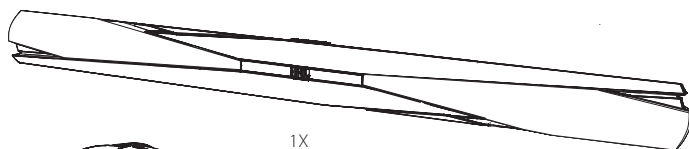

SOUNDBAR REAR-PANEL CONTROLS AND CONNECTIONS

Wireless Pairing Switch: Press this switch to initiate wireless pairing between the soundbar and the wireless subwoofer. See *Pairing the Units for Wireless Operation*, on page 6, for more information

EQ Switch: Use this switch to adjust the soundbar's bass for either wall or table mounting. If you're mounting the soundbar on a wall with the included wall-mount brackets, set the EQ switch to the "Wall" position for the most natural-sounding bass performance. If you are placing the soundbar on a table, set the EQ switch to the "Table" position for the most natural-sounding bass performance.

Aux Input Connection (analog): Use the included stereo audio cable to connect the stereo analog outputs of your TV, DVD player or cable/satellite tuner here.

Optical Connection (digital): If your TV, DVD player or cable/satellite tuner has an optical digital output, connect it here.

NOTE: You can connect different source components to the analog and digital connections.

Power Cord Connector: Connect the included power cord here. See *Power Connections*, on page 5, for more information.

IMPORTANT: Do not connect the power cord to an AC outlet until you have made and verified all other connections.

Power Switch: Set this switch to the "On" position to activate the soundbar. In normal operation, this switch will be left in the "On" position. See *Turning the Soundbar On and Off*, on page 6, for more information.

If you will not be using the soundbar for an extended period – for instance, if you're going on vacation – set the Power switch to the "Off" position.

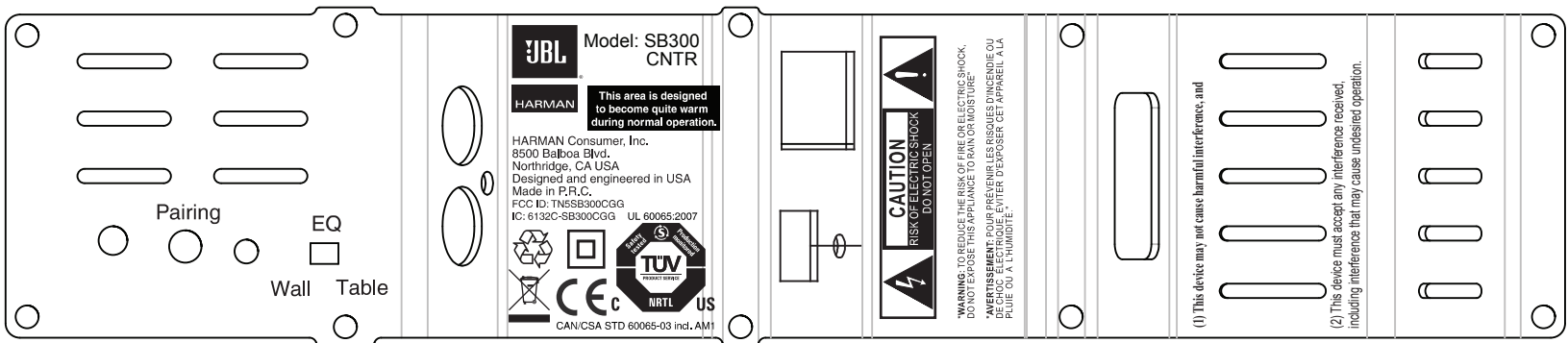

SOUNDBAR TOP-PANEL CONTROLS AND REMOTE CONTROL

Power Button: To turn the system on when the soundbar is in the Standby mode, press the Power button on either the soundbar or the remote. (The Power indicator will turn blue.) To put the system in the Standby mode, press either Power button while the system is on. (The Power indicator will turn amber.) The subwoofer will remain on for approximately one minute after the soundbar goes into the Standby mode. If you do not press the Power button, the soundbar and the subwoofer will both automatically go into the Standby mode approximately 15 minutes after the audio signal ceases.

NOTE: If you put the soundbar into the Standby mode by pressing the Power button, you must manually turn it on by pressing the Power button again. If the system automatically goes into the Standby mode 15 minutes after the audio signal ceases, it will automatically turn on whenever the soundbar detects an audio signal at the input connection that was last used.

Mute Button (remote control only): Press the Mute button to mute the SB300 system. (The Power indicator flashes blue.) While the system is muted, press the Mute button again or the Volume Up button to restore the sound.

NOTE: Momentarily pressing the soundbar's Power button while the system is on will mute the system. Momentarily pressing the button while the system is muted will restore the volume.

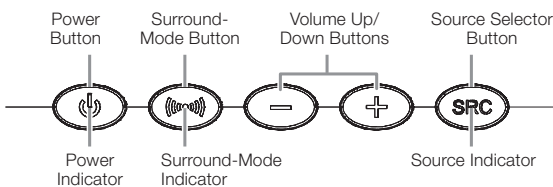

Surround Mode Button: This button turns the SB300 system's 3-D Surround processing on and off. The Surround Mode indicator turns blue when 3-D Surround is active, and turns white when 3-D Surround is not active (normal stereo sound). See *Surround Mode Buttons*, on page 6, for more information. NOTE: The remote control has individual buttons for the Stereo and 3-D Surround modes.

Volume Up/Down Buttons: Press the "+" button to increase the volume; press the "-" button to decrease the volume.

Source Selector Button: This button switches between the sources connected to the Source 1 (analog) and Source 2 (digital) inputs. When Source 1 is active, the Source indicator turns white; when Source 2 is active, the Source indicator turns blue.

NOTE: The remote control has an individual button for each input source.

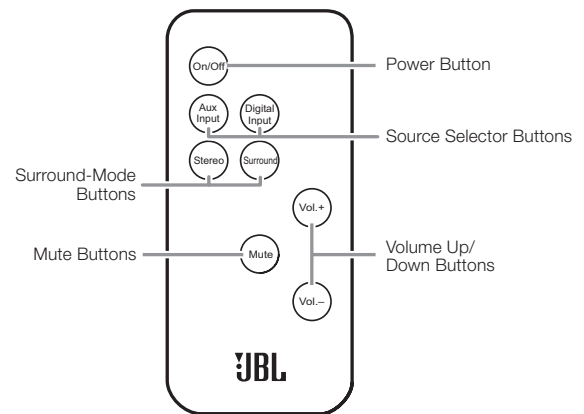

SUBWOOFER REAR-PANEL CONTROLS

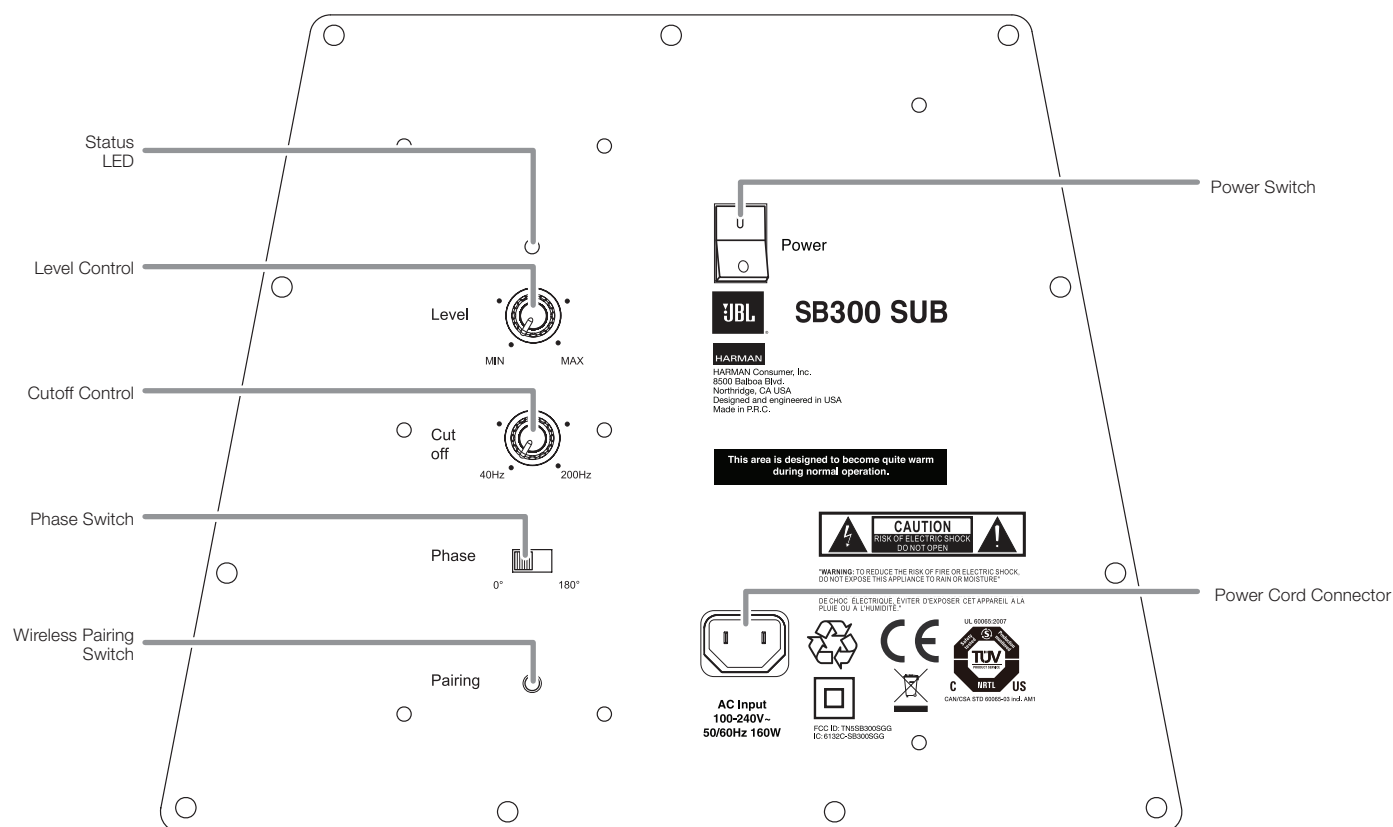

Status LED: Indicates the subwoofer's operational status:

- Lights blue continuously when the subwoofer is on and linked to the soundbar.
- Slowly flashes blue when the subwoofer is on and the wireless link is not established between the subwoofer and the soundbar.
- Rapidly flashes blue during the wireless pairing process.
- Lights amber continuously when the subwoofer is in the Standby mode.
- Turns off when the subwoofer's Power switch is in the "Off" position.

Level Control: Use this control to balance the subwoofer's volume with that of the soundbar. Turn the knob clockwise to increase the subwoofer's volume; turn it counterclockwise to decrease the subwoofer's volume.

Cutoff Control: This knob adjusts the subwoofer's cutoff between 40Hz and 200Hz. The higher you set the Cutoff control, the higher in frequency the subwoofer will operate and the more its bass will "overlap" that of the soundbar. This adjustment helps achieve a smooth transition of bass frequencies between the subwoofer and the soundbar for a variety of different rooms and subwoofer locations. See *Subwoofer Cutoff Control*, on page 7, for more information.

Phase Switch: This switch determines whether the subwoofer driver's piston-like action moves in and out in phase with the speakers in the soundbar. If the subwoofer were to play out of phase with the soundbar speakers, some of the sound waves produced by the subwoofer or soundbar could be canceled, reducing bass performance and sonic impact. This phenomenon depends in part on the relative placement of the speakers in the room. See *Subwoofer Phase Switch*, on page 7, for more information.

Wireless Pairing Switch: Press this switch to initiate wireless pairing between the subwoofer and the soundbar. See *Pairing the Units for Wireless Operation*, on page 6, for more information.

Power Switch: Set this switch to the "On" position to activate the subwoofer. In normal operation, this switch will be left in the "On" position. See *Turning the Subwoofer On and Off*, on page 6, for more information.

If you will not be using the subwoofer for an extended period – for instance, if you're going on vacation – set the Power switch to the "Off" position.

Power Cord Connector: Connect the included power cord here and into an active, unswitched AC outlet. See *Power Connections*, on page 5, for more information.

IMPORTANT: Do not connect the power cord to an AC outlet until you have made and verified all other connections.

SPEAKER PLACEMENT

PLACING THE SOUNDBAR ON A TABLE

If your TV is placed on a table, you can place the soundbar on the table directly in front of the TV stand, centered with the TV screen. As long as the surface of the table is flat, the soundbar will rest on its rubber bumpers.

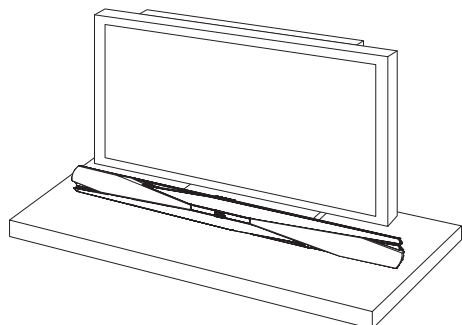

WALL-MOUNTING THE SOUNDBAR

If your TV is attached to a wall, you can use the included wall-mount brackets to mount the soundbar on the wall directly below the TV screen.

1. Determine the location for the soundbar on the wall. Make sure that the top of the soundbar will not block your view of the TV screen when it is mounted on the wall.
2. Mark the locations of the soundbar wall-mount bracket holes on the wall. The holes for the left and right brackets are spaced 30-5/16" (770mm) apart, and are designed to accept 4mm diameter screws. The top and bottom holes for each bracket are spaced 1" (25mm) apart. See the illustration below.



NOTE: To ensure that the soundbar will be level, use a carpenter's level, laser sight or other device to ensure that the two sets of holes are at exactly the same height.

3. Attach the two wall-mount brackets to the wall at the locations you marked, using hardware that is appropriate for the wall's construction and materials. Note that the soundbar weighs 2.5kg (5.5 lb). Be sure to use hardware that can support this weight.



4. After making all of the connections described in the *Connections* section, on page 5, attach the soundbar to the brackets by sliding the brackets' vertical tabs into the slots in the soundbar's rubber bumpers.

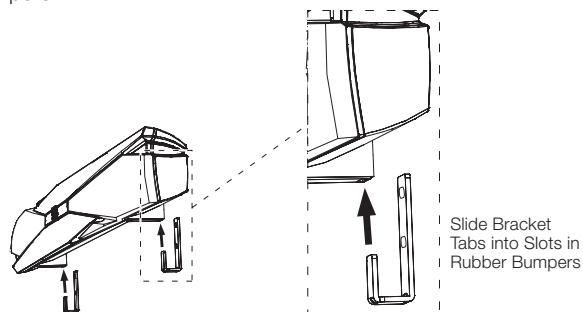

PLACING THE SUBWOOFER

The performance of a subwoofer is directly related to its placement in the listening room and its physical position relative to the other speakers in the system.

While it is true that in general, our ears do not hear directional sounds at the low frequencies where subwoofers operate, when installing a subwoofer within the limited confines of a room, the reflections, standing waves and absorptions generated within the room will strongly influence the performance of any subwoofer system. As a result, the specific location of the subwoofer in the room does become important to the amount and quality of bass that is produced.

For example, placing the subwoofer next to a wall generally will increase the amount of bass in the room; placing it in a corner (1) generally will maximize amount of bass in the room. However, corner placement can also increase the destructive effect of standing waves on bass performance. This effect can vary depending on the listening position – some listening positions may yield very good results, while others may have far too much (or too little) bass at certain frequencies.

In many rooms, placing the subwoofer along the same plane as the soundbar (2) can produce the best integration between the sound of the subwoofer and that of the left and right speakers. In some rooms, the best performance could even result from placing the subwoofer behind the listening position (3).

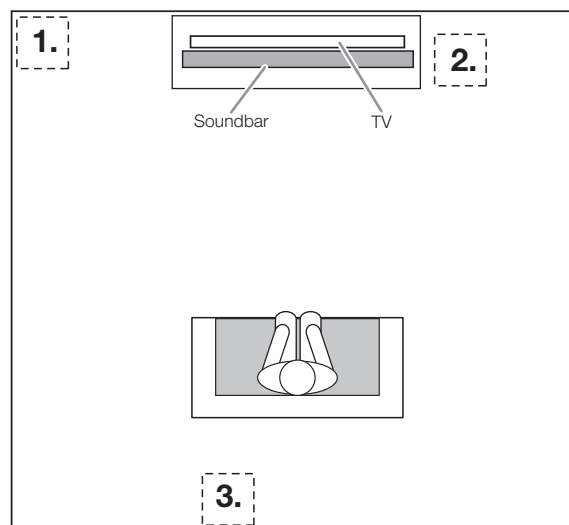

We strongly recommend that you experiment with placement before choosing a final location for your subwoofer. One way you can determine the best location for the subwoofer is by temporarily placing it in the listening position and playing music with strong bass content. Move around to various locations in the room while the system is playing (putting your ears where the subwoofer would be placed), and listen until you find the location where the bass performance is best. Place the subwoofer in that location.

IMPORTANT: The maximum wireless operating distance between the soundbar and subwoofer is approximately 50 feet (15.3m).

CONNECTIONS

SOURCE CONNECTIONS

Analog: Use the supplied stereo audio cable to connect the soundbar's Source 1 (analog) input to your TV's stereo audio output. If your TV has two sets of audio output jacks, use the set that has a fixed (not variable) output level. This will let you turn your TV's speakers all the way off while the TV still supplies a constant audio signal to the soundbar.

Digital: If your DVD player, cable tuner or satellite tuner has an optical digital output, you can use an optical digital audio cable to connect it to the soundbar's Source 2 (optical digital) input.

NOTE: If your DVD player, cable tuner or satellite tuner does not have an optical digital output, you can connect its analog audio output to your TV. The TV will send its audio signal to the soundbar through the analog connection described above.

POWER CONNECTIONS

After verifying that all of the source connections have been made properly, plug the supplied power cords into the soundbar's and subwoofer's Power Cord connectors, and plug the other ends into active, unswitched AC outlets. Do NOT plug these cords into the accessory outlets found on some audio components.

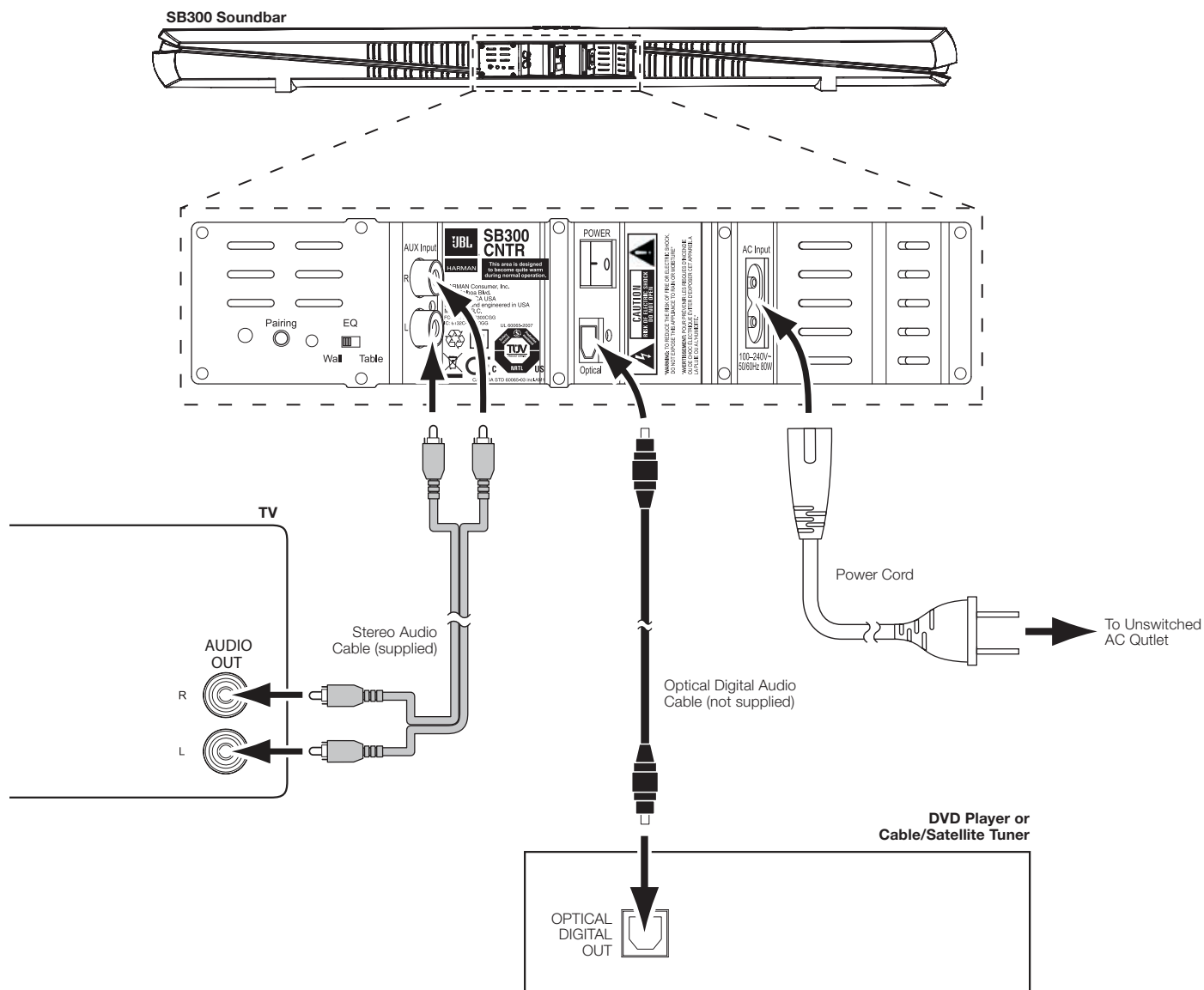

USING YOUR SOUNDBAR SYSTEM

TURNING THE SOUNDBAR ON AND OFF

Set the soundbar's Power switch to the "On" position.

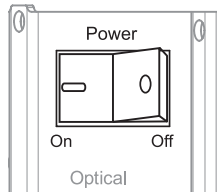

Press the Power button on either the soundbar or the remote to turn the soundbar on. To put the soundbar in the Standby mode, press either Power button while the soundbar is on.



If you do not press the Power button, the soundbar will automatically go into the Standby mode approximately 15 minutes after the audio signal ceases. NOTE: If you have put the soundbar into the Standby mode by pressing the Power button, you must manually turn it on by pressing the Power button again. If the soundbar has automatically gone into the Standby mode 15 minutes after the audio signal has ceased, it will automatically turn itself on when it receives an audio signal at either the analog (Aux) input or the optical digital input.

TURNING THE SUBWOOFER ON AND OFF

Set the subwoofer's Power switch to the "On" position. The subwoofer will automatically attempt to establish pairing with the soundbar (the subwoofer's LED will flash blue). If pairing is not established within one minute, the subwoofer will enter the Standby mode (its LED will turn amber). If pairing is established, the subwoofer will turn on (its LED will light blue continuously).

The subwoofer will remain on for approximately one minute after the soundbar enters the Standby mode, or for approximately 15 minutes after the audio signal ceases.

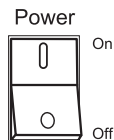

If you will be away from home for an extended period of time, or if you will not be using the system for an extended period, set the subwoofer's Power switch to the "Off" position.

PAIRING THE UNITS FOR WIRELESS OPERATION

After turning the soundbar and subwoofer on for the first time, you will need to "pair" the subwoofer and soundbar so they both operate at the same wireless frequency. To pair the units, press the Wireless Pairing switches on both units within 30 seconds. The units will communicate with each other and operate at the same frequency.

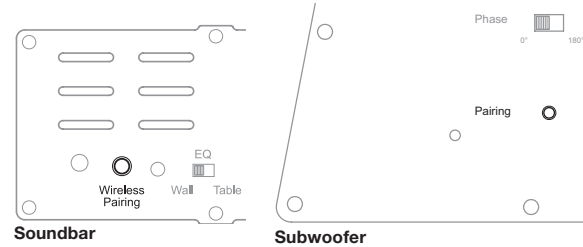

NOTE: The maximum wireless operating distance between the soundbar and subwoofer is approximately 50 feet (15.3m).

ADJUSTING THE SYSTEM'S VOLUME

Press the soundbar's or remote's Volume Up and Down buttons to raise and lower the system's volume one step at a time. Hold down the buttons to continuously raise or lower the volume.



For the best sound, we recommend turning your TV's built-in speakers off. Consult your TV's owner's manual to find out how to do this.

MUTING THE SYSTEM

Momentarily press the soundbar's Power button or press the remote's Mute button to mute the system. (The Power Indicator flashes blue.) Momentarily press the soundbar's Power button or press the remote's Mute button again to un-mute the system. (The Power Indicator turns to a steady blue.)



SURROUND MODE BUTTONS

These buttons switch the sound between normal stereo (the Surround Mode Indicator lights white) and 3-D Surround (the Surround Mode Indicator lights blue). The 3-D Surround setting will produce a complete surround-sound experience for anyone sitting in front of and several feet away from the soundbar. Although it is particularly effective when watching movies, you can also try the 3-D Surround setting for music.

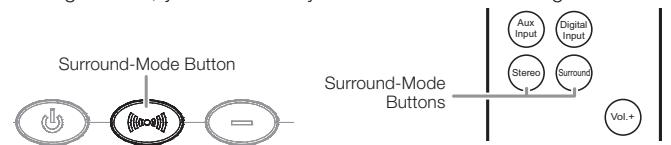

SUBWOOFER LEVEL KNOB

Use the subwoofer's Level knob to balance the bass with the rest of the sound. Play music or movies that you are familiar with, and adjust the subwoofer's Level knob so the bass sounds balanced on both music and films. Listen to several different music recordings and film soundtracks that contain strong bass passages, and find a setting for the Level knob that doesn't over-emphasize the bass or make it sound weak.

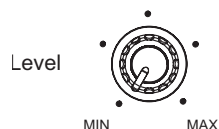

Once you find a setting for the subwoofer's Volume knob that balances the bass with the rest of the sound, you shouldn't have to change it.

SUBWOOFER CUTOFF CONTROL

The subwoofer's Cutoff control adjusts the subwoofer's cutoff between 40Hz and 200Hz. The higher you set the Cutoff control, the higher in frequency the subwoofer will operate and the more its bass will "overlap" that of the soundbar. This adjustment helps achieve a smooth transition of bass frequencies between the subwoofer and the soundbar for a variety of different rooms and subwoofer locations.



To set the Cutoff control, listen for the smoothness of the bass. If the bass seems too strong at certain frequencies, try a lower Cutoff control setting. If the bass seems too weak at certain frequencies, try a higher Cutoff control setting.

SUBWOOFER PHASE SWITCH

This switch determines whether the subwoofer's piston-like action moves in and out in phase with the speakers in the soundbar. If the subwoofer were to play out of phase with the soundbar speakers, some of the sound waves produced by the soundbar and subwoofer could be canceled out at some frequencies, reducing bass performance and sonic impact. This phenomenon depends in part on the relative placement of the soundbar and subwoofer in the room.



Although there is no absolutely correct setting for the Phase switch, in most cases it should be left in the "0°" position. When the subwoofer is properly in phase with the soundbar speakers, the sound will be clearer and have more impact. It will make percussive sounds like drums, piano and plucked strings sound more lifelike. The best way to set the Phase switch is to listen to music that you are familiar with and adjust the switch so that drums and other percussive sounds have maximum impact.

SPECIFICATIONS

SB300 SYSTEM

Frequency response:	42Hz – 20kHz (–3dB)
---------------------	---------------------

SB300 POWERED SOUNDBAR SPEAKER

Low-frequency transducer:	Two 2" (51mm) cones per channel, video-shielded
---------------------------	-------------------------------------------------

High-frequency transducer:	One 1" (25mm) dome per channel, video-shielded
----------------------------	------------------------------------------------

Amplifier power:	30 watts per channel
------------------	----------------------

Audio controls:	Volume, surround mode
-----------------	-----------------------

Connections:	Optical digital (TOSLINK™) input, stereo analog (RCA-type) inputs
--------------	-------------------------------------------------------------------

Power requirement:	100V – 240V, 50Hz/60Hz, 80W
--------------------	-----------------------------

Power consumption:	1W standby; 80W maximum
--------------------	-------------------------

Dimensions (H x W x D):	3-5/8" x 45-3/4" x 3" (92mm x 1162mm x 76mm)
-------------------------	-------------------------------------------------

Weight:	5.5 lb (2.5kg)
---------	----------------

SB300SUB SUBWOOFER

Low-frequency transducer:	8" (200mm) cone, down-firing
---------------------------	------------------------------

Enclosure type:	Ported (down-firing)
-----------------	----------------------

Amplifier power:	100 watts
------------------	-----------

Frequency response:	42Hz – 200Hz (–3dB)
---------------------	---------------------

Audio controls:	Level, phase, cutoff frequency
-----------------	--------------------------------

Connections:	LFE input, left and right RCA line-level inputs
--------------	-------------------------------------------------

Power requirement:	100V – 240V, 50Hz/60Hz, 160W
--------------------	------------------------------

Power consumption:	1W standby; 160W maximum
--------------------	--------------------------

Dimensions (H x W x D):	19" x 14-1/4" x 14-1/4" (483mm x 362mm x 362mm)
-------------------------	----------------------------------------------------

Weight:	24.5 lb (11.1kg)
---------	------------------

IMPORTANT SAFETY INSTRUCTIONS

FOR ALL PRODUCTS:

1. Read these instructions.
2. Keep these instructions.
3. Heed all warnings.
4. Follow all instructions.
5. Do not use this apparatus near water.
6. Clean only with a dry cloth.
7. Do not block any ventilation openings. Install this apparatus in accordance with the manufacturer's instructions.
8. Do not install this apparatus near any heat sources such as radiators, heat registers, stoves or other apparatus (including amplifiers) that produce heat.
9. Do not defeat the safety purpose of the polarized or grounding-type plug. A polarized plug has two blades with one wider than the other. A grounding-type plug has two blades and a third grounding prong. The wide blade or the third prong is provided for your safety. If the provided plug does not fit into your outlet, consult an electrician for replacement of the obsolete outlet.
10. Protect the power cord from being walked on or pinched, particularly at plugs, convenience receptacles and the point where they exit from the apparatus.
11. Use only attachments/accessories specified by the manufacturer.
12. Use only with the cart, stand, tripod, bracket or table specified by the manufacturer or sold with the apparatus. When a cart is used, use caution when moving the cart/apparatus combination to avoid injury from tip-over. 
13. Unplug this apparatus during lightning storms or when unused for long periods of time.
14. Refer all servicing to qualified service personnel. Servicing is required when the apparatus has been damaged in any way, such as when the power-supply cord or plug is damaged, liquid has been spilled or objects have fallen into the apparatus, or the apparatus has been exposed to rain or moisture, does not operate normally or has been dropped.
15. Do not expose this apparatus to dripping or splashing, and ensure that no objects filled with liquids, such as vases, are placed on the apparatus.
16. To disconnect this apparatus from the AC mains completely, disconnect the power-supply cord plug from the AC receptacle.
17. The mains plug of the power-supply cord shall remain readily operable.
18. Do not expose batteries to excessive heat such as sunshine, fire or the like.

CAUTION

RISK OF ELECTRIC SHOCK. DO NOT OPEN.



THE LIGHTNING FLASH WITH AN ARROWHEAD SYMBOL, WITHIN AN EQUILATERAL TRIANGLE, IS INTENDED TO ALERT THE USER TO THE PRESENCE OF UNINSULATED DANGEROUS VOLTAGE WITHIN THE PRODUCT'S ENCLOSURE THAT MAY BE OF SUFFICIENT MAGNITUDE TO CONSTITUTE A RISK OF ELECTRIC SHOCK TO PERSONS.



THE EXCLAMATION POINT WITHIN AN EQUILATERAL TRIANGLE IS INTENDED TO ALERT THE USER TO THE PRESENCE OF IMPORTANT OPERATING AND MAINTENANCE (SERVICING) INSTRUCTIONS IN THE LITERATURE ACCOMPANYING THE PRODUCT.

WARNING: TO REDUCE THE RISK OF FIRE OR ELECTRIC SHOCK, DO NOT EXPOSE THIS APPARATUS TO RAIN OR MOISTURE.

FOR PRODUCTS THAT TRANSMIT AND RECEIVE RF ENERGY:

FCC REGULATIONS (USA ONLY)

FCC INFORMATION FOR USERS

This device complies with Part 15 of the FCC rules. Operation is subject to the following two conditions: (1) This device may not cause harmful interference; and (2) this device must accept any interference received, including interference that may cause undesired operation.

RADIO AND TELEVISION INTERFERENCE

This equipment has been tested and found to comply with the limits for a Class B digital device, pursuant to Part 15 of the FCC rules. These limits are designed to provide reasonable protection against harmful interference in a residential installation. This equipment generates, uses and can radiate radio-frequency energy and, if not installed and used in accordance with the instructions, may cause harmful interference to radio communications. However, there is no guarantee that interference will not occur in a particular installation. If this

equipment does cause interference to radio or television reception, which can be determined by turning the equipment off and then on, the user is encouraged to try to correct the interference by one or more of the following measures:

- Increase the separation between the equipment and the receiver.
- Connect the equipment to a different outlet so that the equipment and receiver are on different branch circuits.
- Consult the dealer or an experienced radio/TV technician for help.

NOTE: Changes or modifications not expressly approved by HARMAN could void the user's authority to operate the equipment.

IC STATEMENT AND WARNING (CANADA ONLY)

This Class B digital apparatus complies with Canadian ICES-003. Cet appareil numérique de la classe B est conforme à la norme NMB-003 du Canada.

FOR CANADIAN MODEL

This Class B digital apparatus complies with Canadian ICES-003.

MODÈLE POUR LES CANADIEN

Cet appareil numérique de la classe B est conforme à la norme NMB-003 du Canada.

FOR PRODUCTS WITH RADIO RECEIVERS THAT CAN USE AN EXTERNAL ANTENNA:

CATV (CABLE TV) OR ANTENNA GROUNDING

If an outside antenna or cable system is connected to this product, be certain that it is grounded so as to provide some protection against voltage surges and static charges. Section 810 of the National Electrical Code (NEC), ANSI/NFPA No. 70-1984, provides information with respect to proper grounding of the mast and supporting structure, grounding of the lead-in wire to an antenna discharge unit, size of grounding conductors, location of antenna discharge unit, connection to grounding electrodes and requirements of the grounding electrode.

IMPORTANT SAFETY INSTRUCTIONS

NOTE TO CATV SYSTEM INSTALLER:

This reminder is provided to call the CATV (cable TV) system installer's attention to article 820-40 of the NEC, which provides guidelines for proper grounding and, in particular, specifies that the cable ground shall be connected to the grounding system of the building, as close to the point of cable entry as possible.

FOR CD/DVD/Blu-ray Disc™ PLAYERS:

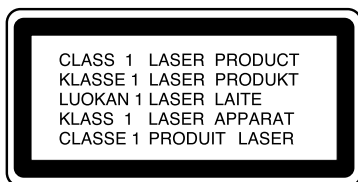

CAUTION:

This product uses a laser system. To prevent direct exposure to the laser beam, do not open the cabinet enclosure or defeat any of the safety mechanisms provided for your protection. DO NOT STARE INTO THE LASER BEAM. To ensure proper use of this product, please read

Canada Statement

This Device complies with RSS-210 of the IC Rules; Operation is subject to the following two conditions:

- (1). This device may not cause interference and
- (2). This device must accept any interference received, including interference that may cause undesired operation.

Le présent appareil est conforme aux CNR d'Industrie Canada applicables aux appareils radio exempts de licence.

L'exploitation est autorisée aux deux conditions suivantes : (1) l'appareil ne doit pas produire de brouillage, et

- (2) l'utilisateur de l'appareil doit accepter tout brouillage radioélectrique subi, même si le brouillage est susceptible d'en compromettre le fonctionnement.

the owner's manual carefully and retain it for future use. Should the unit require maintenance or repair, please contact your local JBL service center. Refer servicing to qualified personnel only.

FOR PRODUCTS THAT INCLUDE BATTERIES:



INSTRUCTIONS FOR USERS ON REMOVAL AND DISPOSAL OF USED BATTERIES

CAUTION

RISK OF EXPLOSION IF BATTERY IS INCORRECTLY REPLACED. REPLACE ONLY WITH THE SAME OR EQUIVALENT TYPE.

Alkaline batteries are considered nonhazardous. Rechargeable batteries (i.e., nickel-cadmium, nickel-metal-hydride, lithium and lithium-ion) are considered hazardous household materials and may pose an unnecessary health and safety risk.

In the European Union and other locations, it is illegal to dispose of any battery with household trash. All batteries must be disposed of in an environmentally sound manner. Contact your local waste-management officials for information regarding the environmentally sound collection, recycling and disposal of used batteries.

To remove the batteries from your equipment or remote control, reverse the procedure described in the owner's manual for inserting batteries.

For products with a built-in battery that lasts for the lifetime of the product, removal may not be possible for the user. In this case, recycling or recovery centers handle the dismantling of the product and the removal of the battery. If, for any reason, it becomes necessary to replace such a battery, this procedure must be performed by authorized service centers.

FCC Radiation Exposure Statement

This equipment complies with FCC RF radiation exposure limits set forth for an uncontrolled environment. This transmitter must not be co-located or operating in conjunction with any other antenna or transmitter. This equipment should be installed and operated with a minimum distance of 20 centimeters between the radiator and your body.



HARMAN Consumer, Inc.
8500 Balboa Boulevard, Northridge, CA 91329 USA
516.255.4545 (USA only)

© 2010 HARMAN International Industries, Incorporated. All rights reserved.

JBL is a trademark of HARMAN International Industries, Incorporated, registered in the United States and/or other countries.

Blu-ray Disc is a trademark of the Blu-ray Disc Association. Features, specifications and appearance are subject to change without notice.

www.jbl.com



HARMAN Consumer, Inc.
8500 Balboa Boulevard, Northridge, CA 91329 USA

© 2010 HARMAN International Industries, Incorporated. All rights reserved.
JBL is a trademark of HARMAN International Industries, Incorporated, registered in the United States and/or other countries.
TOSLINK is a trademark of Toshiba Corporation.

Features, specifications and appearance are subject to change without notice.

Part No. 819016501400S

www.jbl.com