

AVR 1710, AVR 171-230, AVR 171-230C,
AVR 1610, AVR 161-230, AVR 161-230C,
AVR 1510, AVR 151-230, AVR 151-230C

Audio/Video Receiver

Quick-Start Guide



harman/kardon
by HARMAN

Introduction

Thank you for choosing a Harman Kardon product!

This quick-start guide contains all the information you need to connect and set up your new Harman Kardon audio/video receiver (AVR).

To conserve our natural resources, your AVR does not include a printed owner's manual. An owner's manual containing complete information about operating all of your new AVR's features is available at our Web site. Go to www.harmankardon.com and download the *AVR 1710/AVR 171-230/AVR171-230C/AVR 1610/AVR 161-230/AVR 161-230C Owner's Manual* or the *AVR 1510/AVR 151-230/AVR 151-230C Owner's Manual*.

Place the AVR

- Place the AVR on a firm and level surface. Be certain that the surface and any mounting hardware can support the AVR's weight.
- Provide proper space above, below, behind and to the sides of the AVR for ventilation. Maintain a clearance of at least 12" (30cm) on each side of, above and behind the unit.
- If you install the AVR in a cabinet or other enclosed area, provide cooling air within the cabinet. Under some circumstances, a fan may be required.
- Do not obstruct the ventilation slots on the top of the AVR or place objects directly over them.
- Do not place the AVR directly on a carpeted surface.
- Do not place the AVR in moist or humid locations, in extremely hot or cold locations, in areas near heaters or heat registers, or in direct sunlight.

Connections

CAUTION: Before making any connections to the AVR, ensure that the AVR's AC cord is unplugged from the AVR and the AC outlet. Making connections with the AVR plugged in and turned on could damage the speakers.

Place Your Speakers

Determine the locations for your system's speakers according to their manufacturer's directions and the layout of your listening room. Use the illustrations below as a guide for 7.1-channel and 5.1-channel systems.

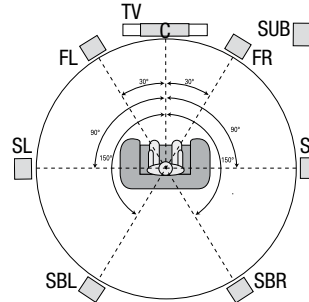

Speaker Positioning for 7.1-Channel Systems

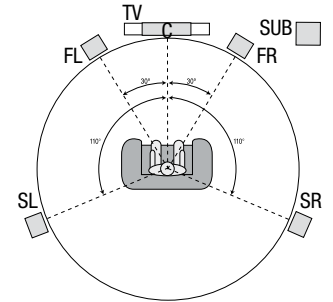

Speaker Positioning for 5.1-Channel Systems

For more detailed speaker placement information, including the use of front height speakers with the Dolby Pro Logic IIz mode, download the complete *AVR 1710/AVR 171-230/AVR171-230C/AVR 1610/AVR 161-230/AVR 161-230C Owner's Manual* or the *AVR 1510/AVR 151-230/AVR 151-230C Owner's Manual*, from www.harmankardon.com.

AVR 1710/AVR 171

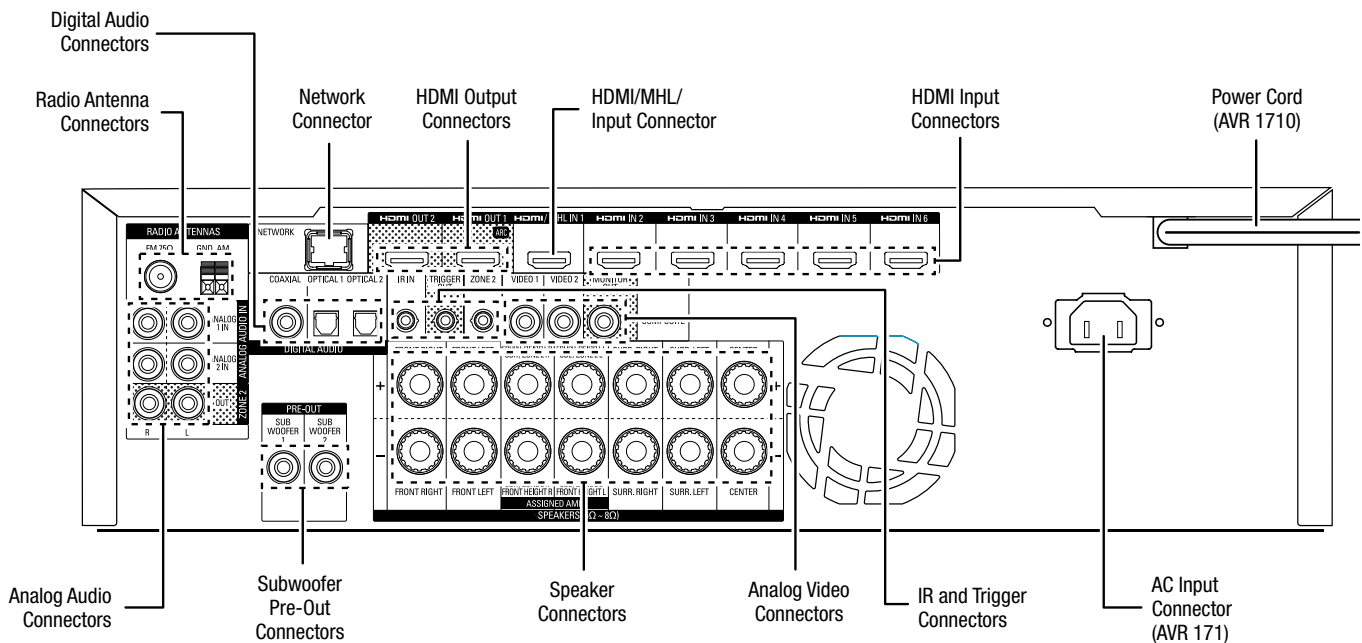

AVR 1610/AVR 161

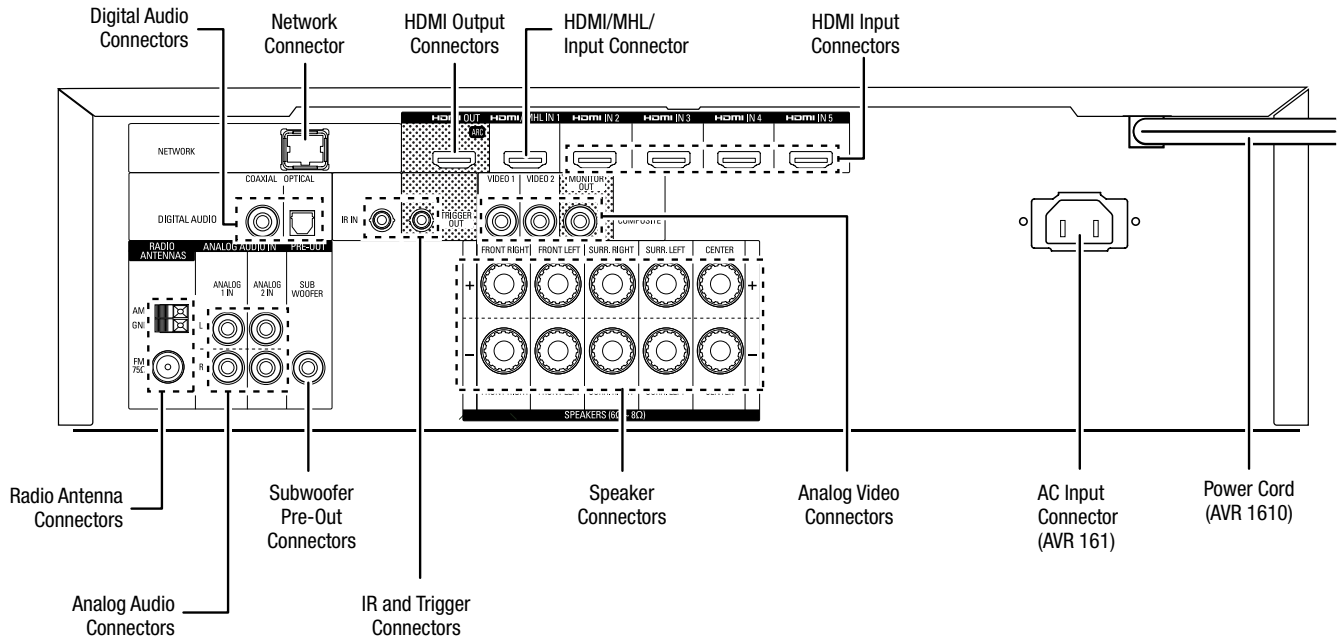

AVR 1510/AVR 151

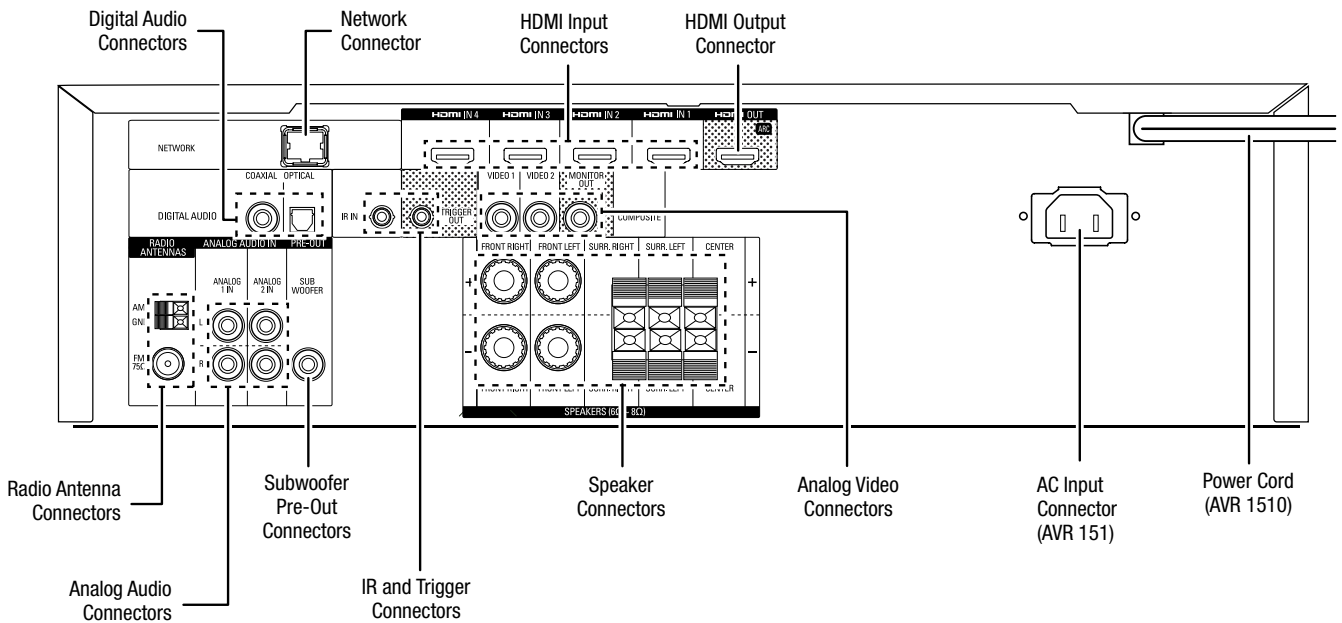

Connect Your Speakers

How to use the AVR speaker terminals:

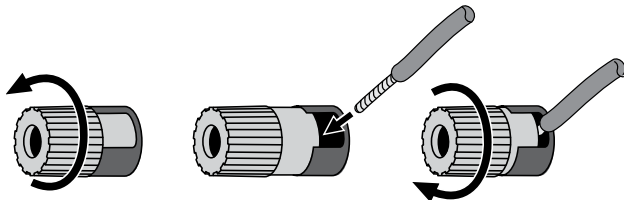

1. Unscrew Cap
2. Insert Bare Wire
3. Tighten Cap

Always connect the colored (+) terminal on the AVR to the (+) terminal on the speaker (usually red), and the black (-) terminal on the AVR to the (-) terminal on the speaker (usually black).

IMPORTANT: Make sure the (+) and (-) bare wires do not touch each other or the other terminal. Touching wires can cause a short circuit that can damage your AVR.

Connect the speakers as shown in the illustration.

AVR 1710/AVR 171 Only:
Connect Surround Back L/R Speakers
-OR- Front Height L/R Speakers Here

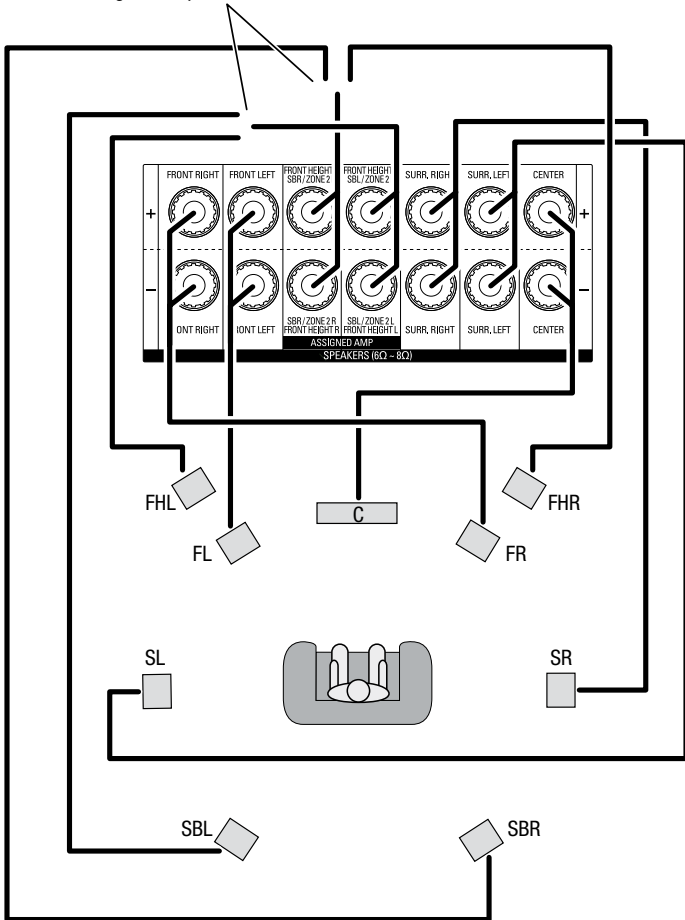

Connect Your Subwoofer

Use a single RCA audio cable to connect your subwoofer to AVR's Sub Woofer Pre-Out connector, as shown in the illustration at the top of the next column. (For the AVR 1710/AVR 171-230/AVR 171-230C you can use either the Sub Woofer 1 or Sub Woofer 2 connector when you're using a single subwoofer, or you may connect two subwoofers for increased bass performance in larger listening rooms.) Consult your subwoofer's user manual for specific information about making connections to it.

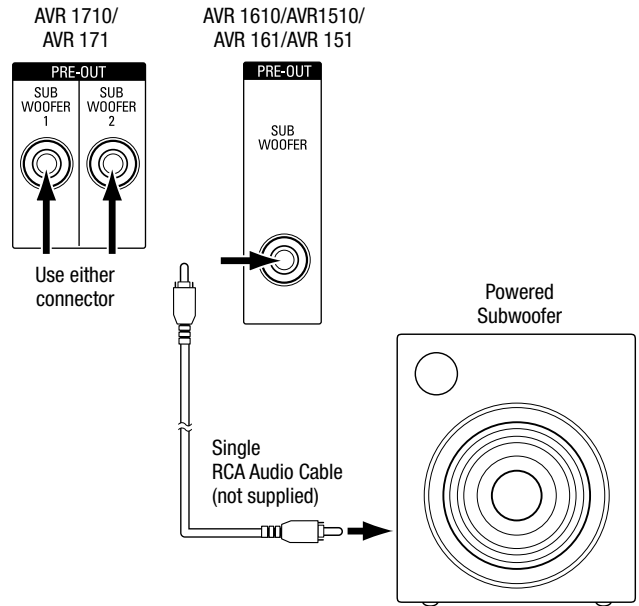

Connect Your TV or Video Display

If your TV has an HDMI connector: Use an HDMI cable (not included) to connect it to the AVR's HDMI Out connector. (For the AVR 1710/AVR 171 you can use either HDMI Out connector.) You do not need to make any other connections to your TV from the AVR or from any of your video source components.

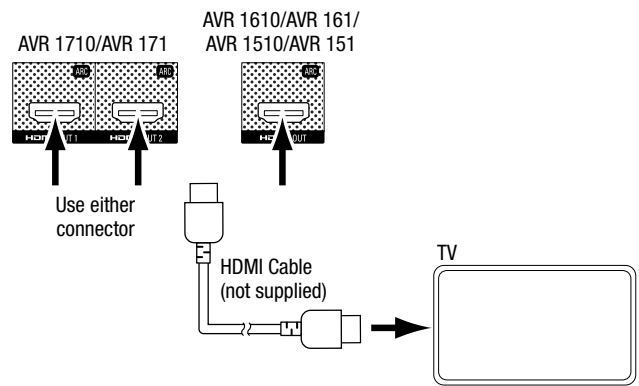

AVR 1710/AVR 171 only: Connect a single TV to either of the HDMI Out connectors. If you have a second TV you can connect it to the AVR's HDMI Out 2 connector. Both TVs will display the same picture.

Note: If your TV is equipped with the HDMI Audio Return Channel Function, you can feed its sound to the AVR via the HDMI Out connection's Audio Return Channel, and it will not require additional audio connections to the AVR. Refer to the complete *Assign the HDMI Audio Return Channel*, on page 9.

If your TV does not have an HDMI connector: Use a composite video cable (not included) to connect the AVR's Composite Monitor Out connector to your TV's composite video connector.

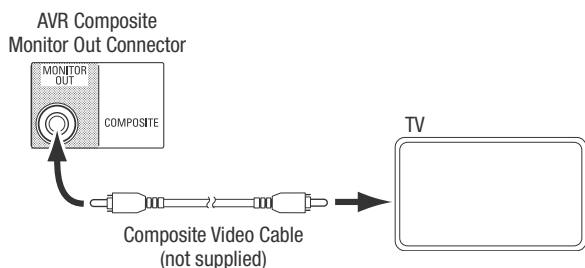

Note: The HDMI connection to your TV is preferred. If you use the composite video connection to your TV, you will not be able to view the AVR's on-screen menus and will need to use the AVR's front-panel display to set up the AVR.

Connect Your Audio and Video Source Devices

Source devices are components where a playback signal originates, e.g. a Blu-ray Disc™ or DVD player; a cable, satellite or HDTV tuner; etc. Your AVR has several different types of input connectors for your audio and video source devices: HDMI, composite video, optical digital audio, coaxial digital audio and analog audio. The connectors are not labeled for specific types of source devices; they are labeled numerically, so you can connect your devices according to your individual system's make-up.

Your AVR's various source buttons have default assignments to different input connectors (listed in the "Default Connector(s)" column of the table below). For ease of setup, you should connect each source device to the connector where the corresponding default source button is assigned (e.g., connect your Blu-ray Disc player to HDMI 2).

However, you can connect your source devices as you wish and re-assign any of the input connections to any of the Source Buttons listed in the table according to where you actually connect each of your source devices.

As you connect your various source devices, fill out the "Connected Device" column in the table – it will make it easier for you to assign the various source buttons after you have completed making all of the connections. (You will make any changes to the source-button assignments and fill in the "Assigned Connector(s)" column later in the setup process.)

Note: You cannot assign connectors to the Network, Radio, TV and USB source buttons.

Source Button	Default Connector(s)	Assigned Connector(s)	Connected Device
MHL (AVR 1710/AVR 171/AVR 1610/AVR 161); Server (AVR 1510/AVR 151)	HDMI 1		
Disc	HDMI 2		
Cable/Sat	HDMI 3		
STB	HDMI 4		
Game	HDMI 5 (AVR 1710/AVR 171/AVR 1610/AVR 161); Composite 2/Analog 2 (AVR 1510/AVR 151)		
Aux	Composite 1/Analog 1		
Audio	None/Analog 2		
Monitor Output Connector			Connected Device
HDMI Out 1			
HDMI Out 2 (AVR 1710/AVR 171 only)			
Composite Video Monitor Out			

Source Buttons and Assigned Connectors

ROKU Streaming Stick (AVR 1710/AVR 171/AVR 1610/AVR 161 only):

If you have a Roku Streaming Stick, insert it into the AVR's HDMI/MHL In connector.
NOTE: Do not insert the Streaming Stick into any other HDMI In connector.

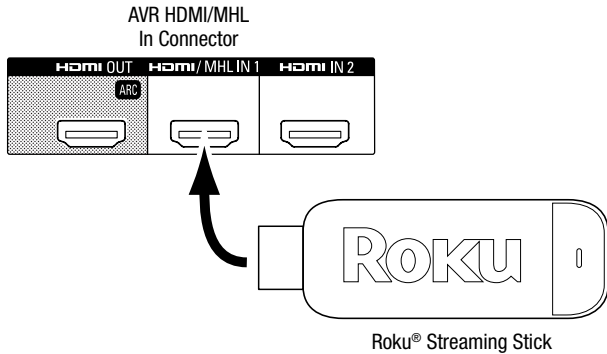

HDMI Devices

If any of your source devices have HDMI connectors, using them will provide the best possible video and audio performance quality. Since the HDMI cable carries both digital video and digital audio signals, you do not have to make any additional audio connections for source devices you connect via HDMI connectors.

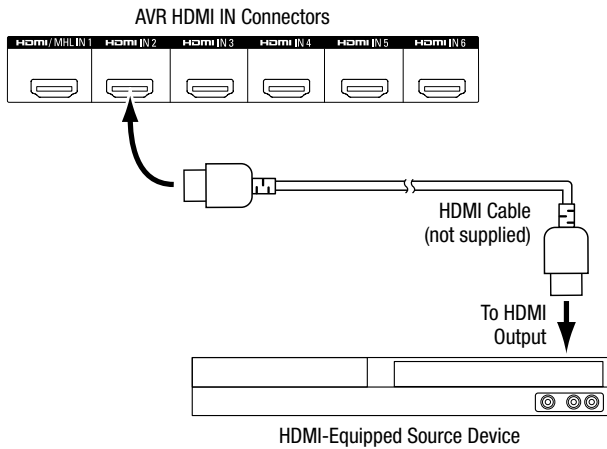

Composite Video Devices

Use composite video connectors for video source devices that don't have HDMI or component video connectors. You will also need to make an audio connection from the source device to the AVR.

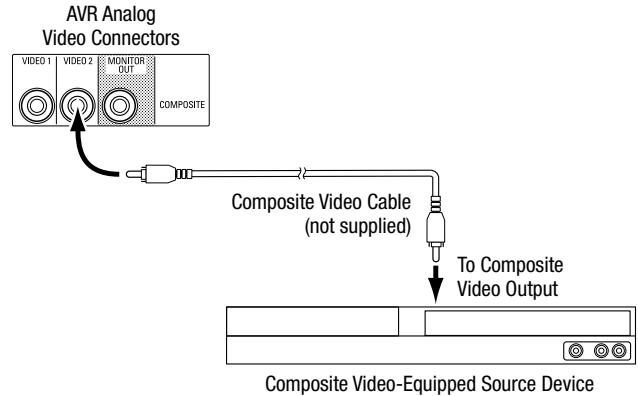

Optical Digital Audio Devices

If your non-HDMI source devices have optical digital outputs, connect them to the AVR's optical digital audio connectors. **NOTE:** Make only one type of digital connection (HDMI, optical or coaxial) from each source device.

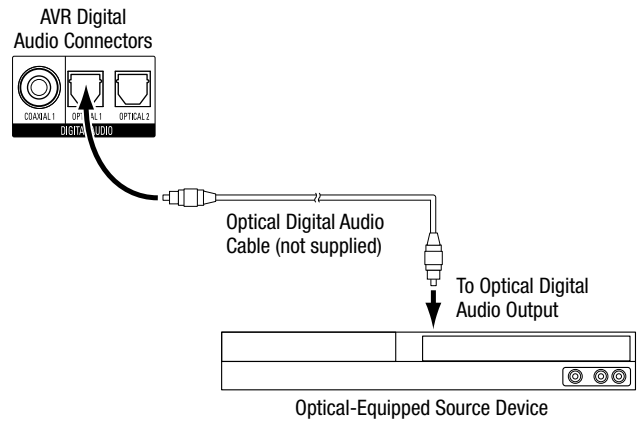

Coaxial Digital Audio Devices

If any of your non-HDMI source devices have coaxial digital outputs, connect them to the AVR's coaxial digital audio connector. **NOTE:** Make only one type of digital connection (HDMI, optical or coaxial) from each source device.

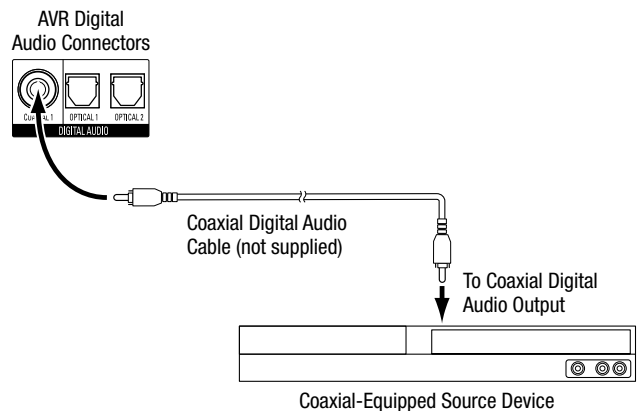

Analog Audio Devices

Use the AVR's analog audio connectors for source devices that don't have HDMI or digital audio connectors.

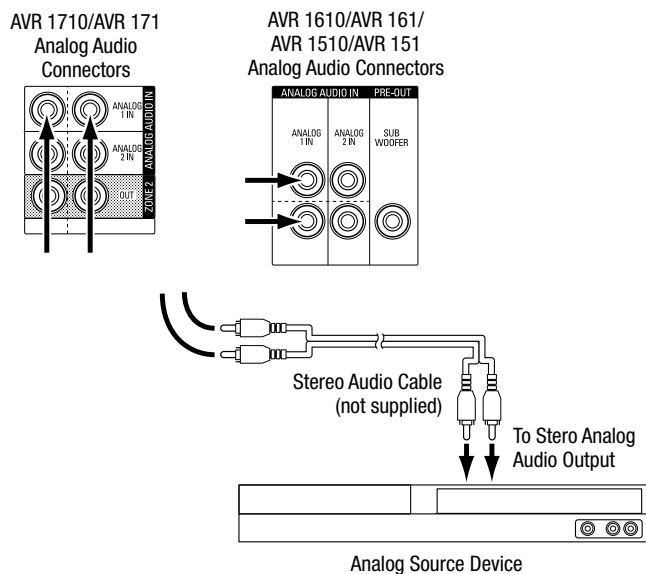

USB and iOS Devices

Use the AVR's front-panel USB port to connect an iPod, iPhone or iPad using an Apple cable (not supplied) or to directly connect a USB memory stick. You can play audio files from the device or memory stick and use the AVR's remote to control playback.

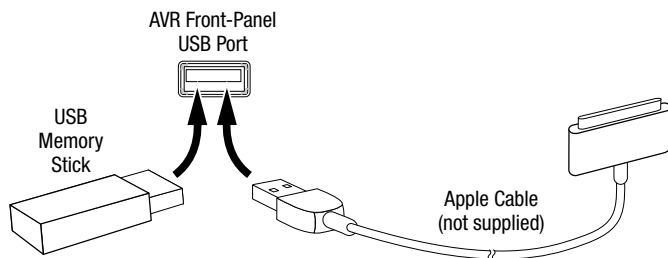

Connect Your Home Network

Use a Cat. 5 or Cat. 5E cable (not supplied) to connect the AVR's Network connector to your home network to enjoy AirPlay™, Internet radio and content from DLNA®-compatible devices that are connected to the network.

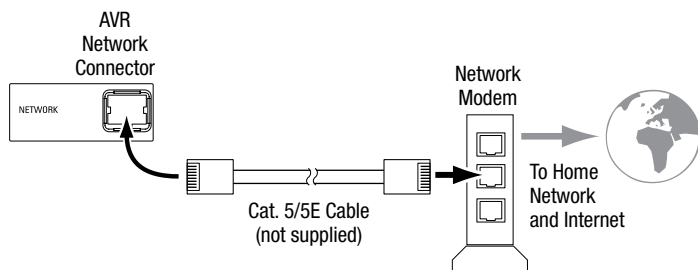

Connect the Radio Antennas

- Connect the supplied FM antenna to the AVR's FM 75Ω antenna connector. For the best reception, extend the FM antenna as far as possible.
- Bend and fold the base of the supplied AM antenna as shown and connect the antenna wires to the AVR's AM and Gnd connectors. (You can connect either wire to either connector.) Rotate the antenna as necessary to minimize background noise.

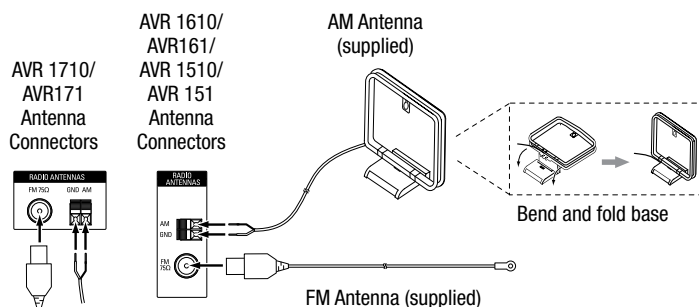

NOTE: To connect multi-zone, remote IR and trigger equipment, please download the *AVR 1710/AVR 171-230/AVR 171-230C/AVR 1610/AVR 161-230/AVR 161-230C Owner's Manual* or the *AVR 1510/AVR 151-230/AVR 151-230C Owner's Manual* from www.harmaninternational.com.

Connect to AC Power

AVR 171/AVR 161/AVR 151:

Connect the supplied AC power cord to the AVR's AC Input connector and then to a working, non-switched AC power outlet.

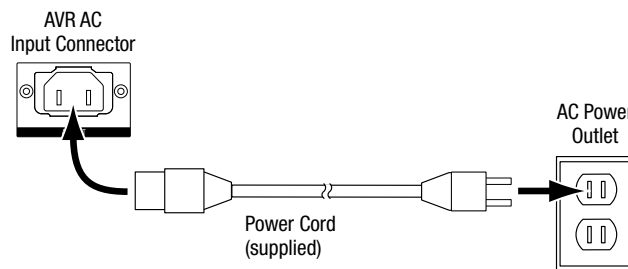

AVR 1710/AVR 1610/AVR 1510:

Connect the AVR's power cord to a working, nonswitched AC power outlet.

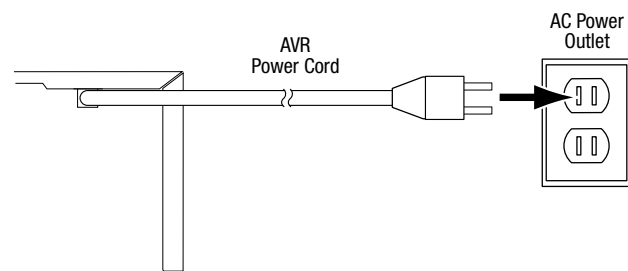

Set Up the AVR

Install the Batteries in the Remote Control

Remove the remote control's battery cover, insert the two supplied AAA batteries as shown in the illustration, and replace the battery cover.

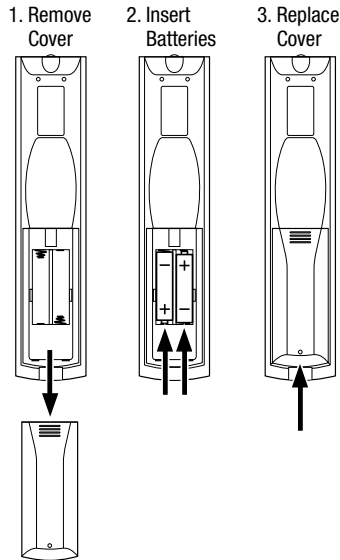

NOTE: Remove the protective plastic from the AVR's front panel so it doesn't reduce the remote control's effectiveness.

Using the Remote Control

You will be using the following remote control buttons to configure your AVR:

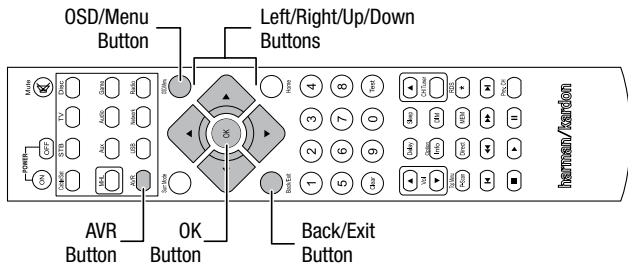

Turn On the AVR

Press the front-panel Power button.

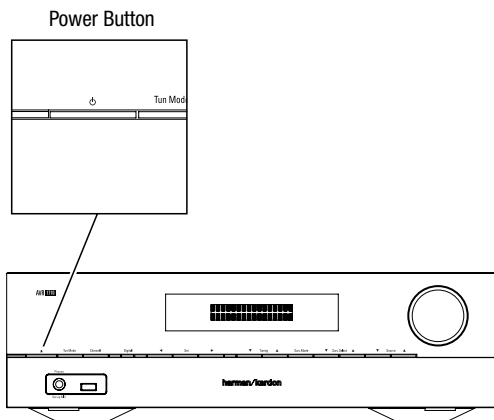

Configure the AVR for Your Speakers: AVR 1710/AVR 171/AVR 1610/AVR 161

Note: The on-screen menus shown in this guide may differ slightly from your AVR's actual menu screens.

Before you use your AVR you need to configure it to work with your particular speaker system. Your AVR's EZSet/EQ™ Plus system uses the supplied EzSet/EQ microphone to automatically detect the capabilities of each connected speaker and optimize the AVR's performance for them. Before beginning, be sure you have correctly connected your speakers to the AVR.

1. Plug the supplied EzSet/EQ™ microphone into the AVR's Headphone connector.

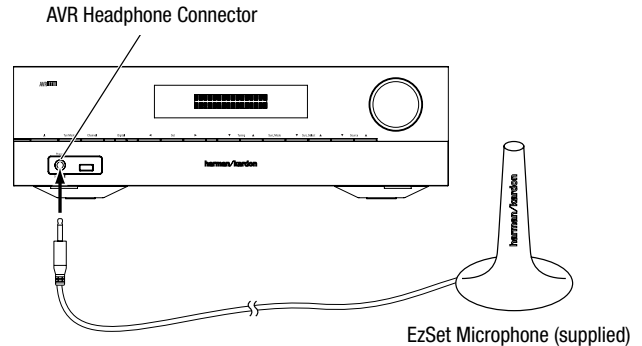

2. Place the microphone at ear height in your listening position.
3. Turn on your TV and select the TV input where you connected the AVR in *Connect Your TV*, on page 3.
4. Press the remote control's AVR button, then press the OSD/Menu button. The AVR's on-screen display (OSD) setup menu will appear on the TV. (Note: If you have used a composite video connection to your TV, the OSD menus will not appear on your TV. Follow the steps below using the AVR's front-panel display.)

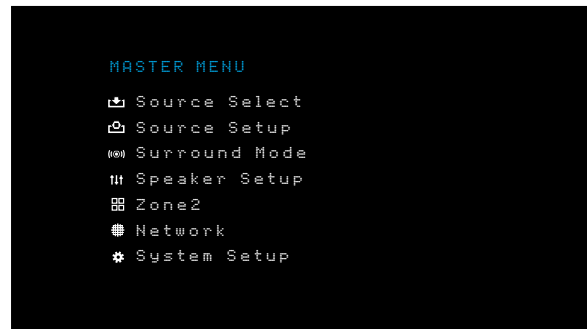

5. Use the remote's arrow and OK buttons to select "Speaker Setup."

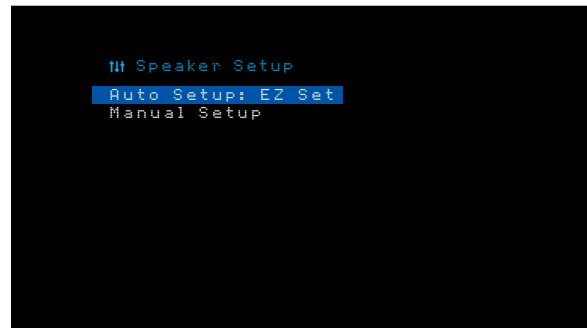

6. Select "Auto Setup: EZ Set."
7. Select "Continue."
8. Follow the instructions that appear on the screens. Remain quiet while the test noise plays through the speakers.

Configure the AVR for Your Speakers: AVR 1510/AVR 151

Note: The on-screen menus shown in this guide may differ slightly from your AVR's actual menu screens.

Before you use your AVR you need to configure it to work with your speakers and to compensate for the acoustic characteristics of your room. Before beginning, place your loudspeakers as explained in the *Place Your Speakers* section, on page 2, and connect them to the AVR as explained in the *Connect Your Speakers* section, on page 3.

1. Turn on your TV and select the TV input where you connected the AVR in Connect Your TV, on page 3.

2. Press the remote control's OSD/Menu button. The AVR's on-screen display (OSD) setup menu will appear on the TV. (Note: If you have used a composite video connection to your TV, the OSD menus will not appear on your TV. Follow the steps below using the AVR's front-panel display.)

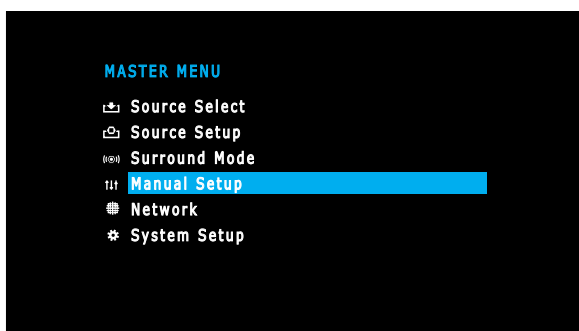

3. Use the remote's arrow and OK buttons to select "Manual Setup."

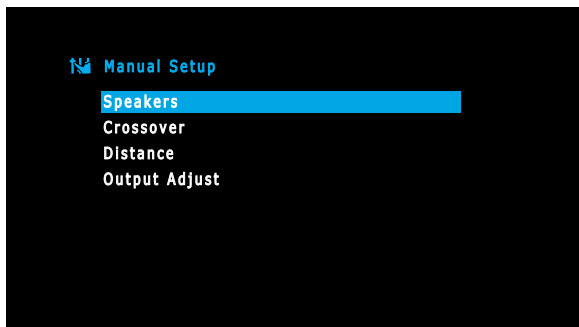

4. Select "Speakers."

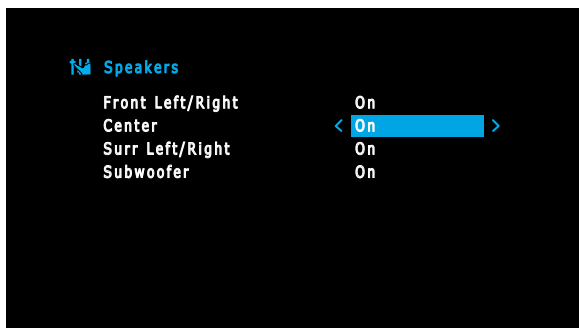

5. Use the Up/Down buttons to select a speaker group and use the Left/Right buttons to select "On" when the speakers are present in the system, or "Off" for positions where no speakers are installed. The Front Left & Right setting is always On and may not be disabled. (Note: The settings in this menu affect the remainder of the speaker setup process and the availability of various surround modes.)

6. Press the Back/Exit button to return to the Manual Setup screen, then select "Crossover."

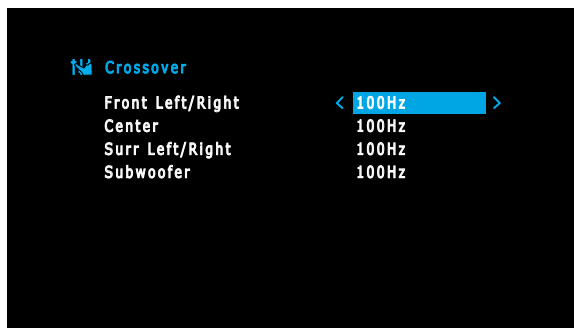

Consult the technical specifications for all of your speakers and locate their frequency response, usually given as a range, e.g., 100Hz – 20kHz (±3dB). Write down the lowest frequency that each of your speakers is capable of playing (100Hz in the above example).

7. Use the Left/Right buttons to set each speaker group's Crossover Frequency to the frequency that most closely matches the frequency you noted above in the speaker's specifications. If the speaker's crossover frequency is lower than 40Hz, select the first option, "Large." (This setting doesn't refer to the speaker's physical size but to its frequency response, which is also called "full range.")

- We recommend that you set the Subwoofer Crossover to the same frequency you use for the Front Left/Right speaker setting.

Your AVR will divide the source signal at the crossover frequency; all information above that crossover point will be played through your system's speakers, and all information below the crossover point will be played through the subwoofer. This way, each loudspeaker in your system will perform at its best, delivering a more powerful and enjoyable sound experience.

- If you set the Front Left/Right speakers to "Large", select one of the three following settings for the subwoofer:

L/R+LFE: This setting sends all low-frequency information to the subwoofer, including a) low-frequency information that is also played through the front left and right speakers and b) the special LFE (low-frequency effects) channel information that is present on some DVDs, Blu-ray discs and other digital programming.

LFE: This setting plays low-frequency information contained in the full-range program channels through the front left and right speakers, and directs only the LFE-channel information to the subwoofer.

OFF: Select this setting when no subwoofer is in use. All low-frequency information will be sent to the front left and right speakers.

8. When you're finished, press the Back/Exit button to return to the Manual Setup screen, then select "Distance."

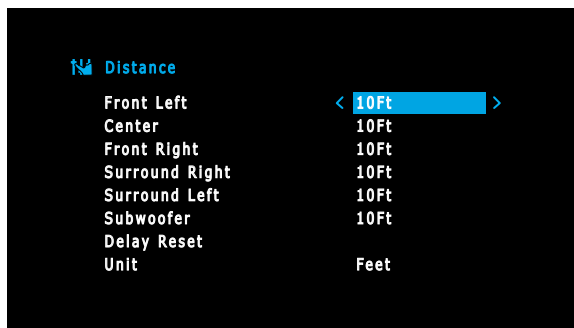

9. Measure the distance from each speaker to the listening position, and write it down. (Even if all of your speakers are the same distance from the listening position, you will need to do this.)
10. Enter the distance that you measured from each speaker to the listening position. Select a speaker, then use the Left/Right buttons to change the measurement. You can enter distances between 0 and 30 feet (9.1m). The default distance for all speakers is 10 feet.
 - If you want to use metric measurements, select “Unit” and use the Left/Right buttons to change the units to meters.
11. When you’re finished, press the OSD/Menu button to exit the menu system.

Assign Connectors to the AVR’s Source Buttons

1. Review the input connections you listed on the *Source Buttons and Assigned Connectors* table, on page 4. Note what changes (if any) you want to make from the default connector assignments that appear on the list.
2. Turn on your TV and select the TV input where you connected the AVR in *Connect Your TV*, on page 3.
3. Press the remote control’s OSD/Menu button. The AVR’s on-screen display (OSD) setup menu will appear on the TV. (Note: If you have used a composite video connection to your TV, the OSD menus will not appear on your TV. Follow the steps below using the AVR’s front-panel display.)

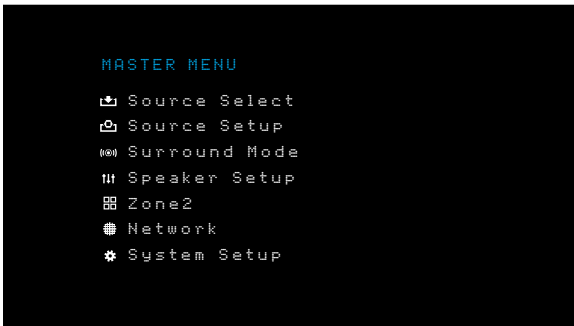

4. Use the remote’s arrow and OK buttons to select “Source Setup” and use the left/right arrow buttons to select a source button with connectors that you want to re-assign.

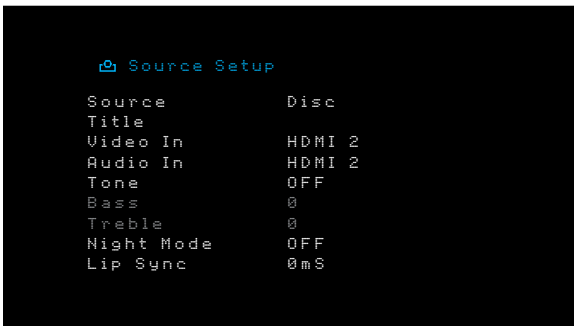

5. Select “Video In” and select the video input connector you want to assign to the source button. Press the OK button. NOTE: If you select an HDMI connector as the Video Input, the Audio Input will automatically change to the same HDMI connector. You cannot use a different audio input with an HDMI video input.

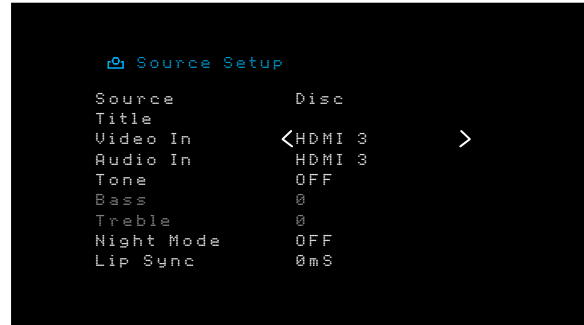

6. If you have not selected an HDMI connection for Video In, select “Audio In” and select the audio input connector you want to assign to the source button. Press the OK button.

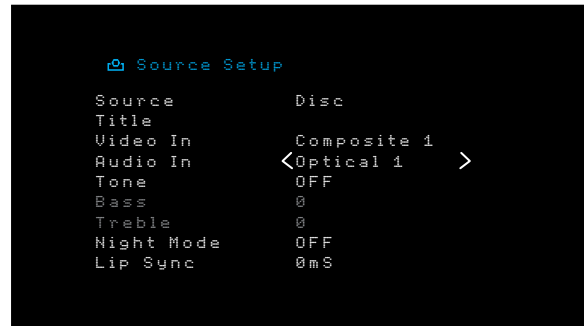

7. Press the remote’s Back/Exit button and repeat steps 3 – 6 for the remaining source buttons with connectors you want to re-assign.

You are now ready to enjoy your AVR!

IMPORTANT: For complete information about using all of your audio/video AVR’s features and capabilities, download the *AVR 1710/AVR 1610/AVR 171-230/AVR 161-230/AVR 171-230C/AVR 161-230C Owner’s Manual* or *AVR 1510/AVR 151-230/AVR 151-230C Owner’s Manual* from www.harmanardon.com.

For easy control of your AVR with a hand-held device, download the free app from iTunes App Store for compatible Apple products, or from Google Play for compatible Android powered smartphones and tablets.

General Specifications

Power consumption	
(AVR 1710/AVR 171):	<0.5W (standby); XXXW (maximum)
(AVR 1610/AVR 161):	<0.5W (standby); XXXW (maximum)
(AVR 1510/AVR 151):	<0.5W (standby); XXXW (maximum)
Dimensions (W x H x D):	
	17-5/16" x XX" x XX" (440mm x XXmm x XXmm)
Weight	
(AVR 1710/AVR 171):	XX lb (XXkg)
(AVR 1610/AVR 161):	XX lb (XXkg)
(AVR 1510/AVR 151):	XX lb (XXkg)



HARMAN

HARMAN International Industries, Incorporated
8500 Balboa Boulevard, Northridge, CA 91329 USA
516.255.4545 (USA only)

Made in P.R.C.

© 2013 HARMAN International Industries, Incorporated. All rights reserved.

Harman Kardon is a trademark of HARMAN International Industries, Incorporated, registered in the United States and/or other countries. EzSet/EQ is a trademark of HARMAN International Industries, incorporated.

Android is a trademark of Google Inc. Use of this trademark is subject to Google Permissions.

Apple, iPhone, iPod, iPod touch, iTunes and Macintosh are trademarks of Apple Inc., registered in the U.S. and other countries.

DLNA is a registered trademark of the Digital Living Network Alliance.

Manufactured under license under U.S. Patent Nos: 5,956,674; 5,974,380; 6,226,616; 6,487,535; 7,212,872; 7,333,929; 7,392,195; 7,272,567 & other U.S. and worldwide patents issued & pending. DTS-HD, the Symbol, & DTS-HD and the Symbol together are registered trademarks of DTS, Inc. Product includes software. © DTS, Inc. All Rights Reserved.

Manufactured under license from Dolby Laboratories. Dolby, Pro Logic, and the double-D symbol are trademarks of Dolby Laboratories.

Google is a trademark of Google Inc.

HDMI, the HDMI logo and High-Definition Multimedia Interface are trademarks or registered trademarks of HDMI Licensing LLC in the United States and other countries.

Roku is a registered trademarks of Roku, Inc. All rights reserved.

Features, specifications and appearance are subject to change without notice.

Part #: 960-0287-001, Rev. A

harman/kardon
by HARMAN

www.harmankardon.com

IMPORTANT SAFETY INSTRUCTIONS

For All Products:

1. Read these instructions.
2. Keep these instructions.
3. Heed all warnings.
4. Follow all instructions.
5. Do not use this apparatus near water.
6. Clean only with a dry cloth.
7. Do not block any ventilation openings. Install this apparatus in accordance with the manufacturer's instructions.
8. Do not install this apparatus near any heat sources such as radiators, heat registers, stoves or other apparatus (including amplifiers) that produce heat.
9. Do not defeat the safety purpose of the polarized or grounding-type plug. A polarized plug has two blades with one wider than the other. A grounding-type plug has two blades and a third grounding prong. The wide blade or the third prong is provided for your safety. If the provided plug does not fit into your outlet, consult an electrician for replacement of the obsolete outlet.
10. Protect the power cord from being walked on or pinched, particularly at plugs, convenience receptacles and the point where they exit from the apparatus.
11. Use only attachments/accessories specified by the manufacturer.
12. Use only with the cart, stand, tripod, bracket or table specified by the manufacturer or sold with the apparatus.  When a cart is used, use caution when moving the cart/apparatus combination to avoid injury from tip-over.
13. Unplug this apparatus during lightning storms or when unused for long periods of time.
14. Refer all servicing to qualified service personnel. Servicing is required when the apparatus has been damaged in any way, such as when the power-supply cord or plug is damaged, liquid has been spilled or objects have fallen into the apparatus, or the apparatus has been exposed to rain or moisture, does not operate normally or has been dropped.
15. Do not expose this apparatus to dripping or splashing, and ensure that no objects filled with liquids, such as vases, are placed on the apparatus.
16. To disconnect this apparatus from the AC mains completely, disconnect the power-supply cord plug from the AC receptacle.
17. The mains plug of the power-supply cord shall remain readily operable.
18. Do not expose batteries to excessive heat such as sunshine, fire or the like.

CAUTION

RISK OF ELECTRIC SHOCK. DO NOT OPEN.



THE LIGHTNING FLASH WITH AN ARROWHEAD SYMBOL, WITHIN AN EQUILATERAL TRIANGLE, IS INTENDED TO ALERT THE USER TO THE PRESENCE OF UNINSULATED "DANGEROUS VOLTAGE" WITHIN THE PRODUCT'S ENCLOSURE THAT MAY BE OF SUFFICIENT MAGNITUDE TO CONSTITUTE A RISK OF ELECTRIC SHOCK TO PERSONS.



THE EXCLAMATION POINT WITHIN AN EQUILATERAL TRIANGLE IS INTENDED TO ALERT THE USER TO THE PRESENCE OF IMPORTANT OPERATING AND MAINTENANCE (SERVICING) INSTRUCTIONS IN THE LITERATURE ACCOMPANYING THE PRODUCT.

WARNING: TO REDUCE THE RISK OF FIRE OR ELECTRIC SHOCK, DO NOT EXPOSE THIS APPARATUS TO RAIN OR MOISTURE.

occur in a particular installation. If this equipment does cause harmful interference to radio or television reception, which can be determined by turning the equipment off and on, the user is encouraged to try to correct the interference by one or more of the following measures:

- Reorient or relocate the receiving antenna.
- Increase the separation between the equipment and receiver.
- Connect the equipment into an outlet on a circuit different from that to which the receiver is connected.
- Consult the dealer or an experienced radio/TV technician for help.

Caution: Changes or modifications not expressly approved by HARMAN could void the user's authority to operate the equipment.

For Products That Transmit RF Energy:

FCC AND IC INFORMATION FOR USERS

This device complies with Part 15 of the FCC rules and Industry Canada license-exempt RSS 210. Operation is subject to the following two conditions: (1) This device may not cause harmful interference; and (2) this device must accept any interference received, including interference that may cause undesired operation.

FCC/IC Radiation Exposure Statement

This equipment complies with FCC/IC RSS-102 radiation exposure limits set forth for an uncontrolled environment. This equipment should be installed and operated with minimum distance 20cm between the radiator & your body.

FCC AND IC STATEMENT FOR USERS (USA AND CANADA ONLY)

This device complies with part 15 of the FCC Rules. Operation is subject to the following two conditions: (1) This device may not cause harmful interference, and (2) this device must accept any interference received, including interference that may cause undesired operation.

This Class B digital apparatus complies with Canadian ICES-003.

Cet appareil numérique de la classe B est conforme à la norme NMB-003 du Canada.

Federal Communication Commission Interference Statement

This equipment has been tested and found to comply with the limits for a Class B digital device, pursuant to Part 15 of the FCC Rules. These limits are designed to provide reasonable protection against harmful interference in a residential installation. This equipment generates, uses and can radiate radio frequency energy and, if not installed and used in accordance with the instructions, may cause harmful interference to radio communications. However, there is no guarantee that interference will not

For Products with Radio Receivers That Can Use an External Antenna (USA ONLY):

CATV (Cable TV) or Antenna Grounding

If an outside antenna or cable system is connected to this product, be certain that it is grounded so as to provide some protection against voltage surges and static charges. Section 810 of the National Electrical Code (NEC), ANSI/NFPA No. 70-1984, provides information with respect to proper grounding of the mast and supporting structure, grounding of the lead-in wire to an antenna discharge unit, size of grounding conductors, location of antenna discharge unit, connection to grounding electrodes and requirements of the grounding electrode.

Note to CATV System Installer:

This reminder is provided to call the CATV (cable TV) system installer's attention to article 820-40 of the NEC, which provides guidelines for proper grounding and, in particular, specifies that the cable ground shall be connected to the grounding system of the building, as close to the point of cable entry as possible.

IMPORTANT SAFETY INSTRUCTIONS

For CD/DVD/Blu-ray Disc™ Players:

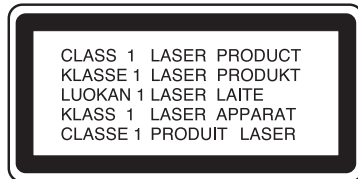

Caution:

This product uses a laser system. To prevent direct exposure to the laser beam, do not open the cabinet enclosure or defeat any of the safety mechanisms provided for your protection. **DO NOT STARE INTO THE LASER BEAM.** To ensure proper use of this product, please read the owner's manual carefully and retain it for future use. Should the unit require maintenance or repair, please contact your local Harman Kardon service center. Refer servicing to qualified personnel only.

FOR ALL EU COUNTRIES:

For products that include audio out

Prevention of hearing loss

Caution: Permanent hearing loss may occur if earphones or headphones are used at high volume for prolonged periods of time.

For France, the products have been tested to comply with the Sound Pressure Level requirement laid down in the applicable NF EN50332-1:2000 and/or EN50332-2:2003 standards as required by French Article L.5232-1.



Note: To prevent possible hearing damage, do not listen at high volume levels for long periods.

WEEE Notice

The Directive on Waste Electrical and Electronic Equipment (WEEE), which entered into force as European law on 13th February 2003, resulted in a major change in the treatment of electrical equipment at end-of-life.

The purpose of this Directive is, as a first priority, the prevention of WEEE, and in addition, to promote the reuse, recycling and other forms of recovery of such wastes so as to reduce disposal.

The WEEE logo on the product or on its box indicating collection for electrical and electronic equipment consists of the crossed-out wheeled bin, as shown below.



This product must not be disposed of or dumped with your other household waste. You are liable to dispose of all your electronic or electrical waste equipment by relocating over to the specified collection point for recycling of such hazardous waste. Isolated collection and proper recovery of your electronic and electrical waste equipment at the time of disposal will allow us to help conserving natural resources. Moreover, proper recycling of the electronic and electrical waste equipment will ensure safety of human health and environment. For more information about electronic and electrical waste equipment disposal, recovery, and collection points, please contact your local city center, household waste disposal service, shop from where you purchased the equipment, or manufacturer of the equipment.

RoHS Compliance

This product is in compliance with Directive 2011/65/EU of the European Parliament and of the Council of 8 June 2011 on the restriction of the use of certain hazardous substances in electrical and electronic equipment.

For Products That Include Batteries

EU Batteries Directive 2006/66/EC

A new battery directive 2006/66/EC on Battery and Accumulator replacing directive entered into force on the 26th September 2008. The directive applies to all types of batteries and accumulators (AA, AAA, button cells, lead acid, rechargeable packs) including those incorporated into appliances except for military, medical and power tool applications.

The directive sets out rules for collection, treatment, recycling and disposal of batteries, and aims to prohibit certain hazardous substances and to improve environmental performance of batteries and all operators in the supply chain.

Instructions for Users on Removal, Recycling and Disposal of Used Batteries

To remove the batteries from your equipment or remote control, reverse the procedure described in the owner's manual for inserting batteries.

For products with a built-in battery that lasts for the lifetime of the product, removal may not be possible for the user. In this case, recycling or recovery centers handle the dismantling of the product and the removal of the battery. If, for any reason, it becomes necessary to replace such a battery, this procedure must be performed by authorized service centers.

In the European Union and other locations, it is illegal to dispose of any battery with household trash. All batteries must be disposed of in an environmentally sound manner. Contact your local waste-management officials for information regarding the environmentally sound collection, recycling and disposal of used batteries.

WARNING: Danger of explosion if battery is incorrectly replaced. To reduce risk of fire or burns, don't disassemble, crush, puncture, short external contacts, expose to temperature above 60°C (140°F), or dispose of in fire or water. Replace only with specified batteries.

The symbol indicating 'separate collection' for all batteries and accumulators shall be the crossed-out wheeled bin shown below:



In case of batteries, accumulators and button cells containing more than 0.0005 % mercury, more than 0.002 % cadmium or more than 0.004 % lead, shall be marked with the chemical symbol for the metal concerned: Hg, Cd or Pb respectively. Please Refer to the below symbol:

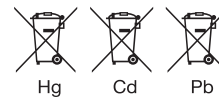

For All Products Except Those with Wireless Operation:

HARMAN International hereby declares that this equipment is in compliance with the EMC 2004/108/EC Directive, LVD 2006/95/EC Directive, ErP 2009/125/EC Directive and RoHS 2011/65/EU Directive. The declaration of conformity may be consulted in the support section of our Web site, accessible from www.harmankardon.com.

For All Products with Wireless Operation:

HARMAN International hereby declares that this equipment is in compliance with the essential requirements and other relevant provisions of Directive 1999/5/EC, ErP 2009/125/EC Directive and RoHS 2011/65/EU Directive. The declaration of conformity may be consulted in the support section of our Web site, accessible from www.harmankardon.com.

HARMAN

HARMAN International Industries, Incorporated
8500 Balboa Boulevard, Northridge, CA 91329 USA
516.255.4545 (USA only)

© 2012 HARMAN International Industries, Incorporated. All rights reserved.

Harman Kardon is a trademark of HARMAN International Industries, Incorporated, registered in the United States and/or other countries. Blu-ray Disc is a trademark of the Blu-ray Disc Association. Features, specifications and appearance are subject to change without notice.

www.harmankardon.com