



UNITY[®] XG-100P Full-Spectrum Multiband Radio



MANUAL REVISION HISTORY

REV.	DATE	REASON FOR CHANGE
B	Mar/11	Added P25 Trunking and updated for R2.
C	Jul/11	Updated noise-cancelling information.
D	Sep/11	Updated accessories.
E	Oct/11	Updated accessories.

Harris Corporation, Public Safety and Professional Communications (PSPC) Business continually evaluates its technical publications for completeness, technical accuracy, and organization. You can assist in this process by submitting your comments and suggestions to the following:

Harris Corporation fax your comments to: 1-434-455-6851
 PSPC Business or
 Technical Publications e-mail us at: PSPC_TechPubs@harris.com
 221 Jefferson Ridge Parkway
 Lynchburg, VA 24501

ACKNOWLEDGEMENT

This product was developed using GEOTRANS, a product of the National Geospatial Intelligence Agency and U.S. Army Engineering Research and Development Center. Use of this software does not indicate endorsement or approval of the product by the Secretary of Defense or the National Geospatial Intelligence Agency.

This device made under license under one or more of the following US patents: 4,590,473; 4,636,791; 5,148,482; 5,185,796; 5,271,017; 5,377,229; 4,716,407; 4,972,460; 5,502,767; 5,146,697; 5,164,986; 5,185,795.

The Advanced Multi-Band Excitation implementation 2 (AMBE+2) voice coding Technology embodied in this product is protected by intellectual property rights including patent rights, copyrights and trade secrets of Digital Voice Systems, Inc. This voice coding Technology is licensed solely for use within this Communications Equipment. The user of this Technology is explicitly prohibited from attempting to extract, remove, decompile, reverse engineer, or disassemble the Object Code, or in any other way convert the Object Code into a human-readable form. U.S. Patent Nos. #5,870,405, #5,826,222, #5,754,974, #5,701,390, #5,715,365, #5,649,050, #5,630,011, #5,581,656, #5,517,511, #5,491,772, #5,247,579, #5,226,084 and #5,195,166.

CREDITS

Harris, assuredcommunications, VIDA, EDACS, NetworkFirst, and OpenSky are registered trademarks of Harris Corporation. Bluetooth is a registered trademark of Bluetooth SIG, Inc. All brand and product names are trademarks, registered trademarks, or service marks of their respective holders. Motorola is a registered trademark of Motorola, Inc. AMBE is a registered trademark and IMBE, AMBE+, and AMBE+2 are trademarks of Digital Voice Systems, Inc.

NOTICE!

The material contained herein is subject to U.S. export approval. No export or re-export is permitted without written approval from the U.S. Government. Rated: EAR99; in accordance with U.S. Dept. of Commerce regulations 15CFR774, Export Administration Regulations.

Information and descriptions contained herein are the property of Harris Corporation. Such information and descriptions may not be copied or reproduced by any means, or disseminated or distributed without the express prior written permission of Harris Corporation, PSPC Business, 221 Jefferson Ridge Parkway, Lynchburg, VA 24501.

Repairs to this equipment should be made only by an authorized service technician or facility designated by the supplier. Any repairs, alterations or substitutions of recommended parts made by the user to this equipment not approved by the manufacturer could void the user's authority to operate the equipment in addition to the manufacturer's warranty.



This product conforms to the European Union WEEE Directive 2002/96/EC. Do not dispose of this product in a public landfill. Take it to a recycling center at the end of its life.

This manual is published by **Harris Corporation** without any warranty. Improvements and changes to this manual necessitated by typographical errors, inaccuracies of current information, or improvements to programs and/or equipment, may be made by **Harris Corporation** at any time and without notice. Such changes will be incorporated into new editions of this manual. No part of this manual may be reproduced or transmitted in any form or by any means, electronic or mechanical, including photocopying and recording, for any purpose, without the express written permission of **Harris Corporation**.

TABLE OF CONTENTS

<i>Section</i>	<i>Page</i>
1. REGULATORY AND SAFETY INFORMATION.....	6
1.1 SAFETY SYMBOL CONVENTIONS	6
1.2 FCC INFORMATION.....	7
2. INTRODUCTION	8
2.1 DESCRIPTION	8
2.2 STORAGE GUIDELINES	8
3. BASIC SETUP	9
3.1 ASSEMBLE THE RADIO	9
3.2 REMOVING THE BATTERY.....	10
3.3 REMOVING THE OPTION BELT CLIP	10
4. BASIC OPERATION.....	11
4.1 XG-100P CONTROLS	11
4.2 TOP DISPLAY	12
4.3 MAIN DISPLAY.....	13
4.4 STATUS MESSAGES	14
4.5 MENU NAVIGATION	15
4.6 BEFORE FIRST USE.....	15
4.7 POWER ON AND SET VOLUME.....	15
4.8 NOISE CANCELLATION.....	16
4.8.1 Enable Noise Cancellation and Voice Assist.....	16
4.8.2 Using Noise Cancellation	17
4.8.3 The Effect of Distance from the Microphone.....	17
4.8.4 Primary versus Secondary Microphone.....	18
4.9 SELECT CHANNEL AND BANK.....	18
4.10 TURN ENCRYPTION ON OR OFF.....	19
4.11 USER INTERFACE PRIVILEGE LEVEL	19
4.12 SELECT ZONE/SYSTEM USING MENUS	20
4.13 USE TALKAROUND TO BYPASS REPEATER (CONVENTIONAL ONLY)	21
4.14 INDIVIDUAL CALLS	22
4.14.1 Transmit an Individual Call	22
4.14.2 Receiving an Individual Call	23
4.15 GROUP CALLS	24
4.15.1 Transmit a Group Call	24
4.15.2 Receive a Group Call.....	24
4.16 START SCAN	25
4.17 STOP SCAN.....	25
4.18 NUISANCE DELETE	26
4.19 VIEW GPS INFORMATION.....	27
4.20 EMERGENCY OPERATION.....	28
4.20.1 Declaring an Emergency Call.....	28
4.20.2 Receiving an Emergency Call	29
4.21 ENCRYPTION BAR.....	29
4.22 OTAR SCREENS.....	29
5. ADVANCED OPERATIONS	30
5.1 CREATE KEYS	30

5.1.1	Create Keys using Harris Key Admin	30
5.1.2	Create Key in the KVL 3000 Plus	30
5.1.3	Create Keygroup in the KVL 3000 Plus	31
5.2	LOAD KEYS	31
5.2.1	Load UKEKs with UKEK Loader and RPM (for OTAR-Enabled Systems)	31
5.2.2	Load Keys using Harris Key Loader	32
5.2.3	Load Keys using Motorola KVL 3000 Plus	33
5.3	LOAD KEYGROUPS	34
5.4	ZEROIZE ALL FROM RADIO	35
5.5	ZEROIZE KEYS USING KVL 3000 PLUS	36
5.6	ZEROIZE KEYGROUPS USING KVL 3000 PLUS	36
5.7	ZEROIZE ALL FROM KVL 3000 PLUS	37
5.8	GLOBAL ENCRYPTION	38
5.9	SELECT KEYSSET	39
5.10	OTAR CONFIGURATION	39
5.11	ACTIVATE/VIEW MISSION PLAN	40
5.12	CH INFO MENU	41
5.13	SETTINGS MENU	41
5.13.1	Audio Settings	42
5.13.2	Display Settings	43
5.13.3	GPS Settings	44
5.13.4	Bluetooth	45
5.13.5	Clock Settings	47
5.13.6	Battery Settings	48
5.14	SHORTCUT MENU	49
5.14.1	Start or Stop Scan (Shortcut Menu)	49
5.14.2	Monitor and Squelch Types (Conventional Only)	49
5.14.3	Nuisance Delete	50
5.14.4	Select Channel/Group	51
5.14.5	Lock Keypad	51
5.14.6	TX Power Low/High	52
5.14.7	Display GPS	52
5.15	SET UP SCAN	52
5.15.1	Home, Priority 1, and Priority 2 Channels	53
5.15.2	Zone Scan	53
5.15.3	Group Scan	53
5.15.4	Vote Scan	54
5.15.5	Edit Scan List	54
5.15.6	Set or Remove Priority 1 and Priority 2 Channels	55
5.15.7	Wide Area System Scan (P25 Trunked Only)	56
5.16	MESSAGE MENU	56
5.17	UTILITY MENU	57
6.	PROGRAMMING	61
6.1	PROGRAMMING VIA RPM	61
6.2	EDIT CHANNEL (CONVENTIONAL ONLY)	61
6.3	PROGRAMMABLE HOT KEY AND BUTTONS	63
7.	REFERENCE	64
7.1	MARINE FREQUENCIES	64
7.2	ACCESSORIES	70

8. GLOSSARY	71
9. BASIC TROUBLESHOOTING	74
9.1 ERROR MESSAGES	74
9.2 OTAR ERRORS/INFORMATION	75
10. TECHNICAL ASSISTANCE	77
11. RECHARGEABLE BATTERY WARRANTY	78
12. WARRANTY	79

LIST OF FIGURES

	<i>Page</i>
Figure 3-1: Radio Assembly	9
Figure 3-2: Remove the Battery	10
Figure 3-3: Remove Belt Clip	10
Figure 4-1: XG-100P Controls	11
Figure 4-2: Top Display	12
Figure 4-3: Main Display	13
Figure 4-4: Enable Noise Cancellation and Voice Assist	16
Figure 4-5: Using the Noise Cancellation Feature	17
Figure 4-6: Without a Speaker Microphone Attached	18
Figure 4-7: With a Speaker Microphone Attached	18
Figure 4-8: User Interface Privilege	19
Figure 4-9: Unit ID	24
Figure 4-10: Group ID	24

LIST OF TABLES

	<i>Page</i>
Table 4-1: XG-100P Controls, Indicators, and Connectors	11
Table 4-2: Status Messages	14
Table 4-3: Encryption Bar Indications	29
Table 4-4: OTAR Display Messages	29
Table 5-1: Alert Tones	43
Table 6-1: Valid Frequencies	63
Table 7-1: Marine Frequencies	64
Table 7-2: Options and Accessories	70

1. REGULATORY AND SAFETY INFORMATION

1.1 SAFETY SYMBOL CONVENTIONS

The following conventions are used to alert the user to general safety precautions that must be observed during all phases of operation, service, and repair of this product. Failure to comply with these precautions or with specific warnings elsewhere violates safety standards of design, manufacture, and intended use of the product. Harris Corporation assumes no liability for the customer's failure to comply with these standards.



The **WARNING** symbol calls attention to a procedure, practice, or the like, which, if not correctly performed or adhered to, could result in personal injury. Do not proceed beyond a **WARNING** symbol until the conditions identified are fully understood or met.



The **CAUTION** symbol calls attention to an operating procedure, practice, or the like, which, if not performed correctly or adhered to, could result in a risk of danger, damage to the equipment, or severely degrade the equipment performance.



The **NOTE** symbol calls attention to supplemental information, which may improve system performance or clarify a process or procedure.



The **ESD** symbol calls attention to procedures, practices, or the like, which could expose equipment to the effects of Electro-Static Discharge. Proper precautions must be taken to prevent ESD when handling circuit modules.



The electrical hazard symbol is a **WARNING** indicating there may be an electrical shock hazard present.

1.2 FCC INFORMATION



Before operating the XG-100P radio, read the safety and RF exposure guidelines contained in safety booklet, 10515-0372-4000, included with your radio.

The XG-100P has been tested and complies with the Federal Communications Commission (FCC) RF exposure limits for “Occupational Use Only.” In addition, this radio complies with the following Standards and Guidelines with regard to RF energy and electromagnetic energy levels and evaluation of such levels for exposure to humans:

FCC Office of Engineering and Technology (OET) Bulletin 65 Edition 97-01 Supplement C, Evaluating Compliance with FCC Guidelines for Human Exposure to Radio Frequency Electromagnetic Fields

American National Standards Institute (ANSI) (C95.1 – 1992), Institute of Electrical & Electronics Engineers (IEEE) Standard for Safety Levels with Respect to Human Exposure to Radio Frequency Electromagnetic Fields, 3 kHz to 300 GHz

American National Standards Institute (C95.3 – 1992), IEEE Recommended Practice for the Measurement of Potentially Hazardous Electromagnetic Fields – RF and Microwave

2. INTRODUCTION

2.1 DESCRIPTION

Your XG-100P provides full-spectrum multiband coverage:

- 136 to 174 MHz, VHF, 1 watt, 2 watts, 3 watts, 6 watts output
- 380 to 520 MHz, UHF-Low, UHF-High, 1 watt, 2 watts, 3 watts, 5 watts output
- 762 to 870 MHz, 700/800 bands, 0.5 watt, 1 watt, 2 watts, 3 watts output

The XG-100P has the following capabilities:

- Project 25 (P25) Conventional
- P25 Trunking
- Analog FM
- Advanced Encryption Standard, 256-bit (AES-256)
- Digital Encryption Standard Output Feedback (DES-OFB) Encryption
- Digital Encryption Standard Cipher Feedback (DES-CFB) Encryption
- Global Positioning System (GPS)
- Bluetooth®
- Over The Air Rekey (OTAR)
- Preemptive Priority Scanning
- Global Common Key References (CKR)
- Smart Battery status and reporting
- Feature Management (Using Radio Personality Manager [RPM] R6A or later)

For optional accessories, refer to 7.2. Additional accessories may have been added since publication of this manual; contact Harris for more information.

2.2 STORAGE GUIDELINES

Store your XG-100P and batteries in a clean, cool (not exceeding 86 °F [+30 °C]), dry, and ventilated storage area.

3. BASIC SETUP

3.1 ASSEMBLE THE RADIO



Only use a Harris charger approved for the battery chemistry. Injury could occur from improper charger use.



Do not over-tighten the antenna as damage could result.

1. Make sure batteries are charged per charger manual 10515-0372-4010 (supplied with the charger).
2. To attach optional belt clip, slide into groove in back of the radio above battery compartment.
3. Lift clip, if installed, and slide top of battery into top of battery compartment at the rear of the radio.
4. Press down on bottom side of battery until it snaps into place.
5. Radio may need to be set for battery type (refer to Section 5.13.6).

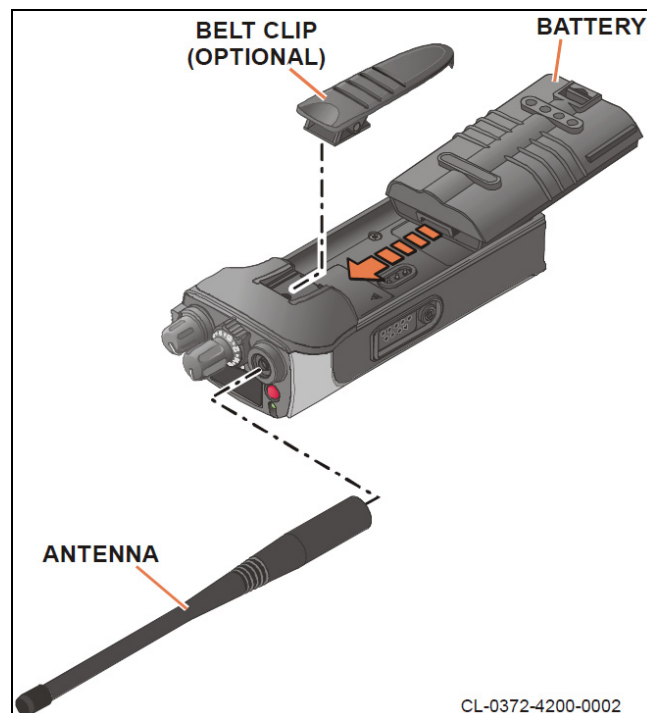

Figure 3-1: Radio Assembly

3.2 REMOVING THE BATTERY

To remove, press and hold tab, lift battery clip, then pull battery up and out of the radio.

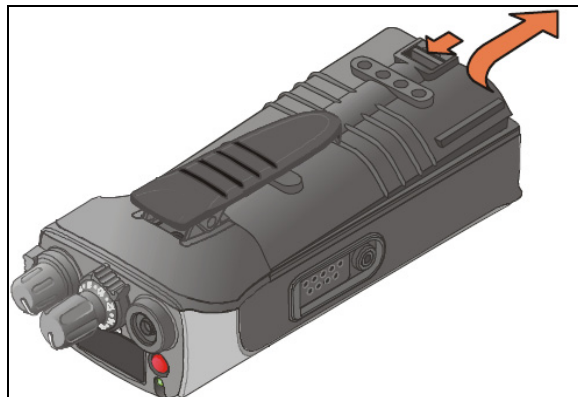

Figure 3-2: Remove the Battery

3.3 REMOVING THE OPTION BELT CLIP

Remove the battery before removing the belt clip. To remove the belt clip, press and hold the tab towards the top of the battery compartment and slide the belt clip out of the groove in the back of the radio.

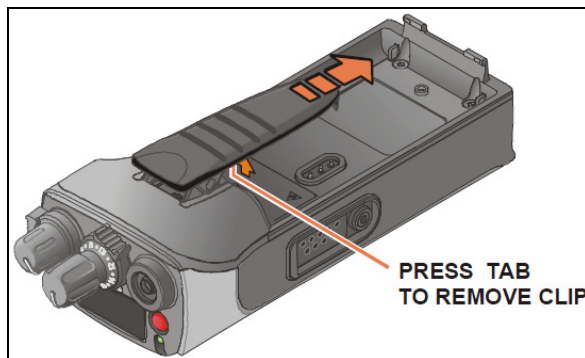

Figure 3-3: Remove Belt Clip

4. BASIC OPERATION

4.1 XG-100P CONTROLS

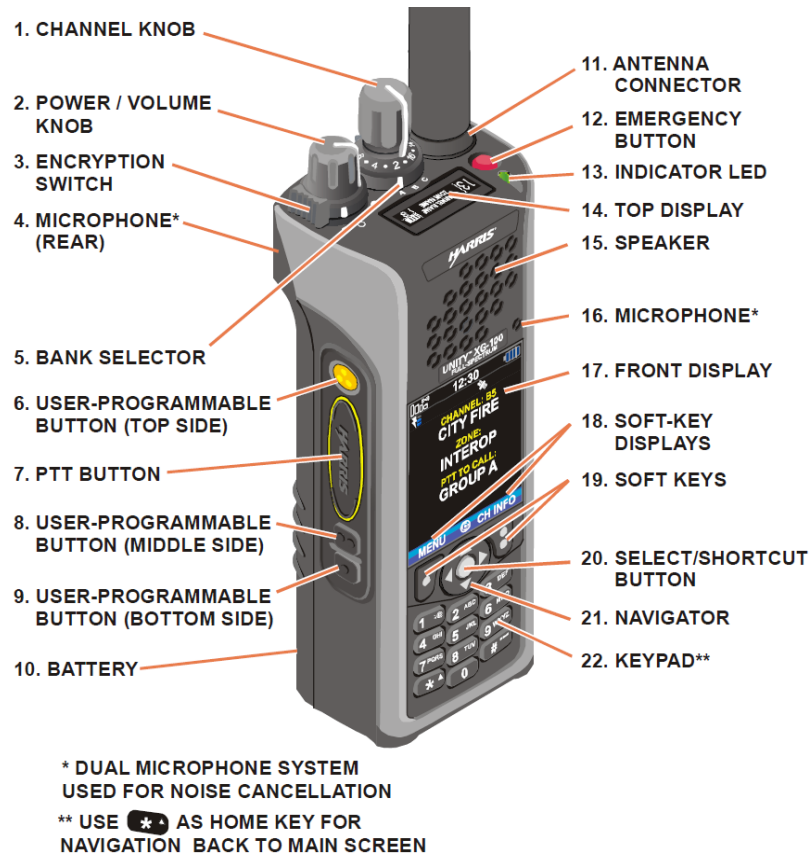

Figure 4-1: XG-100P Controls

Table 4-1: XG-100P Controls, Indicators, and Connectors

KEY	CONTROL/INDICATOR	FUNCTION
1	Channel Knob	Used to select one of 16 channels.
2	Power/Volume Knob	Turn clockwise to power on radio and increase volume of audio heard in speaker.
3	Encryption Switch	Switches between encrypted and unencrypted operation. Ø – Secure (PVT Enabled) O – Clear (PVT Disabled)
4	Microphone (Rear)	When noise cancellation is enabled (Section 4.8), the rear microphone is used with the front to form a dual microphone system that is used for noise cancellation. Noise cancellation improves the quality of transmitted voice. When noise cancellation is disabled, only the front microphone is used.
5	Bank Selector	Used to select one of three banks: A, B, or C (Section 4.9).
6	User-Programmable Button (Top Side)	Used to select a commonly used function as an alternative to navigating menus. This is configured via programming using RPM.
7	Push-To-Talk (PTT) Button	Press to transmit. Make sure Push-To-Talk (PTT) is enabled (Section 5.13.1)
8	User-Programmable Button (Middle Side)	Used to select a commonly used function as an alternative to navigating menus. This is configured via programming using RPM.

KEY	CONTROL/INDICATOR	FUNCTION
9	User-Programmable Button (Bottom Side)	Used to select a commonly used function as an alternative to navigating menus. This is configured via programming using RPM.
10	Battery	Battery - Refer to Section 3 for battery connection and removal.
11	Antenna Connector	Provides Subminiature version A (SMA) antenna connector.
12	Emergency Button	Used to place radio in emergency mode (see Section 4.20). This button can be disabled by setting to unassigned via programming using RPM.
13	Indicator Light Emitting Diode (LED)	Indicates radio status. Red = actively transmitting. Green = actively receiving. Orange = actively transmitting encrypted.
14	Top Display	Top display shows summary of status such as channel, battery, scanning, and emergency status. This can be configured for viewing from the front or rear of the radio (Section 5.13.2).
15	Speaker	Radio speaker which can be muted (Section 5.13.1). Volume can be adjusted using the Power/Volume knob.
16	Microphone	When noise cancellation is enabled (Section 4.8), the front microphone is used with rear microphone to form a dual microphone system that improves the quality of transmitted voice. When noise cancellation is disabled, only the front microphone is used.
17	Front Display	Front display shows complete status and radio menus.
18	Soft-Key Displays	These are displays of menus that are accessed by pressing a soft-key directly below text (Section 4.5).
19	Soft Keys	Accesses menus labeled in text directly above button (Section 4.5).
20	Select/Shortcut Button	Used to select menu highlighted by navigator. Also used to access the shortcut menu from the main screen (Section 5.14).
21	Navigator	Provides up, down, left, and right menu navigation. Also used for select and shortcut menu navigation.
22	Keypad	Used to enter text or numbers, and to quickly access menus. You can use as a home key to quickly navigate back to the main screen.

4.2 TOP DISPLAY

The top display shows a summary of status, such as channel number, channel short name, zone/system short name, battery, scanning, and emergency mode. The display can be configured for viewing from the front or rear of the radio (see Section 5.13.2). Channel short name and zone/system short name are programmed in RPM.



Figure 4-2: Top Display

4.3 MAIN DISPLAY

The main display appears after power up or after exiting from the menus. The XG-100P also contains an icon glossary in the Utility Menu (see Section 5.17).

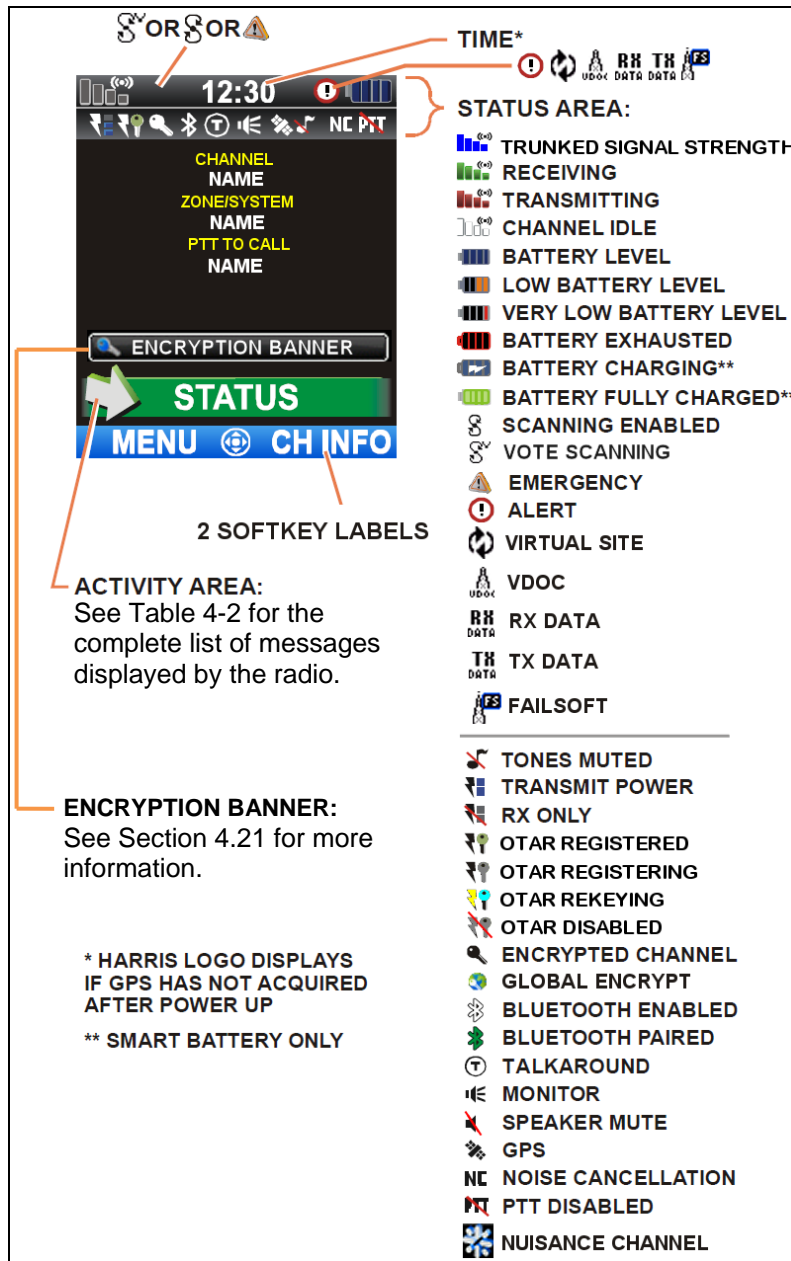

Figure 4-3: Main Display

4.4 STATUS MESSAGES

During radio operation, various radio Status Messages may be displayed. The messages are described below.

Table 4-2: Status Messages

MESSAGE	DESCRIPTION
PTT DENIED	P25 Trunked only - Indicates the radio or talkgroup is not authorized to operate on the selected system and/or talkgroup.
CALL QUEUED	P25 Trunked only - Indicates the system has placed the call in a request queue.
SYSTEM BUSY	P25 Trunked only - Indicates the system is busy, no channels are currently available, the queue is full, or an individual call is being attempted to a radio that is currently transmitting.
SCANNING	Indicates the radio is scanning.
TX EMERGENCY	P25 modes only - Indicates an emergency call is being transmitted.
RX EMERGENCY	P25 modes only - Indicates an emergency call is being received. If programmed via RPM, radio will display the unit name or unit ID.
WIDE AREA SCAN	P25 Trunked only - Indicates the radio has entered the Wide Area Scan mode to search for a new system (if enabled through programming).
INVALID TALKGROUP	P25 Trunked only - Indicates the current talkgroup is not valid for the current system. This could happen if the site denies registration due to an unrecognized talkgroup ID.
REGISTERING	P25 Trunked only - Displayed when the radio is performing a registration/affiliation on a P25 trunking site.
CTRL CHANNEL SCAN	P25 Trunked only - Indicates the control channel is lost and the radio has entered the Control Channel Scan mode to search for the control channel (usually out of range indication).
BAND SCANNING	P25 Trunked only - This message is only displayed if the P25T system is configured for "EnhancedCC" mode of operation. When the radio cannot find a Control Channel in either the trunked frequency set or the list of discovered adjacencies, the radio is able to perform a full spectrum frequency scan to find a new Control Channel.

4.5 MENU NAVIGATION

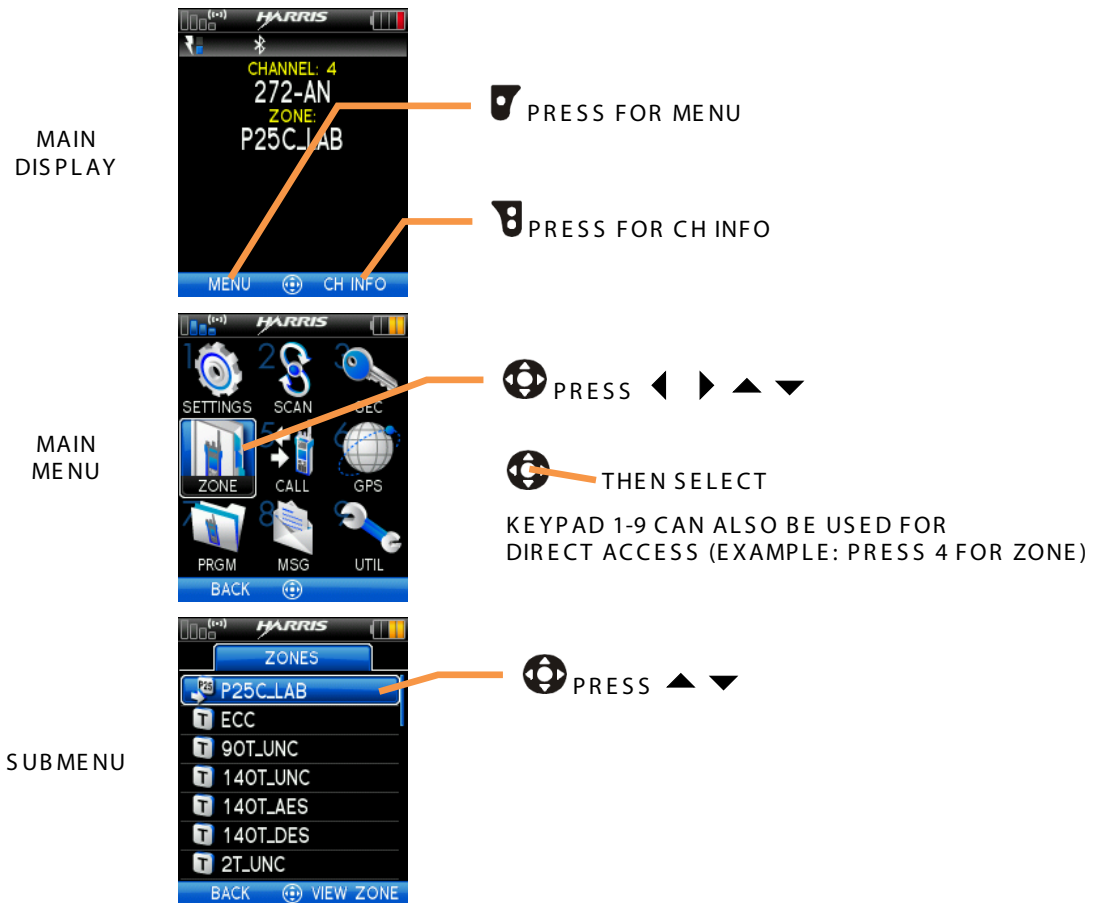



4.6 BEFORE FIRST USE

Make sure XG-100P has:

- Fully charged battery
- Antenna attached
- Mission plan and radio programmed using the RPM
- Encryption keys loaded if using encrypted channels
- Mission plan activated

4.7 POWER ON AND SET VOLUME

The power switch and volume control are within the same control.

1. Turn  clockwise to power on XG-100P.
2. Set  to desired volume level.

4.8 NOISE CANCELLATION

The XG-100P features Harris' proprietary noise suppression capability to provide clear and crisp voice quality in high-noise environments for use in any mode, including both analog and digital communications.

The XG-100P has two microphones; one located on the front (primary) and one on the rear (secondary). The primary microphone operates in exactly the same manner as a normal radio and is the one you talk into. The secondary microphone is used to pick up the surrounding noise when noise cancellation is turned on.

In the case where noise cancellation is enabled and a speaker microphone is attached to the XG-100P, talk into the speaker microphone. In this mode, XG-100P front microphone is used to pick up the surrounding noise, and the rear microphone is unused. See Section 4.8.4 for more information.

If the secondary microphone is blocked, the XG-100P operates as though noise cancellation is turned off.

4.8.1 Enable Noise Cancellation and Voice Assist



NOTE

Enabling Voice Assist reduces audio distortion for high-level audio inputs.

To enable Noise Cancellation and Voice Assist:

1. Select **SETTINGS** → **AUDIO SETTINGS**.
2. Highlight and enable **NOISE CANCELLATION** using .
3. Highlight and enable **VOICE ASSIST** using .



Figure 4-4: Enable Noise Cancellation and Voice Assist

Refer to Section 5.13.1 for more information on the Audio Settings menu.

4.8.2 Using Noise Cancellation

When using the noise cancellation feature, observe the following:

- Verify the **VOICE ASSIST** and **NOISE CANCELLATION** options are enabled (see Section 4.8.1).
- Talk within two (2) inches of primary microphone (see Figure 4-5).
- Speak clearly, loudly, and with authority.
- If possible, face the noise source when talking into the radio (see Figure 4-5).
- Ensure the primary and secondary microphones are not covered. See Section 4.8.4 for more information on the primary and secondary microphones.
- In very noisy environments, it is o.k. to yell into the radio. The radio can handle very loud input levels.

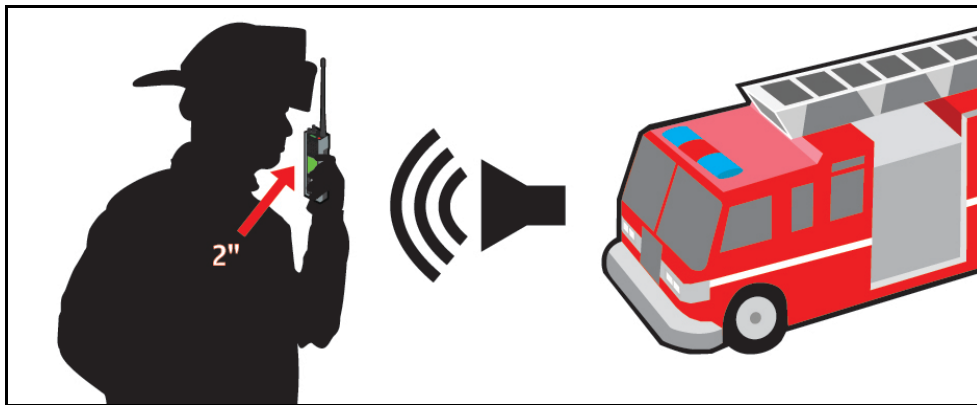

Figure 4-5: Using the Noise Cancellation Feature

4.8.3 The Effect of Distance from the Microphone

Unlike a normal microphone system, noise cancellation makes the level of your voice diminish quickly as you move away from the radio. In essence, the radio starts to see your voice as surrounding noise. Whereas, you may be comfortable speaking up to a foot away from the front of a normal radio, noise cancellation requires that you keep it close.

4.8.4 Primary versus Secondary Microphone

4.8.4.1 Without a Speaker Microphone Attached

The primary microphone is located on the front of the radio and the secondary is on the back of the radio. See Figure 4-6 for the location of these microphones.



Figure 4-6: Without a Speaker Microphone Attached

4.8.4.2 With a Speaker Microphone Attached

When a speaker microphone is attached, the radio electronically switches over to use the radio's front microphone as secondary. The microphone on the attached speaker microphone becomes primary (see Figure 4-7).



Figure 4-7: With a Speaker Microphone Attached

4.9 SELECT CHANNEL AND BANK

The XG-100P can be programmed with up to 1250 channels, with 16 channels in each of the three banks.



1000 channels per zone/system.

- **Bank A** - Channel A1 - A16
- **Bank B** - Channel B1 - B16
- **Bank C** - Channel C1 - C16

Use  to set channel 1 – 16.

Use  to set bank. The selected bank is indicated on the display.



If your system has more than 48 channels, the **SEL CHAN/GRP** option available from the shortcut menu, allows you to select a channel group with channels 49-96, 97-144, etc. See Section 5.14.4 for more information.

4.10 TURN ENCRYPTION ON OR OFF

Use  to set encryption: Ø – Secure (PVT Enabled)

O – Clear (PVT Disabled)

- Key appears on the display when encryption is enabled. The channel must also be programmed to be encrypted.
- When encryption is turned on and you use any channel not configured for encryption, the radio allows PTT. The signal is transmitted unencrypted.
- Systems configured for Global Encryption display a Global Encryption icon instead of key icon (Section 5.8) if Global Encryption is enabled.

4.11 USER INTERFACE PRIVILEGE LEVEL

Depending on radio programming, some of the menu options described in this manual may not be available. The following table details the menus available for the different levels of User Interface Privilege:

Figure 4-8: User Interface Privilege

	FULL ACCESS	LIMITED ACCESS	RESTRICTED ACCESS
Audio Settings	✓		
GPS Settings	✓		
Clock Settings	✓		
Battery Setting	✓		
Bluetooth Settings	✓	✓	
View/Edit Softkey (System List)	✓	✓	✓
View/Edit (Zone List)	✓	✓	✓
Zeroize	✓		
Keypad Changeover	✓	✓	
Global Encryption	✓	✓	
Global Key	✓		
Program Menu only in Active Mission Plan	✓	✓	
Self-test on Utility Menu	✓	✓	
TCXO Tuning on Utility Menu	✓		
P25 Test Selection on Utility Menu	✓		

4.12 SELECT ZONE/SYSTEM USING MENUS

A zone/system is a group of channels that can be programmed by agency or geographical region. For example, a zone/system could be for fire, police, New York, Los Angeles, etc.

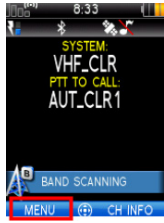

1. At main display, use to select **MENU**.

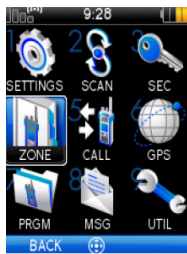

2. Use to highlight and select **ZONE**, or press .

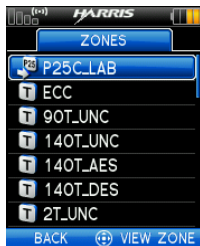

A mission plan could have up to 512 zones/systems, independent of banks or channels.

3. Use to view zone/system. indicates the active zone/system.
4. Use to highlight and select zone/system.

If **VIEW ZONE** is selected, a screen appears allowing you to view the channels in the zone/system.

5. Use to scroll through the zones/systems.
6. Use to select highlighted zone/system.

New zone/system appears.

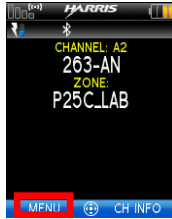

4.13 USE TALKAROUND TO BYPASS REPEATER (CONVENTIONAL ONLY)

You can bypass the repeater system to communicate directly with other radios on your current channel's receive frequency. This is useful if you are out of range of a repeater or if a repeater is busy. You will need to be in range of the other radio.

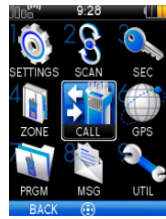

1. At main display, use  to select **MENU**.



2. Use  to highlight and select **CALL**, or press .

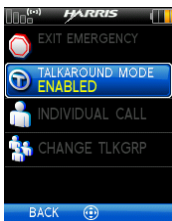

3. Use  to change **TALKAROUND MODE** to **ENABLED**.



4. The Talkaround icon appears. Calls are now made on the receive frequency until you disable talkaround mode via the **CALL** menu. Power cycling the radio does not disable talkaround.

4.14 INDIVIDUAL CALLS

An individual call is used to make a call to one radio as opposed to a group of radios. An individual call can only be made on a digital channel.

4.14.1 Transmit an Individual Call



1. At main display, use to select **MENU**.

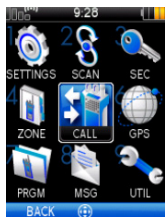

2. Use to highlight and select **CALL**, or press **5 JKL**.

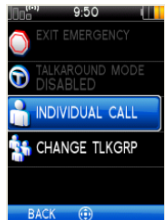

3. Use to highlight and select **INDIVIDUAL CALL**.

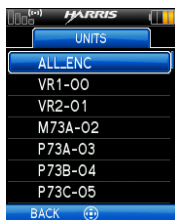

4. Use to highlight and select the unit to call.



5. Press PTT to make the call.
6. To end call, use to select **END CALL**.

4.14.2 Receiving an Individual Call



1. When receiving an Individual Call, the radio displays the calling radio's name or Unit ID.
2. Press the PTT button to respond. The amount of time the radio will remain in the Individual Call mode with no activity is programmable via RPM.



3. The radio rings and indicates a missed call if you do not respond to an incoming Individual Call. The ring sounds continuously until you press PTT, select the **CLR MISSED** softkey, or power cycle radio.



4. If your system is configured for Acknowledged Individual Call, you have the option to **REJECT CALL** using .

4.15 GROUP CALLS

4.15.1 Transmit a Group Call

A talkgroup is a group of radios that you want to have private conversations with. These groups can be divided into areas such as state, region, county, or large special events. A talkgroup call can only be made on digital channels.



1. At main display, use to select **MENU**.

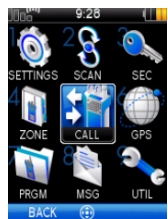

2. Use to highlight and select **CALL**, or press .

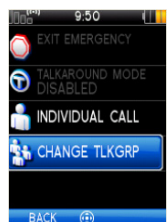

3. Use to highlight and select **CHANGE TLKGRP**.



4. Use to highlight and select the talkgroup. After selecting the new talkgroup, the radio returns to the main screen.
5. Press PTT to make the call.

4.15.2 Receive a Group Call

When receiving a group call, the radio display toggles between the Unit Name and the Group Name of the transmitting radio. Note that if either of those names is not programmed, the corresponding ID number is displayed.



Figure 4-9: Unit ID

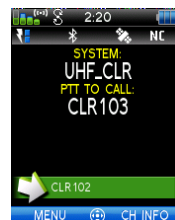

Figure 4-10: Group ID

4.16 START SCAN

This procedure assumes that the scan list has been added and is not in active scan. Refer to Section 5.15 for scan setup or Section 4.17 for stopping scan. Refer to Section 5.15.1.1, Section 5.15.1.2, and Section 5.15.1.3 for home and priority channel descriptions.



NOTE

For shortcut method of starting scan, refer to Section 5.14.1.



1. At main display, use to select **MENU**.



2. Use to highlight and select **SCAN**, or press .

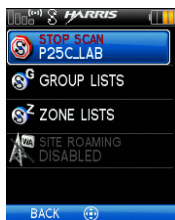

3. Use to highlight and select **START SCAN**. The green **START SCAN** text changes to red **STOP SCAN**.
4. Use to select **BACK** and exit scan menu.

4.17 STOP SCAN

Perform the following to stop an active scan.



NOTE

For shortcut method of stopping scan, refer to Section 5.14.1.



1. At main display, use to select **MENU**.



- Use to highlight and select **SCAN**, or press .

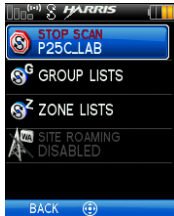

- Use to highlight and select **STOP SCAN**.
- Use to select **BACK** and exit scan menu.

4.18 NUISANCE DELETE

A channel can temporarily be deleted from the scan list. Priority 1 and priority 2 channels cannot be nuisance deleted.

You can also perform a nuisance delete from the Shortcut Menu (Section 5.14).



NOTE

Nuisance delete can only be performed on the active scan list.



- At main display, use to select **MENU**.

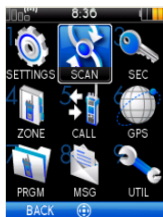

- Use to highlight and select **SCAN**, or press .

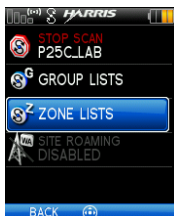

- Use to highlight and select **ZONE LISTS**.

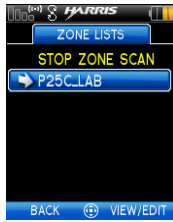

4. Use to highlight the scan list. indicates the active scan list.
5. Use to select **VIEW/EDIT**.

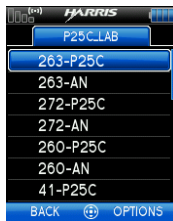

6. Use to highlight the channel.
7. Use to select **OPTIONS**.

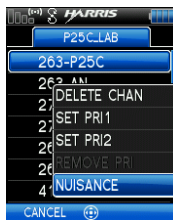

8. Use to highlight and select **NUISANCE**.

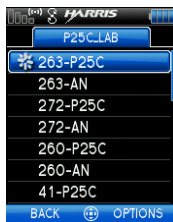

The icon appears next to the channel and it will not be scanned.



9. Use to highlight and select **ADD BACK** to add channel back to scan list. If you do not add the channel back to the list, the channel will return to scan list when you cycle radio power or activate a mission plan.
10. Use to select **BACK** and exit the channel list.
11. Use to select **BACK** and exit Zone or Group lists display.

4.19 VIEW GPS INFORMATION

You can use the internal Global Positioning System (GPS) receiver to view your position and satellite information. Remember, GPS requires an unobstructed view of the sky and the signal is greatly diminished inside buildings, tunnels, heavily forested areas, etc. GPS may not work at all under some materials, especially metal.

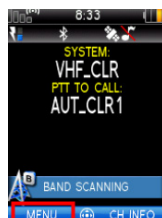

1. At main display, use to select **MENU**.



- Use to highlight and select **GPS**, or press .

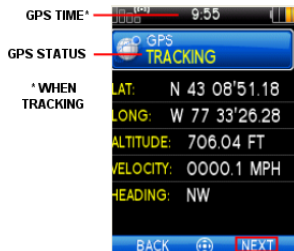

You can observe GPS status:

- **GPS DISABLED** - GPS is disabled via programming.
- **GPS TRACKING** - GPS has acquired satellite signal. GPS time appears on top of display.
- **GPS SEARCHING** - GPS has not acquired. Harris logo appears on top of display if GPS has not tracked after last power up of the radio.
- **LAST KNOWN POS** - Radio was tracking and then lost GPS signal. The information displayed is from the last known position.



- Use to select **NEXT** to view satellite information.
- Use to select **BACK** and exit GPS screens.

4.20 EMERGENCY OPERATION

The XG-100P can be programmed to enable emergency mode. Unit name displays on dispatcher console if an emergency signal is received from another XG-100P on a digital channel.

4.20.1 Declaring an Emergency Call

- Press and hold the button on top of the radio. The length of time you need to hold the button is configured in RPM.

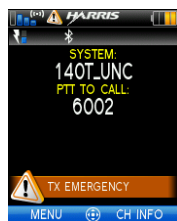

For digital channels, the radio transmits the talkgroup or radio ID to the dispatch console or receiving radio.

The radio will go through transmit and receive cycles if configured.

Speak into the microphone while the radio is transmitting or press PTT to talk.

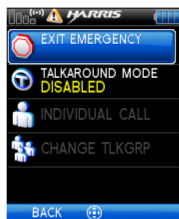

- To exit emergency, power cycle the radio or select **EXIT EMERGENCY** from the CALL menu.

4.20.2 Receiving an Emergency Call

When receiving an Emergency Call, an alert beep sounds (if tones are enabled) and an emergency indication is displayed.



Depending on options selected in RPM, the unit ID or unit name may be displayed.

While the emergency display is active, press **PTT** to respond to the emergency caller.

4.21 ENCRYPTION BAR

The encryption bar is shown in Table 4-3. Encryption keys must be loaded (Section 5.2 or Section 5.3) for these indications to be displayed.

Table 4-3: Encryption Bar Indications

DISPLAY	DESCRIPTION
	This is an example of a key name of an AES and a DES key being transmitted or received.
	Encryption key assigned to channel was not found.
	This message appears on receive radios. Encryption key assigned to channel was not used on transmitting radio.

4.22 OTAR SCREENS

The Over The Air Rekey (OTAR) screen is shown in Table 4-4. OTAR must be enabled (see Section 5.10).

Table 4-4: OTAR Display Messages

DISPLAY	DESCRIPTION
	This is the main screen showing the OTAR status (receiving/transmitting, registering, and rekeying).

5. ADVANCED OPERATIONS

5.1 CREATE KEYS

Refer to the following documentation for advanced programming and setup instructions:

- Motorola® KVL 3000 Plus Key Variable Loader (KVL) User's Guide
- Harris OTAR Overview Manual - MM-008069-001
- Network Key Manager Installation and Configuration Manual - MM-008070-001
- Harris UAS Key Management Application Manual - MM-008068-001
- Harris Key Manager Key Admin Overview and Operation Manual - MM1000019423
- Harris Key Manager Key Loader Overview and Operation Manual - MM1000019424



If using Key Manager to create and load keys, ensure that you have version R5A or later installed. Versions prior to R5A do not support the Unity portable radio.

5.1.1 Create Keys using Harris Key Admin

Harris Key Admin is part of the Harris Key Manager and is for use by the Crypto Officer (CO). The CO creates a Master Set of keys from which a Distribution Set is produced. Using the Key Admin software, the CO can save keys onto Distribution Security Devices to transport these keys to technicians for use in radios.

1. Connect the Master Security Device to the PC.
2. Select **Start → Programs → Harris Key Manager → Harris Key Admin**.
3. Select **New Master Set** or **Load Existing Set**. Refer to the Key Admin online help for more information on creating keys.
4. When finished, create a Distribution Security Device. A Distribution Security Device is used with the Key Loader to load key sets into the radio and cannot be edited. Refer to the Key Admin online help for more information on creating the Distribution Security Device.

5.1.2 Create Key in the KVL 3000 Plus

You can generate a single Type-3 key in the KVL 3000 Plus key loading device:

1. Turn on the KVL 3000 Plus.
2. Select **KEYS**.
3. Select **NEW**.
4. Enter a number between **00001** and **04095** or between **61440** and **65535** at Common Key References (CKR) prompt. The number must be unique on the KVL 3000 Plus.
5. Choose **DES-OFB** or **AES-256** as the algorithm.
6. Select **ACCEPT**.
7. Enter Key Identification (KID) from **0001** to **FFFF**. The number must be different for each key of a particular algorithm in the KVL 3000 Plus.



NOTE

The XG-100 does not support KID 0000. Attempting to load a key with KID 0000 from the KVL will result in the failure **UNKNOWN ERRICHECK TARGETALGORITHM!** displayed on the KVL. KID 0000 is reserved for the Suppressed Key feature.

8. Enter a hexadecimal number as the Key value. DES-OFB keys are 16 digits while AES keys are 64 digits (32 bytes [256 bits]). Odd parity checks are made between every two digits for DES-OFB keys. Parity checks are not made for AES-256 keys.
9. KVL 3000 Plus will display **SLOT FILLED**, press **ENTER**.
10. A message is displayed when complete: **KEY WAS CREATED SUCCESSFULLY**.
11. Refer to Section 5.2 for loading a key into the radio.

5.1.3 Create Keygroup in the KVL 3000 Plus

You can generate a group of Type-3 keys in the KVL 3000 Plus:

1. Turn on the KVL 3000 Plus.
2. Select **Esc**.
3. Select **GROUPS**.
4. Select **NEW**.
5. Enter a Group Name (up to seven characters).
6. Select CKRs from the programmed list until all desired CKRs are selected.
7. Select **DONE**. Refer to Section 5.2 for loading a keyset into the radio.

5.2 LOAD KEYS

5.2.1 Load UKEKs with UKEK Loader and RPM (for OTAR-Enabled Systems)

UKEKs are loaded into Harris OTAR radios using the UKEK Loader application. UKEK Loader is a part of Key Manager.

To load encryption keys:

1. Obtain the UKEK file and Storage Location Number (SLN) Binding Report information from the Crypto Officer (CO).



NOTE

Both AES and DES UKEKs can be contained within the same UKEK file.

2. If not already on, power-up the PC that has RPM and the UKEK Loader applications installed on it, and start Windows.
3. Connect the radio to the PC using programming cable 12082-0410-A1.



NOTE

The Unity drivers must be installed before UKEKs can be loaded into the radio. The Unity drivers may be found on the Key Loader CD (“unity setup.exe”) or on the Key Admin CD (“unity setup.exe”).

4. Load the UKEK file from the Crypto Officer onto the PC.
5. Run the RPM application and setup the radio's personality according the SLN Binding Report information.
6. Setup the talk groups and the SLN mappings (Talk Group ID to SLN). This includes mapping SLNs to the "System" keys (PSTN, All Call, etc.).
7. Select **Options** → **P25 OTAR Options** and set the following:
 - a. The OTAR Message Number Period (MNP) as defined by the System Administrator.
 - b. The radio's Individual RSI (from the SLN Bindings Report).
 - c. The KMF's RSI (from the SLN Bindings Report).
8. Select **Radio** → **Program** or click on the **Program** icon and write the personality to the radio.
9. Run the UKEK Loader application.
10. Open the UKEK file loaded in step 4.
11. Select the Target Device type (Auto-Detect is preferred) and click the **Load** button.
12. When prompted, enter your user name and password and click **OK**.

The UKEK Loader reads the target device's identifying information, retrieves a UKEK of the proper algorithm type from the UKEK file, and downloads the UKEK to the target device at the proper SLN and keyset with the proper key ID.
13. Click the **Finish** button to exit the Key Loader application. New UKEKs have are loaded and the radio is now ready to accept TEKs via OTAR with the trunked radio network.

5.2.2 Load Keys using Harris Key Loader

Harris Key Loader is part of Harris Key Manager and can be used by the Crypto Officer or Technician to load the keys into the Unity portable radio.

Refer to the Harris Key Loader online help if additional information is required when performing this procedure:

1. Connect the Distribution Security Device to the PC.
2. Connect the radio to the PC using the 12082-0410-A1 programming cable.
3. Power on the radio, if not already.
4. Select **Start** → **Programs** → **Harris Key Manager** → **Harris Key Loader**.
5. At the Key Loader Welcome screen, click **Next**.
6. Enter the User Password for your Distribution Security Device and click **Authenticate**.
7. Click **Next** and click **Next** again.
8. Wait while the Key Loader reads the Distribution Set and click **Next**.
9. Select **USB** from the drop-down and click **Next**.

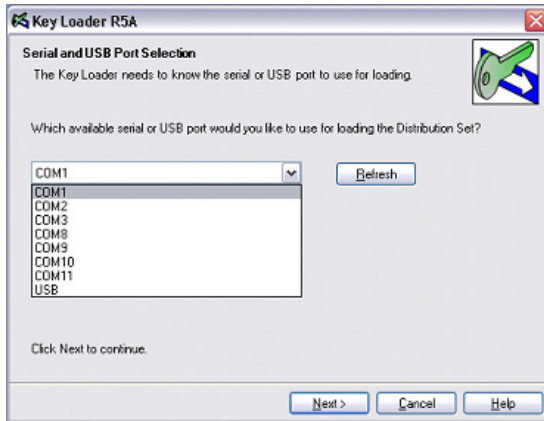

10. Select the Unity radio from the drop-down and click **Load**.

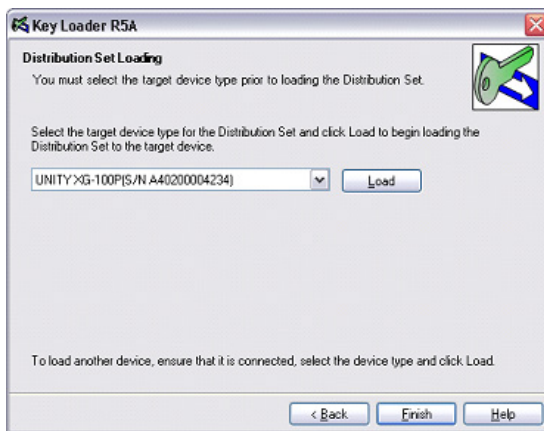

11. Click **Finish**.

5.2.3 Load Keys using Motorola KVL 3000 Plus

Type 3 Digital Encryption Standard Output Feedback (DES-OFB) and Advanced Encryption Standard, 256-bit (AES-256), encryption methods are supported. The Type 3 Encryption keys are loaded via a Motorola KVL 3000 Plus device using Telecommunications Industry Association (TIA)/Project 25 (P25) key fill device protocol. Make sure that valid keys have been created and stored in the KVL 3000 Plus before proceeding.

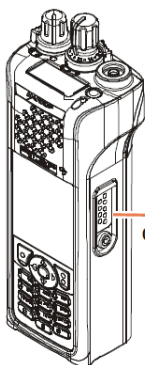

SIDE CONNECTOR

1. Power on KVL 3000 Plus.
2. Connect KVL 3000 Plus to side connector using a 12082-0400-A1 cable.

NOTE: Once the KVL 3000 Plus is connected, a keyset is established whether the keys are loaded or not. You will need to zeroize to bring the XG-100P to a fully zeroized state (Section 5.4).



- The key fill in progress screen will be displayed and the radio can accept keys from the KVL.

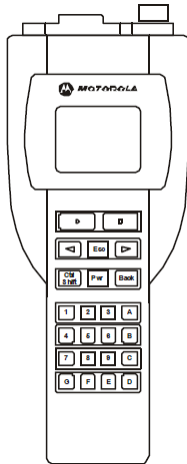

At the KVL 3000 Plus:

- Select **TARGET**.
- Select **LOAD**.
- Select **KEY**.
- Using ◀ or ▶, select:
 - DES-OFB key
 - AES-256 key
- Press **LOAD**.
- Verify that the KVL 3000 Plus screen displays **LOADED SUCCESSFULLY OK**.
- Select **OK** on the KVL 3000 Plus.
- Repeat for additional keys.
- Remove the KVL 3000 Plus cable from the radio.

5.3 LOAD KEYGROUPS

Make sure that valid keygroups have been created and stored in the KVL 3000 Plus before proceeding.

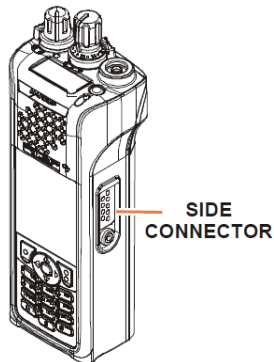

- Power on KVL 3000 Plus.
- Connect KVL 3000 Plus to side connector using a 12082-0400-A1 cable.

NOTE: Once the KVL 3000 Plus is connected, a keyset is established whether the keys are loaded or not. You will need to zeroize to bring the XG-100P to a fully zeroized state (Section 5.4).



- The key fill in progress screen will be displayed and the radio can accept keys from the KVL

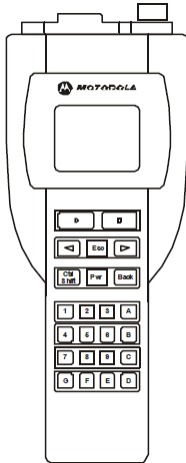

At the KVL 3000 Plus:

4. Select **TARGET**.
5. Select **LOAD**.
6. Select **GROUP**.
7. Using ◀ or ▶, select:
 - DES-OFB keygroups
 - AES-256 keygroups
8. Press **LOAD**.
9. Verify that the KVL 3000 Plus screen displays **LOADED SUCCESSFULLY OK**.
10. Select **OK** on the KVL 3000 Plus.
11. Repeat for additional groups.
12. Remove the KVL 3000 Plus cable from the radio.

5.4 ZEROIZE ALL FROM RADIO

It may be necessary to remove the keys because of compromise or expiration.

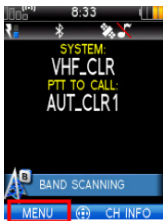

1. At main display, use for main menu.



2. Use to highlight and select **SECURITY**, or press .



3. Use to highlight and select **ZEROIZE KEYS**.
 4. Use to highlight and select **YES** if you want to remove the keys.
- NOTE:** This will also remove the keysets.
5. Use to select **OK**.

5.5 ZEROIZE KEYS USING KVL 3000 PLUS

Refer to the KVL 3000 Plus User's Guide for advanced instructions.

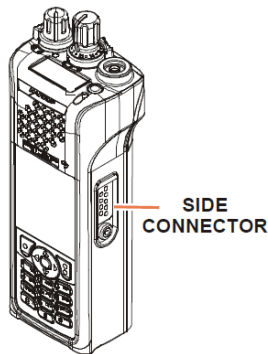

1. Power on KVL 3000 Plus.
2. Connect KVL 3000 Plus to side connector using a 12082-0400-A1 cable.

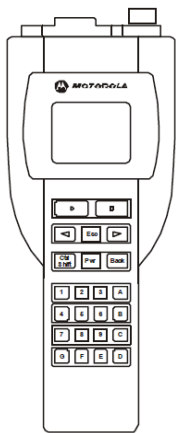

At the KVL 3000 Plus:

3. Select **TARGET**.
4. Select **ZERO**.
5. Select **KEY**.
6. Using ◀ or ▶, select the key to remove from the radio.
7. Press **ZERO**.
8. Verify that the KVL 3000 Plus screen displays **ZEROIZED SUCCESSFULLY OK**.
9. Select **OK** on the KVL 3000 Plus.
10. Repeat for additional keys.
11. Remove the KVL 3000 Plus cable from the radio.

NOTE: THE SELECTED KEY TO ZEROIZE IS DELETED FROM ALL KEYSETS.

5.6 ZEROIZE KEYGROUPS USING KVL 3000 PLUS

Refer to the Motorola KVL 3000 Plus User's Guide for advanced instructions.

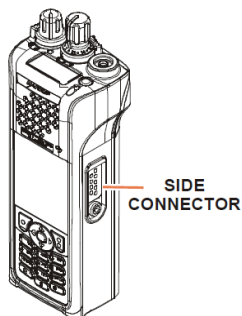

1. Power on KVL 3000 Plus.
2. Connect KVL 3000 Plus to side connector using a 12082-0400-A1 cable.

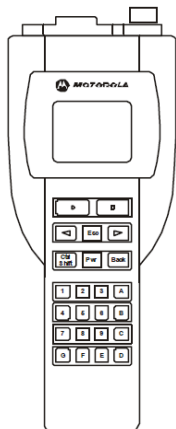

At the KVL 3000 Plus:

3. Select **TARGET**.
4. Select **ZERO**.
5. Select **GROUP**.
6. Using ◀ or ▶, select the key to remove from the radio.
7. Press **ZERO**.
8. Verify that the KVL 3000 Plus screen displays **ZEROIZED SUCCESSFULLY OK**.
9. Select **OK** on the KVL 3000 Plus.
10. Repeat for additional keys.
11. Remove the KVL 3000 Plus cable from the radio.

NOTE: THE SELECTED KEY TO ZEROIZE IS DELETED FROM ALL KEYSETS.

5.7 ZEROIZE ALL FROM KVL 3000 PLUS

Refer to the KVL 3000 Plus User's Guide for advanced programming and setup instructions.

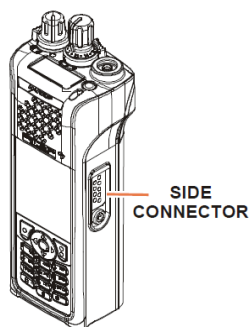

1. Power on KVL 3000 Plus.
2. Connect KVL 3000 Plus to side connector using a 12082-0400-A1 cable.

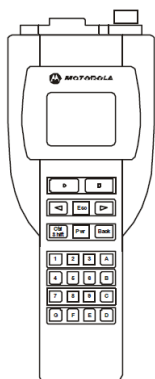

At the KVL 3000 Plus:

3. Select **TARGET**.
4. Select **ZERO**.
5. Select **ALL**.
6. Select **YES**.
7. Verify that the KVL 3000 Plus screen displays **ZEROIZED SUCCESSFULLY OK**.
8. Select **OK** on the KVL 3000 Plus.
9. Remove the KVL 3000 Plus cable from the radio.

NOTE: This removes all keys but the keysets remain. You will need to perform a zeroize from the radio to bring the XG-100P to a fully zeroized state (Section 5.4).

5.8 GLOBAL ENCRYPTION

Global Encryption is enabled when encryption keys are loaded on the radio and the selected Zone/System is encrypted. When Global Encryption is enabled on the radio, Global Key is used for all encrypted transmissions until:

- Global Encryption is disabled.
- A new mission fill is activated.
- The active keyset is changed.
- The system is changed.

Global Encryption behavior is available on all channels that support encrypted communications.



1. At main display, use for main menu.

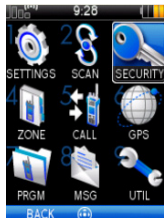

2. Use to highlight and select **SECURITY**, or press .

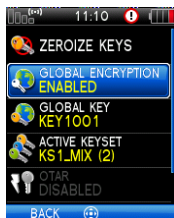

3. Use to change **GLOBAL ENCRYPTION** to **ENABLED**.

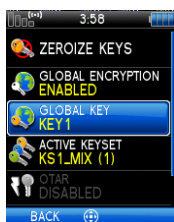

4. Use to highlight and select **GLOBAL KEY**.

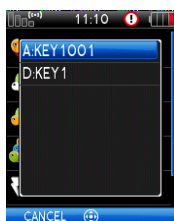

5. Use to highlight and select the global key.
6. The numbered keys are assigned in RPM.



7. The global key icon is displayed on the main display.

5.9 SELECT KEYSSET

1. At main display, use for main menu.

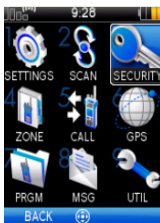

2. Use to highlight and select **SECURITY**, or press .

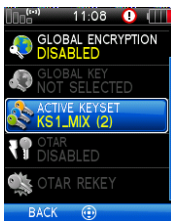

3. Use to highlight and select **ACTIVE KEYSSET** to toggle to the inactive keyset.
4. Select Home Key or repeatedly use to exit menus.

5.10 OTAR CONFIGURATION

OTAR is the over the air rekeying from a KMF and must be enabled for the digital only channel using RPM. For OTAR operation, the appropriate KEKs must be loaded into the radio using the Harris UKEK Loader or a KVL 3000.

The KMF Configuration must include the RSI of the KMF and the appropriate Message Number Period.

1. At main display, use for main menu.

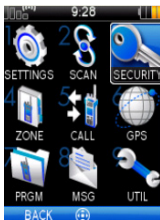

2. Use to highlight and select **SECURITY**, or press .
3. Use to change **OTAR** to **ENABLED** or **DISABLED**.
4. Use to select **OTAR REKEY** to request that the KMF updates the keys in the radio.
5. Select Home Key or repeatedly use to exit menus.

5.11 ACTIVATE/VIEW MISSION PLAN

Mission plans contain radio programming information such as frequencies, channels, stations, and talk groups. Up to 10 different mission plans can be stored in the radio, but only one can be activated at a time.

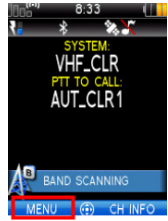

1. At main display, use for main menu.

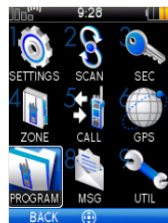

2. Use to highlight and select **PROGRAM**, or press .

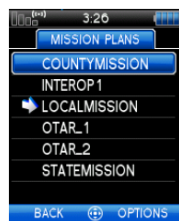

3. Use to highlight and select mission plan. indicates the active mission plan.

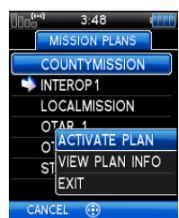

4. Use to select **OPTIONS**.
5. Use to highlight and select:
 - **ACTIVATE PLAN** - to activate the highlighted plan.
 - **VIEW PLAN INFO** - to view mission plan information.

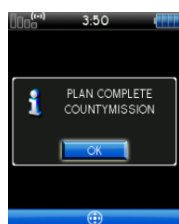

If plan is activated, radio displays series of screens indicating status, ending with a **PLAN COMPLETE** followed by name of plan.

6. Use to select **OK**.

NOTE: You cannot activate a plan when the radio is transmitting an emergency.

A **MISSION PLAN FAILED** message may be displayed for errors such as invalid syntax in the fill or some other invalid parameter.



7. If a plan is being viewed, radio displays the plan's filename and file size. Plan information appears if field was filled out in RPM.
8. Use to select **BACK**.
9. Select Home Key or repeatedly use to exit menus.

5.12 CH INFO MENU

The Channel Information (CH INFO) menu displays information about the currently selected channel. The information displayed varies between conventional and trunked systems.



Conventional

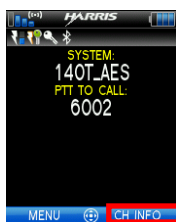

Trunked

1. At main display, use for channel information menu.

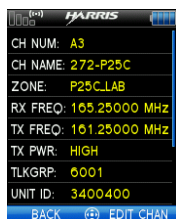

Conventional



Trunked

2. Use to scroll through the programmed channel settings.

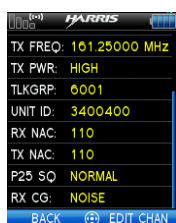

Conventional

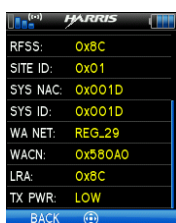

Trunked

3. Additional settings can be found by scrolling down.

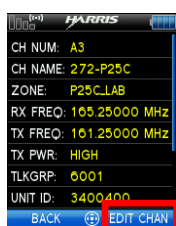

CONVENTIONAL ONLY:

4. Use to select **EDIT CHAN**.

5. Enter password.

NOTE: Password remains active until power cycle.

Refer to Section 6.2.

5.13 SETTINGS MENU

The settings menu allows you to change global radio settings such as audio, display, GPS, Bluetooth, clock, and battery settings.

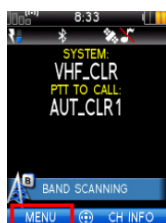

1. At main display, use for main menu.

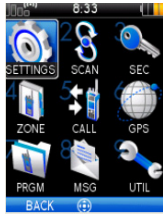

- Use to highlight and select **SETTINGS**, or press .



- Use to highlight setting.
- Additional settings can be found by scrolling down.

Refer to the Sections 5.13.1 through 5.13.6 for more information on the available settings.

5.13.1 Audio Settings

Set audio settings such as speaker mute, noise cancellation, PTT, and tones.

- Enter the Settings Menu.



- Use to highlight and select **AUDIO SETTINGS**.

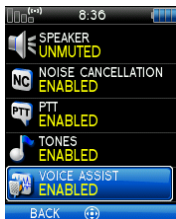

- Use to select and change settings as desired:
 - SPEAKER** - Speaker audio can be muted or unmuted.
 - NOISE CANCELLATION** - Enable or disable noise cancellation. Noise cancellation reduces background noise during transmit.
 - PTT** - Enable or disable Push-To-Talk (PTT). Disable to prevent accidental keying, such as when radio is in holster or you are getting into a car.
 - TONES** - Enable or disable alert tones (Table 5-1).
 - VOICE ASSIST** – Enable or disable Voice Assist. Enabling Voice Assist reduces audio distortion for high level audio inputs.
- Use to exit menu.

Table 5-1: Alert Tones

TONE	DESCRIPTION	SOUND/DURATION
Ready To Talk Tone Unencrypted (Analog FM or P25 digital)	After a PTT is pressed, this control enables the radio to produce an audible indication (tone) for you to begin speaking into the microphone.	1000 Hz for 25 ms
Ready to Talk Tone Encrypted P25 digital	After a PTT is pressed, this control enables the radio to produce an audible indication (tone) for you to begin speaking into the microphone.	1200 Hz tone for 25 ms
PTT Denied	PTT not possible. Momentary tone is present: <ul style="list-style-type: none"> • Receive only • Key not found • PTT button disabled • Emergency button disabled • Emergency not supported for current channel • Clear transmit denied 	544 Hz tone for 75 ms
Maximum transmit duration expires	Maximum transmit duration is exceeded.	5 beeps and then a 544 Hz tone for 75 ms
Low Battery Alarm	Alarm sounds upon initial detection of low battery and every 30 seconds thereafter. Tone stops upon detection of a battery charging state.	Sequence of tones: <ul style="list-style-type: none"> • 937 Hz tone for 50 ms • Silence for 60 ms • 1300 Hz tone for 50 ms
Emergency Call Received	Radio is receiving an emergency call or priority call.	600 Hz tone for 250 ms and 1800 Hz tone for 250 ms
Out of Range	Radio fails to find a local control channel.	Programmable via RPM: <ul style="list-style-type: none"> • Disabled (no tone) • Slow (tone every 15s) • Medium (tone every 10s) • Fast (tone every 5s)

5.13.2 Display Settings

1. Enter Settings Menu.

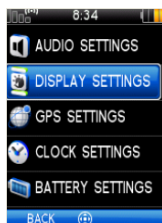

2. Use  to highlight and select **DISPLAY SETTINGS**.

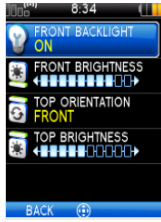

3. Use  to change settings as desired:
 - **FRONT BACKLIGHT** - Turn front display backlight on, off, or momentary.
 - **FRONT BRIGHTNESS** - Set brightness level of front display. A level of 0 has same effect as turning off backlight.
 - **TOP ORIENTATION** - Set orientation of top display to be viewed from radio **FRONT, BACK** or **AUTO**.
When **AUTO** is selected, the XG-100P changes top display to be viewed from back if an external microphone or speaker is attached. Otherwise, the display can be viewed from the front.
 - **TOP BRIGHTNESS** - Set brightness level of top display. A level of 0 turns off top display and indicator (TX/RX) LED.

4. Use  to exit the menu.

5.13.3 GPS Settings

1. Enter Settings Menu.



2. Use  to highlight and select **GPS SETTINGS**.



3. Use  to change settings as desired:
 - **GPS** - Enable or disable internal GPS.
 - **LINEAR UNITS** - Set unit of measurement of displayed linear units: **STATUTE, METRIC, or NAUTICAL**.
 - **ANGULAR UNITS** - Set unit of measurement of displayed angular units: **CARDINAL, DEGREES, or MILS**.
 - **POSITION FORMAT**- Set format of displayed position information: Latitude/Longitude Degrees Minutes Seconds (**LAT/LONG DMS**), **LAT/LONG DM**, Military Grid Reference System (**MGRS**), or Universal Transverse Mercator (**UTM**).

4. Use  to exit the menu.

5.13.4 Bluetooth

Bluetooth settings only appear if enabled in RPM.

1. Enter Settings Menu.



2. Use  to highlight and select **BLUETOOTH**.



3. Use  to set **ENABLED** to **YES**.

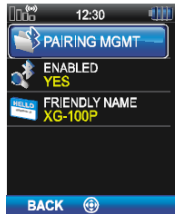

4. Use  to select **PAIRING MGMT**. This is used to pair the radio with another Bluetooth device.

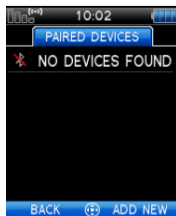

5. Make sure device being paired is powered on and has discovery mode enabled in order to pair with the XG-100P.

If no devices are found and Bluetooth is enabled, **ADD NEW** appears in the lower right corner. If devices are found, **OPTIONS** appears.

6. Use  to **ADD NEW** or **OPTIONS**.

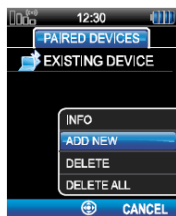

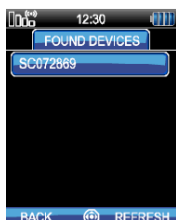

If **OPTIONS** was selected, the options menu appears.

7. Use  to highlight and select **ADD NEW**.



Device being paired should be displayed.

8. Use  to **REFRESH** device list if device does not appear.
9. Use  to highlight and select device.



Progress is then displayed.

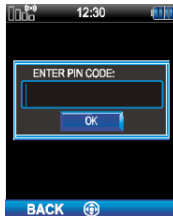

For Bluetooth 2.0 devices, a pin code screen appears.

10. Enter pin code.

11. Use  to select **OK**.



For Bluetooth 2.1 devices, an accept/deny screen appears.

12. Use  to select **ACCEPT**.

NOTE: You will also need to accept the passkey on the Bluetooth 2.1 device as well.

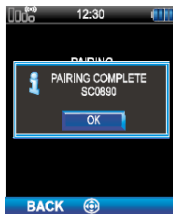

A message appears when pairing is complete.

13. Use  to select **OK**.

Paired device is then displayed under pair devices list.

14. Use  to select **OPTIONS**.

NOTE: Names containing extended ASCII characters may not display correctly.

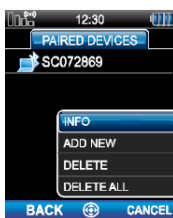

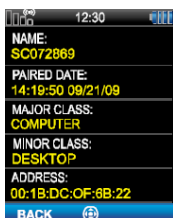

15. Use  to highlight and select choices.

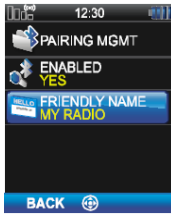

If **INFO** was selected, the paired device information screen appears.

16. Use  to exit menu.



17. Use  to highlight and select **FRIENDLY NAME**. This is the Bluetooth name assigned to the radio. The friendly name used by RPM will overwrite this setting.



18. Enter name for device.

19. Use  to select **OK**.

20. Use  to exit menu.

5.13.5 Clock Settings

1. Enter Settings Menu.

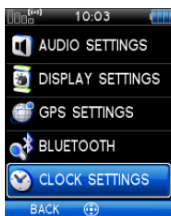

2. Use  to highlight and select **CLOCK SETTINGS**.

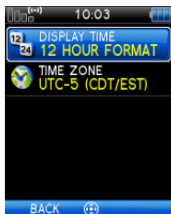

3. Use  to change settings as desired:

- **DISPLAY TIME** - Set 12 or 24 hour time display format.
- **TIME ZONE** - Set time zone relative to Universal Time Coordinated (UTC).

4. Use  to exit menu.

5.13.6 Battery Settings

1. Enter Settings Menu (see Section 5.13).



2. Use  to highlight and select **BATTERY SETTINGS**.

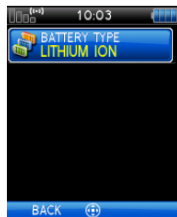

Use only Harris approved batteries. Injury could occur from using incorrect battery.

3. Use  to change settings as desired:
 - **LITHIUM ION** - For accurate battery indication on front and top displays, if battery attached to rear of radio is a Lithium-ION (Li-ION) type.
 - **NIMH** - For accurate indication on front and top displays, if battery attached to rear of radio is a Nickel Metal Hydride (Ni-MH) type.
 - **ALKALINE** - For accurate battery indication on front and top displays, if battery attached to rear of radio is clamshell containing disposable AA alkaline batteries.
 - **PRIMARY LITHIUM** - For accurate battery indication on front and top displays, if battery attached to rear of radio is clamshell containing disposable AA lithium batteries.





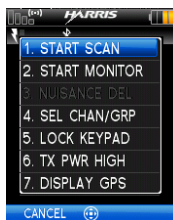

If smart battery is detected, **SMART** is displayed and you will not be able to change the setting. Smart battery shows information such as voltage level, percent charge, and charging state.

4. Use  to exit menu.

5.14 SHORTCUT MENU

1. At main display, use  center button to display the shortcut menu.





2. Use , , , , , , or  to select task:
 - **1 - START/STOP SCAN** - Start or stop scan shortcut menu. **START SCAN** appears if not scanning. **STOP SCAN** appears if scanning.
 - **2 - START/STOP MONITOR** – (P25 Conventional and Analog Conventional) Monitor and squelch types. This is grayed out if radio is scanning.
 - **3 - NUISANCE DEL** – Nuisance delete. This is grayed out if not scanning.
 - **4 – SEL CHAN/GRP** – Select the channel/group bank. If your system has more than 48 channels, this allows you to select a channel group with channels 49-96, 97-144, etc. (A17- A32, B17 – B32, C17 – C32, A33 – A48, etc. is displayed by the radio).
 - **5 - LOCK KEYPAD** – Lock keypad.
 - **6 – TX PWR LOW/HIGH** – Toggle transmit power low or high.
 - **7 – DISPLAY GPS** – Displays the GPS screen.

You can also use  to scroll to the task. You can also press and hold to scroll to the task.

5.14.1 Start or Stop Scan (Shortcut Menu)

1. Enter the Shortcut Menu.



2. To start scan, use  to highlight and select **START SCAN**, or press . **START SCAN** and **NUISANCE DEL** are grayed out if the radio has declared an emergency (TX EMERGENCY).
3. To stop scan, use  to highlight and select **STOP SCAN**.

5.14.2 Monitor and Squelch Types (Conventional Only)

The monitor function allows you to temporarily turn off selected squelch to monitor for traffic that may not normally break squelch. The type of squelch used depends on an analog or digital channel.

For analog channels, there is:

- Noise squelch - any received signal breaks squelch.
- Continuous Tone Coded Squelch (CTCSS) - squelch is selective based on tone code.
- Continuous Digital Coded Squelch (CDCSS) - squelch is selective based on digital code.

For digital channels, there is:

- Monitor squelch - any received digital signal breaks squelch.

- Normal squelch - Received Network Access Code (NAC) breaks squelch.
- Selective squelch - Received NAC and talkgroup Identification (ID) or unit ID breaks squelch.



NOTE

During encrypted operations, the radio will only unmute if receiving with the same key.

1. Enter the Shortcut Menu.

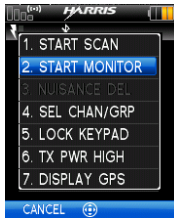

START MONITOR is grayed when radio is scanning.

2. Use to select **START MONITOR**, or press **2 ABC**.
3. Use to select **STOP MONITOR**, or press **2 ABC**.

5.14.3 Nuisance Delete

You can temporarily remove a currently received channel from scan list. This choice is grayed out if the radio is not scanning.



NOTE

Priority 1 and priority 2 channels cannot be nuisance deleted.

1. Enter the Shortcut Menu.

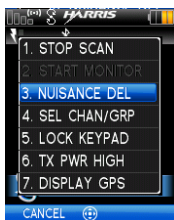

2. Use to select **NUISANCE DEL**, or press **3 DEF**, while receiving on the channel you wish to temporarily remove from scan list.

5.14.4 Select Channel/Group

1. Enter the Shortcut Menu.

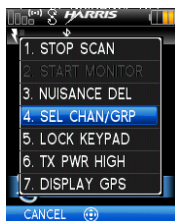

2. Use  to select **SEL CHAN/GRP**, or press .



3. Use  to select **CHAN/GRP**.
 - 1-16: Channels 1-48
 - 17-32: Channels 49-96
 - 33-48: Channels 97-144
 - 49-64: Channels 145-192, etc.

5.14.5 Lock Keypad



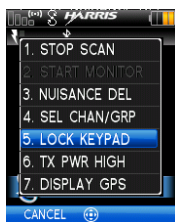

You can lock the keypad to prevent accidental keypad presses.

1. Enter the Shortcut Menu.



2. Use  to select **LOCK KEYPAD**, or press .



3. Use  to unlock keypad. Make sure exact sequence of , , , and  is used. There can be no more than three seconds between key presses. Power cycling radio will **not** unlock the radio.

5.14.6 TX Power Low/High

You can toggle the transmit power between LOW and HIGH.

1. Enter the Shortcut Menu.

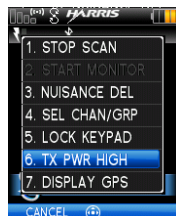

2. Use or press **6 MNO** to select **TX PWR LOW** or **TX PWR HIGH**.

5.14.7 Display GPS

You can access the GPS screen from the shortcut menu.

1. Enter the Shortcut Menu.



2. Use to select **DISPLAY GPS**, or press **7 PQRS**.

5.15 SET UP SCAN

These procedures are used to set up the scan list, home channels, and priority channels. Refer to 4.16.

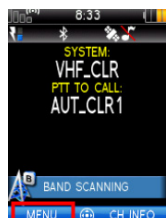

1. At main display, use for main menu.



2. Use to highlight and select **SCAN**, or press **2 ABC**.

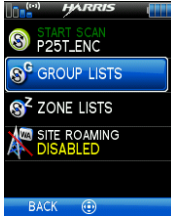

3. Use  to highlight and select **ZONE LISTS** or **GROUP LISTS** and refer to the following sections.

**NOTE**

When using Preemptive Priority Scan, the frequencies in the list need to be unique.

5.15.1 Home, Priority 1, and Priority 2 Channels

5.15.1.1 Home Channel

This is the channel you transmit on by default when you press PTT while the radio is actively scanning and is not responding to a just received call. Responding to a call the radio just received while scanning is called hang time. If hang time is set to 0 in RPM, the radio always transmits on the home channel in scan.

5.15.1.2 Priority 1 Channel

This channel will be scanned more often than other channels in the list and will be scanned in between every other channel in the scan list. An example scan sequence would be P1 (priority 1), C2, P1, C3, P1, C4, etc. Also, the priority channel will be scanned even while actively receiving on a non-priority channel. For example, if the radio is actively receiving on C3 and activity is detected on P1, the radio will drop C3 and switch to P1.

5.15.1.3 Priority 2 Channel

This channel will also be scanned more often than others. An example scan sequence would be P1, C2, P1, C3, P1, C4, P2, C5, P1, C6, P1, C7, P1, C8, P2, C9 etc. Also, this channel will be scanned even while actively receiving on a non-priority channel. For example, if the radio is actively receiving on C3 and activity is detected on P2, the radio will drop C3 and switch to P2. Additionally, activity on P1 can also preempt P2, but P2 cannot preempt P1.

5.15.2 Zone Scan

Zone scan is conventional only and consists of all channels in a zone that are selected as scan channels when generating a mission plan with RPM. Depending on scan options selected in RPM, zone scan lists may be modified to include or exclude channels.

Analog channels using different receive frequencies may be added in any combination of squelch type up to the limits of the size of the scan list.

5.15.3 Group Scan

Group scan is trunked only and allows the radio to monitor many groups simultaneously, permitting the user to both monitor and receive calls from these groups. Depending on scan options selected in RPM, group scan lists may be modified to include or exclude groups.

5.15.4 Vote Scan

If vote scan is enabled via RPM, the radio automatically selects the strongest signal ensuring that the best audio quality is delivered to the user. If vote scan is enabled, the radio is always scanning. You cannot stop scanning, start normal scanning, or monitor the channel. There is an icon in the upper status bar indicating that the radio is vote scanning.



If Talkaround is enabled, Vote Scan is turned off.

5.15.5 Edit Scan List

Depending on the scan list options selected in RPM, you may be able to add or remove channels/groups from the scan list. Zone scan configuration screens are shown below. Group scan configuration is similar.

1. Enter Set up Scan (see Section 5.15) and select group lists or zone list.

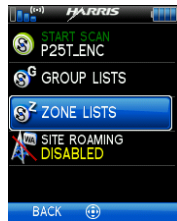

2. Use to highlight scan list.

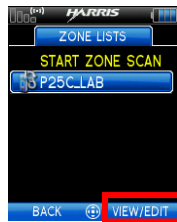

3. Use to select **VIEW/EDIT**.

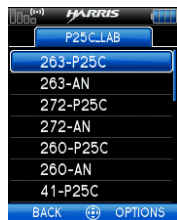

4. Use to highlight channel.
5. Use to select **OPTIONS**.

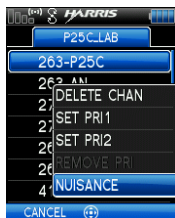

- Use to select **ADD CHAN**, **SET PRI1**, **SET PRI2**, **REMOVE PRI**, or **NUISANCE**.

When a channel is not grayed out in the list, **DELETE CHAN** appears. When a channel is grayed out (not in list), **ADD CHAN** appears.

- Use to select channel.
- Use to toggle channel selection in scan list.
- Use to exit channel list.
- Use to exit scan list.

5.15.6 Set or Remove Priority 1 and Priority 2 Channels

Priority channels are scanned more often than non-priority channels. Note that P1 and P2 can only be set if configured as “Keypad” and the scan list is not set to “Fixed” in RPM.

Zone scan configuration screens are shown below. Group scan configuration is similar.

- Enter Set up Scan (see Section 5.15).

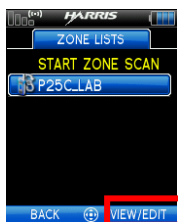

- Use to highlight scan list.
- Use to select **VIEW/EDIT**.

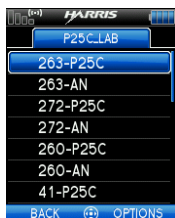

- Use to highlight channel.
- Use to select **OPTIONS**.

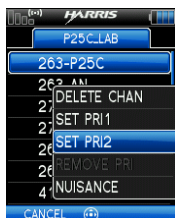

Use to highlight and select **SET PRI1** or **SET PRI2**. Priority 1 channel appears with a P1 and Priority 2 channel appears with a P2.

Select **REMOVE PRI** to remove priority.

- Use to exit channel list.
- Use to exit scan list.

5.15.7 Wide Area System Scan (P25 Trunked Only)

Wide Area System Scan (WASCAN) causes the radio to roam across mobile systems when the currently selected system's control channel is lost. The radio will scan the control channels of other systems.

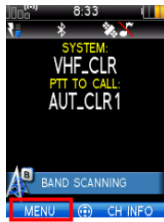

1. At main display, use to select **MENU**.

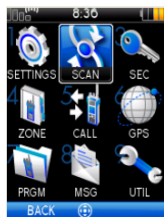

2. Use to highlight and select **SCAN**, or press .

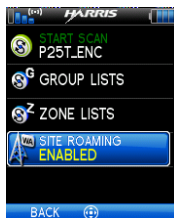

3. Use to highlight and enable **SITE ROAMING**.
4. Use to select **BACK** and exit scan menu.

5.16 MESSAGE MENU



1. At main display, use for main menu.



2. Use to highlight and select **MESSAGE**, or press .

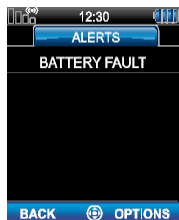

3. Observe messages in display.

NOTE: The alert icon goes away when you go to the message display (unless a new fault occurs).

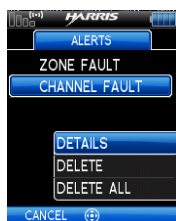

4. Use to select **OPTIONS**.

5. Use to highlight and select **DETAILS, DELETE, or DELETE ALL**.

6. **NOTE:** If you view but do not delete the fault, the alert icon goes away.

For **DETAILS**:

- **BATTERY FAULT**
- **BATTERY COMMS FAULT** - replace battery.
- **NON-STANDARD BATTERY** - replace battery.
- **EEPROM FAULT** - contact Harris.
- **RF FAULT**
- **OVERCURRENT** - Check antenna and antenna connection. Try replacing antenna.
- **ZONE FAULT** – Feature not installed.
- **CHANNEL FAULT** – Feature not installed.



NOTE

Contact Harris for assistance diagnosing a fault.

7. Use to exit back to main screen.

5.17 UTILITY MENU

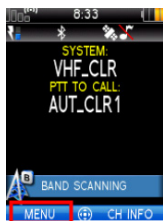

1. At main display, use for main menu.



2. Use to highlight and select **UTILITY**, or press .



- Use to highlight and select **SELF TEST** to run a series of internal radio tests.

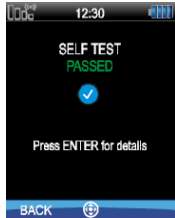

Status screen appears while testing followed by a screen with passed or failed results.

- Use to view details.

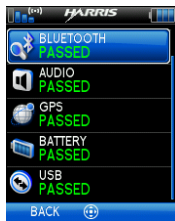

- Use to scroll through the test results.
- Use to exit screen.



- Use to highlight and select **RADIO INFO** to view radio information such as software and firmware revisions.
- Observe radio information display.
- Use to exit screen.



- Use to highlight and select **BATTERY INFO**.

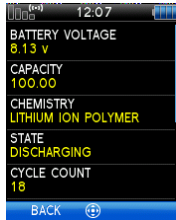

11. Observe voltage for the attached non-smart battery.
12. Use to scroll through smart battery status, if smart battery is attached.
13. Use to exit screen.

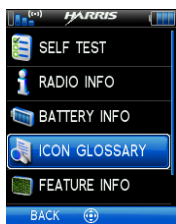
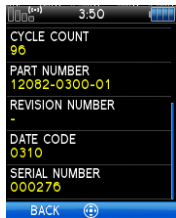

14. Use to highlight and select **ICON GLOSSARY**.



15. Observe icon glossary of terms.
16. Use to scroll through additional pages.
17. Use to exit screen.

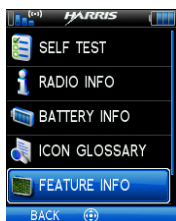

18. Use to highlight and select **FEATURE INFO**.
19. Use to change between the **FEATURE DATA** tab and the **FEATURES** tab. From here, you can observe enabled features.
20. Use to exit screen.



21. Use to highlight and select **TCXO TUNING**.
This function only appears if the maintenance password is configured in RPM.



22. Enter the password.



This function is for maintenance personnel only. Improper adjustment will result in loss of communications.

23. Use to exit screen.

24. Use to exit main screen.



25. If a P25 channel is selected, use to highlight and select **TESTS**. Enter the password to access the P25 tests. This function is for maintenance personnel only.

26. Use to exit screen.

27. Use to exit main screen.

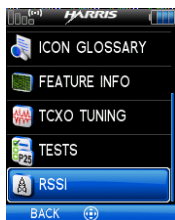

28. Use to highlight and select **RSSI**.



29. Enable or Disable **DISPLAY RSSI**. When enabled, RSSI is displayed on the RSSI screen and in the bottom right corner of the main display.

NOTE: -130 dBm is displayed when there is no signal.



6. PROGRAMMING

This section provides information on front panel programming. Programming can also be accomplished by creating a plan using a computer with RPM version R6A or later installed.

6.1 PROGRAMMING VIA RPM

Radio Personality Manager (RPM) is used for the bulk of programming the XG-100P. With RPM, you can fully program the XG-100P using cable 12082-0410-A1.

6.2 EDIT CHANNEL (CONVENTIONAL ONLY)

Channels can be edited from the Channel Information (CH INFO) menu display. Most of the displayed channel parameters can be modified here. Channel edits persist across a power cycle. Loading a mission plan clears any channel edits.

Available parameters vary depending on whether the channel is a digital or analog channel. A digital channel allows you to receive digital or analog signals. When transmitting on a digital channel, you can transmit either a digital or analog signal, depending on how the channel is programmed.



1. At main display, use for Channel Information menu.

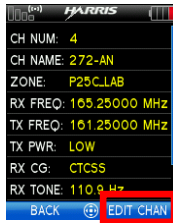

2. Use to scroll through the programmed channel settings.
 3. Additional settings can be found by scrolling down.
- CAUTION: Only authorized users should attempt channel editing.
4. Use to select **EDIT CHAN**.

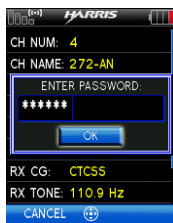

- Password protection is automatically enabled by default.
5. Enter the password programmed via RPM. You do not have to re-enter the password until you power cycle the radio.
 6. Use to select **OK**.

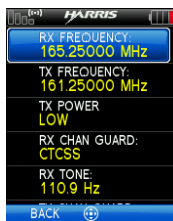

7. Use to highlight and select **RX FREQUENCY**.

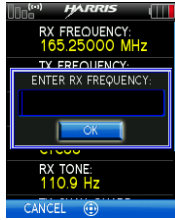

8. Enter new receive frequency.

If the new frequency is invalid, the display reverts back to the old frequency (Table 6-1).

9. Use  to select **OK**.

10. Use  to cancel.

11. For digital channel, modify remaining channel settings:

- **TX FREQUENCY** - Transmit frequency.
- **TX POWER** – Transmit power. Toggle between **LOW** and **HIGH**.
- **TALKGROUP** – Select a talkgroup for the channel. Talkgroup name cannot be set here.
- **RX NAC** - Network Access Code (NAC) radio uses for Normal squelch in receive.
- **TX NAC** - NAC radio transmits to break Normal squelch on receiving radio.
- **P25 SQUELCH** – Select type the radio uses in receive. Select **NORMAL**, **SELECTIVE**, or **MONITOR**.
- **RX CHAN GUARD** – Squelch type radio uses in receive. Select **Noise**, **CTCSS**, or **CDCSS**. **For a digital channel, the RX CHAN GUARD is used to receive from a Conventional analog channel that is on the same frequency and uses the selected Channel Guard.**
 - **RX CODE** - Code radio looks to unmute the speaker on the receiving radio when **CDCSS** squelch is used in conventional mode.
 - **RX TONE** - Tone radio looks to unmute the speaker on the receiving radio when **CDCSS** squelch is used in conventional mode.

12. For analog channel, modify remaining channel settings:

- **TX FREQUENCY** - Transmit frequency.
- **TX POWER** – Transmit power. Toggle between **HIGH** and **LOW**.
- **RX CHAN GUARD** – Squelch type radio uses in receive. Select **Noise**, **CTCSS**, or **CDCSS**.
 - **RX TONE** - Tone radio uses to break selective squelch on receiving radio. This is available when **RX** squelch is set to **CTCSS**.
 - **RX CODE** - Code radio uses to break selective squelch on receiving radio. This is available when **RX** squelch is set to **CDCSS**.
- **TX CHAN GUARD** – Squelch type radio uses in transmit. Select **None**, **CTCSS**, or **CDCSS**.
 - **TX TONE** - Tone sent by transmitting radio to allow receiving radio to unmute when **CDCSS** squelch is used in conventional mode.
 - **TX CODE** - Code sent by transmitting radio to allow receiving radio to unmute when **CDCSS** squelch is used in conventional mode.

13. Use  to exit menu.

Table 6-1: Valid Frequencies

FREQUENCY RANGE	FREQUENCY RESOLUTION
136 - 174 MHz	2500, 5000, or 6250 Hz
380 - 520 MHz	2500, 5000, or 6250 Hz
762 - 870 MHz	6250 kHz

6.3 PROGRAMMABLE HOT KEY AND BUTTONS

The programmable hot key and buttons shown in XG-100P Controls are programmed using RPM. You can program hot key and buttons for the following:

- P25 Squelch
- Secure Clear
- Backlight Toggle - Off, On, Momentary
- Scan
- Flip Top Display
- Lock Keypad
- Nuisance Delete
- Talkaround/Direct
- Speaker Mute
- Zone Up
- Zone Down
- Zone Up Wrap
- Zone Down Wrap
- Select Group Set
- Drop Call

7. REFERENCE

7.1 MARINE FREQUENCIES

Refer to Table 7-1: Marine Frequencies for a list of maritime frequencies per United States Coast Guard (USCG), National Oceanic and Atmospheric Administration (NOAA), and Canadian Department Fisheries and Oceans, August 2009:

- United States (US)
- International (Intl)
- Canada (CA)

Table 7-1: Marine Frequencies

CHANNEL			FREQUENCY		CHANNEL USAGE
US	INTL	CA	SHIP (MHZ)	SHORE (MHZ)	
	1	1	T: 156.05 R: 160.65	T: 160.65 R: 156.05	International: Public Correspondence, Port Operations
1a			T/R: 156.05	T/R: 156.05	US: Port Operations and Commercial, Vessel Traffic Service (VTS). New Orleans/Lower Mississippi area.
	2	2	T: 156.10 R: 160.70	T: 160.70 R: 156.10	International: Public Correspondence, Port Operations
	3	3	T: 156.15 R: 160.75	T: 160.75 R: 156.15	International: Public Correspondence, Port Operations
	4		T: 156.20 R: 160.80	T: 160.80 R: 156.20	International: Public Correspondence, Port Operations
		4a	T/R: 156.20	T/R: 156.20	Canada: Department Fisheries Ocean (DFO)/Canadian Coast Guard only in British Columbia coast area. Commercial fishing in east coast area
	5		T: 156.25 R: 160.85	T: 160.85 R: 156.25	International: Public Correspondence, Port Operations
5a		5a	T/R: 156.25	T/R: 156.25	US: Port Operations or VTS in Houston, New Orleans and Seattle areas.
6	6	6	T/R: 156.30	T/R: 156.30	US: Intership Safety International: Intership Canada: May be used for search and rescue communications between ships and aircraft.
	7		T: 156.35 R: 160.95	T: 160.95 R: 156.35	International: Public Correspondence, Port Operations
7a		7a	T/R: 156.35	T/R: 156.35	US: Commercial
8	8	8	T/R: 156.40	T/R: 156.40	US: Commercial (Intership only) International: Intership Canada: Also assigned for intership in the Lake Winnipeg area.
9	9	9	T/R: 156.45	T/R: 156.45	US: Boater Calling. Commercial and Non-Commercial. International: Intership, Port Operations Canada: Commercial - British Columbia coast area. May be used to communicate with aircraft and helicopters in predominantly maritime support operations.

Table 7-1: Marine Frequencies

CHANNEL			FREQUENCY		CHANNEL USAGE
US	INTL	CA	SHIP (MHZ)	SHORE (MHZ)	
10	10	10	T/R: 156.50	T/R: 156.50	US: Commercial International: Intership, Port Operations Canada: Commercial - British Columbia coast area. May also be used for communications with aircraft engaged in coordinated search and rescue and antipollution operations.
11	11	11	T/R: 156.55	T/R: 156.55	US: Commercial. VTS in selected areas. International: Port Operations Canada: VTS - British Columbia coast area. Also used for pilotage purposes.
12	12	12	T/R: 156.60	T/R: 156.60	US: Port Operations. VTS in selected areas. International: Port Operations Canada: VTS - British Columbia coast area. Also used for pilotage purposes.
13	13	13	T/R: 156.65	T/R: 156.65	US: Intership Navigation Safety (Bridge-to-bridge). Ships >20m length maintain a listening watch on this channel in US waters. International: Intership, Port Operations Canada: VTS - British Columbia coast area. Also used for pilotage purposes.
14	14	14	T/R: 156.70	T/R: 156.70	US: Port Operations. VTS in selected areas. International: Port Operations Canada: VTS - British Columbia coast area. Also used for pilotage purposes.
15	15	15	T/R: 156.75	T/R: 156.75	US: Environmental (Receive only). Used by Class C Emergency Position-Indicating Radio Beacons (EPIRBs). International: Intership, Port Operations Canada: Port operations and Ship Movement - British Columbia coast area. All operations limited to 1-watt maximum power. May also be used for on-board communications.
16	16	16	T/R: 156.80	T/R: 156.80	US: International Distress, Safety and Calling. Ships required to carry radio, US Coast Guard (USCG), and most coast stations maintain a listening watch on this channel. International: International Distress, Safety and Calling Canada: International Distress, Safety and Calling
17	17	17	T/R: 156.85	T/R: 156.85	US: State Control International: Intership, Port Operations Canada: Port operations and Ship Movement - British Columbia coast area. All operations limited to 1 watt maximum power. May also be used for on-board communications.
	18		T: 156.90 R: 161.50	T: 161.50 R: 156.90	International: Public Correspondence, Port Operations
18a		18a	T/R: 156.90	T/R: 156.90	US: Commercial Canada: Towing - British Columbia coast area.
	19		T: 156.95 R: 161.55*	T: 161.55* R: 156.95	International: Public Correspondence, Port Operations
19a		19a	T/R: 156.95	T/R: 156.95	US: Commercial Canada: DFO/Canadian Coast Guard. Pacific Pilots - British Columbia coast area.

Table 7-1: Marine Frequencies

CHANNEL			FREQUENCY		CHANNEL USAGE
US	INTL	CA	SHIP (MHZ)	SHORE (MHZ)	
20	20	20	T: 157.00 R: 161.60	T: 161.60 R: 157.00	US: Port Operations (Duplex) International: Public Correspondence, Port Operations Canada: Port operations only with 1 watt maximum power.
20a			T/R: 157.00	T/R: 157.00	US: Port Operations
	21		T: 157.05 R: 161.65*	T: 161.65* R: 157.05	International: Public Correspondence, Port Operations
21a		21a	T/R: 157.05	T/R: 157.05	US: US Coast Guard only Canada: DFO/Canadian Coast Guard only.
		21b	--	T/R: 161.65	
	22		T: 157.10 R: 161.70	T: 161.70 R: 157.10	International: Public Correspondence, Port Operations
22a		22a	T/R: 157.10	T/R: 157.10	US: Coast Guard Liaison and Maritime Safety Information Broadcasts. Broadcasts announced on channel 16. Canada: For communications between Canadian Coast Guard and non-Canadian Coast Guard stations only.
	23	23	T: 157.15 R: 161.75	T: 161.75 R: 157.15	International: Public Correspondence, Port Operations
23a			T/R: 157.15	T/R: 157.15	US: US Coast Guard only
		23b	--	T/R: 161.75	Canada: Continuous Marine Broadcast (CMB) service.
24	24	24	T: 157.20 R: 161.80	T: 161.80 R: 157.20	US: Public Correspondence (Marine Operator) International: Public Correspondence, Port Operations
25	25	25	T: 157.25 R: 161.85	T: 161.85 R: 157.25	US: Public Correspondence (Marine Operator) International: Public Correspondence, Port Operations Canada: Also assigned for operations in the Lake Winnipeg area.
		25b		T/R: 161.85	
26	26	26	T: 157.30 R: 161.90	T: 161.90 R: 157.30	US: Public Correspondence (Marine Operator) International: Public Correspondence, Port Operations
27	27	27	T: 157.35 R: 161.95	T: 161.95 R: 157.35	US: Public Correspondence (Marine Operator) International: Public Correspondence, Port Operations
28	28	28	T: 157.40 R: 162.00	T: 162.00 R: 157.40	US: Public Correspondence (Marine Operator) International: Public Correspondence, Port Operations
		28b	--	T/R: 162.00	Canada: Continuous Marine Broadcast (CMB) service.
	60	60	T: 156.025 R: 160.625	T: 160.625 R: 156.025	International: Public Correspondence, Port Operations
	61		T: 156.075 R: 160.675	T: 160.675 R: 156.075	International: Public Correspondence, Port Operations
61a		61a	T/R: 156.075	T/R: 156.075	Canada: DFO/Canadian Coast Guard only in British Columbia coast area.

Table 7-1: Marine Frequencies

CHANNEL			FREQUENCY		CHANNEL USAGE
US	INTL	CA	SHIP (MHZ)	SHORE (MHZ)	
	62		T: 156.125 R: 160.725	T: 160.725 R: 156.125	International: Public Correspondence, Port Operations
		62a	T/R: 156.125	T/R: 156.125	Canada: DFO/Canadian Coast Guard only in British Columbia coast area.
	63		T: 156.175 R: 160.775	T: 160.775 R: 156.175	International: Public Correspondence, Port Operations
63a		63a	T/R: 156.175	T/R: 156.175	US: Port Operations and Commercial, VTS. New Orleans/Lower Mississippi area. Canada: Tow Boats - British Columbia coast area.
	64	64	T: 156.225 R: 160.825	T: 160.825 R: 156.225	International: Public Correspondence, Port Operations
64a		64a	T/R: 156.225	T/R: 156.225	Canada: Commercial fishing only.
	65		T: 156.275 R: 160.875	T: 160.875 R: 156.225	International: Public Correspondence, Port Operations
65a		65a	T/R: 156.275	T/R: 156.275	US: Port Operations Canada: Search and rescue and antipollution operations on the Great Lakes. Towing on the Pacific Coast. Port operations only in the St. Lawrence River areas with 1 watt maximum power. Intership in inland Manitoba, Saskatchewan, and Alberta areas.
	66		T: 156.325 R: 160.925	T: 160.925 R: 156.325	International: Public Correspondence, Port Operations
66a		66a	T/R: 156.325	T/R: 156.325	US: Port Operations Canada: Port operations only in the St. Lawrence River/Great Lakes areas with 1 watt maximum power. 1 watt marina channel - British Columbia coast area.
67	67	67	T/R: 156.375	T/R: 156.375	US: Commercial. Used for Bridge-to-bridge communications in lower Miss. River. Intership only. International: Intership, Port Operations Canada: May also be used for communications with aircraft engaged in coordinated search and rescue and antipollution operations. Commercial fishing only in east coast and inland Manitoba, Saskatchewan, and Alberta areas. Pleasure craft - British Columbia coast area.
68	68	68	T/R: 156.425	T/R: 156.425	US: Non-Commercial International: Port Operations Canada: For marinas, yacht clubs and pleasure craft.
69	69	69	T/R: 156.475	T/R: 156.475	US: Non-Commercial International: Intership, Port Operations Canada: Commercial fishing only - east coast area. Pleasure craft - British Columbia coast area.
70	70	70	T/R: 156.525	T/R: 156.525	US: Digital Selective Calling (voice communications not allowed) International: Digital selective calling for distress, safety and calling Canada: Digital selective calling for distress, safety and calling
71	71	71	T/R: 156.575	T/R: 156.575	US: Non-Commercial International: Port Operations Canada: Ship Movement - British Columbia coast area. Marinas and yacht clubs - east coast and on Lake Winnipeg.

Table 7-1: Marine Frequencies

CHANNEL			FREQUENCY		CHANNEL USAGE
US	INTL	CA	SHIP (MHZ)	SHORE (MHZ)	
72	72	72	T/R: 156.625	T/R: 156.625	US: Non-Commercial (Intership only) International: Intership Canada: May be used to communicate with aircraft and helicopters in predominantly maritime support operations. Pleasure craft - British Columbia coast area
73	73	73	T/R: 156.675	T/R: 156.675	US: Port Operations International: Intership, Port Operations Canada: May also be used for communications with aircraft engaged in coordinated search and rescue and antipollution operations. Commercial fishing only in east coast and inland Manitoba, Saskatchewan, and Alberta areas.
74	74	74	T/R: 156.725	T/R: 156.725	US: Port Operations International: Port Operations Canada: VTS and Ship Movement British Columbia coast area.
75	75	75	T/R: 156.775	T/R: 156.775	International: Port Operations Canada: Simplex port operation, ship movement and navigation related communication only. 1 watt maximum.
76	76	76	T/R: 156.825	T/R: 156.825	International: Port Operations Canada: Simplex port operation, ship movement and navigation related communication only. 1 watt maximum.
77	77	77	T/R: 156.875	T/R: 156.875	US: Port Operations (Intership only) International: Intership Canada: Pilotage - British Columbia coast area; 25 watts. Port operations only in the St. Lawrence River/Great Lakes areas with 1 watt maximum power.
	78		T: 156.925 R: 161.525	T: 161.525 R: 156.925	International: Public Correspondence, Port Operations
78a		78a	T/R: 156.925	T/R: 156.925	US: Non-Commercial Canada: Fishing Industry - British Columbia coast area.
	79		T: 156.975 R: 161.575	T: 161.575 R: 156.975	International: Public Correspondence, Port Operations
79a		79a	T/R: 156.975	T/R: 156.975	US: Commercial. Non-Commercial in Great Lakes only Canada: Fishing Industry - British Columbia coast area.
	80		T: 157.025 R: 161.625	T: 161.625 R: 157.025	International: Public Correspondence, Port Operations
80a		80a	T/R: 157.025	T/R: 157.025	US: Commercial. Non-Commercial in Great Lakes only Canada: Fishing Industry - British Columbia coast area.
	81		T: 157.075 R: 161.675	T: 161.675 R: 157.075	International: Public Correspondence, Port Operations
81a		81a	T/R: 157.075	T/R: 157.075	US: US Government only - Environmental protection operations Canada: DFO/Canadian Coast Guard use only.
	82		T: 157.125 R: 161.725	T: 161.725 R: 157.125	International: Public Correspondence, Port Operations
82a		82a	T/R: 157.125	T/R: 157.125	US: US. Government only Canada: DFO/Canadian Coast Guard use only.

Table 7-1: Marine Frequencies

CHANNEL			FREQUENCY		CHANNEL USAGE
US	INTL	CA	SHIP (MHZ)	SHORE (MHZ)	
	83		T: 157.175 R: 161.775	T: 161.775 R: 157.175	International: Public Correspondence, Port Operations
83a		83a	T/R: 157.175	T/R: 157.175	US: US Coast Guard only Canada: DFO/Canadian Coast Guard and other Government agencies.
		83b	--	T/R: 161.775	
84	84	84	T: 157.225 R: 161.825	T: 161.825 R: 157.225	US: Public Correspondence (Marine Operator) International: Public Correspondence, Port Operations
85	85	85	T: 157.275 R: 161.875	T: 161.875 R: 157.275	US: Public Correspondence (Marine Operator) International: Public Correspondence, Port Operations
86	86	86	T: 157.325 R: 161.925	T: 161.925 R: 157.325	US: Public Correspondence (Marine Operator) International: Public Correspondence, Port Operations
87	87	87	T: 157.375 R: 161.975	T: 161.975 R: 157.375	US: Automatic Identification System duplex repeater International: Port Operations Canada: Port operation and ship movement - east coast area. Pleasure craft - British Columbia coast area.
87a			T/R: 157.375	T/R: 157.375	US: Public Correspondence (Marine Operator)
		87b	T/R: 161.975	T/R: 161.975	Canada: Automatic Ship Identification and Surveillance System.
	88	88	T: 157.425 R: 162.025	T: 162.025 R: 157.425	US: Commercial, Intership only. International: Port Operations Canada: Port operation and ship movement - British Columbia coast area.
88a			T/R: 157.425	T/R: 157.425	US: Commercial, Intership only. Canada: Automatic Ship Identification and Surveillance System.
		88b	T/R: 162.025	T/R: 162.025	
WX1		WX1		R: 162.55	
WX2		WX2		R: 162.4	
WX3		WX3		R: 162.475	
WX4				R: 162.425	
WX5				R: 162.45	
WX6				R: 162.5	
WX7				R: 162.525	

7.2 ACCESSORIES

Only use Harris approved accessories. Refer to Harris' Product and Services catalog for the complete list of options and accessories available. Contact Harris for requirements not contained in this list:



Always use the correct options and accessories (battery, antenna, speaker/mic, etc.) for the radio. Factory Mutual options must be used with Factory Mutual certified radios. (Refer to Table 7-2).

Table 7-2: Options and Accessories

DESCRIPTION	PART NUMBER
ANTENNAS	
Full-Spectrum, 136-870 MHz frequency coverage	XPNC8A
Flexible Antenna, Unity, 136-870 MHz, Helical	XPNC8B
6" Antenna, Unity, 160-870 MHz, Helical	XPNC8C
BATTERIES/CHARGERS	
Nickel Metal Hydride (NiMH) Battery, [FM]	BT-023406-004
Extra High Capacity Nickel Metal Hydride (NiMH) Battery, [FM]	BKB191210/36
Battery, Li-Polymer	XPPA3A
1-Bay Charger- Multi-chemistry battery charger, supports radio operation while charging	XPCH4A
6-Bay Charger – Lithium only, multi-bay battery charger	XPCH4B
MISCELLANEOUS ACCESSORIES	
Standard Remote Speaker Microphone - Rugged, submersible, 6 ft. (stretch length) coil cord, swivel clip, 3.5 mm earpiece interface, high/low volume control	XPAE9N
Belt Clip - Supports carrying of the XG-100P on a belt	XPHC3L
Leather Carry Cases - Durable radio carry-cases selectable with swivel D-clip belt-loops or T-straps. Various styles available	XPHC3x
Nylon Carry Cases - Nylon radio carry cases available in various styles and configurations	XPHC3x
USB Cable - USB computer interface cable for use with RPM and for Key Loading using Harris Key Loader for the XG-100P	XPCJ3A
KVL Cable - Adapter cable supports loading encryption keys with the Motorola KVL 3000 Plus	dual C
AA Clamshell - Battery pack for use with AA-sized batteries	XPPA2H

8. GLOSSARY

-A-

AES	Advanced Encryption Standard
AES-256	Advanced Encryption Standard, 256-bit
AMBE+2	Advanced Multi-Band Excitation implementation 2
ANSI	American National Standards Institute
ASCII	American Standard Code for Information Interchange

-B-

-C-

C	Celsius
CA	Canada
CDCSS	Continuous Digital Coded Squelch System
CH INFO	Channel Information
CKR	Common Key References
CMB	Continuous Marine Broadcast
CTCSS	Continuous Tone Coded Squelch System

-D-

DES	Digital Encryption Standard
DES-OFB	Digital Encryption Standard Output Feedback
DFO	Department Fisheries Ocean
DMS	Degrees Minutes Seconds

-E-

EPIRB	Emergency Position-Indicating Radio Beacons
--------------	---

-F-

F	Fahrenheit
FCC	Federal Communications Commission
FM	Frequency Modulation

-G-

GHz	Giga (10 ⁹) Hertz
GEOTRANS	Geographic Translator
GPS	Global Positioning System

-H-

Hz	Hertz
HKL	Harris Key Loader

-I-

ID	Identification
IEEE	Institute of Electrical & Electronics Engineers
INTL	International

-J-

-K-

KEK	Key Encryption Key
kHz	kilo (10 ³) Hertz
KID	Key Identification
KMF	Key Management Facility
KMS	Key Management System
KS	Key Set
KVL	Key Variable Loader (Motorola KVL 3000 Plus)

-L-

LAT/LONG DMS	Latitude/Longitude Degrees Minutes Seconds
LED	Light Emitting Diode
Li-ION	Lithium-ION

-M-

MHz	Megahertz
mm	Millimeter
MR	Mobile Radio
ms	milli (10 ⁻³) seconds

-N-

NAC	Network Access Code
Ni-MH	Nickel Metal Hydride
NOAA	National Oceanic and Atmospheric Administration

-O-

OET	Office of Engineering and Technology
OTAR	Over The Air Rekey

-P-

P25	Project 25
POS	Position
PRI	Priority (Channel)
PTT	Push-to-Talk

-Q-**-R-**

RF	Radio Frequency
RPM	Radio Personality Manager
RSI	Radio Set Identifier
RSM	Remote Speaker Microphone
RX	Receive

-S-

SMA	Subminiature version A
------------	------------------------

-T-

TIA	Telecommunications Industry Association
TX	Transmit

-U-

UHF	Ultra High Frequency
UKEK	Unique Key Encryption Key
US	United States
USCG	United States Coast Guard
UTC	Universal Time Coordinated
UTM	Universal Transverse Mercator

-V-

VDC	Volts, Direct Current
VHF	Very High Frequency
VTS	Vessel Traffic Service

-W-

WEEE	Waste from Electric and Electronic Equipment
-------------	--

-X-**-Y-****-Z-**

9. BASIC TROUBLESHOOTING

9.1 ERROR MESSAGES

This section provides a list of error messages, as well as possible causes and solutions.

SCREEN	TEXT	REASON	RESOLUTION
Top Level Display	DELETE NOT ALLOWED	Nuisance delete not allowed on current channel.	Requires new personality configuration (either Limited/Programmable scan lists or Keypad P1/P2 channels).
	EMERGENCY ACTIVE SCAN DISABLED	Cannot scan when transmitting an emergency.	Exit emergency to start scanning.
	OTAR REKEY FAILED	Self-explanatory	Attempt OTAR operation again.
	OTAR ZEROIZE FAILED		Attempt OTAR operation again.
	NO OTAR KEK LOADED		Load valid KEK before attempting OTAR.
	INVALID OTAR KEYSETS	OTAR configuration failed because keysets were improperly configured.	Zeroize keys and reload KEK(s) before attempting OTAR.
	INVALID KEYSTORE ZEROIZE NEEDED	Corrupt key database.	Zeroize database.
	SYNTH OUT OF LOCK	DSP synthesizer out of lock.	Channel will reselect automatically to attempt to obtain synth lock.
	SYNTH OUT OF LOCK POWER CYCLE RADIO	DSP synthesizer out of lock - unable to restore by reselecting channel.	Unable to obtain synthesizer lock. Power cycle radio and contact Harris if problem persists.
Bluetooth Pairing Screen	PAIRING FAILED	Bluetooth pairing failed.	Ensure device is discoverable and attempt to re-pair the device.
	PIN CODE MUST HAVE AT LEAST 4 DIGITS	The PIN entered is too short.	Enter at least four digits.
Channel Edit Screen	EDIT FAILED	Unable to modify P25 Channel	Power cycle and try again--contact Harris if problem persists
	INVALID RX FREQUENCY	Entered Rx frequency is invalid.	Ensure frequency follows band spacing rules.
	INVALID TX FREQUENCY	Entered Tx frequency is invalid.	Ensure frequency follows band spacing rules.
	INVALID CODE	Code entered is not a valid CDCSS code.	Ensure code is valid.
Mission Plan List Screen	EMERGENCY ACTIVE FILL DISABLED	Cannot activate mission plans when transmitting an emergency.	Exit emergency to activate a new mission plan.

SCREEN	TEXT	REASON	RESOLUTION
Install Operations	INSTALL NOT ALLOWED	Error during install process.	Transfer the file again and reattempt install. Contact Harris if problem persists.
	EXTRACTION FAILED	Extraction of compressed file failed.	Transfer file again and reattempt install. Contact Harris if problem persists
	REMOVE FAILED	Removal of existing software failed	Attempt to install again and contact Harris if problem persists.
Mission Plan In Progress Screen	PLAN FAILED	Mission plan activation failed.	Use RPM to ensure plan validity. Contact Harris if failures persist.
Security Menu	ZEROIZE FAILED	DSP could not zeroize	DSP problem — power cycle the radio and contact Harris if problem persists.
	NO KEYS TO ZEROIZE	Key database empty.	Nothing to zeroize.
Utilities Menu	INCORRECT PASSWORD	Maintenance password invalid.	Enter a valid maintenance password.
Channel Info Screen	INCORRECT PASSWORD	Channel edit password invalid.	Enter valid channel edit password.

9.2 OTAR ERRORS/INFORMATION

WORKAROUNDS:

1. Zeroize.
2. Load proper KEK from the Motorola KVL or Harris UKEK Loader.

IF RADIO INDICATES:

1. INVALID KEYSTORE ZEROIZE NEEDED:

This occurs if the radio's keys were loaded by the Harris Key Loader followed by an attempt to load UKEKs with the UKEK Loader or keys with the Motorola KVL. Fix by performing workaround 1, followed by 2.

2. NO UKEK – Displayed during a zeroize performed from the radio or a zeroize initiated from the KMF.
 - Fix by performing workaround 2.
3. Zeroize Complete – KMF has zeroized the radio.
 - Fix by performing workaround 2.
4. Disabled OTAR Icon (red slash) – OTAR is disabled while in scan, talkaround, emergency, and monitor.
 - Fix by disabling these features. Icon will be corrected (no red slash).
5. Gray OTAR Icon (no red slash) – OTAR has not registered with tower (Conventional or Trunked system).
 - Fix by verifying proper frequencies.
 - If the radio is turned to the OTAR channel out of range of a conventional tower, and then comes in range after 3 minutes, fix by issuing an OTAR. Rekey, leaving and re-enter the OTAR channel.

6. Green OTAR Icon – OTAR is registered, all is well.
 - If update fails, verify you are in range of the tower and the KEK is correct.
7. Blue OTAR Icon – OTAR is attempting to rekey.
 - If rekey fails, verify you are in range of the tower and the KEK is correct.

10. TECHNICAL ASSISTANCE

The Technical Assistance Center's (TAC) resources are available to help with overall system operation, maintenance, upgrades and product support. TAC is the point of contact when answers are needed to technical questions.

Product specialists, with detailed knowledge of product operation, maintenance and repair provide technical support via a toll-free (in North America) telephone number. Support is also available through mail, fax and e-mail.

For more information about technical assistance services, contact your sales representative, or contact the Technical Assistance Center directly at:

North America:	1-800-528-7711
International:	1-434-385-2400
Fax:	1-434-455-6712
E-mail:	PSPC-tac@harris.com

11. RECHARGEABLE BATTERY WARRANTY

- A. Harris Corporation, a Delaware Corporation, through its RF Communications Division (hereinafter "Seller") warrants to the original purchaser for use (hereinafter "Buyer") that nickel-cadmium, nickel-metal hydride, lithium-ion, and lithium-polymer batteries supplied by Seller shall be free from defects in material and workmanship, and shall conform to its published specifications for a period of twelve (12) months from the date of purchase.
- B. For purposes of this warranty, batteries shall be deemed defective if (1) the battery capacity is less than 80% rated capacity, or (2) the battery develops leakage.
- C. If any battery fails to meet the foregoing warranty, Seller shall correct the failure by issuing a replacement battery upon receipt of the defective battery at an Authorized Service Center (ASC) or Seller factory (for OpenSky[®] Equipment only).
- D. Replacement batteries shall be warranted only for the remaining unexpired warranty period of the original battery. This warranty becomes void if:
 - 1. The battery has been subjected to any kind of misuse, detrimental exposure, or has been involved in an accident.
 - 2. The battery is used in equipment or service other than the radio equipment for which it is specified.
- E. The preceding paragraphs set forth the exclusive remedies for claims based upon defects in or non-conformity of any battery, whether the claim is in contract, warranty, tort (including negligence), strict liability or otherwise, and however instituted. Upon the expiration of the warranty period, all such liability shall terminate. The foregoing warranties are exclusive and in lieu of all other warranties, whether oral, written, expressed, implied or statutory. **NO IMPLIED OR STATUTORY WARRANTIES OF MERCHANTABILITY OR FITNESS FOR PARTICULAR PURPOSE SHALL APPLY. IN NO EVENT SHALL THE COMPANY BE LIABLE FOR ANY INCIDENTAL, CONSEQUENTIAL, SPECIAL, INDIRECT OR EXEMPLARY DAMAGES.**

This warranty applies only within the United States.

To obtain the name and address of an Authorized Service Center (ASC), ask your salesperson, or call one of the factory number(s) printed at the bottom of this page.

Harris Corporation
RF Communications Division
221 Jefferson Ridge Parkway
Lynchburg, VA 24501
1-800-528-7711

Harris Corporation
RF Communications Division
1680 University Avenue
Rochester, NY 14610
1-585-244-5830

ECR-7048D

12. WARRANTY

Please register this product within 10 days of purchase. Registration validates the warranty coverage, and enables Harris to contact you in case of any safety notifications issued for this product.

Registration can be made on-line at <http://www.pspc.harris.com/Service/WarrantySupport.asp>.

- A. Harris Corporation, a Delaware Corporation, through its RF Communications Division (hereinafter "Seller") warrants to the original purchaser for use (hereinafter "Buyer") that Equipment manufactured by or for the Seller shall be free from defects in material and workmanship, and shall conform to its published specifications. With respect to all non-Seller Equipment, Seller gives no warranty, and only the warranty, if any, given by the manufacturer shall apply. Rechargeable batteries are excluded from this warranty but are warranted under a separate Rechargeable Battery Warranty (ECR-7048).
- B. Seller's obligations set forth in Paragraph C below shall apply only to failures to meet the above warranties occurring within the following periods of time from date of sale to the Buyer and are conditioned on Buyer's giving written notice to Seller within thirty (30) days of such occurrence:
1. for fuses and non-rechargeable batteries, operable on arrival only.
 2. for parts and accessories (except as noted in B.1), ninety (90) days.
 3. for XG-75, P7300, P7200, P7100^{IP}, P5500, P5400, P5300, P5200, P5100, P3300, M7300, M7200 (including V-TAC), M7100^{IP}, M5300 and M3300 radios, two (2) years, effective 10/01/2007.
 4. for Unity[®] XG-100P, three (3) years.
 5. for all other equipment of Seller's manufacture, one (1) year.
- C. If any Equipment fails to meet the foregoing warranties, Seller shall correct the failure at its option (i) by repairing any defective or damaged part or parts thereof, (ii) by making available at Seller's factory any necessary repaired or replacement parts, or (iii) by replacing the failed Equipment with equivalent new or refurbished Equipment. Any repaired or replacement part furnished hereunder shall be warranted for the remainder of the warranty period of the Equipment in which it is installed. Where such failure cannot be corrected by Seller's reasonable efforts, the parties will negotiate an equitable adjustment in price. Labor to perform warranty service will be provided at no charge during the warranty period only for the Equipment covered under Paragraph B.3 and B.4. To be eligible for no-charge labor, service must be performed at Seller's factory, by an Authorized Service Center (ASC) or other Servicer approved for these purposes either at its place of business during normal business hours, for mobile or personal equipment, or at the Buyer's location, for fixed location equipment. Service on fixed location equipment more than thirty (30) miles from the Service Center or other approved Servicer's place of business will include a charge for transportation.
- D. Seller's obligations under Paragraph C shall not apply to any Equipment, or part thereof, which (i) has been modified or otherwise altered other than pursuant to Seller's written instructions or written approval or, (ii) is normally consumed in operation or, (iii) has a normal life inherently shorter than the warranty periods specified in Paragraph B, or (iv) is not properly stored, installed, used, maintained or repaired, or, (v) has been subjected to any other kind of misuse or detrimental exposure, or has been involved in an accident.
- E. The preceding paragraphs set forth the exclusive remedies for claims based upon defects in or nonconformity of the Equipment, whether the claim is in contract, warranty, tort (including negligence), strict liability or otherwise, and however instituted. Upon the expiration of the warranty period, all such liability shall terminate. The foregoing warranties are exclusive and in lieu of all other warranties, whether oral, written, expressed, implied or statutory. **NO IMPLIED OR STATUTORY WARRANTIES OF MERCHANTABILITY OR FITNESS FOR PARTICULAR PURPOSE SHALL APPLY. IN NO EVENT SHALL THE SELLER BE LIABLE FOR ANY INCIDENTAL, CONSEQUENTIAL, SPECIAL, INDIRECT OR EXEMPLARY DAMAGES.**

This warranty applies only within the United States.

Harris Corporation
RF Communications Division
221 Jefferson Ridge Parkway
Lynchburg, VA 24501
1-800-368-3277

Harris Corporation
RF Communications Division
1680 University Avenue
Rochester, NY 14610
1-585-244-5830

ECR-7047M

