

**Cactus**

User Manual

**Manual  
Flash  
RF60**

## Table of Content

## 1. Getting to know RF60

Thank you for purchasing Cactus Wireless Flash RF60. The RF60 is a manual portable flash that allows you to command your lights off camera, with no wires. You can position your lights at any angle, direction and distance – the possibilities are endless!

- Built-in **Wireless Commander and Receiver**;
- **Remote Control** of Power levels and Zooms;
- **Group Control** up to 4 groups with configurable **Group Alias**;
- **Optical Slave** with **Delay** feature;
- **High Power** up to a Guide Number of 60 meters;
- **Compatible with Cactus V6** Wireless Flash Transceiver;
- **Multi-flash** feature;
- **High-speed Sympathy mode** provides HSS support when working with TTL flashes;

## 2. Caution and Warnings

Before using the product, read the following precautions to ensure correct and safe use and to help prevent damage of Cactus RF60.

1. Turn OFF all your equipments (Cactus units and cameras, etc.) before changing batteries or making connection.

2. Remove batteries and switch off the flash during storage.
3. Use only the batteries specified in this instruction manual;
4. Do not permanently store the product in a high temperature environment (i.e. under strong direct sunlight, near cooking stoves / oven).
5. Cactus RF60 should not be submerged in liquid or exposed to heavy rain unless it is properly protected.
6. Do not operate the device in the presence of flammable gases or fumes.
7. Do not fire the flash directly into the eyes of someone at close range.
8. Do not fire the flash directly at the driver of a moving car.

### 3. Major Specifications

- Guide Number (ISO 100) in meter:

Zoom (mm)	24	28	35	50	70	80	105
GN (meter)	33	34	38	45	53	57	60
GN (feet)	108	112	124	147	174	186	195

- Motor Zooms: 24mm – 28mm – 35mm – 50mm – 70mm – 80mm – 105mm
- Power levels (21 in total):

1/1	1/2	1/4	1/8	1/16	1/32	1/64	1/128
	1/2+0.3	1/4+0.3	1/8+0.3	1/16+0.3	1/32+0.3	1/64+0.3	1/128+0.3
	1/2+0.7	1/4+0.7	1/8+0.7	1/16+0.7	1/32+0.7	1/64+0.7	1/128+0.7

- Flash Durations: 1/300s – 1/20,000s
- Modes: Local (L), Master (M) and Slave (S)
- Working Radio Frequency: 2.4GHz
- Number of Channels: 16
- Number of Groups: 4
- Maximum Wireless Effective Distance: 200 meters

- Built in Optical Slave Mode: S1 (pre flash or main flash) / S2 (main flash only)
- Power input: 4x AA Batteries (LR6 alkaline or Ni-MH), rechargeable Ni-MH for best performance
- Flash count per battery cycle: 100-700 times (depends on power level)
- Recycle time: 0.1-5.0 seconds
- Color temperature: 5600k +/- 200k
- Operating temperature: -20°C to +50°C
- Dimensions: 205 x 83 x 61mm
- Net weight: 390g

### 4. Package Content

**Cactus RF50 Flash (1)**  
**Cactus Flash Stand FS-2 (1)**  
**Cactus Flash Carrying Case FC-3 (1)**  
**User Manual (1)**

(illustration T.B.A)

## 5. Nomenclature

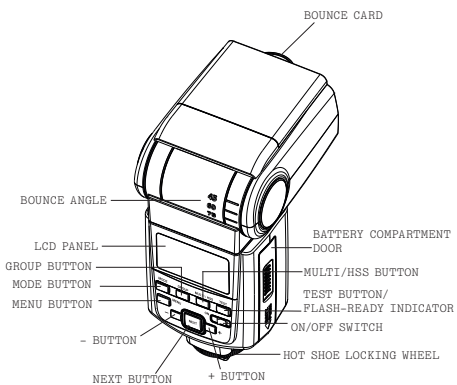
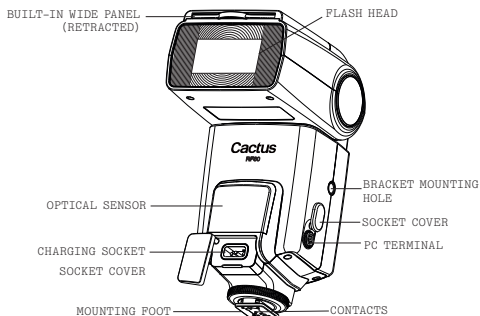

## 6. LCD Panel

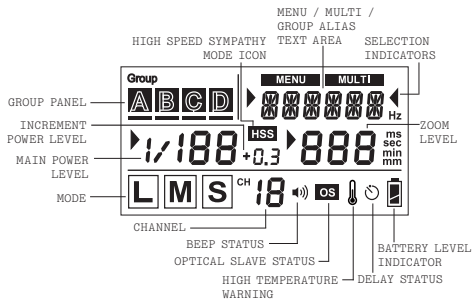

## 7. Getting Started

7.1

### Inserting Batteries

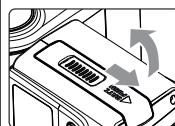

1. Open the cover.

Use your thumb to press the battery compartment door, and slide it as shown by the arrow to open the door.

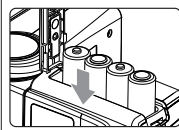

2. Install the batteries.  
Make sure the positive (+) and negative (-) battery contacts are properly oriented as shown in the compartment.

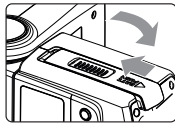

3. Close the cover.  
Slide the battery cover as shown by the arrow to close it.

**⚠ Caution**

1. Use a new set of AA batteries of the same brand. When replacing batteries, replacing all four at one time.
2. AA-sized alkaline, Ni-HM or lithium batteries can be used.
3. If you change batteries after firing many flashes continuously, be aware that the batteries may be hot.

### Attaching to the Camera

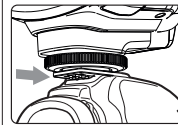

1. Attach the Flash.  
Slide the flash's hot shoe mounting foot into camera's hot shoe all the way.

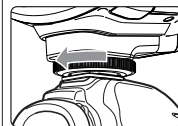

2. Secure the Flash.  
Rotate the locking wheel on the mounting foot until it locks up.

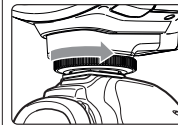

3. Detach the Flash.  
Rotate the locking wheel on the mounting foot until it is loosened.

## 7.3

## Turning on the Power Switch

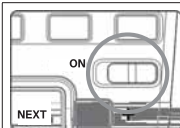

1. Switch the On/Off Switch to ON. Flash starts charging.

⚠ If a signal blinks on the LCD panel, the battery power is low and the flash stops charging. In this case, the zoom adjustment will be disabled. Please change the batteries immediately.

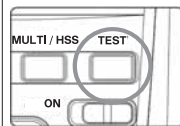

2. Check that the flash is ready.
  - The flash-ready indicator blinks in red, indicating that the flash is ready for quick flash (see Section 12.3).
  - Once fully charged, the flash-ready indicator will stay in red, and the flash is ready for giving full power output.
  - Press TEST button will fire a test flash.

### ⚠ Caution

1. When the flash is switched ON and the flash power is off automatically after a certain period of idle use, the flash still consumes power and power discharges for a long time may damage batteries. Therefore, shut off the flash power if the flash is not used for long periods of time. AA-sized alkaline, Ni-HM or lithium batteries can be used.
2. To avoid overheating and degrading the flash head, do not fire more than 20 continuous flashes. After 20 continuous flashes, allow a rest time for at least 10 minutes.

⚠ If you fire more than 20 continuous flashes in short intervals, the inner overheating prevention function may be activated to prolong the recycling time to about 8 – 20 seconds. The temperature warning signal would appear in the status bar of the LCD screen. If this occurs, allow a rest time of about 15 minutes, and the flash will then return to normal.

## 7.4

## Adjusting Flash Head

By pointing the flash towards a wall or ceiling, the flash will bounce off the surface before illuminating the subject. This can soften the shadows behind the subject for a more natural looking shot. This is called a bounce flash.

The flash head of RP60 can be tilted to an angle of 45°, 60°, 75° and 90° vertically. Horizontally, it can be rotated to 30°, 60°, 90°, 120°, 150°, 180° to the right and 30°, 60°, 90° to the left. Hold the flash head and turn it to a satisfying angle vertically and horizontally.

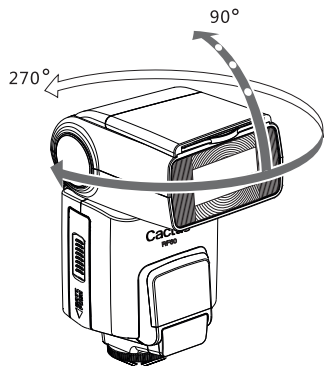

## 7.5

## Bounce Card and Wide Angle Diffuser

There is a set of bounce card and wide angle diffuser built-in RP60. Bounce card is useful for strengthening a bounce flash creating a catchlight, while wide angle diffuser can increase the flash light coverage to 14mm wide.

## Using Bounce Card

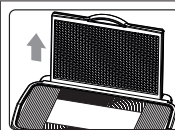

1. Point the flash head upward by 90°.
2. Pull out the wide angle diffuser, the bounce card will come out at the same time.

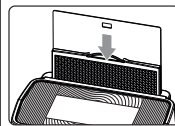

3. Push the wide angle diffuser back in, the bounce card will be ready for use.

## Using Wide Angle Diffuser

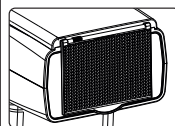

1. Pull out the wide angle diffuser and place it over the flash head as shown. The bounce card will come out at the same time.
2. Push the bounce card back in. The flash coverage will be illuminating at 14mm coverage.

## 8. On-camera Operation: Local Mode **L**

### 8.1

#### Choosing Local Mode

There are 3 operating modes in RF60, namely Local, Master and Slave. Upon switching on RF60, press the **[MODE]** button to choose the appropriate mode. The mode indicator turns in the following sequence.



To use RF60 on camera's hot shoe without wireless connection, switch RF60 to Local mode.

### 8.2

#### Adjusting Power and Zoom

In the main screen, the power level is shown on the left while the zoom right. The selection indicator ► will be shown at either the power level or zoom. Press the **[NEXT]** button to switch the selection indicator in order to adjust a setting of an item.

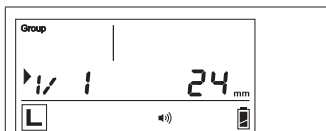

To adjust power, press **[NEXT]** until the selection indicator ► is pointing to power ratio value (i.e., the left figure in the central row), press + to increase or - to decrease the power level.

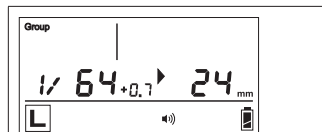

To adjust zoom, press **[NEXT]** until the selection indicator ► is pointing to the zoom value (i.e., the right figure at the centre row), press + to increase or - to decrease the zoom range.

The power levels available for adjustment are as below:

1/1	1/2	1/4	1/8	1/16	1/32	1/64	1/128
	1/2+0.3	1/4+0.3	1/8+0.3	1/16+0.3	1/32+0.3	1/64+0.3	1/128+0.3
	1/2+0.7	1/4+0.7	1/8+0.7	1/16+0.7	1/32+0.7	1/64+0.7	1/128+0.7

The power levels available for adjustment are as below:

Zoom (mm)	24	28	35	50	70	80	105
-----------	----	----	----	----	----	----	-----

## 9. Wireless Flash: Master and Slave Modes **M** **S**

With a built-in RF (Radio Frequency) module, the RF60 has the capability to communicate with other RF60 unit wirelessly. To control and fire RF60 wirelessly, set up one RF60 in Master mode and the other RF60 units in Slave mode.



## 9.1 Setting Up RF60 Slave

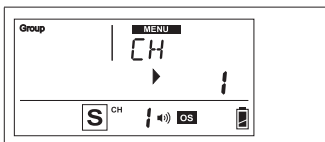

- Switch all off-camera RF60 units to **Slave mode** by pressing [MODE]. Each press of the button will change mode in the following sequence:  
Local → Master → Slave  
↑
- Set all RF60 to the same **channel**. Press [MENU], use + or - button to select the RF channel. Press [MENU] to go back to main screen. The selected channel will be shown at the bottom status bar.



- Assign RF60 Slave units to either group A, B, C or D. Press Group to select the [GROUP] for each RF60. Each press of the Group button in Slave mode will change group in the sequence of A-B-C-D. The selected group will be shown on the group panel.

## 9.2 Commanding with RF60 Master

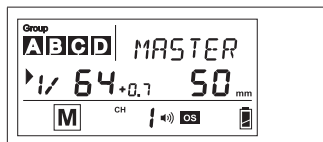

- Set the on-camera RF60 to **Master mode** by pressing [MODE] (see Section 9.1).
- Set RF60 Master to the same **channel** as RF60 Slave units (see Section 9.1).
- Check the group status on the group panel. Only activated group(s) will be shown as A, B, C or D boxes.
- On RF60 Master, you can change Power level and Zoom settings of the Master flash itself, and RF60 Slave flashes in A, B, C and D group.
- The default group is the Master RF60 itself. In the display, the text area will show <MASTER>. No group is selected in the group panel, though it still shows the group activation status.

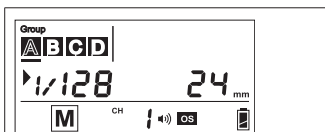

6. To select a particular group for remote control, press **[GROUP]** and the group selection indicator will go to group A.

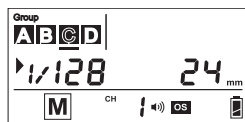

7. Press **[GROUP]** again will select next group, i.e., group B. Each press on the Group button will select next group in the following sequence:  
 Master → A → B → C → D
8. Adjust Power level of the Master flash or of a particular group using + or - button. Press **[NEXT]** to Zoom and adjust also with the + or - button.

**Note:** The power level and zoom settings will only apply to the group being selected.

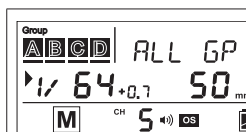

9. You may also change settings for all active groups at the same time. To select all groups, long press the **[GROUP]** button.
10. All selection indicators of the activated groups will be on and the text area will show <ALL GP>. The power level and zoom of the last group selected will be shown.
11. Adjust power level and zoom level as you do for a single group. The changes in both settings, however, will apply to all active groups, including the Master flash.
12. To exit from all group control, press **[GROUP]** button once.

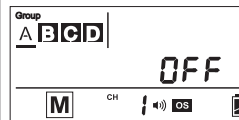

13. If you wish to stop firing a particular group, turn the group off by selecting the group (see step 2 and 3) and long pressing the **[NEXT]** button. The screen will show <OFF> in the centre row.

**Note:** The RF60 Master can also be turned off by long pressing the **[NEXT]** button in the Master group. Once turned off, the RF60 Master will not fire, but it would still command RF60 Slaves to change setting and fire accordingly.

14. To **turn on a group** again, select the group (see step 2 and 3) and long press the **[NEXT]** button. The power level and zoom setting of the group will be shown in the centre row again.

15. Press the shutter on camera and the RF60 Master and Slave units in A, B, C or D group will fire at the power level and zoom setting as you have set in the RF60 Master.

## 10. Group Aliases

The RF60 comes with a list of preset group alias for users to choose for the particular slave groups according to the purpose of each. The chosen group alias will be shown in the text area beside the group icons. The group alias will display whenever the group is selected.

The group aliases available for selection include:  
 KEY – FILL – SPOT – RIM – HAIR – LEFT  
 – RIGHT – BACK – FRONT

Group

1. To set group alias, select the group you would like to set an alias, then press the **[GROUP]** and **[MENU]** button simultaneously.
2. The selection indicator and group alphabet will be shown in the text area. Press + or – button to scroll through the group aliases available for selection.

Group

3. Press **[NEXT]** or **[MENU]** to confirm the alias and exit.
4. Repeat 1-3 to set aliases in all the Cactus RF60. To prevent confusion, make sure that you have set the same aliases for the same group in all RF60 units.



Power	Hz	10	11	12-14	15-19	20-50	60-199
1/4	2	2	2	2	2	2	2
1/8	4	4	4	4	4	4	4
1/16	8	8	8	8	8	8	8
1/32	20	20	20	18	16	12	
1/64	50	40	40	35	30	20	
1/128	70	70	60	50	40	40	

**⚠** To avoid overheating, do not use Multi Flash more than 10 times in succession. After using Multi Flash for 10 times, allow the flash to rest for at least 15 minutes. Overuse of Multi Flash may cause over-temperature warning to protect the flash head. In this case, the flash may stop firing until heat dissipates and temperature drops to a safe level.

#### Notes:

1. Multi flash is most effective with a highly reflective subject against a dark background.
2. Multi flash is not supported at power level higher than 1/4.
3. Multi flash can be used with bulb mode camera shutter.

#### 11.1.1 Multi Flash in Local Mode

Once you have determined the shutter speed, the number of flash and the frequency of flash, you can set up the flash in Multi mode.



1. To enter Multi Mode, press **[MULTI/HSS]** once and the LCD screen will show the Multi and Hz icons.
2. Press **[NEXT]** until the selection indicator **▶** points to the beginning of the text area. The value before the hyphen represents number of flashes in Multi mode.
3. Press **+** to increase or **-** to decrease the number of flashes.

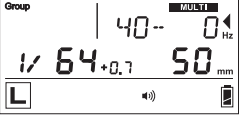

4. Press **[NEXT]** until the selection indicator **▶** points to the right of the text area. The value after the hyphen represents the flash frequency per second in Multi mode.
5. Press **+** to increase or **-** to decrease the flash frequency per second.

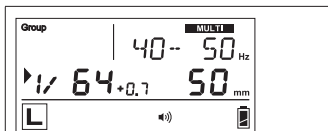

6. Press **[NEXT]** to adjust the Power level (see Section 8.1).
7. Press **[NEXT]** to adjust the Zoom (see Section 8.1).
8. To exit Multi mode, press **[MULTI/HSS]** twice to return to the main screen.

### 11.1.2 Multi Flash in Master and Slave Modes

When working wirelessly, the Multi flash setting of Slave RF60 will sync with the Master RF60 in the same channel.

1. To enter Multi mode in RF60 Master, press **[GROUP]** until you see <MASTER> displayed as the group name.
2. Press **[MULTI/HSS]** button once. The LCD of RF60 Master and Slave units will show the Multi and Hz icons. Both Master and Slave units are now in Multi Flash mode.
3. On RF60 Master, follow the steps in 11.1.1 to adjust the number of flashes and flash frequency per second (Hz). The flash frequency will apply to both Master and Slave units in all active groups. Whenever the number of flashes is larger than supported by the power level of a particular slave group (see table Maximum Number of Multi Flashes), it will be reduced accordingly.

4. Since Multi flashes are not supported in power levels higher than 1/4, the Slave RF60 set at those power levels will only flash once in Multi mode.
5. To exit Multi mode, press Group to Master, press **[MULTI/HSS]** button twice get return to normal flash mode.

#### Notes:

1. Multi mode and HSS mode (see Section 11.2) are exclusive options. Pressing the **[MULTI/HSS]** button changes the flash modes in the following sequence:  
Normal Flash → Multi Flash  
→ HSS Flash
2. On RF60 Master, the flash modes can only be selected in the Master group. The selection will apply to the RF60 Master and all RF60 Slaves in the active group(s).

## 11.2

### HSS Sympathy Mode **[HSS]**

RF60 is a manual flash that does not have TTL capability which often supports High Speed Sync, such as HSS mode on a Canon and FP mode, or Focal Plane Shutter, on the Nikon. However, the RF60 offers a HSS Sympathy Mode that can work with TTL portable flash to support High Speed Sync wirelessly.

In HSS Sympathy mode, RF60 will fire flashes at longer duration with even illuminations. Longer flash duration enables synchronization at shorter shutter speeds, i.e. the shutter speed shorter than the camera's x-sync speed.