

# HEALTHRIDER<sup>®</sup>

## 15.5 S

Model No. HCTL39607.0

Serial No. \_\_\_\_\_

Write the serial number in the space above for future reference.

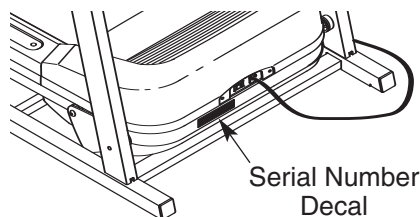

## USER'S MANUAL

### QUESTIONS?

As a manufacturer, we are committed to providing complete customer satisfaction. If you have questions, or if parts are damaged or missing, PLEASE CONTACT OUR CUSTOMER SERVICE DEPARTMENT DIRECTLY.

CALL TOLL-FREE:

**1-888-936-4266**

Mon.-Fri., 8:00 until 17:00 EST  
(excluding holidays)

OR E-MAIL US:

[customerservice@iconcanada.ca](mailto:customerservice@iconcanada.ca)

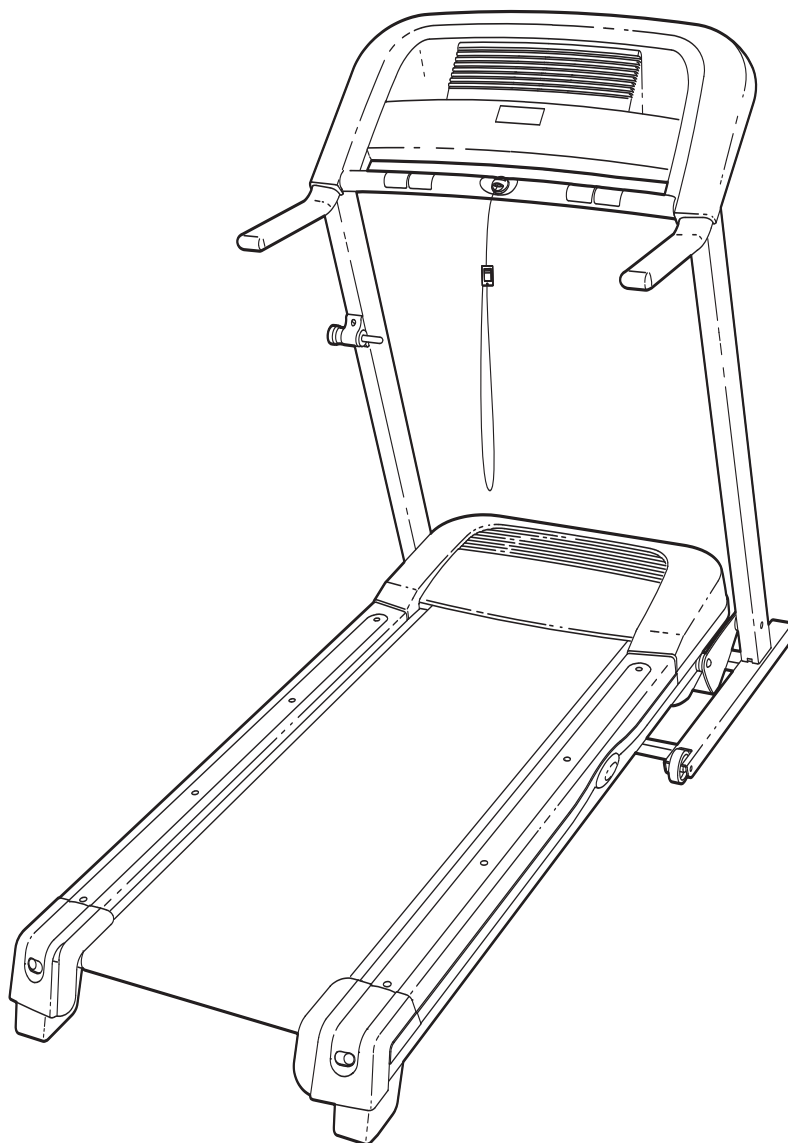

### CAUTION

Read all precautions and instructions in this manual before using this equipment. Save this manual for future reference.



Visit our website at

[www.healthrider.com](http://www.healthrider.com)

# TABLE OF CONTENTS

WARNING DECAL PLACEMENT .....2

IMPORTANT PRECAUTIONS .....3

BEFORE YOU BEGIN .....5

ASSEMBLY .....6

OPERATION AND ADJUSTMENT .....11

HOW TO FOLD AND MOVE THE TREADMILL .....18

TROUBLESHOOTING .....20

EXERCISE GUIDELINES .....22

PART LIST .....23

EXPLODED DRAWING .....24

ORDERING REPLACEMENT PARTS .....Back Cover

LIMITED WARRANTY .....Back Cover

## WARNING DECAL PLACEMENT

The decals shown here have been placed on the treadmill. **If a decal is missing or illegible, call the telephone number on the front cover of this manual and request a free replacement decal. Apply the decal in the location shown.** Note: The decals are not shown at actual size.

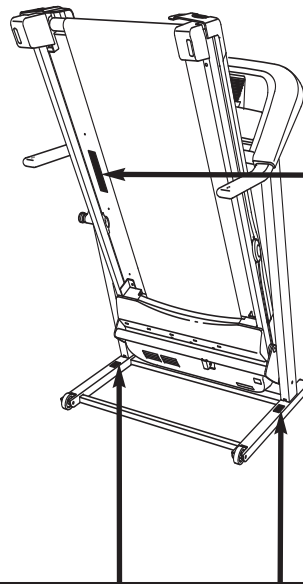

**! CAUTION ! ATTENTION**

KEEP HANDS AND FEET AWAY FROM THIS AREA WHILE THE TREADMILL IS IN OPERATION.

GARDEZ VOS PIEDS ET VOS MAINS ÉLOIGNÉS DE CET ENDROIT QUAND LE TAPIS ROULANT EST EN MARCHÉ.

**! WARNING:**

Protect yourself and others from risk of serious injury. Read the user's manual and :

-  •Stand only on the side rails when starting or stopping treadmill.
- Change speed in small increments.
- Hold handrails to prevent falling, and always wear the safety clip while operating treadmill.
- Stop if you feel faint, dizzy, or short of breath.
- Fully engage storage latch before treadmill is moved or stored.
- Reduce incline to its lowest level before folding treadmill into storage position.

-  •Never allow children on or around treadmill.
- Remove key when not in use.

-  •Keep clothing, fingers, and hair away from moving belt.
- Never try to adjust or fix the belt while it is moving.
- Always wear athletic shoes while operating treadmill.

# IMPORTANT PRECAUTIONS

**⚠ WARNING:** To reduce the risk of serious injury, read all important precautions and instructions in this manual and all warnings on your treadmill before using your treadmill. ICON assumes no responsibility for personal injury or property damage sustained by or through the use of this product.

1. Before beginning any exercise program, consult your physician. This is especially important for persons over the age of 35 or persons with pre-existing health problems.
2. It is the responsibility of the owner to ensure that all users of this treadmill are adequately informed of all warnings and precautions.
3. Use the treadmill only as described.
4. Place the treadmill on a level surface, with at least 8 ft. (2 m) of clearance behind it and 2 ft. (0.5 m) on each side. Do not place the treadmill on any surface that blocks air openings. To protect the floor or carpet from damage, place a mat under the treadmill.
5. Keep the treadmill indoors, away from moisture and dust. Do not put the treadmill in a garage or covered patio, or near water.
6. Do not operate the treadmill where aerosol products are used or where oxygen is being administered.
7. Keep children under the age of 12 and pets away from the treadmill at all times.
8. The treadmill should be used only by persons weighing 275 lbs. (125 kg) or less.
9. Never allow more than one person on the treadmill at a time.
10. Wear appropriate exercise clothes when using the treadmill. Do not wear loose clothes that could become caught in the treadmill. Athletic support clothes are recommended for both men and women. *Always wear athletic shoes. Never use the treadmill with bare feet, wearing only stockings, or in sandals.*
11. When connecting the power cord (see page 11), plug the power cord into a surge suppressor (not included) and plug the surge suppressor into a grounded circuit capable of carrying 15 or more amps. No other appliance should be on the same circuit. Do not use an extension cord.
12. Use only a single-outlet surge suppressor that meets all of the specifications described on page 11.
13. Failure to use a properly functioning surge suppressor could result in damage to the control system of the treadmill. If the control system is damaged, the walking belt may change speed, accelerate, or stop unexpectedly, which may result in a fall and serious injury.
14. Keep the power cord and the surge suppressor away from heated surfaces.
15. Never move the walking belt while the power is turned off. Do not operate the treadmill if the power cord or plug is damaged, or if the treadmill is not working properly. (See TROUBLESHOOTING on page 20 if the treadmill is not working properly.)
16. Read, understand, and test the emergency stop procedure before using the treadmill (see HOW TO TURN ON THE POWER on page 13).
17. Never start the treadmill while you are standing on the walking belt. Always hold the handrails while using the treadmill.
18. The treadmill is capable of high speeds. Adjust the speed in small increments to avoid sudden jumps in speed.
19. Never leave the treadmill unattended while it is running. Always remove the key and unplug the power cord when the treadmill is not in use.

20. The pulse sensor is not a medical device. Various factors, including the user's movement, may affect the accuracy of heart rate readings. The pulse sensor is intended only as an exercise aid in determining heart rate trends in general.
21. Do not attempt to raise, lower, or move the treadmill until it is properly assembled. (See ASSEMBLY on page 6, and HOW TO FOLD AND MOVE THE TREADMILL on page 18.) You must be able to safely lift 45 lbs. (20 kg) to raise, lower, or move the treadmill.
22. When folding or moving the treadmill, make sure that the storage latch is fully closed.
23. Inspect and properly tighten all parts of the treadmill regularly.
24. Never insert any object into any opening on the treadmill.
25. **DANGER:** Always unplug the power cord immediately after use, before cleaning the treadmill, and before performing the maintenance and adjustment procedures described in this manual. Never remove the motor hood unless instructed to do so by an authorized service representative. Servicing other than the procedures in this manual should be performed by an authorized service representative only.
26. This treadmill is intended for in-home use only. Do not use this treadmill in a commercial, rental, or institutional setting.

**SAVE THESE INSTRUCTIONS**

# BEFORE YOU BEGIN

Thank you for selecting the new HEALTHRIDER® 15.5 S treadmill. The 15.5 S treadmill combines advanced technology with innovative design to help you get the most from your exercise in the convenience of your home. And when you're not exercising, the 15.5 S treadmill can be folded up, requiring less than half the floor space of other treadmills.

**For your benefit, read this manual carefully before using the treadmill.** If you have questions after reading this manual, please see the front cover of this man-

ual. To help us assist you, note the product model number and serial number before contacting us. The model number and the location of the serial number decal are shown on the front cover of this manual.



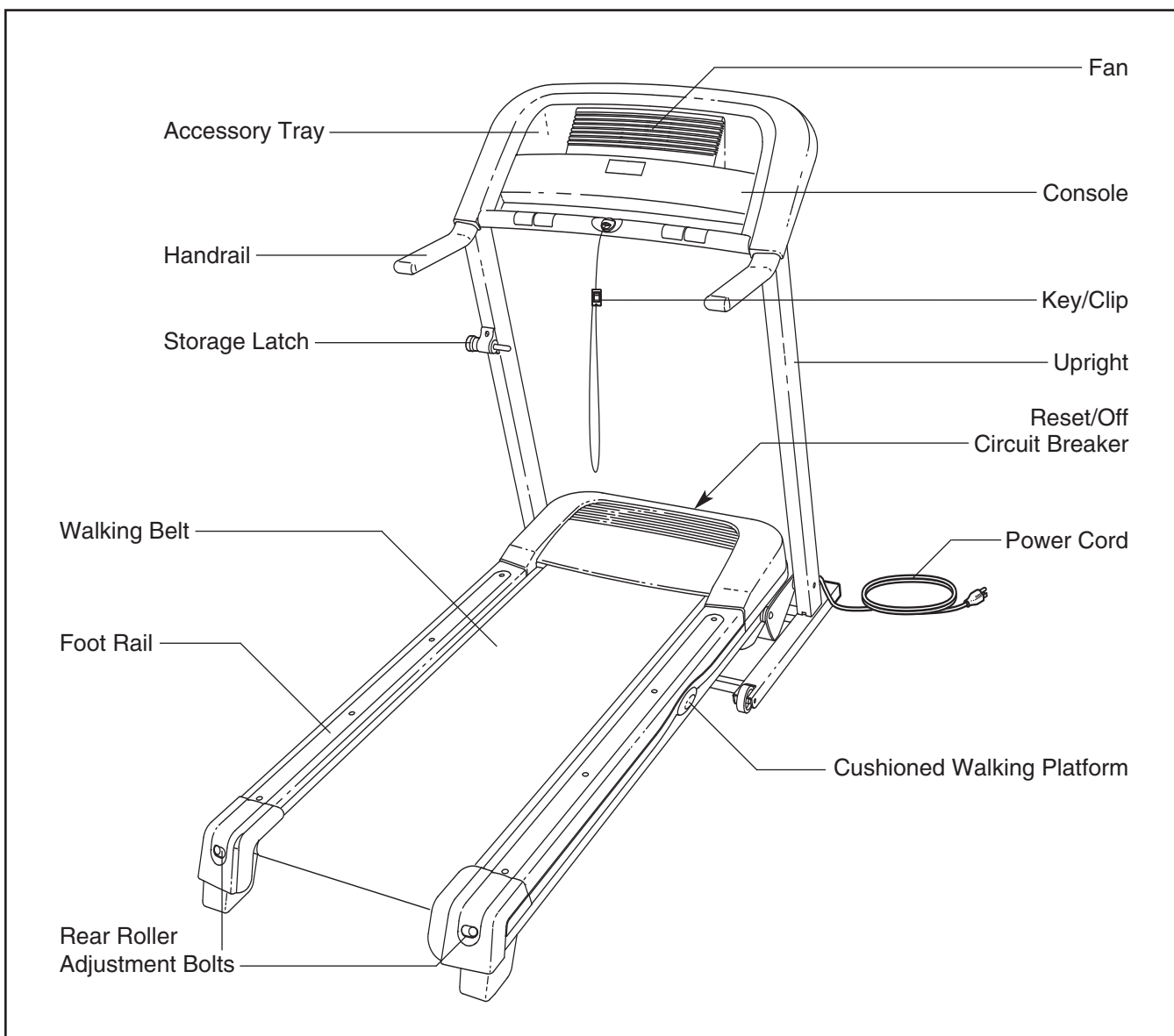

**To avoid a registration fee for any service needed under warranty, you must register the treadmill at [www.iconservice.com/registration](http://www.iconservice.com/registration).**

Before reading further, please review the drawing below and familiarize yourself with the labeled parts.



# ASSEMBLY

**Assembly requires two persons.** Set the treadmill in a cleared area and remove the packing materials; do not dispose of the packing materials until assembly is completed. Note: The underside of the treadmill walking belt is coated with high-performance lubricant. During shipping, lubricant may be transferred to the top of the walking belt or to the shipping carton. This is a normal condition and does not affect treadmill performance. If there is lubricant on top of the walking belt, wipe it off with a soft cloth and mild, non-abrasive cleaner.

**Assembly requires the included hex keys**  **and your own Phillips screwdriver**  , **rubber mallet**  , **adjustable wrench**  , and **wire cutters**  .

To identify assembly hardware, see the drawings below. The number in parentheses below each drawing is the key number of the part, from the PART LIST near the end of the manual. The number following the parentheses is the quantity used in assembly. **To avoid damaging plastic parts, do not use power tools for assembly.**

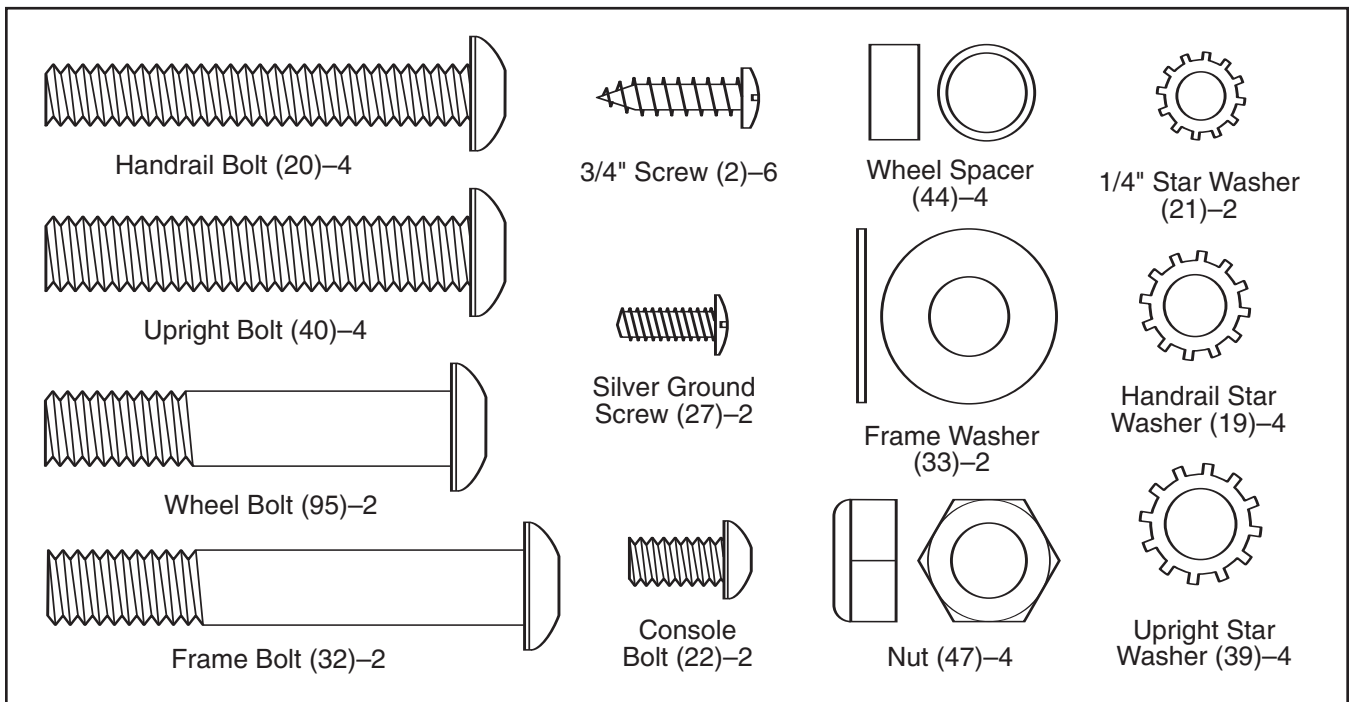

1. Orient the Base (48) as shown.

Identify the Right Upright (36), which has a square hole near the lower end.

Orient the Right Upright (36) as shown, and attach it to the Base (48) with two Upright Bolts (40) and two Upright Star Washers (39); **do not tighten the Upright Bolts yet.**

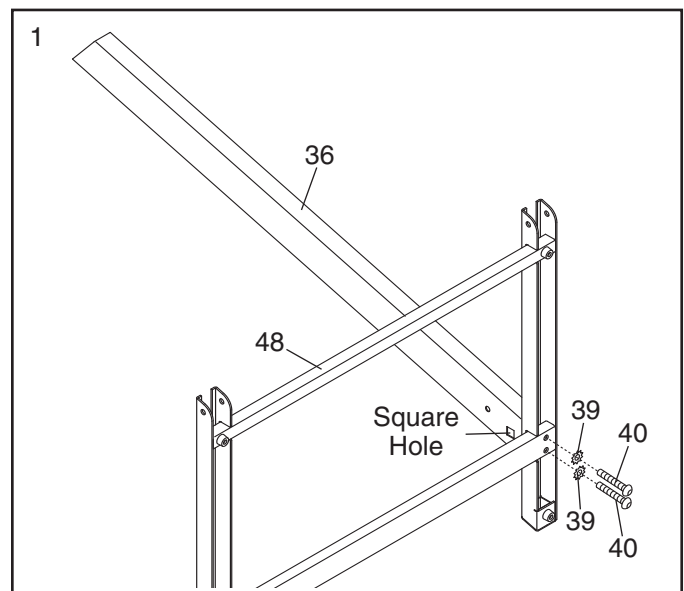

- Orient the Left Upright (31) as shown, and attach it to the Base (48) with two Upright Bolts (40) and two Upright Star Washers (39); **do not tighten the Upright Bolts yet.**

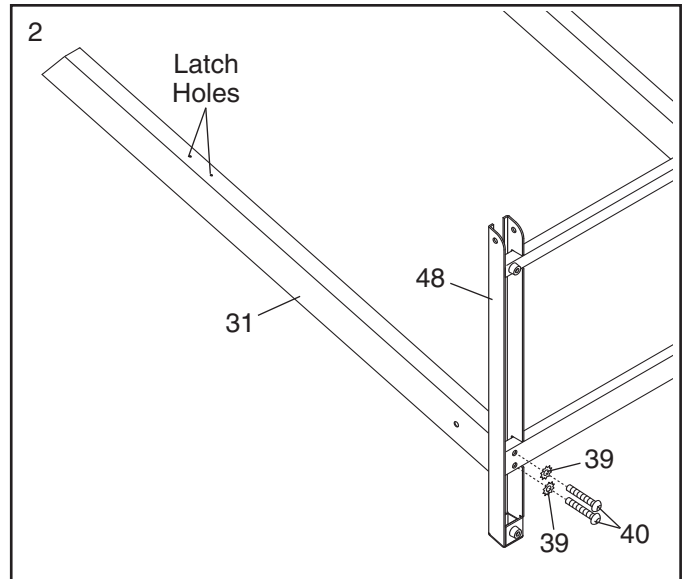

- Attach a Wheel (45) to each side of the Base (48) with a Wheel Bolt (95), two Wheel Spacers (44), and a Nut (47) as shown. **Do not over-tighten the Wheel Bolts; the Wheels should turn freely.**

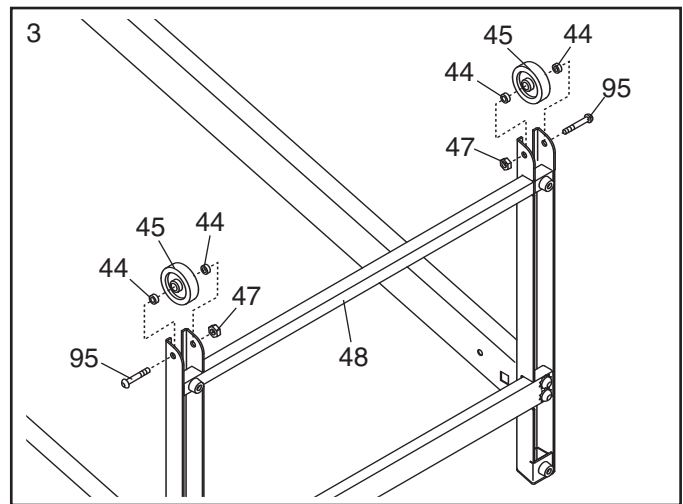

- Raise the Uprights (31, 36) so that the Base (48) is flat on the floor and positioned as shown.

Cut the tie holding the Upright Wire (28) in a bundle.

**See the far right drawing.** Wrap the wire tie in the Right Upright (36) around the end of the Upright Wire (28). Then, pull the other end of the wire tie until the Upright Wire is extending from the upper end of the Right Upright.

**Make sure that the end of the Upright Wire (28) does not fall into the Right Upright (36).**

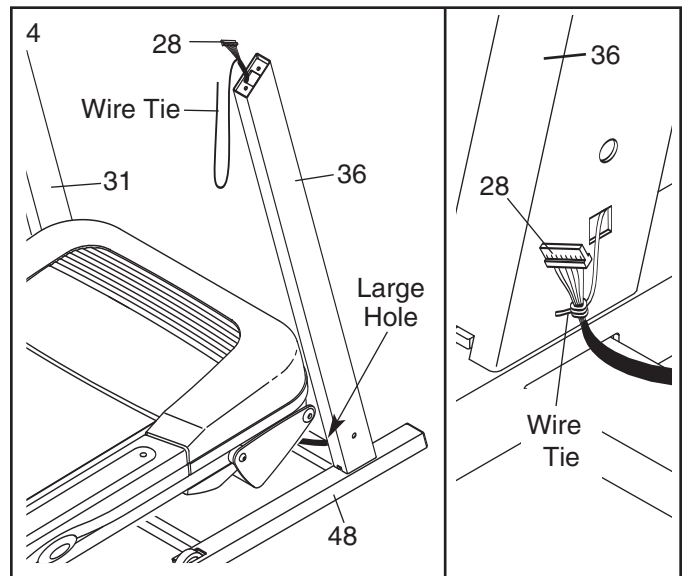

5. Raise the Uprights (31, 36).

**See the left inset drawing.** Identify the two Frame Spacers (34). Open the included packet of grease, and apply grease to both sides of both Frame Spacers. Then, identify the outer side of each Frame Spacer.

Hold a Frame Spacer (34) between the Right Upright (36) and the Lift Frame (59), with the **outer side of the Frame Spacer facing the Right Upright**. Attach the Right Upright to the Lift Frame with a Frame Bolt (32), a Frame Washer (33), and a Nut (47); **do not tighten the Frame Bolt yet.**

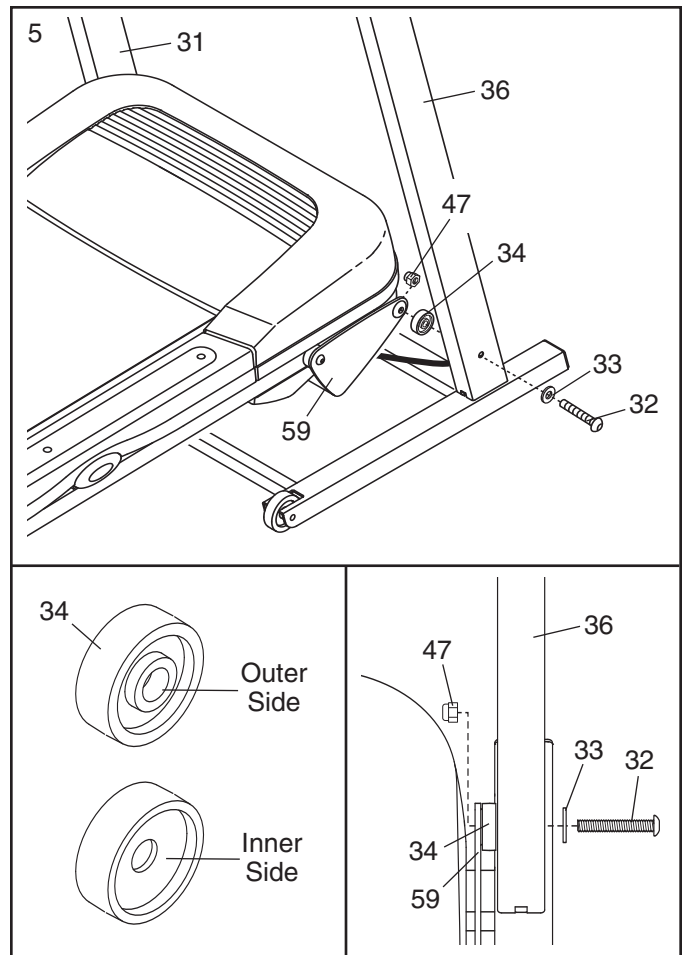

6. **See the left inset drawing.** Identify the outer side of the remaining Frame Spacer (34).

Hold the Frame Spacer (34) between the Left Upright (31) and the Lift Frame (59), with the **outer side of the Frame Spacer facing the Left Upright**. Attach the Left Upright to the Lift Frame with a Frame Bolt (32), a Frame Washer (33), and a Nut (47); **do not tighten the Frame Bolt yet.**

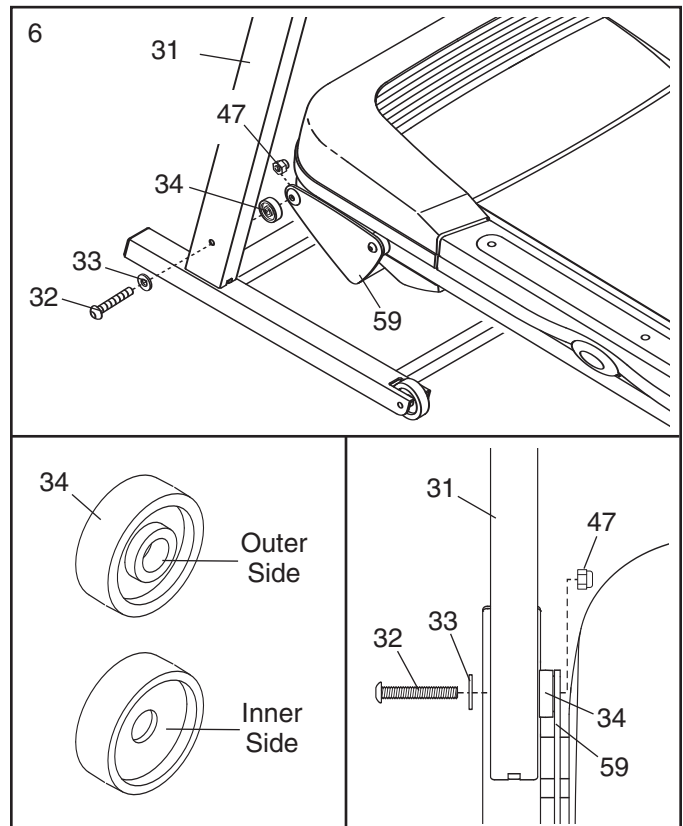



7. Route the Upright Wire (28) through one of the Handrails (18) as shown, and remove the wire tie from the Upright Wire.

Attach the Handrail (18) to the Right Upright (36) with two Handrail Bolts (20) and two Handrail Star Washers (19). **Be careful not to pinch the Upright Wire (28).**

Attach the other Handrail (18) to the Left Upright (31) with two Handrail Bolts (20) and two Handrail Star Washers (19).

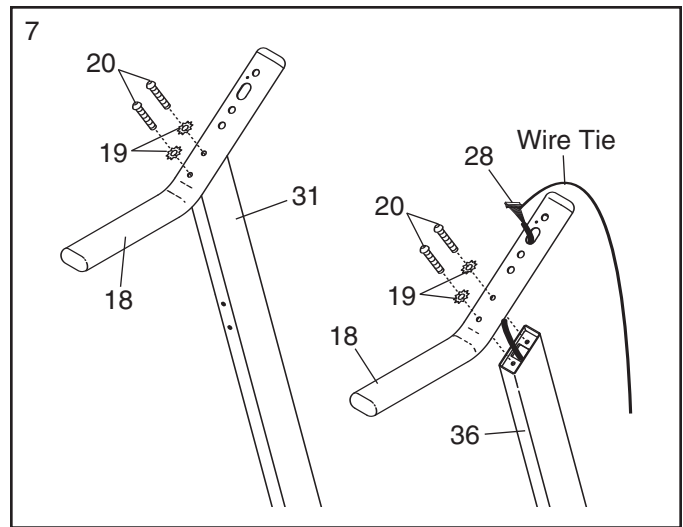

8. While another person holds the Console Base (26) near the right Handrail (18), attach the ground wire on the Console Base to the right Handrail with a Silver Ground Screw (27).

Connect the wire harness on the Console Base (26) to the Upright Wire (28) as shown in the inset drawing. **If the connectors are oriented correctly, they will slide together easily and snap into place.** If it does not, turn the end of the Wire Harness and then insert it. **IF THE CONNECTOR IS NOT INSERTED PROPERLY, THE CONSOLE MAY BE DAMAGED WHEN THE POWER IS TURNED ON.**

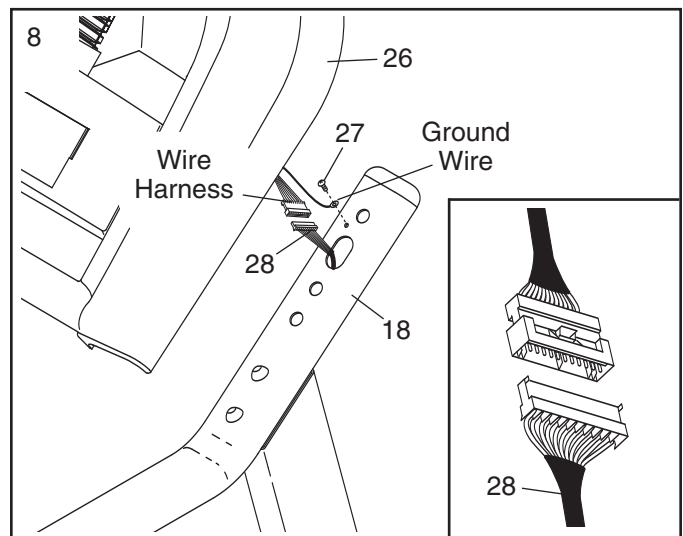

9. Insert the wires into the Console Base (26) as you set the Console Base on the Handrails (18). **Be careful not to pinch the wires.** Next, thread two Console Bolts (22) with 1/4" Star Washers (21) into the Handrails and the Console Base; **do not tighten the Console Bolts yet.**

Attach the Console Base (26) to the Handrails (18) with four 3/4" Screws (2). **Then, tighten the two Console Bolts (22).**

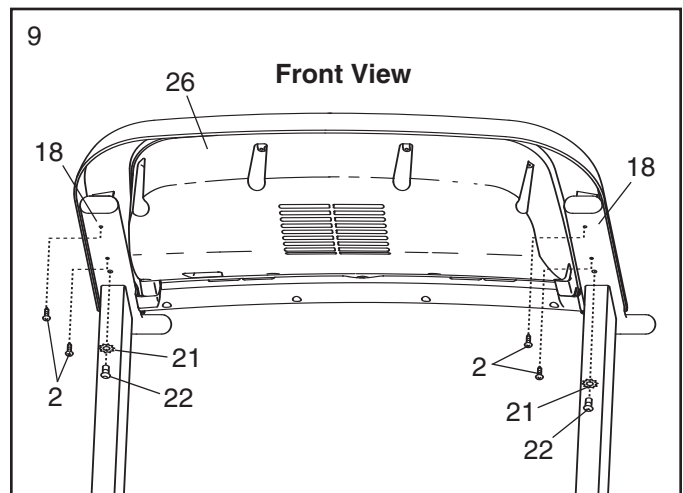

10. Lower the Uprights (31, 36) as shown.

**See the inset drawing.** Position the Uprights (31, 36) so that the treadmill Frame (74) is centered between the Uprights.

Firmly tighten the Frame Bolts (32) and then the Upright Bolts (40) on each side of the treadmill.  
**Do not overtighten the Frame Bolts.**

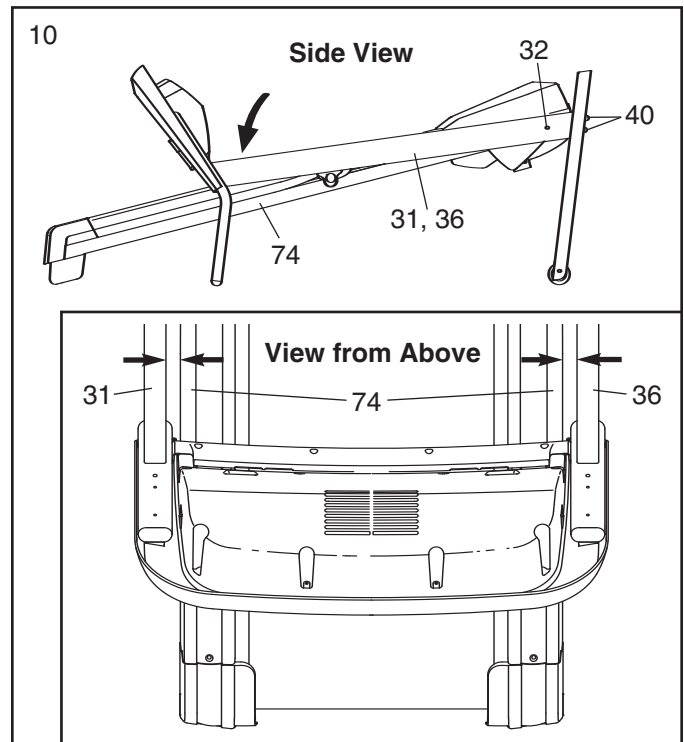

11. Attach the ground wire on the Upright Wire (28) to the indicated hole in the Base (48) with a Silver Ground Screw (27).

Press the indicated grommet into the Right Upright (36).

Raise the Uprights (31, 36).

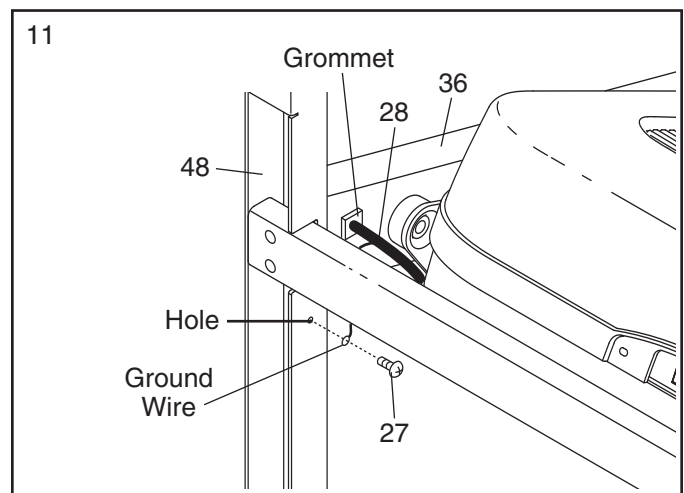

12. Attach the Latch Housing (30) to the Left Upright (31) with two 3/4" Screws (2). **Make sure that the large hole in the Latch Housing is on the side shown. Do not overtighten the Screws.**

Remove the knob from the pin. Make sure that the collar and the spring are on the pin as shown. Insert the pin into the Latch Housing (30), and tighten the knob back onto the pin.

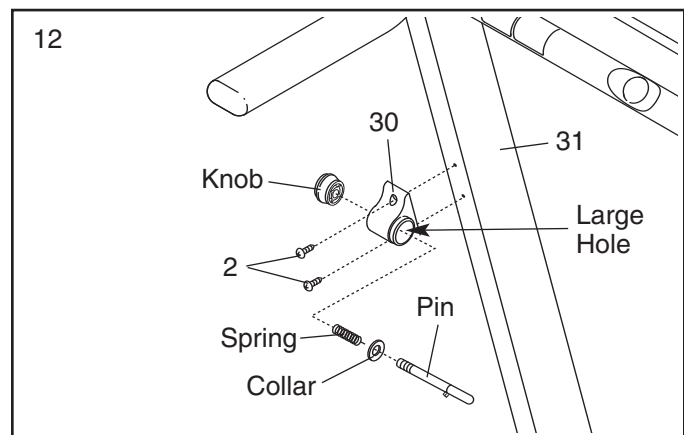

13. **Make sure that all parts are properly tightened before you use the treadmill.** Note: Extra hardware may be included. Keep the included hex keys in a secure place; the large hex key is used to adjust the walking belt (see page 21). To protect the floor or carpet, place a mat under the treadmill.

# OPERATION AND ADJUSTMENT

## THE PRE-LUBRICATED WALKING BELT

Your treadmill features a walking belt coated with high-performance lubricant. **IMPORTANT: Never apply silicone spray or other substances to the walking belt or the walking platform. Such substances will deteriorate the walking belt and cause excessive wear.**

## HOW TO PLUG IN THE POWER CORD

**⚠ DANGER:** Improper connection of the equipment-grounding conductor can result in an increased risk of electric shock. Check with a qualified electrician or serviceman if you are in doubt as to whether the product is properly grounded. Do not modify the plug provided with the product—if it will not fit the outlet, have a proper outlet installed by a qualified electrician.

Your treadmill, like any other type of sophisticated electronic equipment, can be seriously damaged by sudden voltage changes in your home's power. Voltage surges, spikes, and noise interference can result from weather conditions or from other appliances being turned on or off. **To decrease the possibility of your treadmill being damaged, always use a surge suppressor with your treadmill (see drawing 1 at the right).**

Use only a single-outlet surge suppressor that is UL 1449 listed as a transient voltage surge suppressor (TVSS). The surge suppressor must have a UL suppressed voltage rating of 400 volts or less and a minimum surge dissipation of 450 joules. The surge suppressor must be electrically rated for 120 volts AC and 15 amps. There must be a monitoring light on the surge suppressor to indicate whether it is functioning properly. Failure to use a properly functioning surge suppressor could result in damage to the control system of the treadmill. If the control system is damaged, the walking belt may change speed, accelerate or stop unexpectedly, which may result in a fall and serious injury.

**This product must be grounded.** If it should malfunction or break down, grounding provides a path of least resistance for electric current to reduce the risk of electric shock. This product is equipped with a cord having an equipment-grounding conductor and a grounding plug. **Plug the power cord into a surge suppressor, and plug the surge suppressor into an appropriate**

**outlet that is properly installed and grounded in accordance with all local codes and ordinances. Important: The treadmill is not compatible with GFCI-equipped outlets.**

This product is for use on a nominal 120-volt circuit, and has a grounding plug that looks like the plug illustrated in drawing 1 below. A temporary adapter that looks like the adapter illustrated in drawing 2 may be used to connect the surge suppressor to a 2-pole receptacle as shown in drawing 2 if a properly grounded outlet is not available.

The temporary adapter should be used only until a properly grounded outlet (drawing 1) can be installed by a qualified electrician.

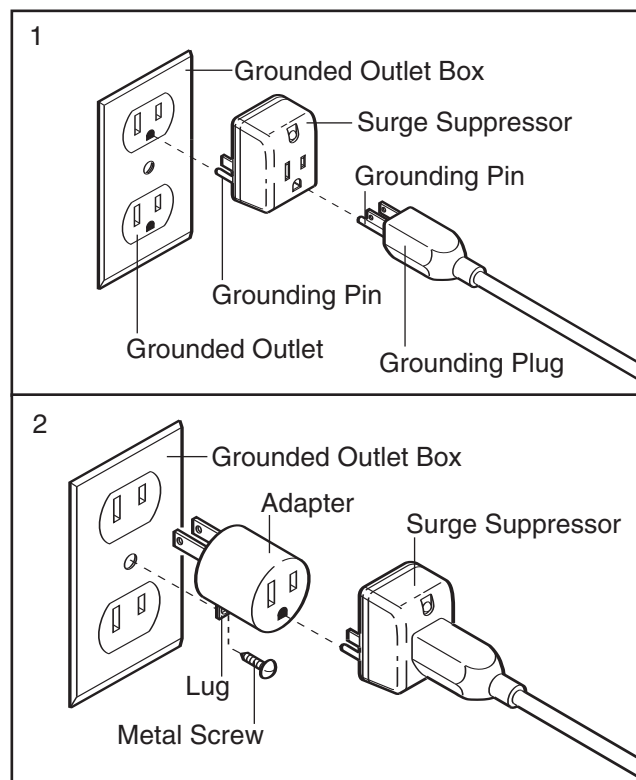

The green-colored rigid ear, lug, or the like extending from the adapter must be connected to a permanent ground such as a properly grounded outlet box cover. Whenever the adapter is used it must be held in place by a metal screw. **Some 2-pole receptacle outlet box covers are not grounded. Contact a qualified electrician to determine if the outlet box cover is grounded before using an adapter.**

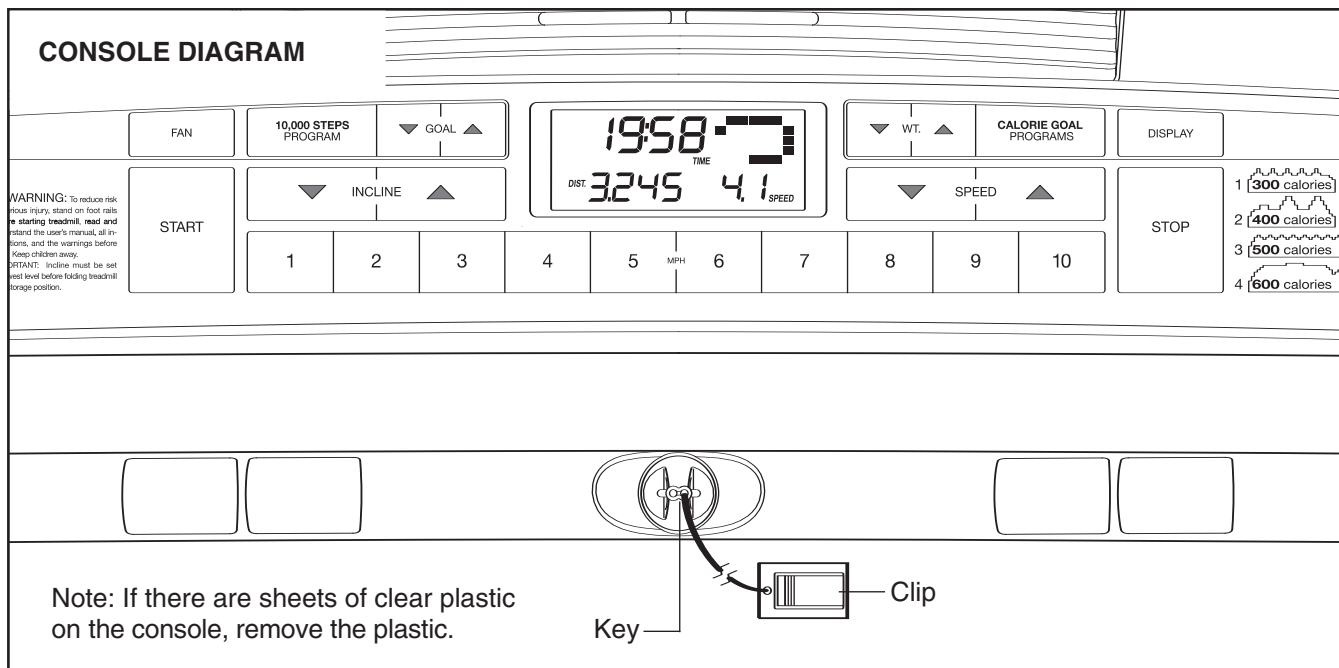

## FEATURES OF THE CONSOLE

The treadmill console offers a selection of features designed to make your workouts more effective. When the manual mode of the console is selected, the speed and incline of the treadmill can be changed with the touch of a button. As you exercise, the console will display continuous exercise feedback. You can even measure your heart rate using the built-in pulse sensor.

### Step Program

Walking is one of the most popular exercises worldwide. Walking does not require advanced conditioning or special skills, yet it produces numerous benefits, such as increased calorie burning, a slimmer waist, toned muscles, enhanced energy and stamina, lower blood pressure, and reduced stress.

To track your walking exercise, the console features a new step program that counts the number of steps that you take during each workout. In addition, the console offers a step program that allows you to enter the number of steps that you plan to walk, and counts down the steps as you exercise.

More reliable than conventional pedometers, the treadmill's step program is highly accurate with most users.

For the best results, try to maintain a steady pace, a uniform stride length, and a consistent position on the treadmill as you walk. Lighter users may also find it helpful to reduce the incline of the treadmill or to increase the speed of the walking belt.

### Calorie Goal Programs

The console also features four calorie goal programs. Each program controls the speed and incline of the treadmill to help you burn unwanted pounds.

**To use the manual mode of the console**, follow the steps beginning on page 13. **To use a step program**, see page 15. **To use a calorie goal program**, see page 16.

**IMPORTANT: To prevent damage to the walking platform, wear clean athletic shoes while using the treadmill. The first time you use the treadmill, observe the alignment of the walking belt, and center the walking belt if necessary (see page 21).**

Note: The console can display speed and distance in either miles or kilometers (see THE INFORMATION MODE on page 17). For simplicity, all instructions in this section refer to miles.

## HOW TO TURN ON THE POWER

**IMPORTANT:** If the treadmill has been exposed to cold temperatures, allow it to warm to room temperature before turning on the power. If you do not do this, the console displays or other electrical components may become damaged.

Plug in the power cord (see page 11). Next, locate the reset/off circuit breaker on the treadmill frame near the power cord. Switch the circuit breaker to the reset position.

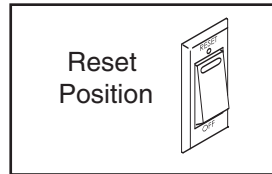

**IMPORTANT:** The console features a display demo mode, designed to be used if the treadmill is displayed in a store. If the displays light as soon as you plug in the power cord and switch the circuit breaker to the reset position, the demo mode is turned on. To turn off the demo mode, hold down the Stop button for a few seconds. If the displays remain lit, see **THE INFORMATION MODE** on page 17 to turn off the demo mode.

Next, stand on the foot rails of the treadmill. Find the clip attached to the key (see the drawing on page 12) and slide the clip onto the waistband of your clothes. Then, insert the key into the console. After a moment, the displays will light. **IMPORTANT:** In an emergency situation, the key can be pulled from the console, causing the walking belt to slow to a stop. Test the clip by carefully taking a few steps backward; if the key is not pulled from the console, adjust the position of the clip.

## HOW TO USE THE MANUAL MODE

### 1. Insert the key into the console.

See HOW TO TURN ON THE POWER above.

### 2. Enter your weight if desired.

For the most accurate calorie count, enter your weight into the console by pressing the weight (WT.) increase and decrease buttons repeatedly. Note: Once you have entered your weight, your weight will be saved in memory.



### 3. Select the manual mode.

When the key is inserted, the manual mode will be selected. If a program has been selected, press the Calorie Goal Programs button repeatedly until a track appears in the display.

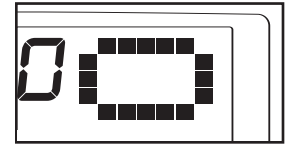

### 4. Start the walking belt.

To start the walking belt, press the Start button, the Speed increase button, or one of the buttons numbered 1 through 10.

If the Start button or the Speed increase button is pressed, the walking belt will begin to move at 1 mph. As you exercise, change the speed of the walking belt as desired by pressing the Speed increase and decrease buttons. Each time a button is pressed, the speed setting will change by 0.1 mph; if a button is held down, the speed setting will change in increments of 0.5 mph.

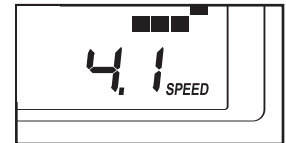

If one of the ten numbered buttons is pressed, the walking belt will gradually increase in speed until it reaches the selected speed setting.

To stop the walking belt, press the Stop button. The time will begin to flash in the display. To restart the walking belt, press the Start button, the Speed increase button, or one of the ten numbered buttons.

### 5. Change the incline of the treadmill as desired.

To change the incline of the treadmill, press the Incline increase and decrease buttons. Each time a button is pressed, the incline setting will change by 0.5%; if a button is held down, the incline setting will change quickly.

## 6. Follow your progress with the display.

When the manual mode or a step program is selected, a track representing 1/4 mile will appear in the upper right corner of the display. As you walk or run on the treadmill, the indicators around the track will appear in succession until the entire track appears. The track will then disappear and the indicators will again begin to appear in succession.

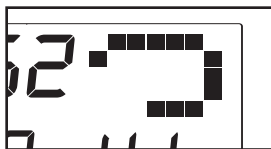

The lower left corner of the display can show the elapsed time, the distance that you have walked or run during your workout, and the incline level of the treadmill. Note: During a calorie goal program, the display will show the time remaining in the program instead of the elapsed time.



The lower right corner of the display can show the speed of the walking belt and the approximate number of calories that you have burned during your workout. The lower right corner of the display will also show your heart rate when you use the handgrip pulse sensor.

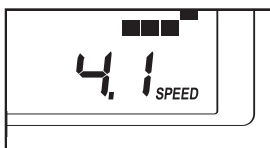

The upper display can show the elapsed time, the speed of the walking belt, the approximate number of calories that you have burned, the number of steps you have walked or run during your workout, or the distance that you have walked or run. Press the Display button repeatedly until the upper display shows the information that you are most interested in viewing. Note: When a step program is selected, the display will show the number of steps still to be taken instead of the number of steps you have walked or run.



While information is shown in the upper display, the same information will not be shown in the lower left or lower right display.

Note: For the treadmill to count your steps accurately, correct walking form is important. As you

walk, try to maintain a steady pace, a uniform stride length, and a consistent position on the treadmill. Lighter users may also find it helpful to reduce the incline of the treadmill or to increase the speed of the walking belt. **IMPORTANT: Always walk at a speed that is comfortable for you.**

To reset the display, press the Stop button, remove the key, and then reinsert the key.

## 7. Measure your heart rate if desired.

Before using the handgrip pulse sensor, remove the sheets of clear plastic from the metal contacts. In addition, make sure that your hands are clean.

To measure your heart rate, **stand on the foot rails** and place your hands on the metal contacts—**avoid moving your hands.**

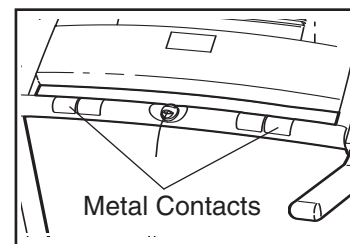

When your pulse is detected, the heart symbol in the display will begin to flash each time your heart beats, one or two dashes will appear, and then your heart rate will be shown. **For the most accurate heart rate reading, continue to hold the contacts for about 15 seconds.**

## 8. Turn on the fan if desired.

The fan features low and high speed settings. Press the fan button repeatedly to select a fan speed or to turn off the fan. Note: If the fan is on when the walking belt is stopped, the fan will turn off automatically after a few minutes.

## 9. When you are finished exercising, remove the key from the console.

Step onto the foot rails, press the Stop button, and **adjust the incline of the treadmill to the lowest setting. The incline must be at the lowest setting or you may damage the treadmill when you fold it to the storage position.** Next, remove the key from the console and put it in a secure place.

When you are finished using the treadmill, switch the reset/off circuit breaker to the "off" position and unplug the power cord. **IMPORTANT: If you do not do this, the treadmill's electrical components may wear prematurely.**



## HOW TO USE A STEP PROGRAM

### 1. Insert the key into the console.

See HOW TO TURN ON THE POWER on page 13.

### 2. Select a step program.

To select a step program, press the 10,000 Steps Program button or the Goal increase button; if you press the 10,000 Steps Program button, a goal of 10,000 steps will appear in the upper display. Note: If the walking belt is moving when the 10,000 Steps Program button is pressed, the walking belt will slow to a stop.



Depending on your fitness level, you may desire to walk fewer than or more than 10,000 steps. To change the goal, press the Goal increase and decrease buttons. Each time a button is pressed, the goal will change by 500 steps. Note: The goal can be changed either before or after the program is started.

Note: To find an appropriate starting goal, walk on the treadmill with the manual mode selected (see page 13), and note the number of steps that you walk during your workout. Then, round that number up to the nearest 500 steps. This can be a starting goal. As your fitness level improves, you can increase the goal by 500 steps every few weeks.

**IMPORTANT: Always exercise at an intensity level and for a length of time that is comfortable for you.**

### 3. Press the Start button or the Speed increase button to start the program.

A moment after the button is pressed, the walking belt will begin to move at 2 mph. Hold the handrails and begin walking.

As you exercise, adjust the speed and incline of the treadmill as desired by pressing the Speed and Incline buttons.

During the program, the upper display will show the number of steps still to be taken (unless you have changed the display by pressing the Display button). When only ten steps remain, the upper left of the display will flash and a tone will sound repeatedly until you reach the goal. The walking belt will then slow to a stop.

To stop the program temporarily, press the Stop button. The time will begin to flash in the display. To restart the program, press the Start button or the Speed increase button. The walking belt will begin to move at 2 mph. To end the program, press the Stop button, remove the key, and then reinsert the key.

### 4. Follow your progress with the display.

See step 6 on page 14.

### 5. Measure your heart rate if desired.

See step 7 on page 14.

### 6. Turn on the fan if desired.

See step 8 on page 14.

### 7. When you are finished exercising, remove the key from the console.

See step 9 on page 14.

## HOW TO USE A CALORIE GOAL PROGRAM

### 1. Insert the key into the console.

See HOW TO TURN ON THE POWER on page 13.

### 2. Enter your weight.

See step 2 on page 13. **Note: Always enter your weight before using a calorie goal program; the speed and incline settings of the program will depend on the weight setting you enter.**

### 3. Select a calorie goal program.

To select a calorie goal program, press the Calorie Goal Programs button repeatedly. As each calorie goal program is selected, the maximum speed setting of the program and the maximum incline setting of the program will flash in the display for a few seconds. The display will then show how long the program will last. A profile of the speed settings of the program will scroll across the display.



### 4. Press the Start button to start the program.

A moment after the button is pressed, the treadmill will automatically adjust to the first speed and incline settings of the program. Hold the handrails and begin walking.

Each program is divided into 30 or 40 one-minute segments. One speed setting and one incline setting are programmed for each segment. Note: The same speed and/or incline setting may be programmed for two or more consecutive segments.

During the workout, the profile will show your progress. The flashing segment of the profile represents the current segment of the workout.

The height of the flashing segment indicates the

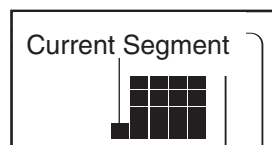

speed setting for the current segment. At the end of each segment, a series of tones will sound and the next segment of the profile will begin to flash. If a different speed and incline setting is programmed for the next segment, the speed or incline setting will flash in the display to alert you.

The workout will continue in this way until the last segment of the profile flashes in the display and the last segment ends. The walking belt will then slow to a stop.

If the speed or incline setting for the current segment is too high or too low, you can manually override the setting by pressing the Speed and Incline buttons. Every few times a Speed button is pressed, an additional indicator will appear or disappear in the Current Segment column. **Important: When the current segment of the program ends, the treadmill will automatically adjust to the speed and incline settings for the next segment.**

To stop the program at any time, press the Stop button. To restart the program, press the Start button or the Speed increase button. The walking belt will begin to move at 1 mph. When the next segment of the program begins, the treadmill will automatically adjust to the speed and incline settings for that segment.

The program will continue in this way until the last segment of the program ends. The walking belt will then slow to a stop. **Important: The calorie goal is an estimate of the number of calories that you will burn during the program. The actual number of calories that you burn will depend on your weight. In addition, if you manually change the speed or incline of treadmill during the program, the number of calories you burn will be affected.**



**5. Follow your progress with the display.**

See step 6 on page 14.

**6. Measure your heart rate if desired.**

See step 7 on page 14.

**7. Turn on the fan if desired.**

See step 8 on page 14.

**8. When you are finished exercising, remove the key from the console.**

See step 9 on page 14.

## THE INFORMATION MODE

The console features an information mode that keeps track of treadmill usage information and allows you to select a unit of measurement for the console.

To select the information mode, insert the key into the console while holding down the Stop button, and then release the Stop button. When the information mode is selected, the following information will be shown:

An “E” (for English miles) or an “M” (for metric kilometers) will appear in the lower right corner of the display. Press the Speed increase button to change the unit of measurement, if desired.

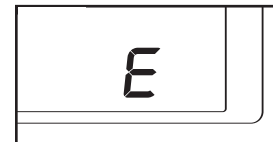

Note: The console features a display demo mode, designed to be used if the treadmill is displayed in a store. While the demo mode is turned on, the console will function normally when you plug in the power cord, switch the circuit breaker to the reset position, and insert the key into the console. However, when you remove the key, the displays will remain lit, although the buttons will not function. If the demo mode is turned on, a “d” will appear in the lower right display while the information mode is selected. To turn on or off the demo mode, press the Speed decrease button.

The upper left corner of the display will show the total number of **thousands** of steps taken by all users of the treadmill. For example, the number 396 would indicate 396,000 steps taken.



The lower left corner of the display will show the total number of hours that the treadmill has been used and the total number of miles (or kilometers) that the walking belt has moved, for a few seconds at a time.



To exit the information mode, remove the key from the console.

# HOW TO FOLD AND MOVE THE TREADMILL

## HOW TO FOLD THE TREADMILL FOR STORAGE

Before folding the treadmill, adjust the incline to the lowest position. If you do not do this, you may permanently damage the treadmill. Next, unplug the power cord.

**CAUTION:** You must be able to safely lift 45 lbs. (20 kg) to raise, lower, or move the treadmill.

1. Hold the metal frame firmly in the location shown by the arrow at the right. **CAUTION:** To decrease the possibility of injury, do not lift the frame by the plastic foot rails. Make sure you bend your legs and keep your back straight. As you raise the frame, make sure to lift with your legs rather than your back. Raise the frame about halfway to the vertical position.

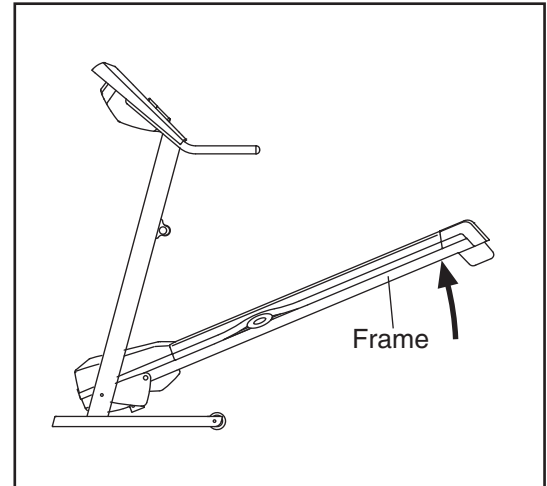

2. Move your right hand to the position shown and hold the treadmill firmly. Using your left hand, pull the latch knob to the left and hold it. Raise the frame until the hole in the isolator is aligned with the latch pin, and then slowly release the latch knob. **Make sure that the latch pin is fully inserted into the center of the isolator.**

To protect the floor or carpet from damage, place a mat under the treadmill. Keep the treadmill out of direct sunlight. Do not leave the treadmill in the storage position in temperatures above 85° F (30° C).

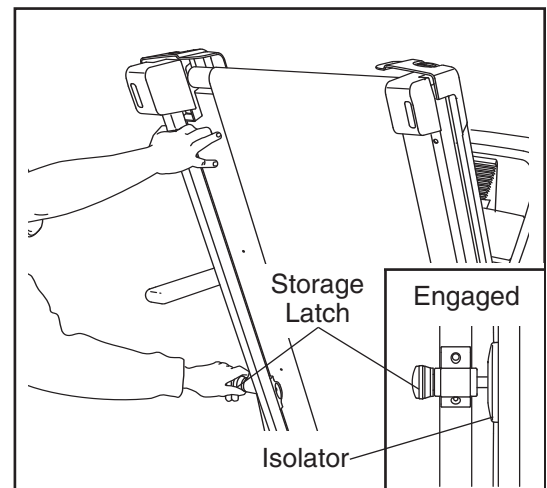

## HOW TO MOVE THE TREADMILL

Before moving the treadmill, convert it to the storage position as described above. **Make sure that the latch pin is fully inserted into the isolator.**

1. Hold one of the handrails and place your other hand on the deck. Place one foot against one of the wheels.
2. Tilt the treadmill back until it rolls freely on the wheels. Carefully move the treadmill to the desired location. **To reduce the risk of injury, use extreme caution while moving the treadmill. Do not move the treadmill over an uneven surface.**
3. Place one foot against one of the wheels, and carefully lower the treadmill until it is resting in the storage position.

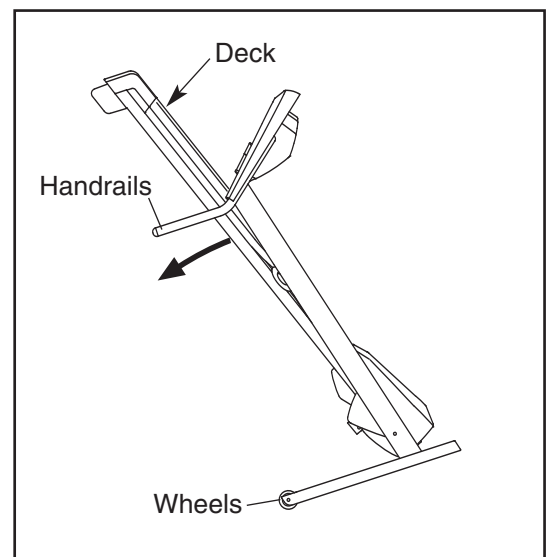

## HOW TO LOWER THE TREADMILL FOR USE

1. Hold the treadmill with your right hand as shown. Pull the latch knob to the left and hold it. Pivot the frame down until it is past the latch pin. Release the latch knob.

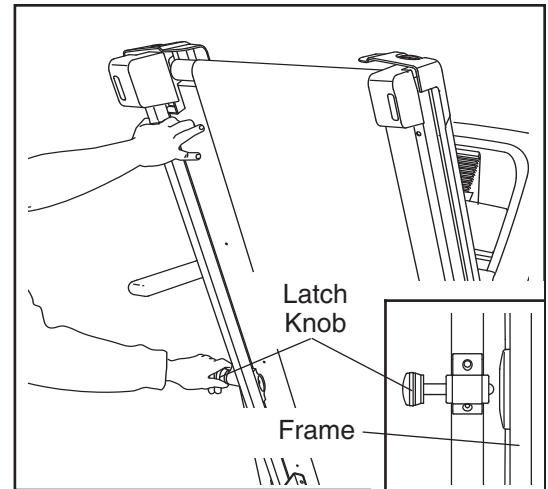

2. **Hold the metal frame firmly with both hands**, and lower it to the floor. **CAUTION: To decrease the possibility of injury, do not lower the frame by gripping only the plastic foot rails; do not drop the frame to the floor. Make sure to bend your legs and keep your back straight.**

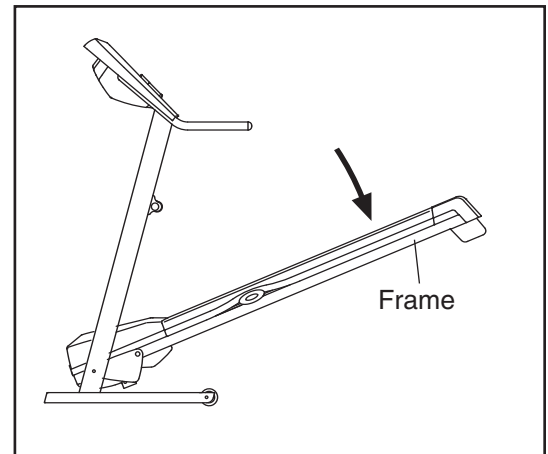

# TROUBLESHOOTING

Most treadmill problems can be solved by following the steps below. Find the symptom that applies, and follow the steps listed. If further assistance is needed, please see the front cover of this manual.

**PROBLEM: The power does not turn on**

**SOLUTION:** a. Make sure that the power cord is plugged into a surge suppressor, and that the surge suppressor is plugged into a properly grounded outlet (see page 11). Use only a single-outlet surge suppressor that meets all of the specifications described on page 11. Important: The treadmill is not compatible with GFCI-equipped outlets.

b. After the power cord has been plugged in, make sure that the key is inserted into the console.

c. Check the reset/off circuit breaker located on the treadmill frame near the power cord. If the switch protrudes as shown, the circuit breaker has tripped. To reset the circuit breaker, wait for five minutes and then press the switch back in.

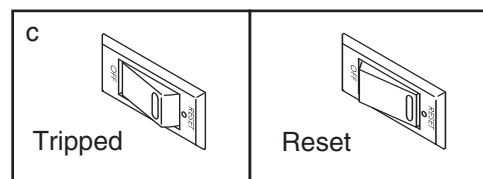

**PROBLEM: The power turns off during use**

**SOLUTION:** a. Check the reset/off circuit breaker located on the treadmill frame near the power cord (see the drawing above). If the circuit breaker has tripped, wait for five minutes and then press the switch back in.

b. Make sure that the power cord is plugged in. If the power cord is plugged in, unplug it, wait for five minutes, and then plug it back in.

c. Remove the key from the console. Reinsert the key into the console.

d. If the treadmill still will not run, see the front cover of this manual.

**PROBLEM: The displays of the console do not function properly**

**SOLUTION:** a. Remove the key from the console and **UNPLUG THE POWER CORD**. Remove the two Foot Rail Screws (4) and the two Hood Screws (86) and carefully remove the Hood (1).

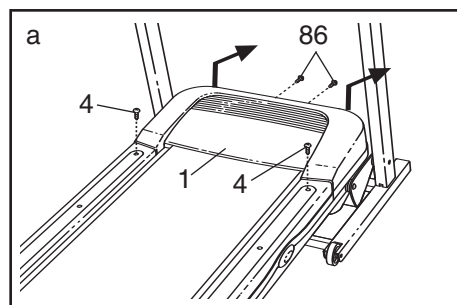

Locate the Reed Switch (62) and the Magnet (67) on the left side of the Pulley (64). Turn the Pulley until the Magnet is aligned with the Reed Switch. **Make sure that the gap between the Magnet and the Reed Switch is about 1/8 in. (3 mm).** If necessary, loosen the 3/4" Tek Screw (38), move the Reed Switch slightly, and then retighten the Screw. Reattach the Hood (not shown), and run the treadmill for a few minutes to check for a correct speed reading.

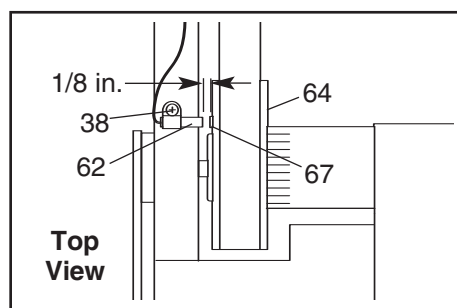

**PROBLEM: The console displays remain lit when you remove the key from the console**

**SOLUTION:** a. The console features a display demo mode, designed to be used if the treadmill is displayed in a store. If the displays remain lit when you remove the key, the demo mode is turned on. To turn off the demo mode, hold down the Stop button for a few seconds. If the displays are still lit, see THE INFORMATION MODE on page 17 to turn off the demo mode.

**PROBLEM: The walking belt slows when walked on**

**SOLUTION:** a. Use only a single-outlet surge suppressor that meets all of the specifications described on page 11.

b. If the walking belt is overtightened, treadmill performance may decrease and the walking belt may become damaged. Remove the key and **UNPLUG THE POWER CORD**. Using the hex key, turn both rear roller bolts counterclockwise, 1/4 of a turn. When the walking belt is properly tightened, you should be able to lift each edge of the walking belt 2 to 3 in. (5 to 7 cm) off the walking platform. Be careful to keep the walking belt centered. Then, plug in the power cord, insert the key, and run the treadmill for a few minutes. Repeat until the walking belt is properly tightened.

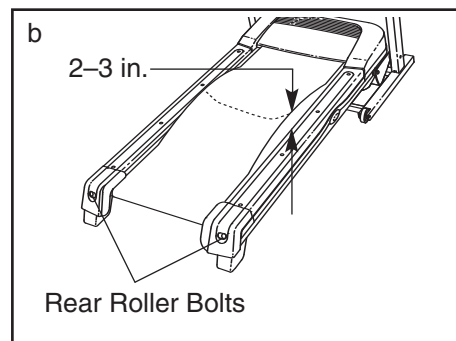

c. If the walking belt still slows when walked on, please see the front cover of this manual.

**PROBLEM: The walking belt is off-center or slips when walked on**

**SOLUTION:** a. If the walking belt is off-center, first remove the key and **UNPLUG THE POWER CORD**. **If the walking belt has shifted to the left**, use the hex key to turn the left rear roller bolt clockwise 1/2 of a turn; **if the walking belt has shifted to the right**, turn the left bolt counterclockwise 1/2 of a turn. Be careful not to overtighten the walking belt. Then, plug in the power cord, insert the key, and run the treadmill for a few minutes. Repeat until the walking belt is centered.

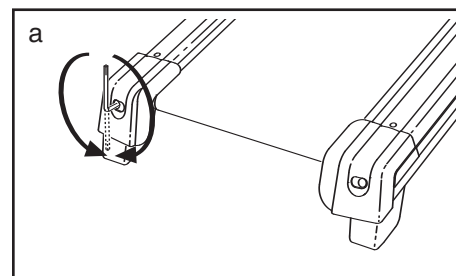

b. If the walking belt slips when walked on, first remove the key and **UNPLUG THE POWER CORD**. Using the hex key, turn both rear roller bolts clockwise, 1/4 of a turn. When the walking belt is correctly tightened, you should be able to lift each edge of the walking belt 2 to 3 in. (5 to 7 cm) off the walking platform. Be careful to keep the walking belt centered. Then, plug in the power cord, insert the key, and carefully walk on the treadmill for a few minutes. Repeat until the walking belt is properly tightened.

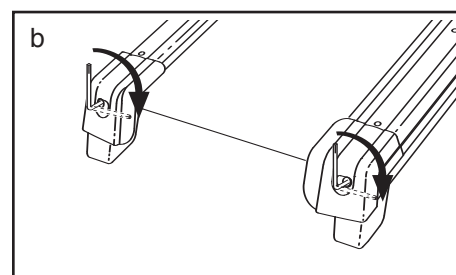

# EXERCISE GUIDELINES

**⚠️ WARNING:** Before beginning this or any exercise program, consult your physician. This is especially important for persons over the age of 35 or persons with pre-existing health problems.

The pulse sensor is not a medical device. Various factors may affect the accuracy of heart rate readings. The pulse sensor is intended only as an exercise aid in determining heart rate trends in general.

These guidelines will help you to plan your exercise program. For detailed exercise information, obtain a reputable book or consult your physician. Remember, proper nutrition and adequate rest are essential for successful results.

## EXERCISE INTENSITY

Whether your goal is to burn fat or to strengthen your cardiovascular system, exercising at the proper intensity is the key to achieving results. You can use your heart rate as a guide to find the proper intensity level. The chart below shows recommended heart rates for fat burning and aerobic exercise.

165	155	145	140	130	125	115	♥️
145	138	130	125	118	110	103	♥️
125	120	115	110	105	95	90	♥️
<hr/>							
20	30	40	50	60	70	80	

To find the proper intensity level, find your age at the bottom of the chart (ages are rounded off to the nearest ten years). The three numbers listed above your age define your “training zone.” The lowest number is the heart rate for fat burning, the middle number is the heart rate for maximum fat burning, and the highest number is the heart rate for aerobic exercise.

**Burning Fat**—To burn fat effectively, you must exercise at a low intensity level for a sustained period of time. During the first few minutes of exercise, your body uses *carbohydrate calories* for energy. Only after the first few minutes of exercise does your body begin to use stored *fat calories* for energy. If your goal is to burn fat, adjust the intensity of your exercise until your heart rate is near the lowest number in your training zone. For maximum fat burning, exercise with your heart rate near the middle number in your training zone.

**Aerobic Exercise**—If your goal is to strengthen your cardiovascular system, you must perform aerobic exercise, which is activity that requires large amounts of oxygen for prolonged periods of time. For aerobic exercise, adjust the intensity of your exercise until your heart rate is near the highest number in your training zone.

## WORKOUT GUIDELINES

**Warming up**—Start with 5 to 10 minutes of stretching and light exercise. A warm-up increases your body temperature, heart rate, and circulation in preparation for exercise.

**Training Zone Exercise**—Exercise for 20 to 30 minutes with your heart rate in your training zone. (During the first few weeks of your exercise program, do not keep your heart rate in your training zone for longer than 20 minutes.) Breathe regularly and deeply as you exercise—never hold your breath.

**Cooling down**—Finish with 5 to 10 minutes of stretching. Stretching increases the flexibility of your muscles and helps to prevent post-exercise problems.

## EXERCISE FREQUENCY

To maintain or improve your condition, complete three workouts each week, with at least one day of rest between workouts. After a few months of regular exercise, you may complete up to five workouts each week, if desired. Remember, the key to success is to make exercise a regular and enjoyable part of your everyday life.

# PART LIST—Model No. HCTL39607.0

R0707A

Key No.	Qty.	Description	Key No.	Qty.	Description
1	1	Hood	52	2	Roller Bushing
2	24	3/4" Screw	53	2	Lift Frame Bolt
3	1	Left Foot Rail	54	4	3/8" Nut
4	8	Foot Rail Screw	55	1	Lift Motor
5	2	Motor Tension Bolt	56	1	Stop Bracket
6	4	U-nut	57	1	Incline Motor Bolt, Top
7	8	Wire Tie	58	1	Incline Motor Bolt, Bottom
8	2	Motor Bolt	59	1	Lift Frame
9	1	Drive Motor	60	2	Motor Tension Nut
10	1	Motor Bracket	61	1	Motor Belt
11	2	Rear Roller Star Washer	62	1	Reed Switch
12	2	Power Bracket Star Washer	63	1	Clip
13	1	Power Cord	64	1	Front Roller/Pulley
14	1	Reset/Off Circuit Breaker	65	1	Motor Pivot Bolt
15	2	Foot Rail Decal	66	2	Platform Bolt, Front
16	1	Console Fan	67	1	Magnet
17	4	Handrail Endcap	68	2	Belt Guide
18	2	Handrail	69	4	Isolator Screw
19	4	Handrail Star Washer	70	2	Isolator
20	4	Handrail Bolt	71	4	Belt Guide Screw
21	2	1/4" Star Washer	72	1	Walking Belt
22	2	Console Bolt	73	1	Walking Platform
23	1	Key/Clip	74	1	Frame
24	2	Frame Pivot Spacer	75	1	Right Foot Rail
25	1	Console	76	4	Platform Nut
26	1	Console Base	77	8	Rear Roller Washer/Isolator Washer
27	9	Sliver Ground Screw	78	2	Platform Bolt, Rear
28	1	Upright Wire	79	1	Rear Roller
29	1	Latch Pin Assembly	80	1	Right Rear Foot
30	1	Latch Housing	81	2	Rear Roller Bracket
31	1	Left Upright	82	2	Rear Roller Bolt
32	2	Frame Bolt	83	1	Left Rear Foot
33	4	Frame Washer	84	1	Rear Roller Ground Wire
34	2	Frame Spacer	85	1	Hex Key
35	2	Base Endcap	86	2	Hood Screw
36	1	Right Upright	87	1	5/32" Hex Key
37	4	Base Pad	88	1	Power Cord Grommet
38	13	3/4" Tek Screw	89	1	Power Cord
39	5	Upright Star Washer/Motor Washer	90	1	Filter Wire
40	4	Upright Bolt	91	1	14" Blue Wire, 2F
41	2	Caution Decal	92	1	8" Wire Tie
42	1	Console Support Bracket	93	1	23" Wire Tie
43	1	English Warning Decal	94	1	French Warning Decal
44	4	Wheel Spacer	95	2	Wheel Bolt
45	2	Wheel	*	—	4" Red Wire, M/F
46	3	Plastic Tie	*	—	4" Black Wire, M/F
47	5	Nut	*	—	8" Green Wire, F/R
48	1	Base	*	—	4" Blue Wire, 2F
49	1	Releasable Tie	*	—	User's Manual
50	1	Belly Pan			
51	1	Controller			

\*These parts are not illustrated.  
Specifications are subject to change without notice.



# EXPLODED DRAWING A—Model No. HCTL39607.0

R0707A

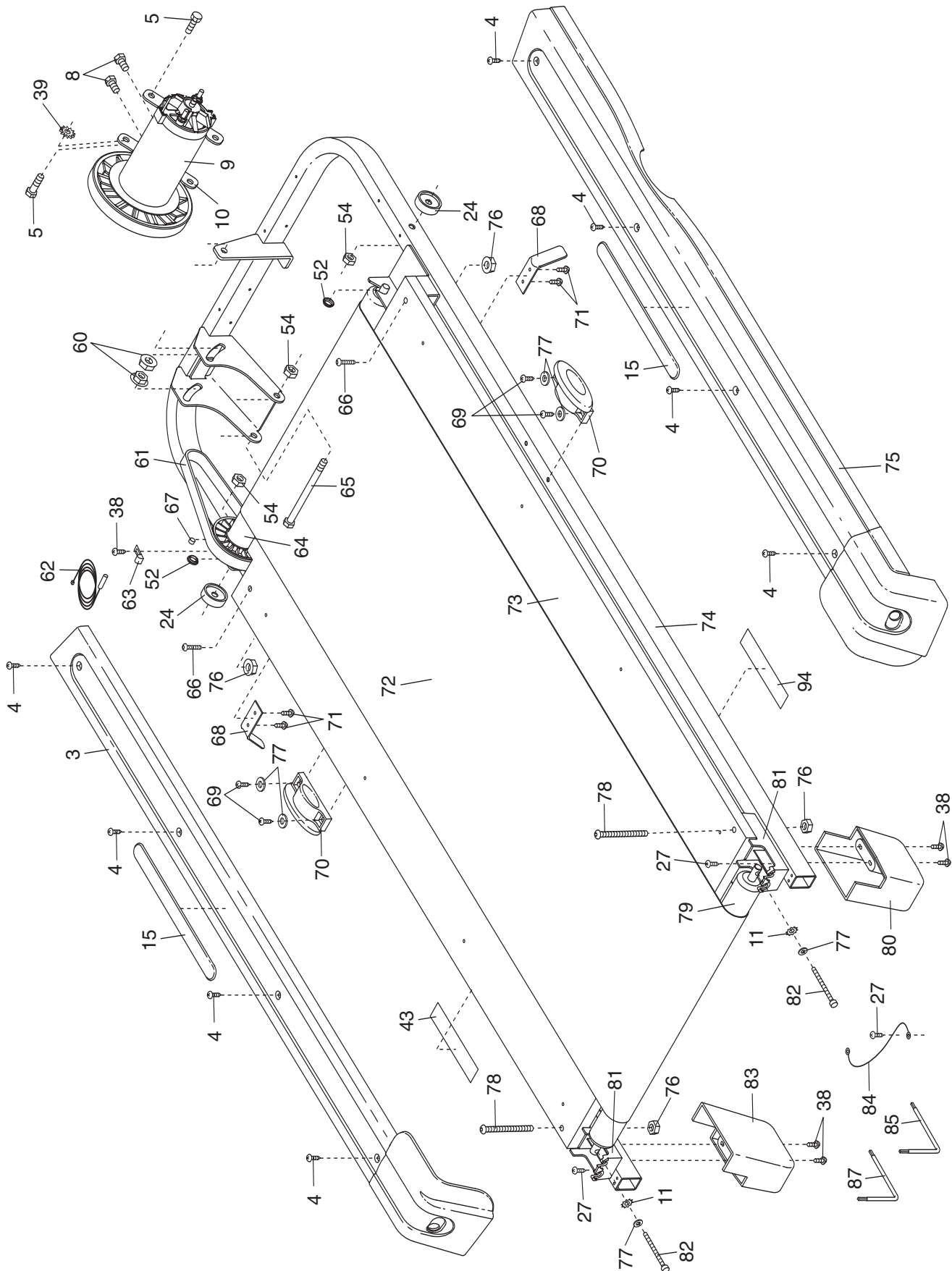



# EXPLODED DRAWING B—Model No. HCTL39607.0

R0707A

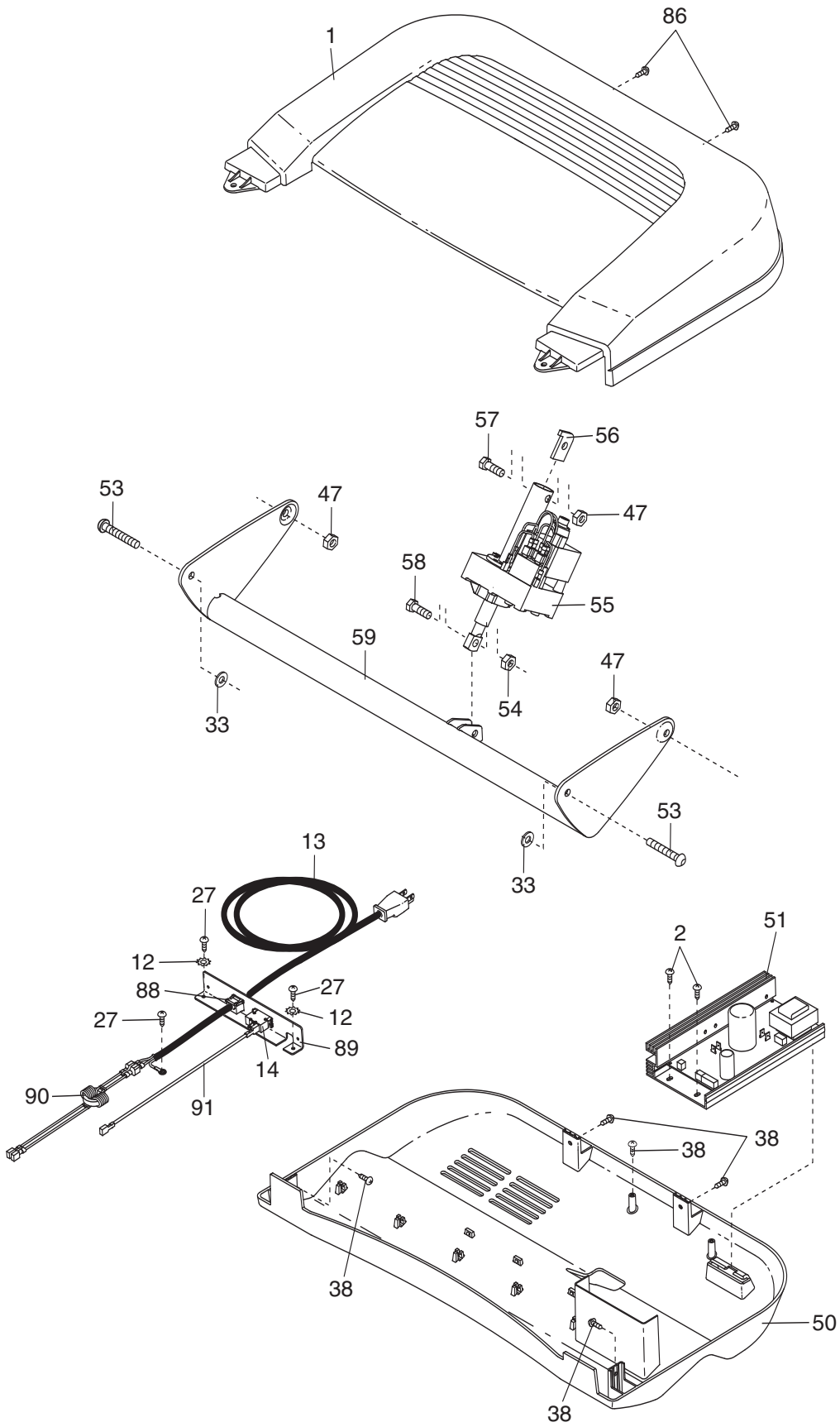

# EXPLODED DRAWING C—Model No. HCTL39607.0

R0707A

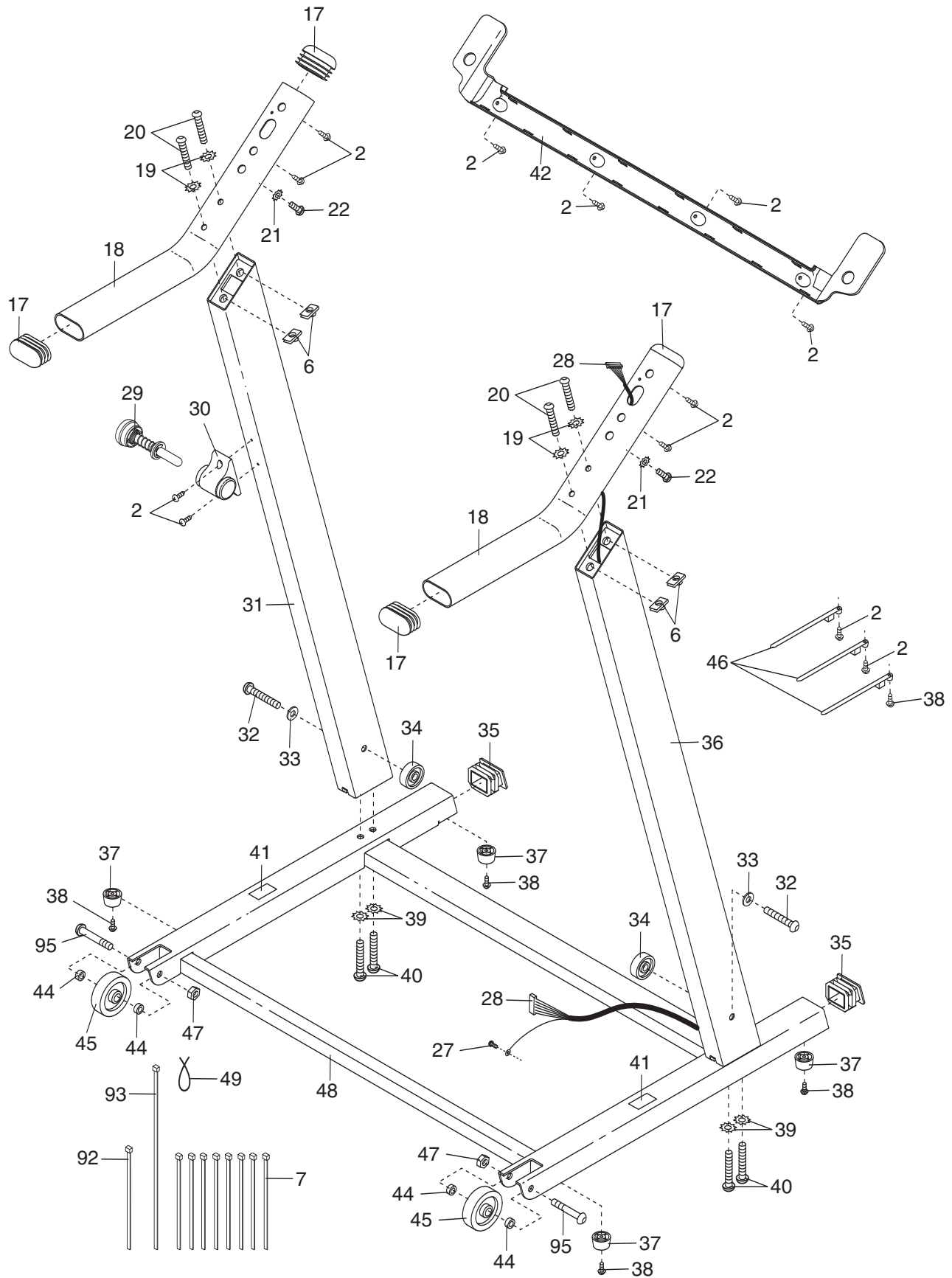

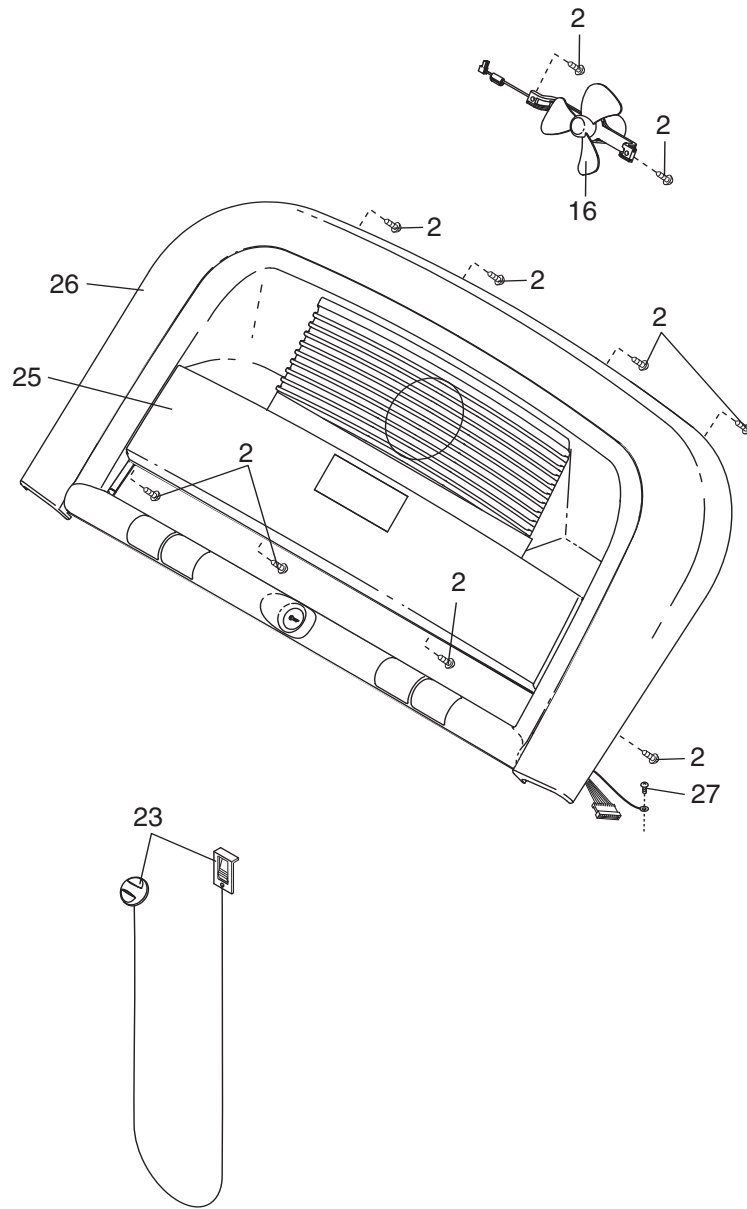

---

# ORDERING REPLACEMENT PARTS

To order replacement parts, please see the front cover of this manual. To help us assist you, be prepared to provide the following information when contacting us:

- the model number and serial number of the product (see the front cover of this manual)
- the name of the product (see the front cover of this manual)
- the key number and description of the replacement parts(s) (see the PART LIST and the EXPLODED DRAWING near the end of this manual)

## LIMITED WARRANTY

ICON OF CANADA, INC. (ICON) warrants this product to be free from defects in workmanship and material, under normal use and service conditions. The frame is warranted for ten (10) years after the date of purchase. The drive motor is warranted for three (3) year after the date of purchase. Parts are warranted for one (1) year after the date of purchase. Labor is warranted for ninety (90) days after the date of purchase.

This warranty extends only to the original purchaser. ICON's obligation under this warranty is limited to replacing or repairing, at ICON's option, the product through one of its authorized service centers. All repairs for which warranty claims are made must be pre-authorized by ICON. This warranty does not extend to any product or damage to a product caused by or attributable to freight damage, abuse, misuse, improper or abnormal usage or repairs not provided by an ICON authorized service center, to products used for commercial or rental purposes, or to products used as store display models. No other warranty beyond that specifically set forth above is authorized by ICON.

ICON is not responsible or liable for indirect, special or consequential damages arising out of or in connection with the use or performance of the product or damages with respect to any economic loss, loss of property, loss of revenues or profits, loss of enjoyment or use, costs of removal, installation or other consequential damages of whatsoever nature. Some provinces do not allow the exclusion or limitation of incidental or consequential damages. Accordingly, the above limitation may not apply to you. The warranty extended hereunder is in lieu of any and all other warranties and any implied warranties of merchantability or fitness for a particular purpose is limited in its scope and duration to the terms set forth herein. Some provinces do not allow limitations on how long an implied warranty lasts. Accordingly, the above limitation may not apply to you.

This warranty gives you specific legal rights. You may also have other rights which vary from province to province or so specified by the retailer of your equipment.

**ICON OF CANADA, INC., 900 de l'Industrie, St. Jerôme, QC J7Y 4B8**