

HEALTHRIDER® H35xr

www.healthrider.com

Model No. HREX53409.2

Serial No. _____

Write the serial number in the space above for reference.

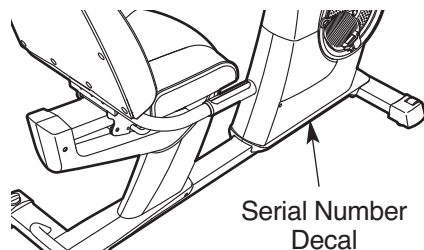

USER'S MANUAL

QUESTIONS?

If you have questions, or if parts are damaged or missing, **DO NOT CONTACT THE STORE**; please contact Customer Care.

IMPORTANT: Please register this product (see the limited warranty on the back cover of this manual) before contacting Customer Care.

CALL TOLL-FREE:

1-888-922-4222

Mon.–Fri., 6 a.m.–6 p.m. MT

Sat. 8 a.m.–4 p.m. MT

ON THE WEB:

www.healthriderservice.com

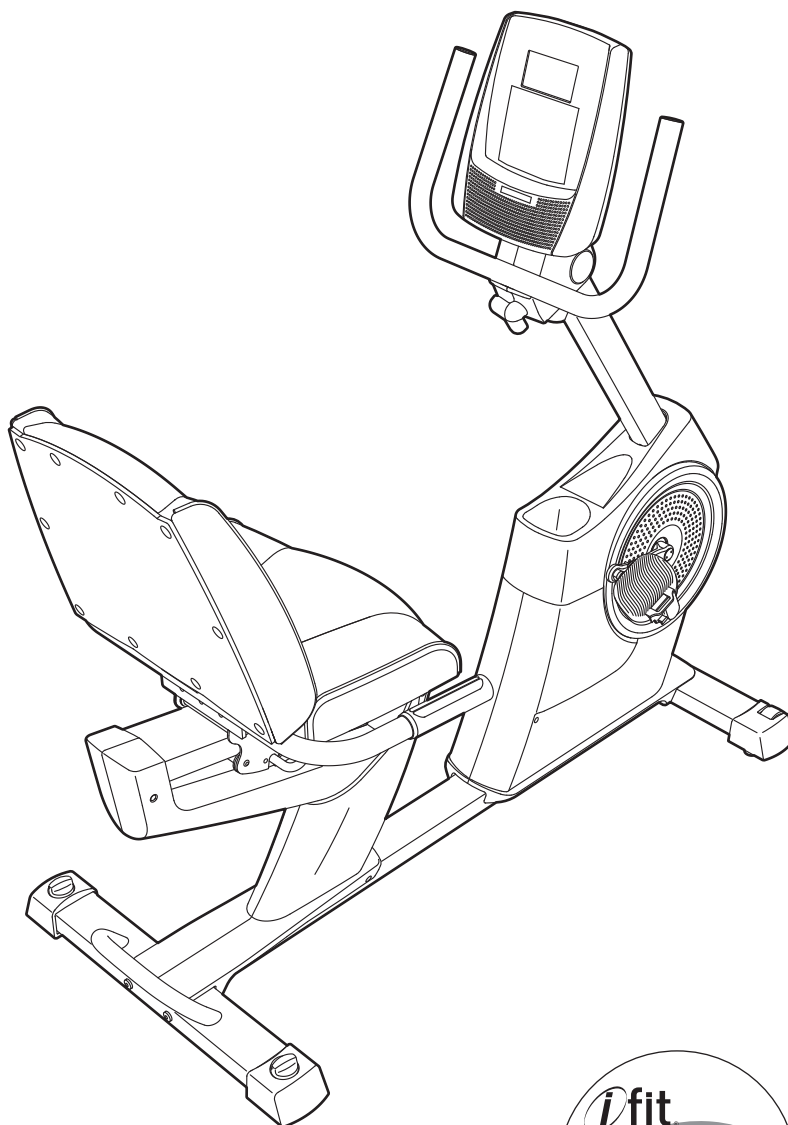

CAUTION

Read all precautions and instructions in this manual before using this equipment. Keep this manual for future reference.

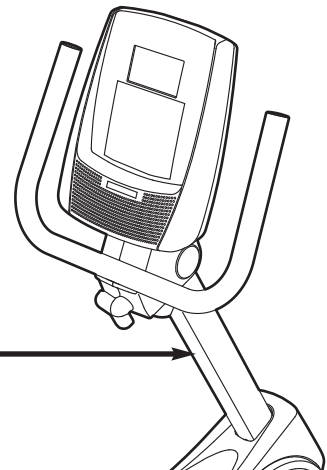
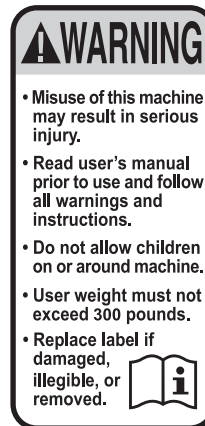

TABLE OF CONTENTS

WARNING DECAL PLACEMENT2
IMPORTANT PRECAUTIONS3
BEFORE YOU BEGIN4
ASSEMBLY5
HOW TO USE THE EXERCISE BIKE13
MAINTENANCE AND TROUBLESHOOTING21
EXERCISE GUIDELINES22
PART LIST24
EXPLODED DRAWING26
ORDERING REPLACEMENT PARTSBack Cover
LIMITED WARRANTYBack Cover

WARNING DECAL PLACEMENT

This drawing shows the location(s) of the warning decal(s). **If a decal is missing or illegible, see the front cover of this manual and request a free replacement decal. Apply the decal in the location shown.** Note: The decal(s) may not be shown at actual size.



IMPORTANT PRECAUTIONS

⚠ WARNING: To reduce the risk of serious injury, read all important precautions and instructions in this manual and all warnings on your exercise bike before using your exercise bike. ICON assumes no responsibility for personal injury or property damage sustained by or through the use of this product.

1. Before beginning any exercise program, consult your physician. This is especially important for persons over age 35 or persons with pre-existing health problems.
2. Use the exercise bike only as described in this manual.
3. It is the responsibility of the owner to ensure that all users of the exercise bike are adequately informed of all precautions.
4. The exercise bike is intended for home use only. Do not use the exercise bike in a commercial, rental, or institutional setting.
5. Keep the exercise bike indoors, away from moisture and dust. Do not put the exercise bike in a garage or covered patio, or near water.
6. Place the exercise bike on a level surface with at least 2 ft. (0.6 m) of clearance around the exercise bike. To protect the floor or carpet from damage, place a mat under the exercise bike.
7. Inspect and properly tighten all parts regularly. Replace any worn parts immediately.
8. Keep children under age 12 and pets away from the exercise bike at all times.
9. Wear appropriate clothes while exercising; do not wear loose clothes that could become caught on the exercise bike. Always wear athletic shoes for foot protection.
10. The exercise bike should not be used by persons weighing more than 300 lbs. (136 kg).
11. The pulse sensor is not a medical device. Various factors, including the user's movement, may affect the accuracy of heart rate readings. The pulse sensor is intended only as an exercise aid in determining heart rate trends in general.
12. Always keep your back straight while using the exercise bike; do not arch your back.
13. Over exercising may result in serious injury or death. If you feel faint or if you experience pain while exercising, stop immediately and cool down.

BEFORE YOU BEGIN

Thank you for selecting the revolutionary HEALTHRIDER® H35XR exercise bike. Cycling is an effective exercise for increasing cardiovascular fitness, building endurance, and toning the body. The H35XR exercise bike provides an impressive selection of features designed to make your workouts at home more effective and enjoyable.

For your benefit, read this manual carefully before you use the exercise bike. If you have questions

after reading this manual, please see the front cover of this manual. To help us assist you, note the product model number and serial number before contacting us. The model number and the location of the serial number decal are shown on the front cover of this manual.

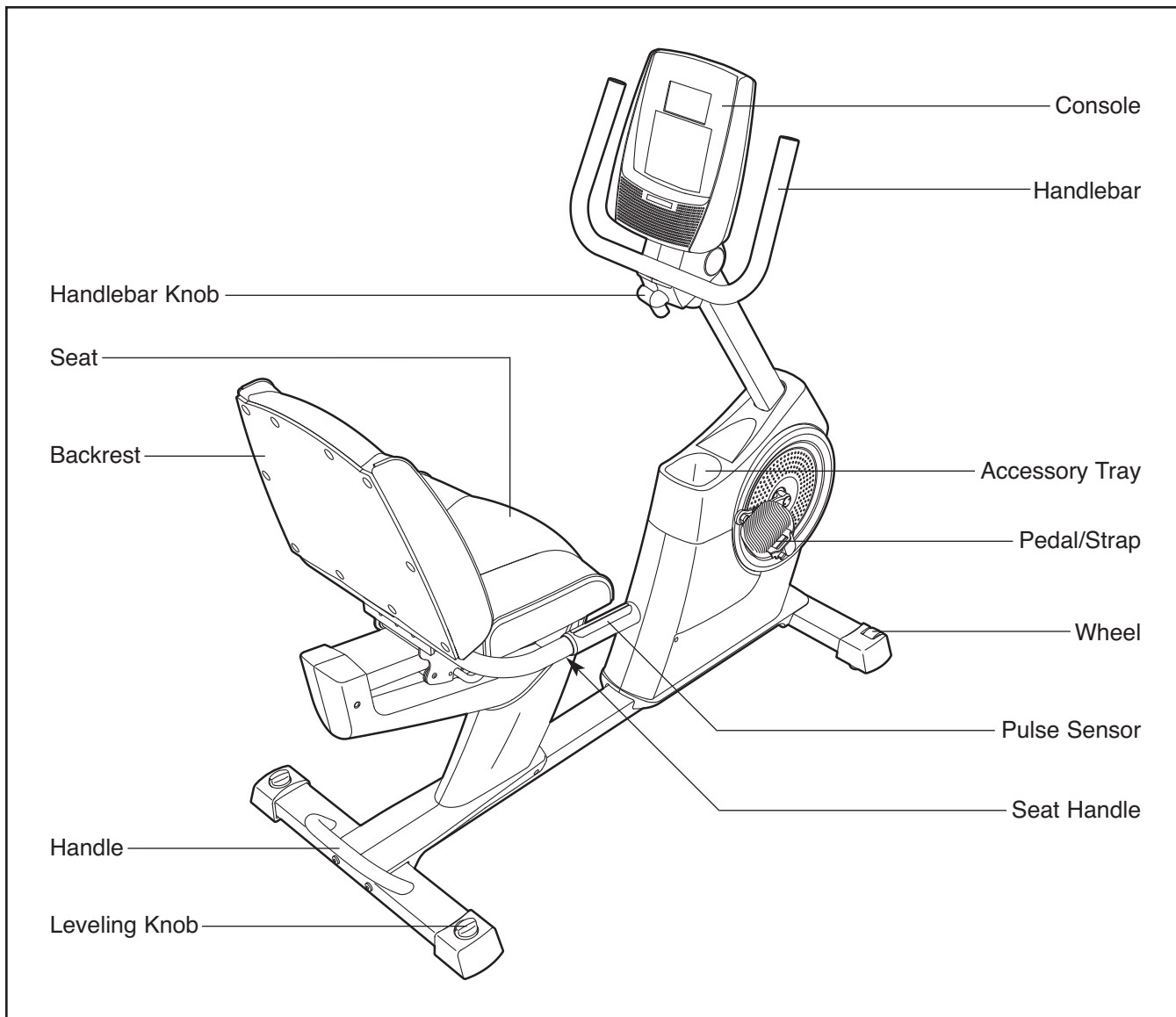

Before reading further, please familiarize yourself with the parts that are labeled in the drawing below.



ASSEMBLY

To hire an authorized service technician to assemble the exercise bike, call 1-800-445-2480.

Assembly requires two persons. Place all parts of the exercise bike in a cleared area and remove the packing materials. Do not dispose of the packing materials until assembly is completed.

In addition to the included tool(s), assembly requires a Phillips screwdriver  and an adjustable wrench .

See the drawings below to identify the small parts needed for assembly. The number in parentheses below each drawing is the key number of the part, from the PART LIST near the end of this manual. The number following the key number is the quantity needed for assembly. **Note: If a part is not in the hardware kit, check to see if it has been preassembled. To avoid damaging parts, do not use power tools for assembly.**

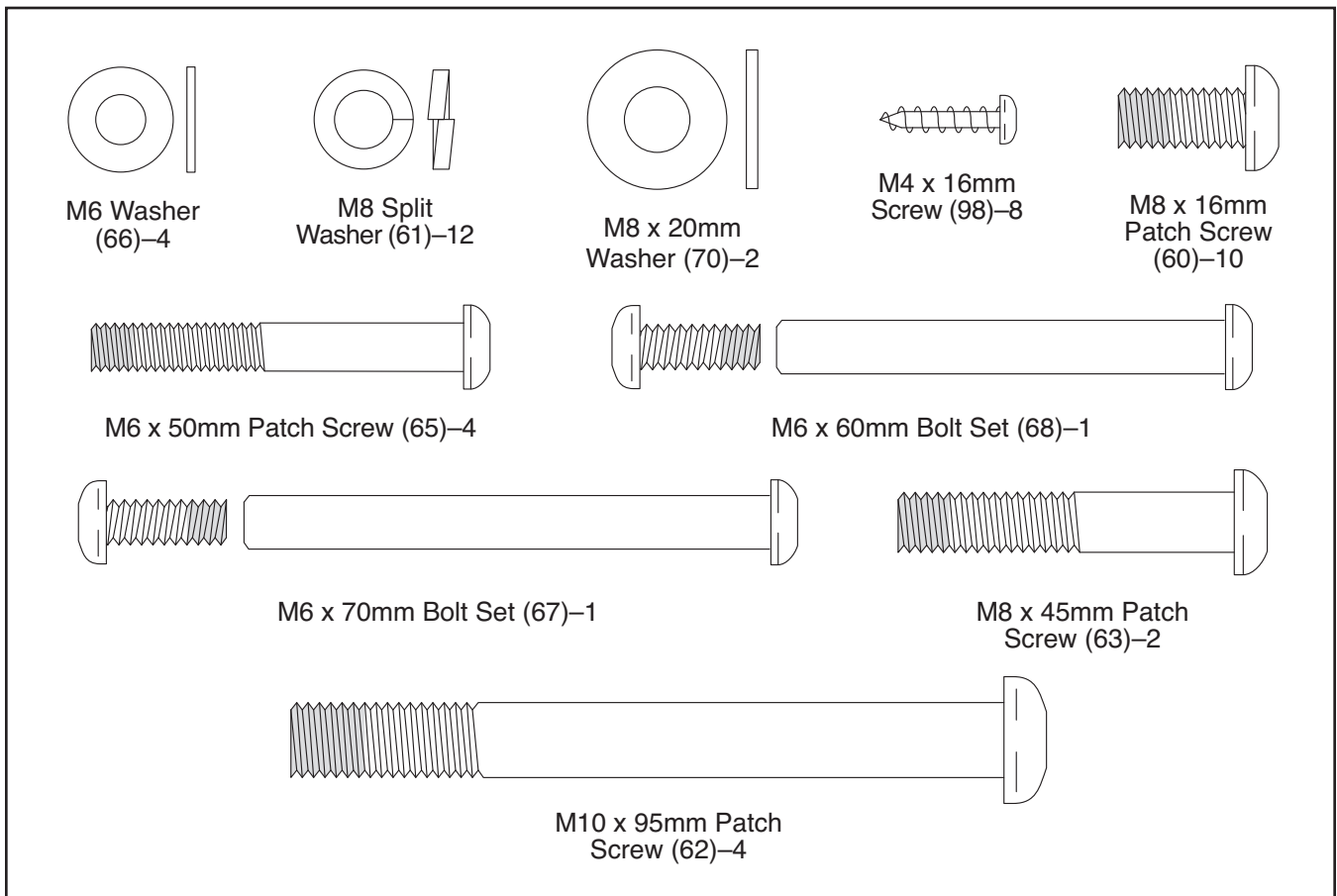

1.

To make assembly easier, read the information on page 5 before you begin.

While another person lifts the front of the Frame (1), attach the Front Stabilizer (2) to the Frame with two M10 x 95mm Patch Screws (62).

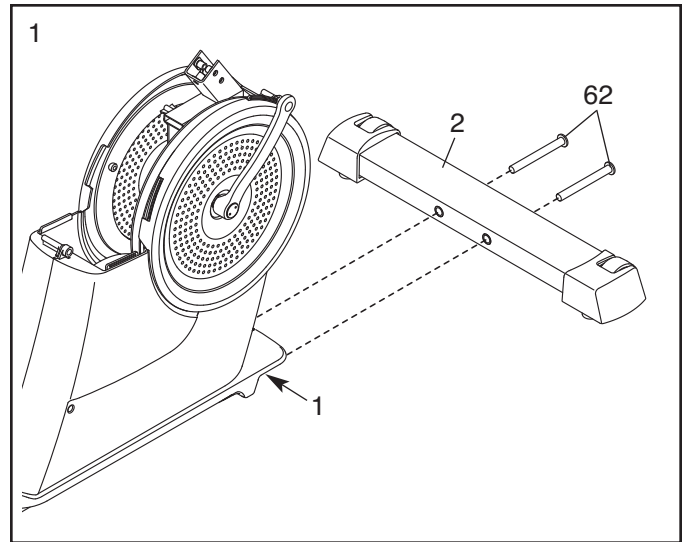

2. While another person lifts the rear of the Frame (1), attach the Rear Stabilizer (3) to the Frame with two M10 x 95mm Patch Screws (62).

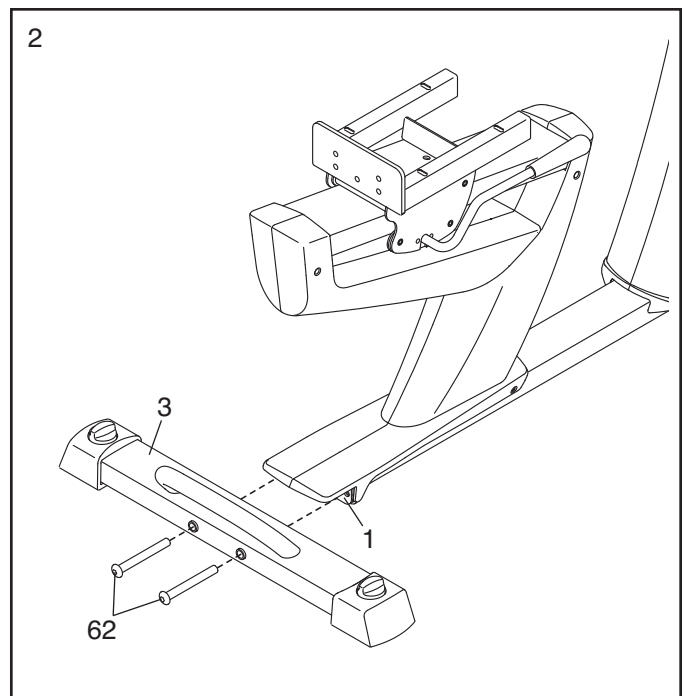

5. **Make sure that the Wire Harness (89) and the Frame Pulse Wire (91) are in the location shown.**

Using a small plastic bag to keep your fingers clean, apply a coat of the included grease to an M6 x 70mm Bolt Set (67).

Tip: Avoid pinching the wires. Attach the Handlebar (6) to the Upright (4) with the M6 x 70mm Bolt Set (67) and two M8 x 20mm Washers (70).

Then, attach an M6 x 60mm Bolt Set (68) through the bracket on the Handlebar (6). **Make sure that the Bolt Set is inside the bracket.**

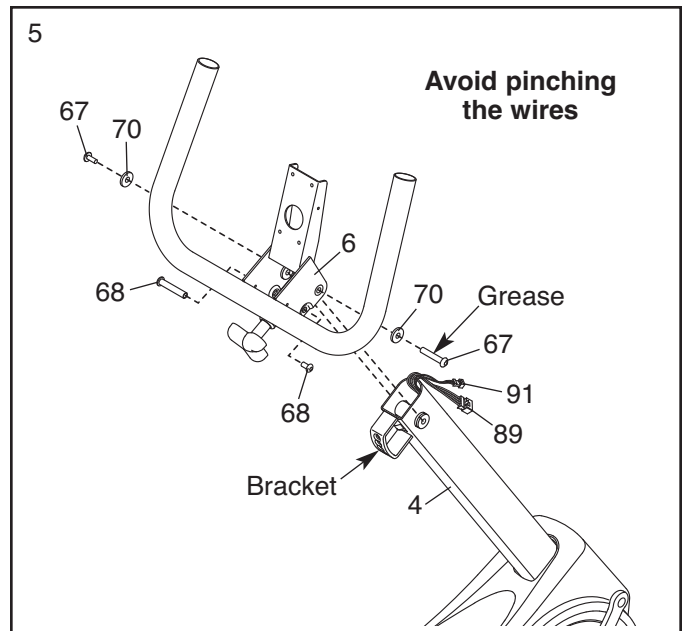

6. Insert the Wire Harness (89) and the Frame Pulse Wire (91) upward through the indicated hole in the Handlebar (6).

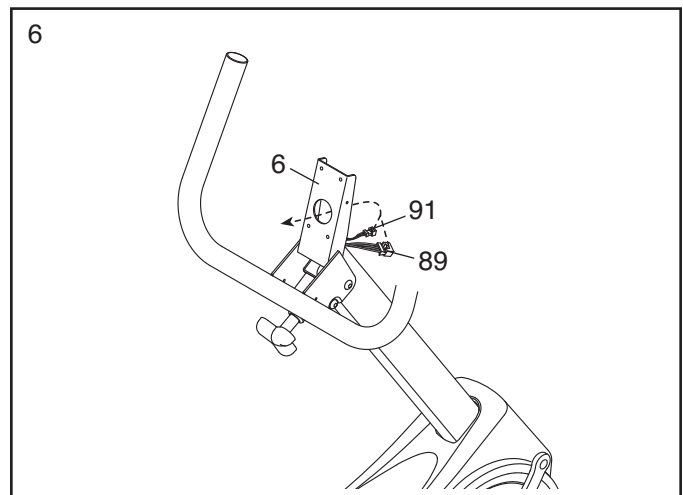

7. While another person holds the Console (7) near the Handlebar (6), connect the wires on the Console to the Wire Harness (89) and the Frame Pulse Wire (91).

Insert the excess wire downward into the Upright (4) or upward into the Console (7).

Tip: Avoid pinching the wires. Attach the Console (7) to the Handlebar (6) with four M4 x 16mm Screws (98).

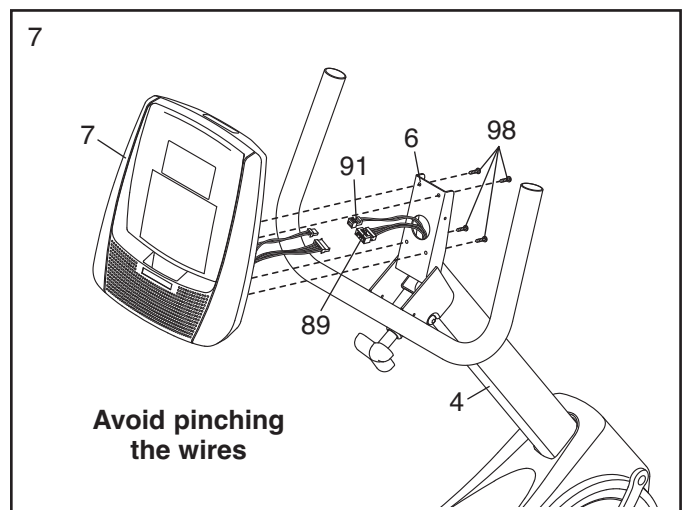

8. Identify the Right and Left Handlebar Covers (8, 9), which are marked with "Right" and "Left" stickers.

Attach the Right and Left Handlebar Covers (8, 9) around the Handlebar (6) and the Upright (4) with four M4 x 16mm Screws (98).

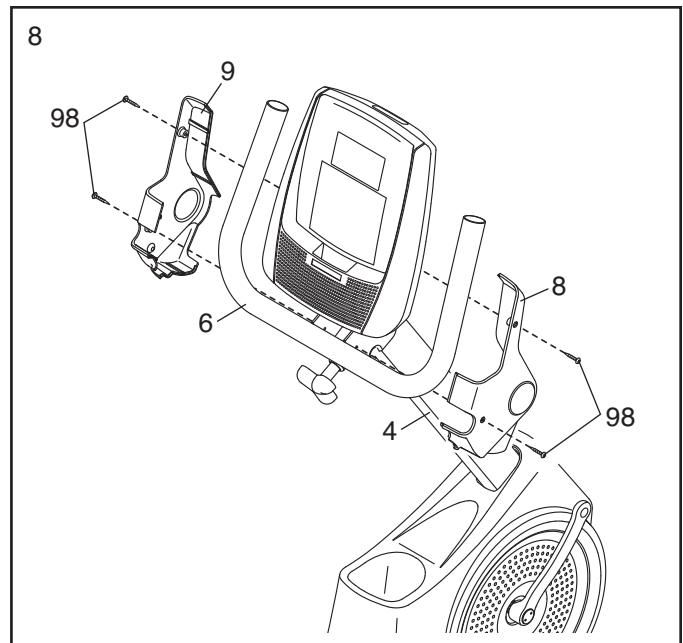

9. Attach the Seat (15) to the Seat Carriage (11) with four M6 x 50mm Patch Screws (65) and four M6 Washers (66) (only two of each are shown). **Note: The Patch Screws and Washers may be preattached to the underside of the Seat.**

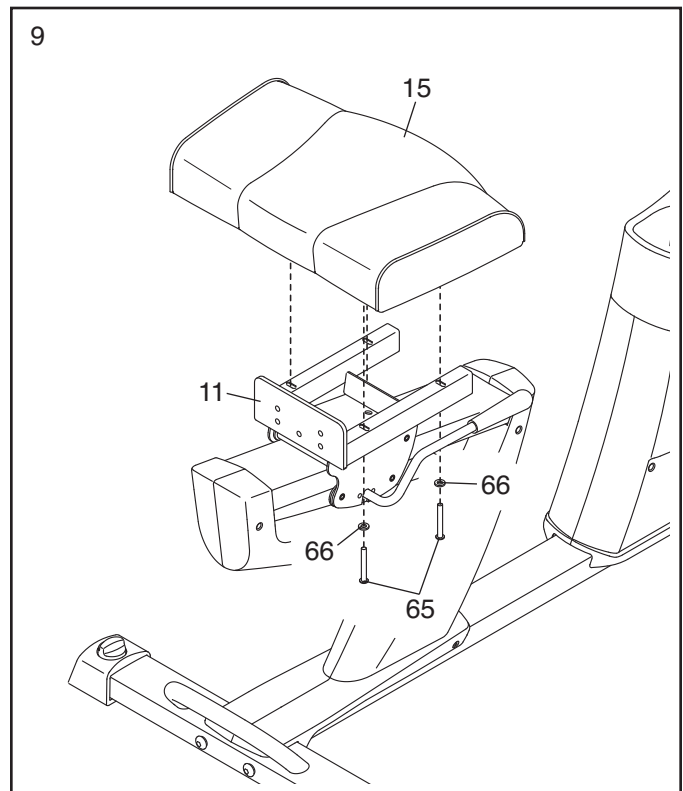

10. Attach the Backrest (13) to the Seat Carriage (11) with five M8 x 16mm Patch Screws (60) and five M8 Split Washers (61).

Tip: It may be helpful to adjust the seat during this step. See **HOW TO ADJUST THE SEAT** on page 13.

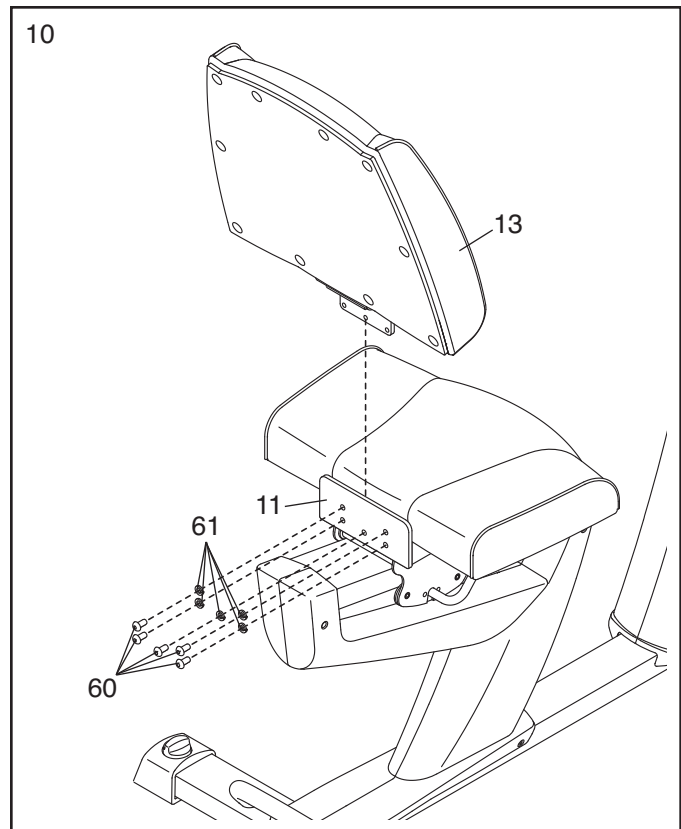

11. Identify and orient the Pulse Bar (12) so that the Pulse Grips (41) face upward.

Tip: Avoid pinching the Pulse Bar Pulse Wire (92). While a second person holds the Pulse Bar (12), attach the Pulse Bar to the Seat Carriage (11) with two M8 x 45mm Patch Screws (63) and two M8 Split Washers (61).

Tip: It may be helpful to adjust the seat during this step. See **HOW TO ADJUST THE SEAT** on page 13.

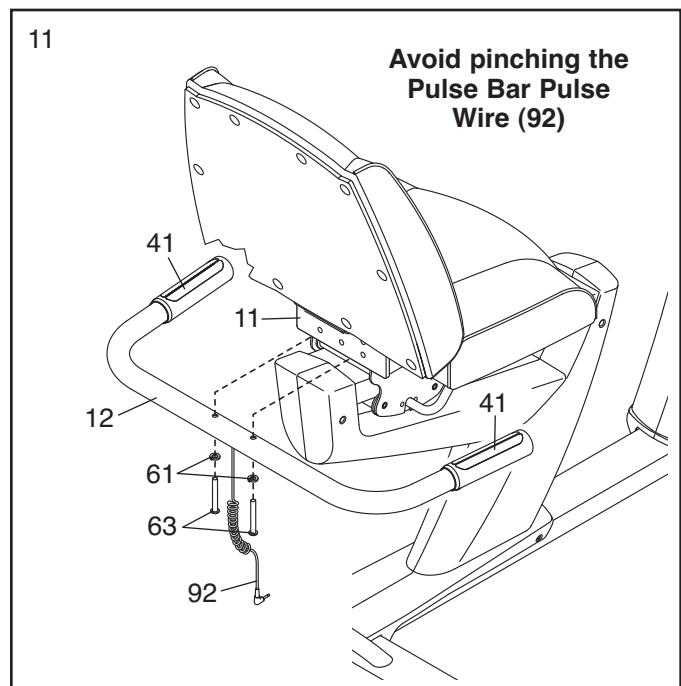

12. Plug the Pulse Bar Pulse Wire (92) into the Frame Pulse Receptacle (91) located in the Left Seat Shield (24).

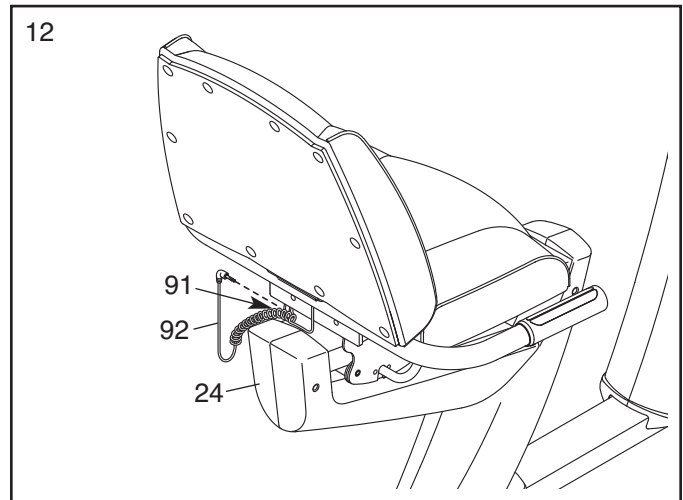

13. Identify the Right Pedal (16), which is marked with an "R."

Using an adjustable wrench, **firmly tighten** the Right Pedal (16) **clockwise** into the Right Crank Arm (17).

Firmly tighten the Left Pedal (not shown) **counterclockwise** into the Left Crank Arm (not shown).

Adjust the right strap to the desired position, and press the ends of the strap onto the tabs on the Right Pedal (16). **Adjust the strap on the Left Pedal (not shown) in the same way.**

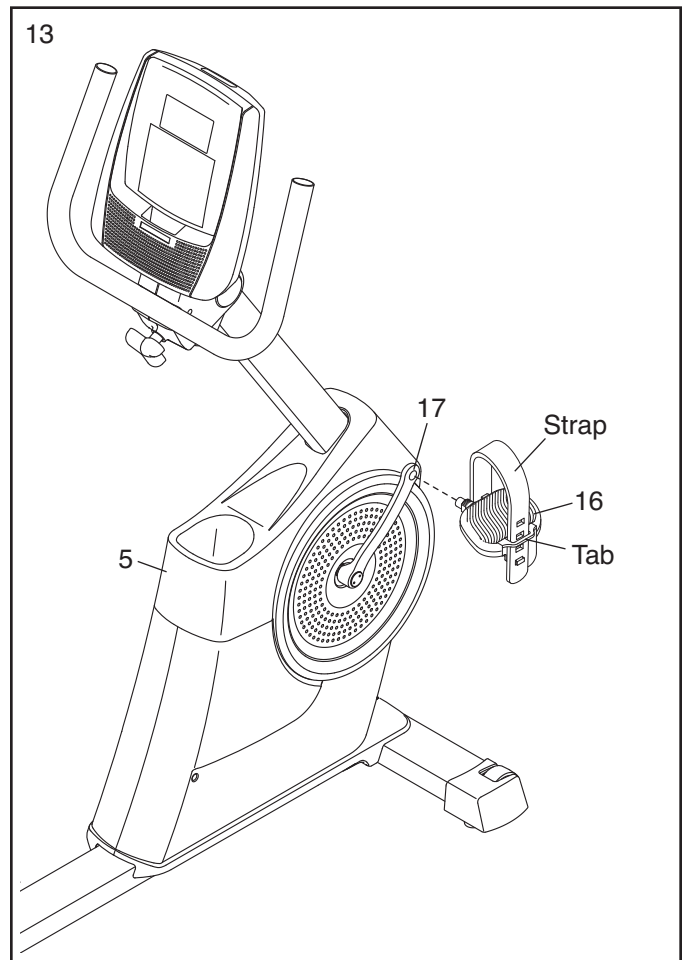

14. Plug the Power Adapter (104) into the receptacle on the frame of the exercise bike. To plug the Power Adapter into an outlet, see HOW TO PLUG IN THE POWER ADAPTER on page 13.

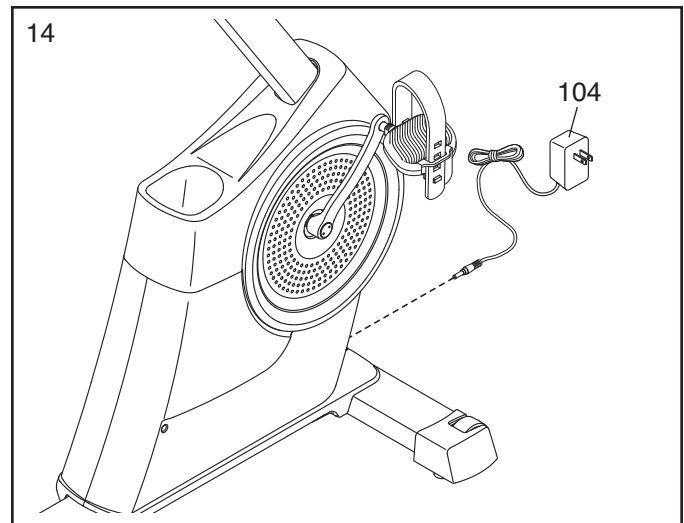

15. **Make sure that all parts are properly tightened before you use the exercise bike.** Note: After assembly is completed, some extra parts may be left over. Place a mat beneath the exercise bike to protect the floor.

HOW TO USE THE EXERCISE BIKE

HOW TO PLUG IN THE POWER ADAPTER

IMPORTANT: If the exercise bike has been exposed to cold temperatures, allow it to warm to room temperature before plugging in the power adapter. If you do not do this, you may damage the console displays or other electronic components.

Plug the power adapter into the receptacle on the frame of the exercise bike. Then, plug the power adapter into an appropriate outlet that is properly installed in accordance with all local codes and ordinances.

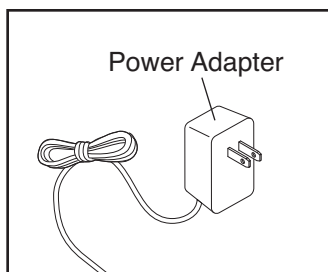

HOW TO ADJUST THE SEAT

The seat can be adjusted forward or backward to the position that is the most comfortable. To adjust the seat, push downward on the seat handle, slide the seat to the desired position, and then pull upward on the seat handle to lock the seat in place.

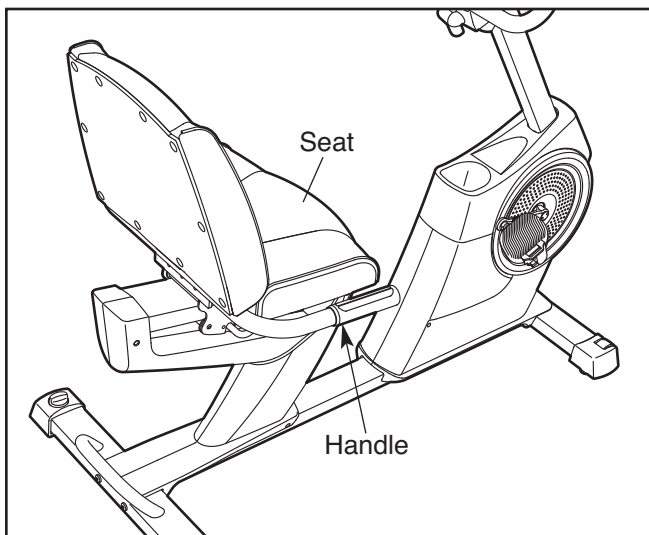

HOW TO ADJUST THE ANGLE OF THE HANDLEBAR

To adjust the angle of the handlebar, first loosen the knob a few turns. Next, pull the knob outward, pivot the handlebar to the desired angle, and then release the knob into an adjustment hole. **Make sure that the knob is engaged in one of the adjustment holes.** Then, tighten the knob.

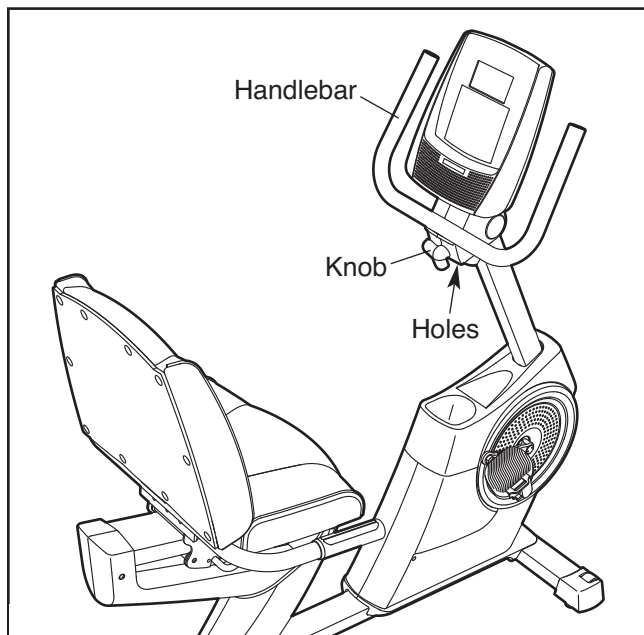

HOW TO ADJUST THE PEDAL STRAPS

To adjust the pedal straps, first pull the ends of the straps off the tabs on the pedals. Adjust the straps to the desired position, and then press the ends of the straps onto the tabs.

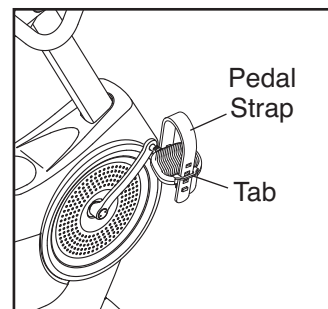

HOW TO MOVE THE EXERCISE BIKE

To move the exercise bike, hold the handle on the rear stabilizer and carefully lift it until the exercise bike can be moved on the front wheels. Carefully move the exercise bike to the desired location and then lower it.

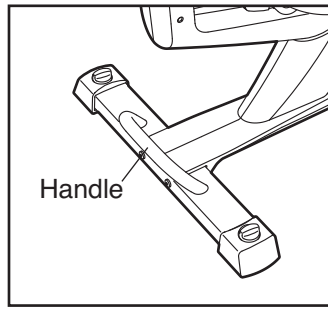

HOW TO LEVEL THE EXERCISE BIKE

If the exercise bike rocks slightly on your floor during use, turn one or both of the leveling knobs on the rear stabilizer and adjust the leveling feet until the rocking motion is eliminated.

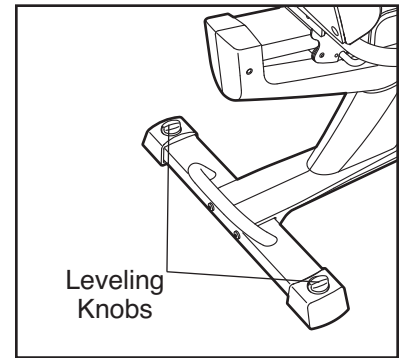

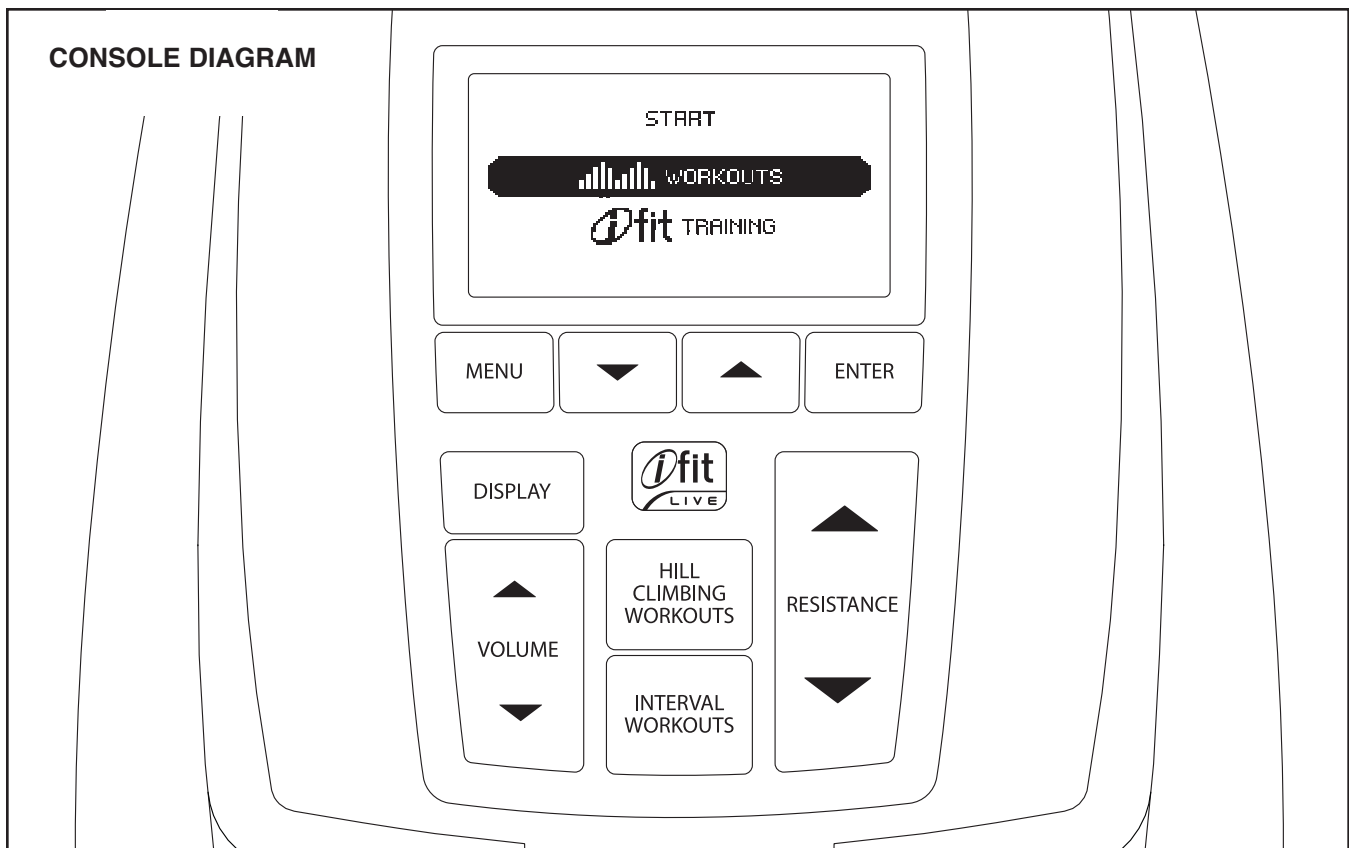

FEATURES OF THE CONSOLE

The advanced console offers an array of features designed to make your workouts more effective and enjoyable.

When you use the manual mode of the console, you can change the resistance of the pedals with the touch of a button. While you exercise, the console will display continuous exercise feedback. You can also measure your heart rate using the handgrip pulse sensor.

The console also offers twenty preset workouts—ten hill climbing workouts and ten interval workouts. Each workout automatically changes the resistance of the pedals and prompts you to vary your pedaling speed as it guides you through an effective workout.

The console also features an iFit training mode that allows your console to communicate with your wireless network through an optional iFit Live module.

With the iFit Live mode, you can download personalized workouts, create your own workouts, track your workout results, and access many other features. **See www.iFit.com for complete information.**

To purchase an iFit Live module at any time, go to www.iFit.com or call the telephone number on the front cover of this manual.

You can even connect your MP3 player or CD player to the console sound system and listen to your favorite music or audio books while you exercise.

To activate the console, see page 16. To turn off the console, see page 16. To use the manual mode, see page 16. To use a preset workout, see page 17. To use the iFit training mode, see page 19. To use the sound system, see page 19. To use the information mode, see page 19.

Note: If there is a sheet of plastic on the display, remove the plastic.

HOW TO ACTIVATE THE CONSOLE

The included power adapter can be used to operate the exercise bike. See HOW TO PLUG IN THE POWER ADAPTER on page 13. When the power adapter is plugged in, the displays will turn on and the console will be ready for use.

HOW TO TURN OFF THE CONSOLE

If the pedals do not move for several seconds, a tone will sound and the console will pause.

If the pedals do not move for several minutes and the buttons are not pressed, the console will turn off and the display will be reset.

When you are finished exercising, unplug the power adapter. **IMPORTANT: If you do not do this, the electrical components on the exercise bike may wear prematurely.**

HOW TO USE THE MANUAL MODE

1. Begin pedaling or press any button on the console to turn on the console.

See HOW TO ACTIVATE THE CONSOLE above.

2. Select the manual mode.

Each time you turn on the console, the main menu will appear.

To select the manual mode, press the Increase and Decrease buttons next to the Enter button and highlight START. Then, press the Enter button.

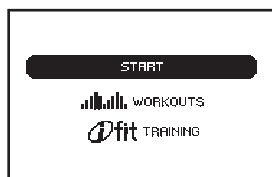

If you have selected a workout or the iFit Training mode, press the Menu button to return to the main menu.

3. Change the resistance of the pedals as desired.

As you pedal, change the resistance of the pedals by pressing the Resistance Increase and Decrease buttons.

Note: After you press the buttons, it will take a moment for the pedals to reach the selected resistance level.

4. Follow your progress with the display.

The console offers several display modes. The display mode that you select will determine which workout information is shown. Press the Display button repeatedly to select the desired display mode.

The display can show the following workout information:

Calories—This display mode will show the approximate number of calories you have burned.

Distance—This display mode will show the distance you have traveled in miles or kilometers.

Profile—When a workout is selected, this display mode will show a profile of the resistance levels for the workout.

Pulse—This display mode will show your heart rate when you use the handgrip pulse sensor (see step 5 on page 17).

Resistance—This display mode will show the resistance level of the pedals for a few seconds each time the resistance level changes.

Speed—This display mode will show your pedaling speed in miles per hour or kilometers per hour.

Target Speed Meter—When a workout is selected, this display mode will compare your pedaling speed to the target pedaling speed and prompt you to increase or decrease your pedaling speed.

Time—When the manual mode is selected, this display mode will show the elapsed time. When a workout is selected, this display mode will show the time remaining in the workout instead of the elapsed time.

Watts—This display will show your power output in watts.

Change the volume level of the console by pressing the Volume Increase and Decrease buttons.

Note: The console can show pedaling speed and distance in either miles or kilometers. To change the unit of measurement, see HOW TO USE THE INFORMATION MODE on page 19.

5. Measure your heart rate if desired.

If there are sheets of plastic on the metal contacts on the handgrip pulse sensor, remove the plastic. To measure your heart rate, hold the handgrip pulse sensor for approximately 15 seconds with your palms resting against the metal contacts. **Avoid moving your hands or gripping the contacts tightly.**

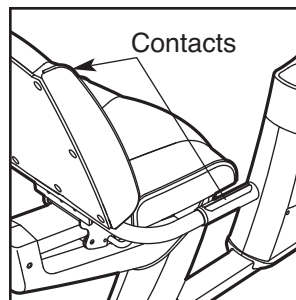

When your pulse is detected, your heart rate will appear in the display. For the most accurate heart rate reading, hold the contacts for at least 15 seconds.

If the display does not show your heart rate, make sure that your hands are positioned as described. Be careful not to move your hands excessively or squeeze the metal contacts tightly. For optimal performance, clean the metal contacts using a soft cloth; **never use alcohol, abrasives, or chemicals to clean the contacts.**

6. When you are finished using the exercise bike, the console will turn off automatically.

See HOW TO TURN OFF THE CONSOLE on page 16.

HOW TO USE A PRESET WORKOUT

1. Begin pedaling or press any button on the console to turn on the console.

See HOW TO ACTIVATE THE CONSOLE on page 16.

2. Select a preset workout.

If you have selected a workout or the iFit Training mode, press the Menu button to return to the main menu.

To select a preset workout, first press the Increase and Decrease buttons next to the Enter button and highlight WORKOUTS. Then, press the Enter button.



Next, press the Increase and Decrease buttons to highlight the desired workout category. Then, press the Enter button.

You can also press the Hill Climbing Workouts button or the Interval Workouts button.

Press the Increase and Decrease buttons to highlight the desired workout category. Then, press the Enter button.

Press the Increase and Decrease buttons to highlight the name of the desired workout. The duration, the maximum speed, the maximum resistance level, and a profile of the resistance levels of the workout will appear in the right side of the display. Then, press the Enter button.

3. Begin pedaling to start the workout.

Each workout is divided into one-minute segments. One resistance level and one target speed are programmed for each segment. Note: The same resistance level and/or target speed may be programmed for consecutive segments.

The workout profile will show your progress. The flashing segment of the profile represents the current segment of the workout. The height of the flashing segment indicates the resistance level for the current segment.

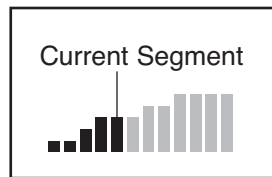

When the first segment of the workout ends, the target speed and the resistance level for the second segment will appear in the display for a few seconds to alert you. The next segment of the profile will begin to flash, and the pedals will automatically adjust to the resistance level for the next segment.

As you exercise, keep your pedaling speed near the target speed for the current segment.

The target speed meter will show your pedaling speed and the target speed for the current segment. When the words **SPEED UP** appear in the target speed meter, increase your pedaling speed. When the words **SLOW DOWN** appear, decrease your pedaling speed.

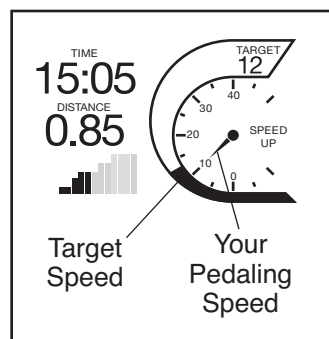

IMPORTANT: The target speed is intended only to provide motivation. Your actual pedaling speed may be slower than the target speed. Make sure to pedal at a speed that is comfortable for you.

If the resistance level for the current segment is too high or too low, you can manually override the setting by pressing the Resistance buttons.

IMPORTANT: When the current segment of the workout ends, the pedals will automatically adjust to the resistance level for the next segment.

The workout will continue in this way until the last segment ends.

To stop the workout at any time, stop pedaling. A tone will then sound. If the time display mode is selected, the time will begin to flash in the display. To restart the workout, simply resume pedaling.

4. Follow your progress with the display.

See in step 4 on page 16.

5. Measure your heart rate if desired.

See step 5 on page 17.

6. When you are finished using the exercise bike, the console will turn off automatically.

See HOW TO TURN OFF THE CONSOLE on page 16.

HOW TO USE THE IFIT TRAINING MODE

The optional iFit Live module allows your console to communicate with your wireless network and unlocks exciting new features. For example, you can download personalized workouts, create your own workouts, track your workout results, and access many other features on the iFit Live website. **To purchase an iFit Live module at any time, go to www.iFit.com or call the telephone number on the front cover of this manual.**

To select the iFit training mode, insert the iFit Live module into the console. Press the Menu button and then press the Increase and Decrease buttons next to the Enter button and highlight IFIT TRAINING. Then, press the Enter button.

For more information about the iFit training mode, go to www.iFit.com. Note: To use the iFit Live module, you must have access to a computer with an internet connection and a USB port. You must also have your own wireless network including an 802.11b router with SSID broadcast enabled (hidden networks are not supported). You will also need an iFit.com membership.

HOW TO USE THE SOUND SYSTEM

To play music or audio books through the console sound system while you exercise, plug the included audio cable into the jack on the console and into a jack on your MP3 player or CD player; **make sure that the audio cable is fully plugged in.**

Next, press the play button on your MP3 player or CD player. Adjust the volume level using the volume control on your MP3 player or CD player or press the Volume Increase and Decrease buttons on the console.

HOW TO USE THE INFORMATION MODE

The console features an information mode that allows you to view usage information for the exercise bike, select a unit of measurement for the console, and adjust the contrast level of the display.

When an iFit Live module is connected to the console, you can also use the information mode to choose an audio setting for the voice of the personal trainer, check the status of the iFit Live module, and check for downloads.

1. Select the information mode.

To select the information mode, press and hold down the Display button for a few seconds until the information mode appears in the display.

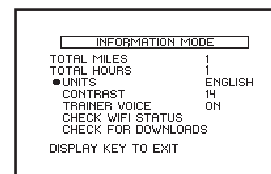

2. View usage information for the exercise bike.

The display will show the total distance that has been pedaled on the exercise bike. The display will also show the total number of hours that the exercise bike has been used.

3. Select a unit of measurement if desired.

The word ENGLISH for English miles or the word METRIC for metric kilometers will appear in the display to indicate the currently selected unit of measurement.

To change the unit of measurement, press the Increase and Decrease buttons until the bullet appears next to the word UNITS. Then, press the Enter button repeatedly to select the desired unit of measurement.

4. Adjust the contrast level of the display if desired.

The currently selected contrast level will also appear in the display. To change the contrast level, press the Increase and Decrease buttons until the bullet appears next to the word CONTRAST.

Press the Enter button and then press the Increase and Decrease buttons repeatedly to select the desired contrast level. Press the Enter button again to save your selection.

5. Determine if an iFit Live module is connected to the console.

If an iFit Live module is connected to the console, the display will show the words WIFI STATUS or USB STATUS.

If no accessory is connected, the display will show the words NO MODULE DETECTED. If no accessory is connected, go to step 9.

6. Select an audio setting for the voice of the personal trainer if desired.

The currently selected audio setting for the voice of the personal trainer will also appear in the display.

To change the audio setting, press the Increase and Decrease buttons until the bullet appears next to the words TRAINER VOICE. Then, press the Enter button repeatedly to turn the voice of the personal trainer ON or OFF.

7. Check the status of the iFit Live module if desired.

To check the status of the iFit Live module, press the Increase and Decrease buttons until the bullet appears next to the words CHECK WIFI STATUS or CHECK USB STATUS.

Then, press the Enter button. After a few seconds, the status of the iFit Live module will appear in the display. To exit this display, press and hold down the Display button for a few seconds.

8. Check for downloads if desired.

To check for iFit Live workouts and firmware downloads, press the Increase and Decrease buttons until the bullet appears next to the words CHECK FOR DOWNLOADS.

Then, press the Enter button. The console will then check for iFit Live workouts and firmware downloads.

9. Exit the information mode.

Press the Display button to exit the information mode.

MAINTENANCE AND TROUBLESHOOTING

Inspect and tighten all parts of the exercise bike regularly. Replace any worn parts immediately.

To clean the exercise bike, use a damp cloth and a small amount of mild soap. **IMPORTANT: To avoid damage to the console, keep liquids away from the console and keep the console out of direct sunlight.**

CONSOLE TROUBLESHOOTING

If the handgrip pulse sensor does not function properly, see step 5 on page 17.

If lines appear in the console display, see step 4 on page 20 and adjust the contrast level of the display.

HOW TO ADJUST THE REED SWITCH

If the console does not display correct feedback, the reed switch should be adjusted.

To adjust the reed switch, first unplug the power adapter. Using a flat screwdriver, release the tabs on the Shield Cover (5) and pull the Shield Cover upward.

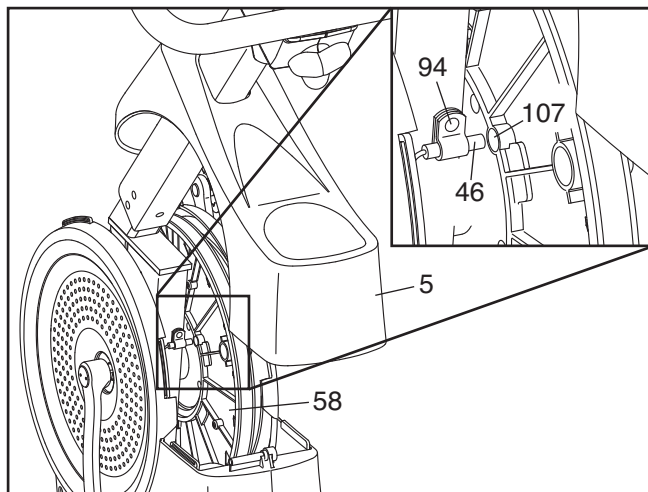

Locate the Reed Switch (46). Turn the Pulley (58) until a Magnet (107) is aligned with the Reed Switch. Next, loosen, but do not remove, the indicated M4 x 13mm Flange Screw (94). Slide the Reed Switch slightly closer to or away from the Magnet, and then retighten the Screw. Turn the Pulley for a moment.

Repeat these actions until the console displays correct feedback. When the reed switch is correctly adjusted, reattach the shield cover.

HOW TO ADJUST THE DRIVE BELT

If the pedals slip while you are pedaling, even while the resistance is adjusted to the highest setting, the drive belt may need to be adjusted.

To adjust the drive belt, first unplug the power adapter. Then, you must first remove the right pedal, the shield cover, and the right front shield.

Using an adjustable wrench, turn the right pedal counterclockwise and remove it.

Next, using a flat screwdriver, release the tabs on the shield Cover (5) and pull the Shield Cover upward.

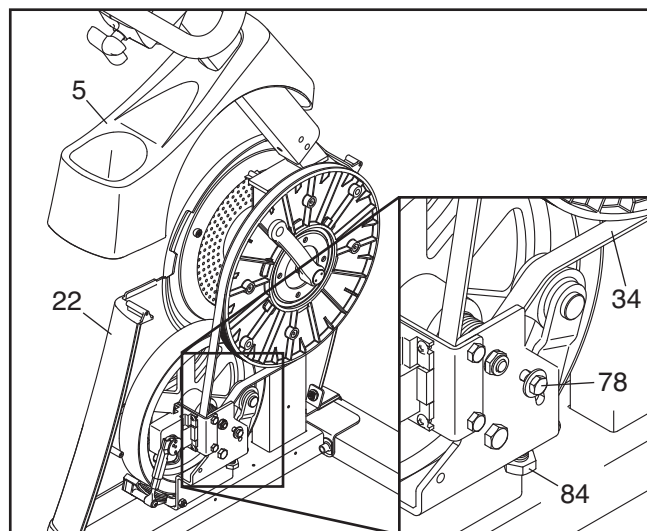

Then, remove all the screws from the Left and Right front shields (22, not shown); **there are three sizes of screws in the Front Shields—note which size of screw you remove from each hole.** Then, gently pull the Right Front Shield away from the frame.

Loosen the M6 x 20mm Hex Screw (78). Tighten the M10 x 50mm Hex Screw (84) until the Drive Belt (34) is tight. When the Drive Belt is tight, tighten the M6 x 20mm Hex Screw.

Then, reattach the front shields, the shield cover, and the right pedal.

EXERCISE GUIDELINES

⚠ WARNING: Before beginning this or any exercise program, consult your physician. This is especially important for persons over age 35 or persons with pre-existing health problems.

The pulse sensor is not a medical device. Various factors may affect the accuracy of heart rate readings. The pulse sensor is intended only as an exercise aid in determining heart rate trends in general.

These guidelines will help you to plan your exercise program. For detailed exercise information, obtain a reputable book or consult your physician. Remember, proper nutrition and adequate rest are essential for successful results.

EXERCISE INTENSITY

Whether your goal is to burn fat or to strengthen your cardiovascular system, exercising at the proper intensity is the key to achieving results. You can use your heart rate as a guide to find the proper intensity level. The chart below shows recommended heart rates for fat burning and aerobic exercise.

165	155	145	140	130	125	115	♥
145	138	130	125	118	110	103	♥
125	120	115	110	105	95	90	♥
<hr/>							
20	30	40	50	60	70	80	

To find the proper intensity level, find your age at the bottom of the chart (ages are rounded off to the nearest ten years). The three numbers listed above your age define your “training zone.” The lowest number is the heart rate for fat burning, the middle number is the heart rate for maximum fat burning, and the highest number is the heart rate for aerobic exercise.

Burning Fat—To burn fat effectively, you must exercise at a low intensity level for a sustained period of time. During the first few minutes of exercise, your body uses *carbohydrate calories* for energy. Only after the first few minutes of exercise does your body begin to use stored *fat calories* for energy. If your goal is to burn fat, adjust the intensity of your exercise until your heart rate is near the lowest number in your training zone. For maximum fat burning, exercise with your heart rate near the middle number in your training zone.

Aerobic Exercise—If your goal is to strengthen your cardiovascular system, you must perform aerobic exercise, which is activity that requires large amounts of oxygen for prolonged periods of time. For aerobic exercise, adjust the intensity of your exercise until your heart rate is near the highest number in your training zone.

WORKOUT GUIDELINES

Warming Up—Start with 5 to 10 minutes of stretching and light exercise. A warm-up increases your body temperature, heart rate, and circulation in preparation for exercise.

Training Zone Exercise—Exercise for 20 to 30 minutes with your heart rate in your training zone. (During the first few weeks of your exercise program, do not keep your heart rate in your training zone for longer than 20 minutes.) Breathe regularly and deeply as you exercise—never hold your breath.

Cooling Down—Finish with 5 to 10 minutes of stretching. Stretching increases the flexibility of your muscles and helps to prevent post-exercise problems.

EXERCISE FREQUENCY

To maintain or improve your condition, complete three workouts each week, with at least one day of rest between workouts. After a few months of regular exercise, you may complete up to five workouts each week, if desired. Remember, the key to success is to make exercise a regular and enjoyable part of your everyday life.

NOTES

PART LIST

Model No. HREX53409.2 R1110A

Key No.	Qty.	Description	Key No.	Qty.	Description
1	1	Frame	46	1	Reed Switch/Wire
2	1	Front Stabilizer	47	1	Idler
3	1	Rear Stabilizer	48	1	Flywheel
4	1	Upright	49	1	Flywheel Axle
5	1	Shield Cover	50	1	Motor Bracket
6	1	Handlebar	51	1	Resistance Motor
7	1	Console	52	1	Motor Disc
8	1	Right Handlebar Cover	53	1	Resistance Arm
9	1	Left Handlebar Cover	54	2	Adjustment Nut
10	1	Seat Bracket	55	1	Resistance Bracket
11	1	Seat Carriage	56	1	Snap Ring
12	1	Pulse Bar	57	1	C-magnet Magnet
13	1	Backrest	58	1	Pulley
14	1	Backrest Cover	59	2	Crank Arm Cap
15	1	Seat	60	10	M8 x 16mm Patch Screw
16	1	Right Pedal/Strap	61	16	M8 Split Washer
17	1	Right Crank Arm	62	4	M10 x 95mm Patch Screw
18	1	Left Pedal/Strap	63	2	M8 x 45mm Patch Screw
19	1	Left Crank Arm	64	2	5/16" Flange Screw
20	1	Crank	65	4	M6 x 50mm Patch Screw
21	1	Right Front Shield	66	17	M6 Washer
22	1	Left Front Shield	67	1	M6 x 70mm Bolt Set
23	1	Right Seat Shield	68	1	M6 x 60mm Bolt Set
24	1	Left Seat Shield	69	8	1/4" x 16mm Patch Screw
25	2	Wheel	70	2	M8 x 20mm Washer
26	1	Right Front Stabilizer Cap	71	2	Handlebar Bushing
27	1	Left Front Stabilizer Cap	72	2	Upright Bushing
28	2	Rear Stabilizer Cap	73	4	M8 x 20mm Button Bolt
29	2	Leveling Knob	74	4	M8 Locknut
30	2	Leveling Foot	75	2	M6 x 8mm Hex Screw
31	4	Foot/Bumper	76	1	M3.5mm x 12mm Screw
32	1	Knob	77	1	M6 x 14.67mm Shoulder Screw
33	1	Brake	78	1	M6 x 20mm Hex Screw
34	1	Drive Belt	79	1	M6 x 65mm Hex Bolt
35	1	Seat Lever	80	1	M6 Locknut
36	1	Seat Handle	81	4	M4 x 12mm Flange Screw
37	1	Seat Lever Bracket	82	1	M5 x 7mm Screw
38	4	Axle	83	1	M5 Washer
39	2	Upper Roller	84	1	M10 x 50mm Hex Screw
40	2	Lower Roller	85	2	Brake Spacer
41	2	Pulse Grip	86	2	M8 Jam Nut
42	2	Handlebar Cap	87	10	Fastener
43	2	Bearing	88	28	M4 x 19mm Screw
44	2	Snap Ring	89	1	Wire Harness
45	1	Clamp	90	1	Audio Cable

Key No.	Qty.	Description	Key No.	Qty.	Description
91	1	Frame Pulse Wire/Receptacle	102	1	M6 x 18mm Washer
92	1	Pulse Bar Pulse Wire	103	10	M6 Split Washer
93	4	M6 x 20mm Flat Head Screw	104	1	Power Adapter
94	1	M4 x 13mm Flange Screw	105	2	Seat Carriage Cap
95	1	M4 x 13mm Bright Screw	106	4	Wire Clamp
96	2	1/4" x 14mm Patch Screw	107	2	Magnet
97	3	M6 x 16mm Screw	108	1	M4 x 16mm Phillips Screw
98	8	M4 x 16mm Screw	*	–	User's Manual
99	2	M4 x 12mm Screw	*	–	Assembly Tool
100	3	M4 x 25mm Screw	*	–	Grease Packet
101	1	Snap Fastener			

Note: Specifications are subject to change without notice. For information about ordering replacement parts, see the back cover of this manual. *These parts are not illustrated.

EXPLODED DRAWING A

Model No. HREX53409.2 R1110A

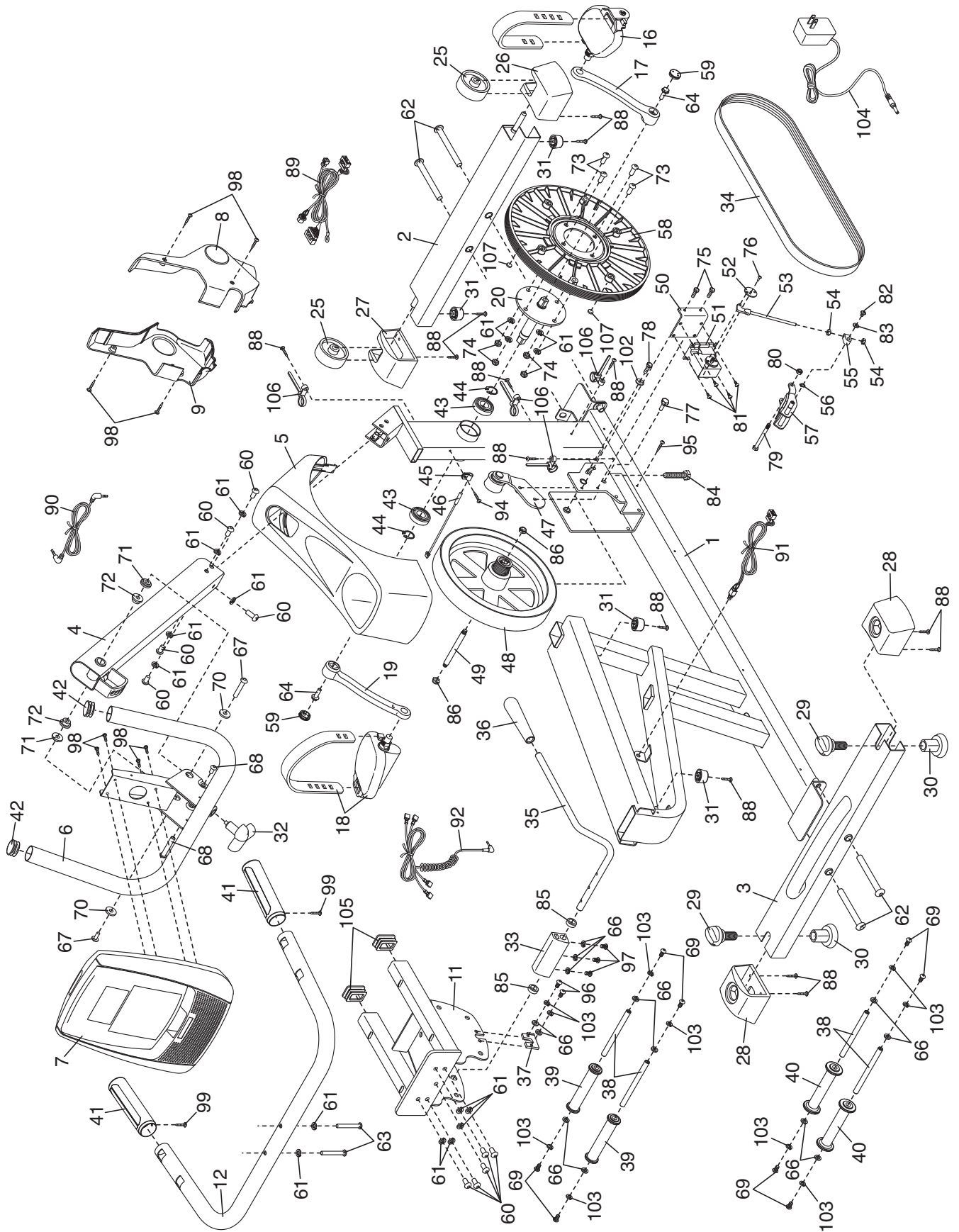

EXPLODED DRAWING B

Model No. HREX53409.2 R1110A

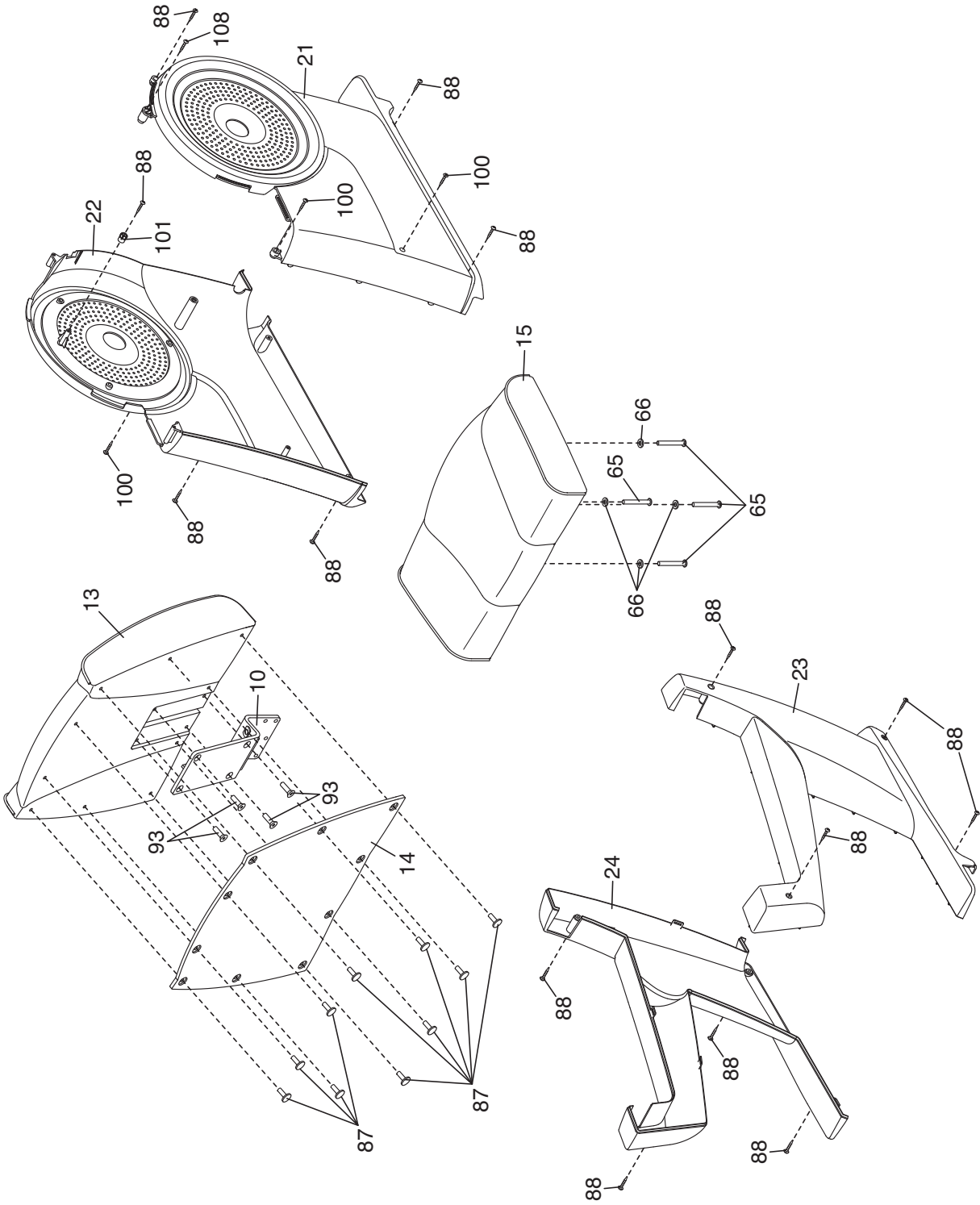

ORDERING REPLACEMENT PARTS

To order replacement parts, please see the front cover of this manual. To help us assist you, be prepared to provide the following information when contacting us:

- the model number and serial number of the product (see the front cover of this manual)
- the name of the product (see the front cover of this manual)
- the key number and description of the replacement part(s) (see the PART LIST and the EXPLODED DRAWING near the end of this manual)

LIMITED WARRANTY

IMPORTANT: You must register this product within 30 days of the purchase date to avoid added fees for service needed under warranty. Go to www.healthriderservice.com/registration.

ICON Health & Fitness, Inc. (ICON) warrants this product to be free from defects in workmanship and material, under normal use and service conditions. The frame is warranted for five (5) years from the date of purchase. Parts and labor are warranted for ninety (90) days from the date of purchase.

This warranty extends only to the original purchaser. ICON's obligation under this warranty is limited to repairing or replacing, at ICON's option, the product through one of its authorized service centers. All repairs for which warranty claims are made must be preauthorized by ICON. If the product is shipped to a service center, freight charges to and from the service center will be the customer's responsibility. For replacement parts shipped while the product is under warranty, the customer will be responsible for a minimal handling charge. For in-home service, the customer will be responsible for a minimal trip charge. This warranty does not extend to any damage to a product caused by or attributable to freight damage, abuse, misuse, improper or abnormal usage, or repairs not provided by an ICON authorized service center; to products used for commercial or rental purposes or as store display models; or to products transported or purchased outside the US. No other warranty beyond that specifically set forth above is authorized by ICON.

ICON is not responsible or liable for indirect, special, or consequential damages arising out of or in connection with the use or performance of the product; damages with respect to any economic loss, loss of property, loss of revenues or profits, loss of enjoyment or use, or costs of removal or installation; or other consequential damages of whatsoever nature. Some states do not allow the exclusion or limitation of incidental or consequential damages. Accordingly, the above limitation may not apply to you.

The warranty extended hereunder is in lieu of any and all other warranties, and any implied warranties of merchantability or fitness for a particular purpose are limited in their scope and duration to the terms set forth herein. Some states do not allow limitations on how long an implied warranty lasts. Accordingly, the above limitation may not apply to you.

This warranty gives you specific legal rights. You may also have other rights that vary from state to state.

ICON Health & Fitness, Inc., 1500 S. 1000 W., Logan, UT 84321-9813