

USE AND CARE GUIDE

VIDEO MOTION SECURITY LIGHT

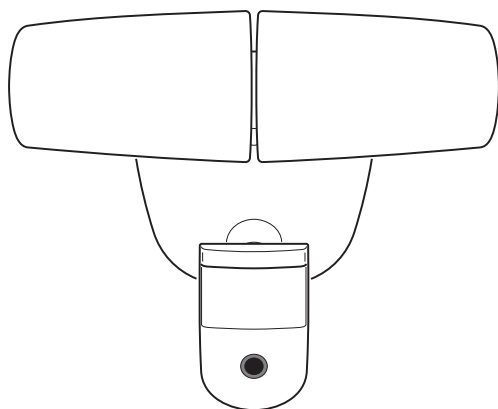

Questions, problems, missing parts?

Before returning to the store, call Defiant Customer Service
8 a.m.-7 p.m., EST, Monday-Friday, 9 a.m. - 6 p.m., EST, Saturday

1-866-308-3976

HOMEDEPOT.COM

THANK YOU

We appreciate the trust and confidence you have placed in Defiant through the purchase of this video motion security light. We strive to continually create quality products designed to enhance your home. Visit us online to see our full line of products available for your home improvement needs. Thank you for choosing Defiant!

Table of Contents

Table of Contents	2	Tools Required	4
Safety Information	2	Hardware Included	5
Warranty	3	Package Contents	5
5-Year Limited Warranty	3	Installation	6
Pre-Installation	3	Operation	8
Planning Installation	3	Care and Cleaning	12
Specifications	3	Troubleshooting	13

Safety Information

PRECAUTIONS

- Please read and understand this entire manual before attempting to assemble, install, or operate this light fixture.
- This light fixture requires a 120-Volt AC power source.
- Some codes require installation by a qualified electrician.
- This light fixture must be properly grounded.
- This light fixture should be installed outdoors to a wall or eave.
- The light fixture should be mounted approximately 8 ft. (2.4 m) above the ground. If the light fixture is mounted higher than recommended, aiming the sensor down will reduce the coverage area.
- The light fixture/camera requires constant power to operate. Whenever the power is turned on to the light fixture (either for the first time or after a power outage), the light requires a 60-second boot-up period before the camera will be fully operational.
- Many states regulate the use of security cameras and other recording devices. It is the purchaser's sole responsibility to ensure compliance with all applicable laws and to provide any legally required notices. Check local laws regarding the use of any recording devices and cameras prior to installation.



WARNING: Turn the power off at the circuit breaker or fuse. Place tape over the circuit breaker switch and verify power is off at the light fixture.



WARNING: Risk of fire. Keep the lamp heads at least 2 in. (51 mm) from combustible materials.



CAUTION: Burn hazard. Allow the light fixture to cool before touching.

NOTICE: Do not connect this light fixture to a dimmer switch or timer.

- This device complies with Part 15 of the FCC Rules. Operation is subject to the following two conditions: (1) this device may not cause harmful interference, and (2) this device must accept any interference received, including interference that may cause undesired operation.
- This device complies with Industry Canada licence-exempt RSS standard(s). Operation is subject to the following two conditions: (1) this device may not cause interference, and (2) this device must accept any interference, including interference that may cause undesired operation of the device.
- CAN ICES-3 (B)/NMB-3(B)

Warranty

5-YEAR LIMITED WARRANTY

WHAT IS COVERED

This product is guaranteed to be free of factory defective parts and workmanship for a period of 5 years from date of purchase. Purchase receipt is required for all warranty claims.

WHAT IS NOT COVERED

This guarantee does not include repair service, adjustment and calibration due to misuse, abuse or negligence, or LEDs. Unauthorized service or modification of the product or of any furnished component will void this warranty in its entirety. This warranty does not include reimbursement for inconvenience, installation, setup time, loss of use, unauthorized service, or return shipping charges. This warranty is not extended to other equipment and components that a customer uses in conjunction with this product.

No service parts available for this product.

Contact the Customer Service Team at 1-866-308-3976 or visit www.homedepot.com.

Pre-Installation

PLANNING INSTALLATION

Before installing the light fixture, ensure that all parts are present. Compare parts with the *Hardware Included* and *Package Contents* sections. If any part is missing or damaged, do not attempt to assemble, install, or operate this light fixture.

Estimated installation time: 30 minutes

SPECIFICATIONS

Range	Up to 70 ft. (21.3 m) (Varies with surrounding temperature)
PIR motion sensing angle	Up to 180°
Electrical load - LED	34 Watts
Lumens	2350
Power requirements	120 VAC, 60 Hz
Video resolution	Hi: 1280 x 720 (720p), Med: 640 x 360, Low: 320 x 180
Video frame rate	Adjustable up to 25 fps (Default - 15 fps)
Video viewing angle	Up to 100°
Operating temperature	-13°F to +120°F (-25°C to +50°C)
Mobile device requirements	iPhone and Android compatible. See Homedepot.com for system requirements.

Pre-Installation (continued)

TOOLS REQUIRED



Phillips
screwdriver



1/8 in. Flathead
screwdriver



Wire strippers/
cutters



Circuit tester



Work gloves



Silicone
sealant



Ladder



Safety goggles



Mobile Device

Pre-Installation (continued)

HARDWARE INCLUDED



NOTE: Hardware shown to actual size.

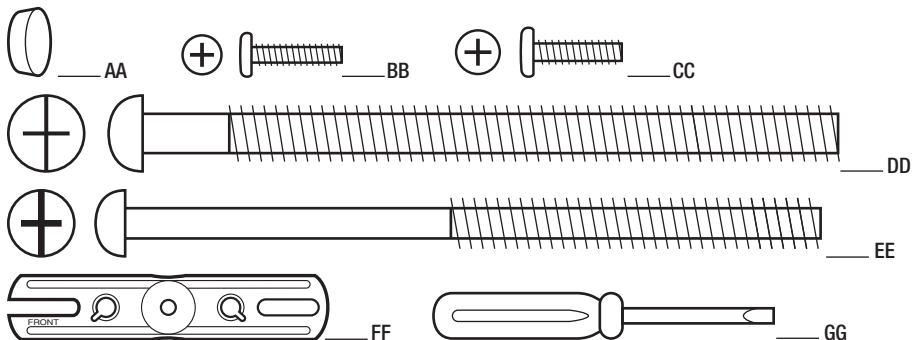

Part	Description	Quantity
AA	Rubber plug	1
BB	Mounting bracket screw	2
CC	Mounting bracket screw	2
DD	Large mounting bolt	1
EE	Small mounting bolt (pre-installed)	1
FF	Mounting bracket (not to scale)	1
GG	Mini screwdriver	1

PACKAGE CONTENTS

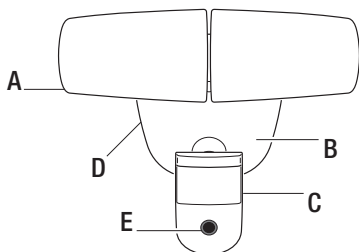

Part	Description	Quantity
A	Lamp head	2
B	Light fixture	1
C	Motion sensor	1
D	Mounting plate	1
E	Camera	1

Installation

1 Determining the mounting location



NOTE: The light fixture should be mounted approximately 8 ft. (2.4 m) above the ground. If the light fixture is mounted higher than recommended, aiming the sensor down will reduce the coverage area.

- Determine the mounting location – wall or eave mount.
- Position the lamp heads (A) in the general direction of the desired light coverage.
- If needed, rotate the motion sensor (C) so the text faces upward.

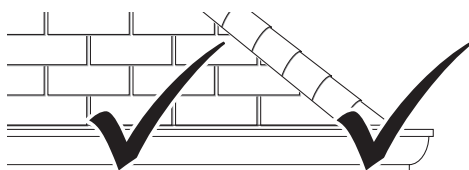

Wall Mount

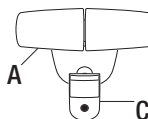

Eave Mount

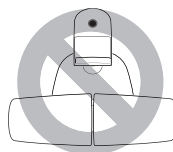
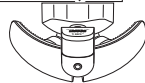

2 Removing the mounting plate



NOTE: This fixture comes with a mounting plate (D). It is pre-assembled on the light fixture (B) for shipping.



NOTE: The small mounting bolt (EE) is pre-installed in the light fixture (B). Do not attempt to remove the small mounting bolt (EE).

- Unscrew the small mounting bolt (EE) connecting the light fixture (B) to the mounting plate (D) and remove the mounting plate (D).

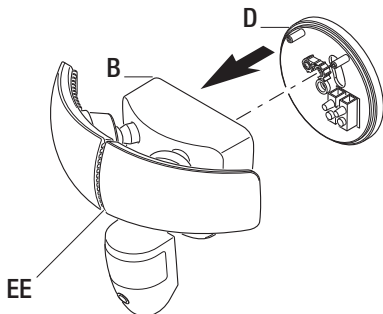

3 Installing the mounting bracket



WARNING: Turn the power off at the circuit breaker or fuse. Place tape over the circuit breaker switch and verify power is off at the light fixture.



NOTE: Six mounting bracket screws of various sizes are included. The installation will only require two. Discard the unused mounting bracket screws after installation.

- Remove the existing light fixture.
- Install the mounting bracket (FF) with the stamped word “FRONT” facing away from the junction box. Use the mounting bracket screws (BB or CC) that best fit the junction box.
- Firmly pull on the mounting bracket to verify it is securely mounted to the junction box. If necessary, use the screws that were removed from the existing light fixture.

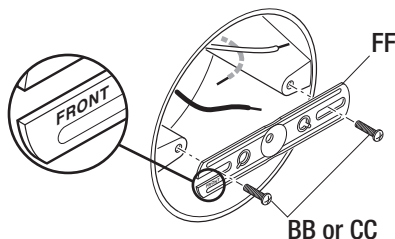

Installation (continued)

4 Installing the mounting plate

- Route the junction box wires through the hole in the mounting plate (D).
- Place the mounting plate (D) against the junction box.
 - When mounting to a wall, the “UP” arrow must point upward.
 - When mounting to an eave, the “UP” arrow must point toward the building.
- Insert the large mounting bolt (DD) through the mounting plate (D) hole located below the threaded hole, and thread it into the center hole of the mounting bracket (FF). Tighten the bolt (DD) securely.
- Firmly pull on the mounting plate (D) to verify it is securely attached to the mounting bracket (FF).

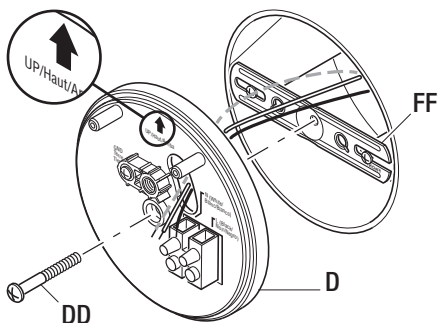

5 Making the electrical connections

- Insert the junction box wires into the side of the terminal block and around the ground screw. Tighten terminal block screws using the mini-screwdriver (GG) and ground screw to secure the wires.
- Insert the white wire from the junction box into the terminal marked “N (White)”.
 - Insert the black wire from the junction box into the terminal marked “L (Black)”.
- Connect the bare or green ground wire from the junction box to the ground screw (marked with “GND”).

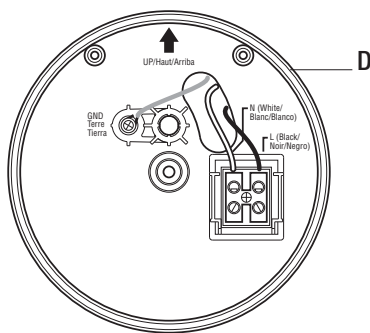

6 Mounting the light fixture

NOTICE: The two pins on the rear of the light fixture must be inserted into the terminal block for the light to work.

- Align the bottom edge of the light fixture (B) with the bottom edge of the mounting plate (D). Tilt the light fixture (B) toward the mounting plate (D), making sure the light fixture (B) is centered on the mounting plate (D).
- Tighten the small mounting bolt (EE) securely through the center of the mounting plate (D). Do not overtighten.
- Push the rubber plug (AA) firmly into the mounting bolt hole on the light fixture (B).

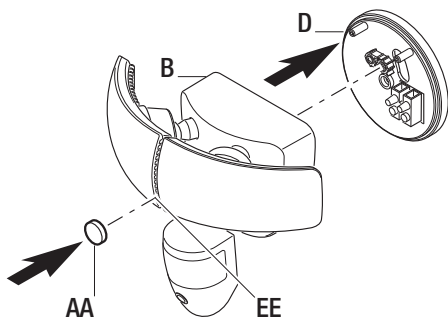

Installation (continued)

7 Caulking around the light fixture

- Caulk around the mounting plate (D) and mounting surface with silicone sealant (not included).

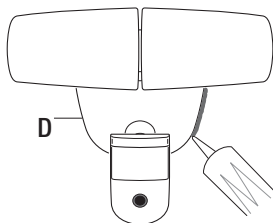

Operation

1 Adjusting the lamp heads



WARNING: Risk of fire. Keep the lamp heads at least 2 in. (51 mm) from combustible materials.



CAUTION: Keep lamp heads 30° below horizontal to avoid water damage and electrical shock.

- Turn the power on at the circuit breaker or fuse and turn on the wall switch.
- If needed, gently grasp the lamp heads (A) and tilt them up or down or side to side to adjust the light coverage area.

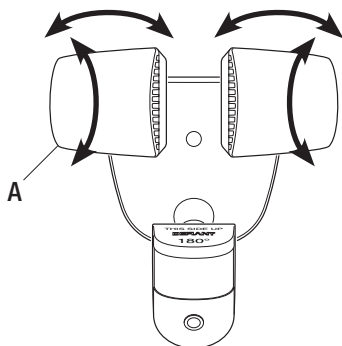

2 Rotating the sensor controls downward

- Rotate the motion sensor (C) so the text faces upward.

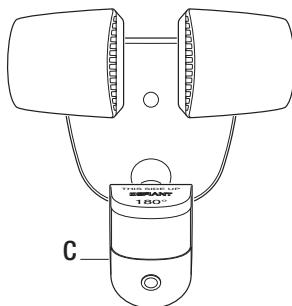



3 Downloading the mobile app

- Download the Notifi™ mobile app. Search for the “Notifi Video Solutions” app.
- iOS Devices – Download the app from the App StoreSM.
- Android Devices – Download the app from the Google Play™ store.

5 Viewing live video

The Notifi app provides live-stream video from the camera to a mobile device.

- Tap the name of the camera to be viewed.
- While in the live-stream screen, the following options are available:
 - Tap the video camera icon () to start recording live video. Tap again to stop recording.
 - Tap the camera icon () to save a still image from the live-stream video.
- To return to the main app screen, tap the () or “Back” button in the top left corner.



NOTE: All videos and images will be saved to the mobile device currently being used to view the live-stream video.

4 Connecting the light to the mobile app

NOTICE: The network password will be required to complete this process.

- Ensure the power to the light is turned ON. Allow 60 seconds for system boot-up.
- On the mobile device, go to *Settings* > *Wi-Fi* and select “Notifi_Video_SecurityXXXX” (“XXXX” represents the unique MAC address of each light fixture) from the available Wi-Fi networks.
- Once connected, open the Notifi app. The app will detect the new light.
- Select “Yes” to start the setup and the app will guide you through the remaining steps.



NOTE: When creating a new Notifi account, the username and password must be a minimum of 4 characters and a maximum of 12 characters. Alpha-numeric and/or special characters may be used.

6 Understanding the motion detection process

This light has dual motion detection technologies.

- The light is controlled by a 180° PIR (passive infra-red) sensor. This sensor detects a temperature difference moving in front of it. When motion is detected after dark, the light will come on at the selected “Full Bright Intensity” level.
- The camera uses both the 180° PIR sensor as well as a 100° image sensor located within the camera software. The camera’s image sensor will not activate unless the PIR sensor first detects a moving temperature difference within the detection zone. The camera will record motion day or night.

7 Using the event list

Tap the Events tab.

An event is created each time the camera senses motion.

- Basic Service – The event list will show the date and time the motion was detected.
- Premium Service (available for an additional fee) – The event list will include the date, time, and video of the event each time motion was detected. The video of each event will also be available to download for 30 days.

9 Adjusting the light settings

The light settings allow you to adjust the full bright duration, the DualBrite® duration, and the percentages of light intensity.



NOTE: Changes made to one light's settings will not affect another light's settings.

Tap  > Feature Settings > Light to select the light settings.

- Full Bright Duration – This adjusts the amount of time the light will stay ON after all motion has stopped.
- DualBrite Duration – This adjusts the amount of time the light stays ON at a reduced brightness level when no motion is detected.
- Full Bright Intensity – This adjusts the intensity level of the light when motion is detected.
- DualBrite Dimming Level – This adjusts the intensity level of the light when no motion is detected.

8 Receiving notifications

Tap  > Feature Settings > Notifications to select the notification settings.

If notifications are turned on, an email and/or push notification is sent each time the camera senses motion. Tap on the notification to be taken to the live-view video screen (Basic service) or the Event video (Premium service).

10 Adjusting the camera settings

The camera settings allow you to adjust the motion detection sensitivity, motion detection zones, and video quality.



NOTE: Changes made to one camera's settings will not affect another camera's settings.



NOTE: The higher the "Sensitivity" setting, the greater the possibility of false triggering. To reduce false triggering, select a lower setting.

Tap  > Feature Settings > Camera to select the camera settings.

- Motion Detection – This adjusts the camera's sensitivity to motion in its field of view.
- Motion Detection Zones – This adjusts the camera's detection area to include or exclude zones in its field of view.
- Auto Adjust – Disabling this setting allows manual adjustments of the video's quality settings. For best performance, leave the Auto Adjust ON.

11 Setting the sensor for testing



NOTE: The light fixture will operate during the day or night during testing. The light will stay on for 5 seconds after all motion is stopped.



NOTE: The light requires a 60-second boot-up period before the camera will be fully operational.

Tap > Feature Settings > Camera > Motion Detection to select the motion detection settings.

The light fixture will automatically enter “Test” mode whenever the “Motion Detection” option is selected. The light fixture will remain in “Test” until one of the following actions occurs:

- The “Save” or “Cancel” option is selected.
- No movement during the testing process for 30 seconds.
- Three minutes have passed without changing one of the on-screen settings.

12 Adjusting the motion sensor detection zone



NOTE: The camera's (E) detection zone is inside of the light's detection zone. When the motion sensor (C) for the light is adjusted, the camera's (E) motion sensor will also be adjusted.

If motion is detected outside the camera's detection zone, the light may turn on but the camera will not record an event.

- Perform a “walk test”: walk in an arc across the front of the motion sensor (C).
- Watch the light. The light will come on and the red LED will flash indicating motion has been detected.
- Stop, wait for the light to turn off, and then begin walking again.
- Continue this process until the detection zone has been established.
- If needed, gently grasp the motion sensor (C) and move it from side to side or up and down to adjust the detection zone.
- Adjust the “Motion Detection” sensitivity to High, Medium, or Low as needed.



NOTE: The motion sensor (C) is more sensitive to motion moving across the front of the sensor. The motion sensor (C) is less sensitive to motion moving directly toward the front of the sensor.

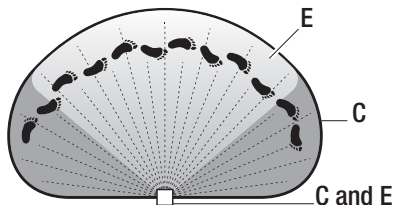

Operation (continued)

13 Adding multiple users

The Notifi system allows control of multiple users within an account.

Tap  > Advanced Settings > Manage Multiple Users.

- Tap the “Add Viewers” button and type the email address in the “To:” field.
- Tap the “Send” button.



NOTE: When adding multiple users, separate the email addresses with a semicolon.

14 Adding system name and photo

Add a name and photo to represent the Notifi system on the mobile device. The photo will be placed inside the blue circle icon next to the selected Notifi system.

Tap  > Advanced Settings > System Name/Photo.

- Enter a name for the Notifi system.
- Select an existing photo and take a new photo to represent the Notifi system.



NOTE: The light settings and name are stored in the light fixture. The photo is locally stored on the mobile device and is only visible on that device.

15 Using manual mode

Manual mode overrides the motion sensor (C) and will turn the light on at the preset “Full Bright Intensity” level. This feature works day or night. The motion sensor (C) will reset to motion sensing mode at sunrise.

- On the main screen under the “Systems” tab, choose “ON”, “OFF”, or “AUTO” to control the lights for the selected Notifi system.

16 Deleting a Notifi system

To delete a Notifi system from an account:

- Turn off the wall switch controlling the Notifi system.
- On the main “Systems” screen, wait for the system to go offline (the system name and image will turn gray).
- Once offline, swipe the Notifi system to be deleted to the left and tap the trashcan icon ().

Care and Cleaning

- To prolong the original appearance, clean the light fixture with clear water and a soft, damp cloth only.
- Do not use paints, solvents, or other chemicals on this light fixture. They could cause a premature deterioration of the finish. This is not a defect in the finish and will not be covered by the warranty.
- Do not spray the light fixture with a hose or power washer.
- To clean the camera lens, use a dry, microfiber cloth only.

Troubleshooting

Problem	Possible Cause	Solution
The light will not come on.	<ul style="list-style-type: none"> <input type="checkbox"/> The light switch is turned off. <input type="checkbox"/> The fuse is blown or the circuit breaker is turned off. <input type="checkbox"/> The light is not scheduled to come ON. <input type="checkbox"/> The circuit wiring is incorrect (if this is a new installation). <input type="checkbox"/> The motion sensor is aimed in the wrong direction. <input type="checkbox"/> The outside air temperature is close to the same as a person's body heat. 	<ul style="list-style-type: none"> <input type="checkbox"/> Turn the light switch on. <input type="checkbox"/> Replace the fuse or turn the circuit breaker on. <input type="checkbox"/> Recheck the light operation during the scheduled "DualBrite Duration" (after sunset). <input type="checkbox"/> Verify the wiring is correct. <input type="checkbox"/> Re-aim the motion sensor to cover the desired area. <input type="checkbox"/> Increase the "Motion Detection" setting.
The light comes on during the day.	<ul style="list-style-type: none"> <input type="checkbox"/> The light is scheduled to come ON. 	<ul style="list-style-type: none"> <input type="checkbox"/> Adjust the scheduled light operation in "DualBrite Duration."
The light comes on for no apparent reason.	<ul style="list-style-type: none"> <input type="checkbox"/> The motion sensor may be sensing small animals or automobile traffic. <input type="checkbox"/> The "Motion Detection" setting is set too high. <input type="checkbox"/> The "DualBrite Duration" is operating at the preset "DualBrite Dimming Level" setting. <input type="checkbox"/> The outside temperature is much warmer or cooler than a person's body heat (summer or winter). <input type="checkbox"/> The light fixture is wired through a dimmer or timer. 	<ul style="list-style-type: none"> <input type="checkbox"/> Decrease the "Motion Detection" setting or reposition the motion sensor. <input type="checkbox"/> Decrease the "Motion Detection" setting. <input type="checkbox"/> The light fixture is operating normally under these circumstances. The "DualBrite Duration" time is adjustable. <input type="checkbox"/> Decrease the "Motion Detection" setting. <input type="checkbox"/> Do not use a dimmer or timer to control the light fixture. Replace the dimmer or timer with a standard on/off wall switch.
The lights stay ON too late in the "DualBrite Duration" setting.	<ul style="list-style-type: none"> <input type="checkbox"/> The "DualBrite Duration" OFF time is set to late. 	<ul style="list-style-type: none"> <input type="checkbox"/> Adjust the "DualBrite Duration" OFF time to the desired setting.
The lights do not stay ON late enough in the "DualBrite Duration" setting.	<ul style="list-style-type: none"> <input type="checkbox"/> The "DualBrite Duration" OFF time is set to early. 	<ul style="list-style-type: none"> <input type="checkbox"/> Adjust the "DualBrite Duration" OFF time to the desired setting.

Troubleshooting (continued)

Problem	Possible Cause	Solution
The lights stay on continuously.	<ul style="list-style-type: none"> □ The motion sensor may be picking up a heat source, such as an air vent, dryer vent, or brightly painted, heat-reflective surface. □ The motion sensor is in manual mode. □ The light fixture is wired through a dimmer or timer. □ The light fixture is on the same circuit as a motor, transformer, or fluorescent bulb. 	<ul style="list-style-type: none"> □ Decrease the “Motion Detection” setting or reposition the motion sensor. □ Turn the manual mode option to Off or Auto. See <i>Using manual mode</i> on page 12. □ Do not use a dimmer or timer to control the light fixture. Replace the dimmer or timer with a standard on/off wall switch. □ Install the light fixture on a circuit without motors, transformers, or fluorescent bulbs.
The lights flash on and off.	<ul style="list-style-type: none"> □ Heat or light from the lamp heads may be turning the motion sensor on and off. □ Heat is being reflected from other objects and may be turning the motion sensor on and off. 	<ul style="list-style-type: none"> □ Reposition the lamp heads away from the motion sensor. □ Decrease the “Motion Detection” setting or reposition the motion sensor.
The light fixture is not responding to the app.	<ul style="list-style-type: none"> □ The light is offline (the system name and image are gray). □ The light is unable to connect to the wi-fi (the system name and image are gray). 	<ul style="list-style-type: none"> □ Ensure the light has power. □ Ensure the light is connected to the wi-fi router. □ Turn the power to the light off. Wait 30 seconds and turn the power on. Wait 60 seconds for the light to boot-up.
The app is not finding the light fixture.	<ul style="list-style-type: none"> □ The light may have been deleted from the account. 	<ul style="list-style-type: none"> □ Reconnect the light to the app (see step 4, page 9).
Motion notifications are not being sent to the app.	<ul style="list-style-type: none"> □ Notifications are turned off in the app. □ Motion is not being detected inside the camera’s detection zone. 	<ul style="list-style-type: none"> □ Turn notifications on in the app (see step 8, page 10). □ Re-aim the motion sensor to cover the desired area or increase the “Motion Detection” setting.

DEFIANT®

**Questions, problems, missing parts?
Before returning to the store, call Defiant Customer Service
8 a.m.-7 p.m., EST, Monday-Friday, 9 a.m. - 6 p.m., EST, Saturday**

1-866-308-3976

HOMEDEPOT.COM

Retain this manual for future use.

Apple and the Apple logos are trademarks of Apple Inc., registered in the U.S., and other countries. App Store is a service mark of Apple Inc.

Google Play is a trademark of Google Inc.

Android is a trademark of Google Inc.

Wi-Fi® is a registered trademark of Wi-Fi Alliance

DEFIANT®

Item #1001814036
Model #DFI-5892-WH

USE AND CARE GUIDE

VIDEO MOTION SECURITY LIGHT

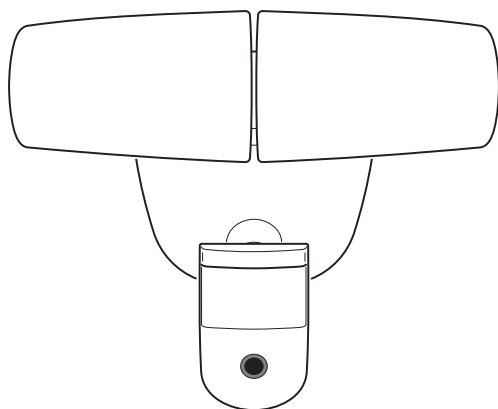

Questions, problems, missing parts?

**Before returning to the store, call Defiant Customer Service
8 a.m.-7 p.m., EST, Monday-Friday, 9 a.m. - 6 p.m., EST, Saturday**

1-866-308-3976

HOMEDEPOT.COM

THANK YOU

We appreciate the trust and confidence you have placed in Defiant through the purchase of this video motion security light. We strive to continually create quality products designed to enhance your home. Visit us online to see our full line of products available for your home improvement needs. Thank you for choosing Defiant!

Table of Contents

Table of Contents	2	Tools Required	4
Safety Information	2	Hardware Included	5
Warranty	3	Package Contents	5
5-Year Limited Warranty	3	Installation	6
Pre-Installation	3	Operation	8
Planning Installation	3	Care and Cleaning	12
Specifications	3	Troubleshooting	13

Safety Information

PRECAUTIONS

- Please read and understand this entire manual before attempting to assemble, install, or operate this light fixture.
- This light fixture requires a 120-Volt AC power source.
- Some codes require installation by a qualified electrician.
- This light fixture must be properly grounded.
- This light fixture should be installed outdoors to a wall or eave.
- The light fixture should be mounted approximately 8 ft. (2.4 m) above the ground. If the light fixture is mounted higher than recommended, aiming the sensor down will reduce the coverage area.
- The light fixture/camera requires constant power to operate. Whenever the power is turned on to the light fixture (either for the first time or after a power outage), the light requires a 60-second boot-up period before the camera will be fully operational.
- Many states regulate the use of security cameras and other recording devices. It is the purchaser's sole responsibility to ensure compliance with all applicable laws and to provide any legally required notices. Check local laws regarding the use of any recording devices and cameras prior to installation.



WARNING: Turn the power off at the circuit breaker or fuse. Place tape over the circuit breaker switch and verify power is off at the light fixture.



WARNING: Risk of fire. Keep the lamp heads at least 2 in. (51 mm) from combustible materials.



CAUTION: Burn hazard. Allow the light fixture to cool before touching.

NOTICE: Do not connect this light fixture to a dimmer switch or timer.

- This device complies with Part 15 of the FCC Rules. Operation is subject to the following two conditions: (1) this device may not cause harmful interference, and (2) this device must accept any interference received, including interference that may cause undesired operation.
- Le présent appareil est conforme aux CNR d'Industrie Canada applicables aux appareils radio exempts de licence. L'exploitation est autorisée aux deux conditions suivantes : (1) l'appareil ne doit pas produire de brouillage, et (2) l'utilisateur de l'appareil doit accepter tout brouillage radioélectrique subi, même si le brouillage est susceptible d'en compromettre le fonctionnement.
- CAN ICES-3 (B)/NMB-3(B)

Warranty

5-YEAR LIMITED WARRANTY

WHAT IS COVERED

This product is guaranteed to be free of factory defective parts and workmanship for a period of 5 years from date of purchase. Purchase receipt is required for all warranty claims.

WHAT IS NOT COVERED

This guarantee does not include repair service, adjustment and calibration due to misuse, abuse or negligence, or LEDs. Unauthorized service or modification of the product or of any furnished component will void this warranty in its entirety. This warranty does not include reimbursement for inconvenience, installation, setup time, loss of use, unauthorized service, or return shipping charges. This warranty is not extended to other equipment and components that a customer uses in conjunction with this product.

No service parts available for this product.

Contact the Customer Service Team at 1-866-308-3976 or visit www.homedepot.com.

Pre-Installation

PLANNING INSTALLATION

Before installing the light fixture, ensure that all parts are present. Compare parts with the *Hardware Included* and *Package Contents* sections. If any part is missing or damaged, do not attempt to assemble, install, or operate this light fixture.

Estimated installation time: 30 minutes

SPECIFICATIONS

Range	Up to 70 ft. (21.3 m) (Varies with surrounding temperature)
PIR motion sensing angle	Up to 180°
Electrical load - LED	34 Watts
Lumens	2350
Power requirements	120 VAC, 60 Hz
Video resolution	Hi: 1280 x 720 (720p), Med: 640 x 360, Low: 320 x 180
Video frame rate	Adjustable up to 25 fps (Default - 15 fps)
Video viewing angle	Up to 100°
Operating temperature	-13°F to +120°F (-25°C to +50°C)
Mobile device requirements	iPhone and Android compatible. See Homedepot.com for system requirements.

Pre-Installation (continued)

TOOLS REQUIRED



Phillips
screwdriver



1/8 in. Flathead
screwdriver



Wire strippers/
cutters



Circuit tester



Work gloves



Silicone
sealant



Ladder



Safety goggles



Mobile Device

Pre-Installation (continued)

HARDWARE INCLUDED



NOTE: Hardware shown to actual size.

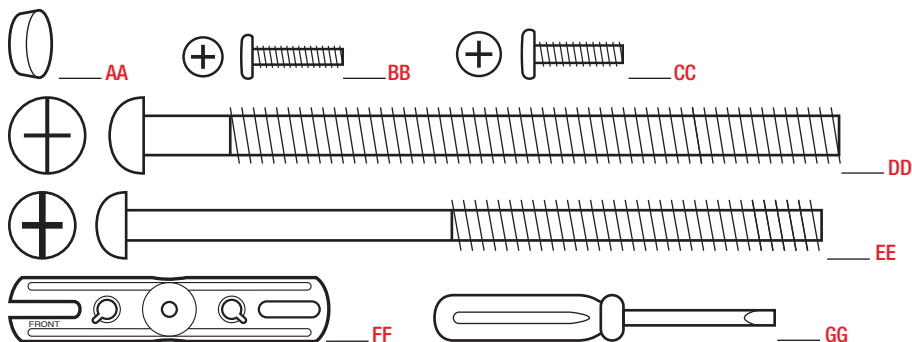

Part	Description	Quantity
AA	Rubber plug	1
BB	Mounting bracket screw	2
CC	Mounting bracket screw	2
DD	Large mounting bolt	1
EE	Small mounting bolt (pre-installed)	1
FF	Mounting bracket (not to scale)	1
GG	Mini screwdriver	1

PACKAGE CONTENTS

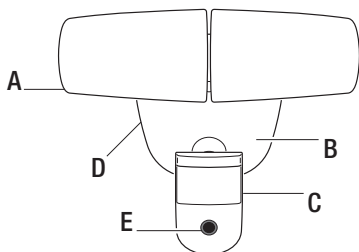

Part	Description	Quantity
A	Lamp head	2
B	Light fixture	1
C	Motion sensor	1
D	Mounting plate	1
E	Camera	1

Installation

1 Determining the mounting location



NOTE: The light fixture should be mounted approximately 8 ft. (2.4 m) above the ground. If the light fixture is mounted higher than recommended, aiming the sensor down will reduce the coverage area.

- Determine the mounting location – wall or eave mount.
- Position the lamp heads (A) in the general direction of the desired light coverage.
- If needed, rotate the motion sensor (C) so the text faces upward.

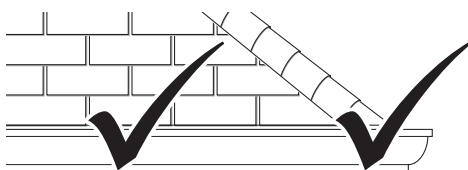

Wall Mount

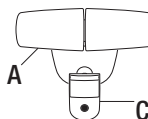

Eave Mount

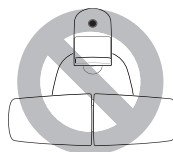
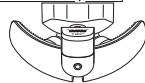

2 Removing the mounting plate



NOTE: This fixture comes with a mounting plate (D). It is pre-assembled on the light fixture (B) for shipping.



NOTE: The small mounting bolt (EE) is pre-installed in the light fixture (B). Do not attempt to remove the small mounting bolt (EE).

- Unscrew the small mounting bolt (EE) connecting the light fixture (B) to the mounting plate (D) and remove the mounting plate (D).

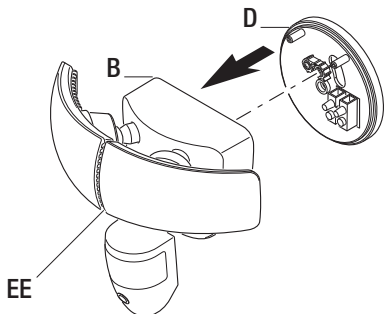

3 Installing the mounting bracket



WARNING: Turn the power off at the circuit breaker or fuse. Place tape over the circuit breaker switch and verify power is off at the light fixture.



NOTE: Six mounting bracket screws of various sizes are included. The installation will only require two. Discard the unused mounting bracket screws after installation.

- Remove the existing light fixture.
- Install the mounting bracket (FF) with the stamped word “FRONT” facing away from the junction box. Use the mounting bracket screws (BB or CC) that best fit the junction box.
- Firmly pull on the mounting bracket to verify it is securely mounted to the junction box. If necessary, use the screws that were removed from the existing light fixture.

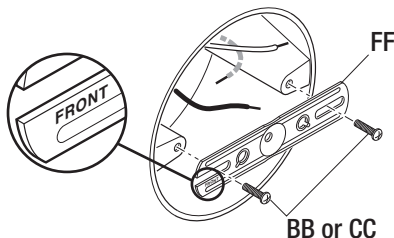

Installation (continued)

4 Installing the mounting plate

- Route the junction box wires through the hole in the mounting plate (D).
- Place the mounting plate (D) against the junction box.
 - When mounting to a wall, the “UP” arrow must point upward.
 - When mounting to an eave, the “UP” arrow must point toward the building.
- Insert the large mounting bolt (DD) through the mounting plate (D) hole located below the threaded hole, and thread it into the center hole of the mounting bracket (FF). Tighten the bolt (DD) securely.
- Firmly pull on the mounting plate (D) to verify it is securely attached to the mounting bracket (FF).

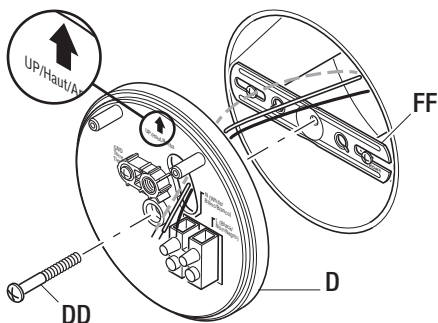

5 Making the electrical connections

- Insert the junction box wires into the side of the terminal block and around the ground screw. Tighten terminal block screws using the mini-screwdriver (GG) and ground screw to secure the wires.
- Insert the white wire from the junction box into the terminal marked “N (White)”.
- Insert the black wire from the junction box into the terminal marked “L (Black)”.
- Connect the bare or green ground wire from the junction box to the ground screw (marked with “GND”).

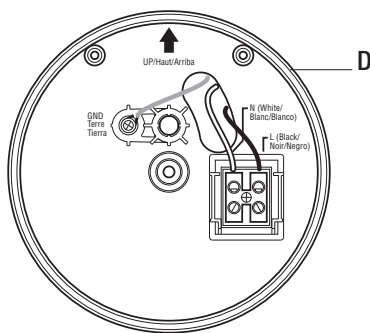

6 Mounting the light fixture

NOTICE: The two pins on the rear of the light fixture must be inserted into the terminal block for the light to work.

- Align the bottom edge of the light fixture (B) with the bottom edge of the mounting plate (D). Tilt the light fixture (B) toward the mounting plate (D), making sure the light fixture (B) is centered on the mounting plate (D).
- Tighten the small mounting bolt (EE) securely through the center of the mounting plate (D). Do not overtighten.
- Push the rubber plug (AA) firmly into the mounting bolt hole on the light fixture (B).

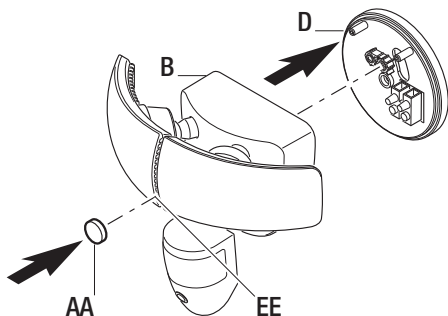

Installation (continued)

7 Caulking around the light fixture

- Caulk around the mounting plate (D) and mounting surface with silicone sealant (not included).

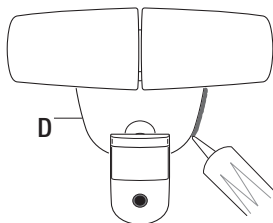

Operation

1 Adjusting the lamp heads



WARNING: Risk of fire. Keep the lamp heads at least 2 in. (51 mm) from combustible materials.



CAUTION: Keep lamp heads 30° below horizontal to avoid water damage and electrical shock.

- Turn the power on at the circuit breaker or fuse and turn on the wall switch.
- If needed, gently grasp the lamp heads (A) and tilt them up or down or side to side to adjust the light coverage area.

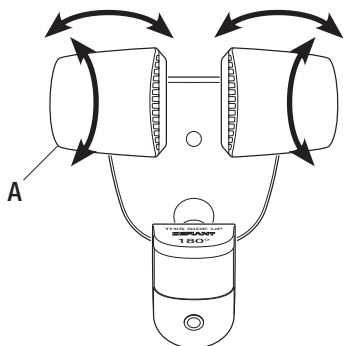

2 Rotating the sensor controls downward

- Rotate the motion sensor (C) so the text faces upward.

NOTICE: All clearances must be maintained. See *Safety Information* on page 2.

NOTICE: The Notifi™ mobile app must be downloaded to operate the light fixture. See Step 3 on page 9 for instructions.

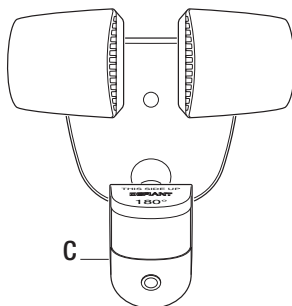



Operation (continued)

3 Downloading the mobile app

- Download the Notifi™ mobile app. Search for the “Notifi Video Solutions” app.
- iOS Devices – Download the app from the App StoreSM.
- Android Devices – Download the app from the Google Play™ store.

5 Viewing live video

The Notifi app provides live-stream video from the camera to a mobile device.

- Tap the name of the camera to be viewed.
- While in the live-stream screen, the following options are available:
 - Tap the video camera icon () to start recording live video. Tap again to stop recording.
 - Tap the camera icon () to save a still image from the live-stream video.
- To return to the main app screen, tap the () or “Back” button in the top left corner.



NOTE: All videos and images will be saved to the mobile device currently being used to view the live-stream video.

4 Connecting the light to the mobile app

NOTICE: The network password will be required to complete this process.

- Ensure the power to the light is turned ON. Allow 60 seconds for system boot-up.
- On the mobile device, go to *Settings > Wi-Fi* and select “Notifi_Video_SecurityXXXX” (“XXXX” represents the unique MAC address of each light fixture) from the available Wi-Fi networks.
- Once connected, open the Notifi app. The app will detect the new light.
- Select “Yes” to start the setup and the app will guide you through the remaining steps.



NOTE: When creating a new Notifi account, the username and password must be a minimum of 4 characters and a maximum of 12 characters. Alpha-numeric and/or special characters may be used.

6 Understanding the motion detection process

This light has dual motion detection technologies.

- The light is controlled by a 180° PIR (passive infra-red) sensor. This sensor detects a temperature difference moving in front of it. When motion is detected after dark, the light will come on at the selected “Full Bright Intensity” level.
- The camera uses both the 180° PIR sensor as well as a 100° image sensor located within the camera software. The camera’s image sensor will not activate unless the PIR sensor first detects a moving temperature difference within the detection zone. The camera will record motion day or night.

7 Using the event list

Tap the Events tab.

An event is created each time the camera senses motion.

- Basic Service – The event list will show the date and time the motion was detected.
- Premium Service (available for an additional fee) – The event list will include the date, time, and video of the event each time motion was detected. The video of each event will also be available to download for 30 days.

9 Adjusting the light settings

The light settings allow you to adjust the full bright duration, the DualBrite® duration, and the percentages of light intensity.



NOTE: Changes made to one light's settings will not affect another light's settings.

Tap > Feature Settings > Light to select the light settings.

- Full Bright Duration – This adjusts the amount of time the light will stay ON after all motion has stopped.
- DualBrite Duration – This adjusts the amount of time the light stays ON at a reduced brightness level when no motion is detected.
- Full Bright Intensity – This adjusts the intensity level of the light when motion is detected.
- DualBrite Dimming Level – This adjusts the intensity level of the light when no motion is detected.

8 Receiving notifications

Tap > Feature Settings > Notifications to select the notification settings.

If notifications are turned on, an email and/or push notification is sent each time the camera senses motion. Tap on the notification to be taken to the live-view video screen (Basic service) or the Event video (Premium service).

10 Adjusting the camera settings

The camera settings allow you to adjust the motion detection sensitivity, motion detection zones, and video quality.



NOTE: Changes made to one camera's settings will not affect another camera's settings.



NOTE: The higher the "Sensitivity" setting, the greater the possibility of false triggering. To reduce false triggering, select a lower setting.

Tap > Feature Settings > Camera to select the camera settings.

- Motion Detection – This adjusts the camera's sensitivity to motion in its field of view.
- Motion Detection Zones – This adjusts the camera's detection area to include or exclude zones in its field of view.
- Auto Adjust – Disabling this setting allows manual adjustments of the video's quality settings. For best performance, leave the Auto Adjust ON.

11 Setting the sensor for testing



NOTE: The light fixture will operate during the day or night during testing. The light will stay on for 5 seconds after all motion is stopped.



NOTE: The light requires a 60-second boot-up period before the camera will be fully operational.

Tap  > Feature Settings > Camera > Motion Detection to select the motion detection settings.

The light fixture will automatically enter “Test” mode whenever the “Motion Detection” option is selected. The light fixture will remain in “Test” until one of the following actions occurs:

- The “Save” or “Cancel” option is selected.
- No movement during the testing process for 30 seconds.
- Three minutes have passed without changing one of the on-screen settings.

12 Adjusting the motion sensor detection zone



NOTE: The camera's (E) detection zone is inside of the light's detection zone. When the motion sensor (C) for the light is adjusted, the camera's (E) motion sensor will also be adjusted.

If motion is detected outside the camera's detection zone, the light may turn on but the camera will not record an event.

- Perform a “walk test”: walk in an arc across the front of the motion sensor (C).
- Watch the light. The light will come on and the red LED will flash indicating motion has been detected.
- Stop, wait for the light to turn off, and then begin walking again.
- Continue this process until the detection zone has been established.
- If needed, gently grasp the motion sensor (C) and move it from side to side or up and down to adjust the detection zone.
- Adjust the “Motion Detection” sensitivity to High, Medium, or Low as needed.



NOTE: The motion sensor (C) is more sensitive to motion moving across the front of the sensor. The motion sensor (C) is less sensitive to motion moving directly toward the front of the sensor.

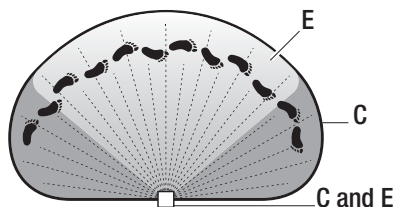

Operation (continued)

13 Adding multiple users

The Notifi system allows control of multiple users within an account.

Tap  > Advanced Settings > Manage Multiple Users.

- Tap the “Add Viewers” button and type the email address in the “To:” field.
- Tap the “Send” button.



NOTE: When adding multiple users, separate the email addresses with a semicolon.

14 Adding system name and photo

Add a name and photo to represent the Notifi system on the mobile device. The photo will be placed inside the blue circle icon next to the selected Notifi system.

Tap  > Advanced Settings > System Name/Photo.

- Enter a name for the Notifi system.
- Select an existing photo and take a new photo to represent the Notifi system.



NOTE: The light settings and name are stored in the light fixture. The photo is locally stored on the mobile device and is only visible on that device.

15 Using manual mode

Manual mode overrides the motion sensor (C) and will turn the light on at the preset “Full Bright Intensity” level. This feature works day or night. The motion sensor (C) will reset to motion sensing mode at sunrise.

- On the main screen under the “Systems” tab, choose “ON”, “OFF”, or “AUTO” to control the lights for the selected Notifi system.

16 Deleting a Notifi system

To delete a Notifi system from an account:

- Turn off the wall switch controlling the Notifi system.
- On the main “Systems” screen, wait for the system to go offline (the system name and image will turn gray).
- Once offline, swipe the Notifi system to be deleted to the left and tap the trashcan icon ().

Care and Cleaning

- To prolong the original appearance, clean the light fixture with clear water and a soft, damp cloth only.
- Do not use paints, solvents, or other chemicals on this light fixture. They could cause a premature deterioration of the finish. This is not a defect in the finish and will not be covered by the warranty.
- Do not spray the light fixture with a hose or power washer.
- To clean the camera lens, use a dry, microfiber cloth only.

Troubleshooting

Problem	Possible Cause	Solution
The light will not come on.	<ul style="list-style-type: none"> □ The light switch is turned off. □ The fuse is blown or the circuit breaker is turned off. □ The light is not scheduled to come ON. □ The circuit wiring is incorrect (if this is a new installation). □ The motion sensor is aimed in the wrong direction. □ The outside air temperature is close to the same as a person's body heat. 	<ul style="list-style-type: none"> □ Turn the light switch on. □ Replace the fuse or turn the circuit breaker on. □ Recheck the light operation during the scheduled "DualBrite Duration" (after sunset). □ Verify the wiring is correct. □ Re-aim the motion sensor to cover the desired area. □ Increase the "Motion Detection" setting.
The light comes on during the day.	<ul style="list-style-type: none"> □ The light is scheduled to come ON. 	<ul style="list-style-type: none"> □ Adjust the scheduled light operation in "DualBrite Duration."
The light comes on for no apparent reason.	<ul style="list-style-type: none"> □ The motion sensor may be sensing small animals or automobile traffic. □ The "Motion Detection" setting is set too high. □ The "DualBrite Duration" is operating at the preset "DualBrite Dimming Level" setting. □ The outside temperature is much warmer or cooler than a person's body heat (summer or winter). □ The light fixture is wired through a dimmer or timer. 	<ul style="list-style-type: none"> □ Decrease the "Motion Detection" setting or reposition the motion sensor. □ Decrease the "Motion Detection" setting. □ The light fixture is operating normally under these circumstances. The "DualBrite Duration" time is adjustable. □ Decrease the "Motion Detection" setting. □ Do not use a dimmer or timer to control the light fixture. Replace the dimmer or timer with a standard on/off wall switch.
The lights stay ON too late in the "DualBrite Duration" setting.	<ul style="list-style-type: none"> □ The "DualBrite Duration" OFF time is set to late. 	<ul style="list-style-type: none"> □ Adjust the "DualBrite Duration" OFF time to the desired setting.
The lights do not stay ON late enough in the "DualBrite Duration" setting.	<ul style="list-style-type: none"> □ The "DualBrite Duration" OFF time is set to early. 	<ul style="list-style-type: none"> □ Adjust the "DualBrite Duration" OFF time to the desired setting.

Troubleshooting (continued)

Problem	Possible Cause	Solution
The lights stay on continuously.	<ul style="list-style-type: none"> □ The motion sensor may be picking up a heat source, such as an air vent, dryer vent, or brightly painted, heat-reflective surface. □ The motion sensor is in manual mode. □ The light fixture is wired through a dimmer or timer. □ The light fixture is on the same circuit as a motor, transformer, or fluorescent bulb. 	<ul style="list-style-type: none"> □ Decrease the “Motion Detection” setting or reposition the motion sensor. □ Turn the manual mode option to Off or Auto. See <i>Using manual mode</i> on page 12. □ Do not use a dimmer or timer to control the light fixture. Replace the dimmer or timer with a standard on/off wall switch. □ Install the light fixture on a circuit without motors, transformers, or fluorescent bulbs.
The lights flash on and off.	<ul style="list-style-type: none"> □ Heat or light from the lamp heads may be turning the motion sensor on and off. □ Heat is being reflected from other objects and may be turning the motion sensor on and off. 	<ul style="list-style-type: none"> □ Reposition the lamp heads away from the motion sensor. □ Decrease the “Motion Detection” setting or reposition the motion sensor.
The light fixture is not responding to the app.	<ul style="list-style-type: none"> □ The light is offline (the system name and image are gray). □ The light is unable to connect to the wi-fi (the system name and image are gray). 	<ul style="list-style-type: none"> □ Ensure the light has power. □ Ensure the light is connected to the wi-fi router. □ Turn the power to the light off. Wait 30 seconds and turn the power on. Wait 60 seconds for the light to boot-up.
The app is not finding the light fixture.	<ul style="list-style-type: none"> □ The light may have been deleted from the account. 	<ul style="list-style-type: none"> □ Reconnect the light to the app (see step 4, page 9).
Motion notifications are not being sent to the app.	<ul style="list-style-type: none"> □ Notifications are turned off in the app. □ Motion is not being detected inside the camera’s detection zone. 	<ul style="list-style-type: none"> □ Turn notifications on in the app (see step 8, page 10). □ Re-aim the motion sensor to cover the desired area or increase the “Motion Detection” setting.

DEFIANT®

**Questions, problems, missing parts?
Before returning to the store, call Defiant Customer Service
8 a.m.-7 p.m., EST, Monday-Friday, 9 a.m. - 6 p.m., EST, Saturday**

1-866-308-3976

HOMEDEPOT.COM

Retain this manual for future use.

Apple and the Apple logos are trademarks of Apple Inc., registered in the U.S., and other countries. App Store is a service mark of Apple Inc.

Google Play is a trademark of Google Inc.

Android is a trademark of Google Inc.

Wi-Fi® is a registered trademark of Wi-Fi Alliance