



Item #000000000  
Model #HB-7901-02

# USE AND CARE GUIDE

---

## WIRELESS DOORBELL AND MAIL REMINDER KIT

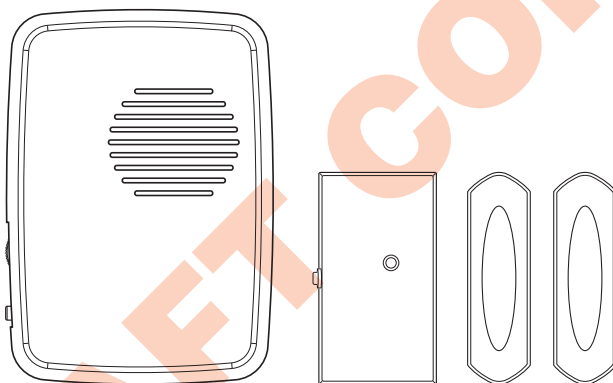

Questions, problems, missing parts?  
Before returning to the store, call Hampton Bay Customer Service  
8 a.m. - 5 p.m., CST, Monday - Friday

1-844-760-3644

HAMPTONBAY.COM

Illustrations may vary from actual unit.

---

### THANK YOU

*We appreciate the trust and confidence you have placed in Hampton Bay through the purchase of this wireless doorbell and mail reminder kit. We strive to continually create quality products designed to enhance your home. Visit us online to see our full line of products available for your home improvement needs. Thank you for choosing Hampton Bay!*

# Table of Contents

Table of Contents .....	2	Tools Required .....	3
Safety Information .....	2	Hardware Included .....	3
Warranty .....	2	Package Contents .....	4
3-Year Limited Warranty .....	2	Installation .....	4
Pre-Installation .....	3	Operation .....	6
Planning Installation .....	3	Care and Cleaning .....	7
Specifications .....	3	Troubleshooting .....	7

# Safety Information

## PRECAUTIONS

- Please read and understand this entire manual before attempting to assemble, install, or operate this doorbell.
- All electrical work must be in accordance with national and local electrical codes. If in doubt, consult a qualified electrician.

 **NOTE:** The mailbox sensor, push buttons, and doorbell come synced from the factory. The range of the wireless doorbell can vary with location, temperature, and battery condition.

This device complies with Part 15 of the FCC Rules and RSS-210 of Industry Canada. Operation is subject to the following two conditions: (1) this device may not cause harmful interference, and (2) this device must accept any interference received, including interference that may cause undesired operation.

The user is cautioned that changes or modifications not expressly approved by the party responsible for regulatory compliance could void the user's authority to operate the equipment.

 **WARNING:** To prevent possible **SERIOUS INJURY** or **DEATH** never allow small children near batteries. If battery is swallowed, immediately notify a doctor.

 **WARNING:** Risk of fire. Do not plug the doorbell into a power inverter.

# Warranty

## 3-YEAR LIMITED WARRANTY

### WHAT IS COVERED

This product is guaranteed to be free of factory defective parts and workmanship for a period of 3 years from date of purchase. Purchase receipt is required for all warranty claims.

### WHAT IS NOT COVERED

This warranty does not include expendable items (such as light bulbs, batteries, etc.), repair service, adjustment and calibration due to misuse, abuse or negligence. Unauthorized service or modification of the product or of any furnished component will void this warranty in its entirety. This warranty does not include reimbursement for inconvenience, installation, setup time, loss of use, unauthorized service, or return shipping charges. This warranty is not extended to other equipment and components that a customer uses in conjunction with this product.

Contact the Customer Service Team at 1-844-760-3644 or visit [www.hamptonbay.com](http://www.hamptonbay.com).

# Pre-Installation

## PLANNING INSTALLATION

Before installing the wireless doorbell and mail reminder kit, ensure that all parts are present. Compare parts with the *Hardware Included* and *Package Contents* sections. If any part is missing or damaged, do not attempt to assemble, install, or operate this wireless doorbell and mail reminder kit.

Estimated installation time: 30 minutes

The mailbox sensor will only work on mailboxes that have a vertical, tilt-style door. Mailboxes with doors that open horizontally (side-to-side) will not work with this sensor.

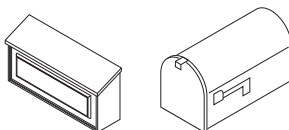

## SPECIFICATIONS

	Doorbell	Push buttons	Mailbox sensor
Power requirements	120 V, 60 Hz	Type A23 12V battery (included)	Type 2032 3V battery (included)

## TOOLS REQUIRED



Phillips screwdriver



Small flathead screwdriver

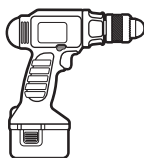

Drill



1/16"  
(1.5 mm)  
Drill bit



Safety goggles

## HARDWARE INCLUDED



NOTE: Hardware shown to actual size.



AA



BB

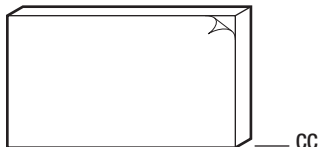

CC

Part	Description	Quantity
AA	Jumper	1
BB	Screw	4
CC	Double-sided tape	3

# Pre-Installation (continued)

## PACKAGE CONTENTS

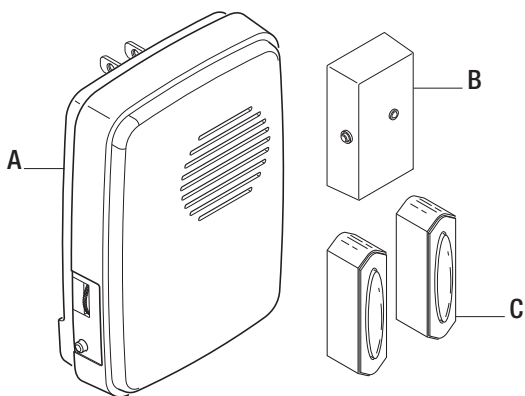

Part	Description	Quantity
A	Doorbell	1
B	Mailbox sensor	1
C	Push button	2

## Installation

### 1 Installing the doorbell

- Plug in the doorbell (A) at the desired location.

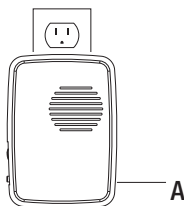

### 2 Removing the battery tab

- Remove the backs of the sensor (B) and push buttons (C) by pushing in the tab on the bottom with a small screwdriver (not included).
- Remove the orange battery tab from the sensor (B) and push buttons (C).

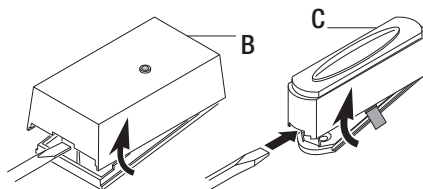

## Installation (continued)

### 3 Testing the push button and doorbell

- Temporarily position the push button (C) where it will be mounted.
- Press the push button (C) to verify the doorbell (A) and push button (C) work properly.
- If the doorbell (A) does not sound, move the doorbell (A) closer to the push button (C) and test again.

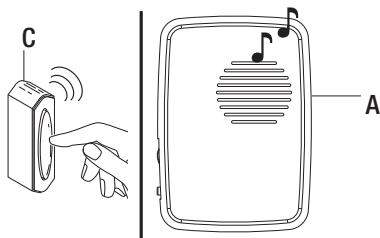

**NOTE:** Do not permanently mount the sensor or push buttons until the sensor, push buttons, and doorbell are all working properly.

### 4 Testing the sensor and doorbell

In most cases, testing of the mailbox sensor requires two people; one person to take the sensor (B) to the mailbox for testing and the other to listen for the doorbell and watch for the “envelope” icon on the doorbell to light up.

- Temporarily position the sensor (B) next to the mailbox.
- While someone is watching and listening for the doorbell (A), hold the sensor (B) as shown and rotate to the horizontal position. The red LED on the sensor (B) should flash, the doorbell (A) will sound “Beep-Beep”, and the “envelope” icon will turn ON.
- To reset the “envelope” icon to the OFF position, either press and release the button on the side of the sensor (B) or quickly press and release the button on the side of the doorbell (A) twice.



**NOTE:** If the button on the side of the sensor is pressed to reset the “envelope” icon, there is a 10 second delay before the sensor will be able to re-activate the chime.



**NOTE:** Do not permanently mount the sensor or push buttons until the sensor, push buttons, and doorbell are all working properly.

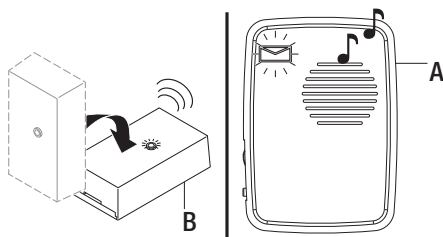

### 5 Mounting the push button

Use either screws (BB) or double-sided tape (CC) to mount the push button (C).

- To mount with screws (BB), remove the back of the push button (C) by pushing in the tab on the bottom with a small screwdriver. Place the push button back on the door jamb and mark the two screw holes. Attach with screws (BB) and snap on the front of the push button (C).
- When attaching the push button (C) with double-sided tape (CC), remove paper from both sides of the double-sided tape (CC) and apply to a clean surface.

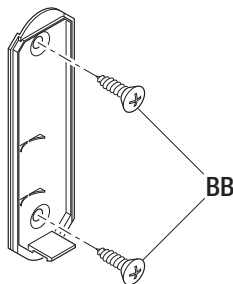

## Installation (continued)

### 6 Mounting the sensor in a wall mounted mailbox

Use double-sided tape (CC) to mount the sensor (B). Remove paper from both sides of the double-sided tape (CC) and apply to a clean surface.

- Open the lid of the mailbox.
- Hold the sensor (B) with the screwdriver slot pointing upward and the side button on the right side of the sensor (B).
- Apply the double-sided tape (CC) to the back of the sensor (B) and mount on the inside of the mailbox lid.

 **NOTE:** When installed correctly, the red LED on the sensor will flash when the mailbox lid is opened.

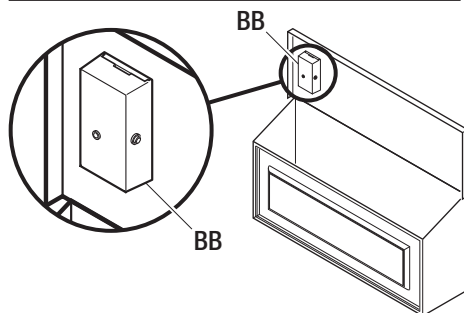

### 7 Mounting the sensor in a post mounted mailbox

Use double-sided tape (CC) to mount the sensor (B). Remove paper from both sides of the double-sided tape (CC) and apply to a clean surface.

- Open the door of the mailbox.
- Hold the sensor (B) with the screwdriver slot pointing upward and the side button on the right side of the sensor (B).
- Apply the double-sided tape (CC) to the back of the sensor (B) and mount on the inside of the mailbox lid.

 **NOTE:** When installed correctly, the red LED on the sensor will flash when the mailbox door is opened.

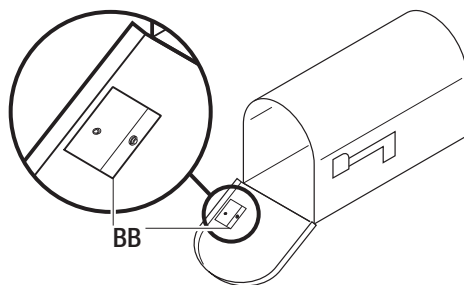

## Operation

### 1 Adjusting the doorbell volume

The doorbell (A) has an adjustable volume control located on the side. Rotate the thumbwheel up or down to adjust the volume.

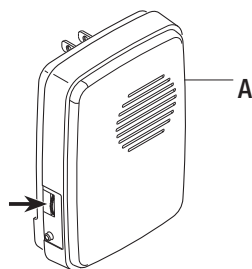

## Operation (continued)

### 2 Setting the wireless push button



**NOTE:** The two push buttons included in this kit will come factory set for front and back doors. A decal on the rear of the push button will indicate its setting.

The wireless push button (C) has two options for tune selection: Play the selected "FRONT" door musical tune or play the "REAR" door designated tune (Ding).

- ❑ Remove the single jumper inside the push button (C) to play the selected musical tune.
- ❑ Add the single jumper inside the push button (C) to play only the Ding tune.

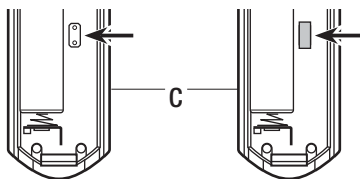

Remove jumper to set as the "FRONT" door

Add jumper to set as the "REAR" door

### 3 Selecting a push button tune

The doorbell (A) has different selectable tunes for push buttons (C). The push button (C) set as the "REAR" push button (C) will only play Ding (one note tune). The push button (C) set as the "FRONT" push button (C) will either Ding-Dong (two note tune) or Westminster (eight note tune).

- ❑ Press and release the "TUNE" button on the doorbell (A) until desired tune is heard.



**NOTE:** All doorbell models are designed to work with up to 10 wireless push buttons (sold separately).



**NOTE:** All doorbells are designed to play only two different tunes no matter how many push buttons are used.

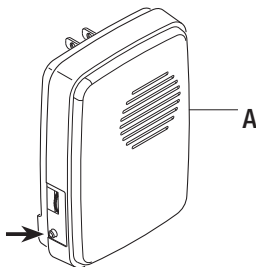

	Mailbox alert	Front door push button (sold separately)	Rear door push button (sold separately)
Doorbell tune	Beep-Beep	Ding-Dong or Westminster	Ding

### 4 Using the sensor

The sensor (B) will activate the doorbell (A) each time the mailbox is opened. The doorbell (A) will sound a "Beep-Beep" tone and the "envelope" icon will glow. The "envelope" icon will continue to glow until one of the following steps is done:

- ❑ Press and release the button on the side of the sensor (B) or...
- ❑ Quickly press and release the button on the side of the doorbell (A) twice.



**NOTE:** If the button on the side of the sensor is pressed to reset the "envelope" icon, there is a 10 second delay before the sensor will be able to re-activate the chime. This delay will ensure that the mailbox is closed before the sensor will be able to activate the doorbell again.

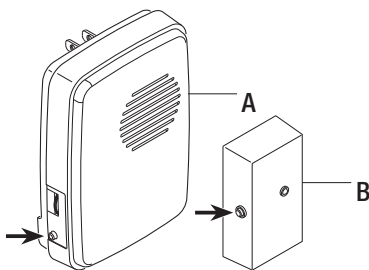

## Care and Cleaning

- Use a dry cloth to clean the doorbell, sensor, and push buttons.
- Do not use cleaners or polishes.
- Do not use any fluids on the doorbell, sensor, and push buttons.

## Troubleshooting

Problem	Possible Cause	Solution
Doorbell does not sound.	<ul style="list-style-type: none"><li>□ Batteries not installed correctly.</li><li>□ Batteries are dead.</li><li>□ Doorbell is not receiving power.</li><li>□ The doorbell and the sensor or push buttons are not synced.</li></ul>	<ul style="list-style-type: none"><li>□ Make sure batteries are installed according to the diagram inside the sensor and push buttons.</li><li>□ Check the charge of the sensor and push button batteries and replace if necessary.</li><li>□ Make sure the plug-in doorbell has power.</li><li>□ Sync the doorbell to the sensor or push button(s). Only one sensor or push button may be synced at a time. Repeat these steps for each sensor or push button.<ul style="list-style-type: none"><li>□ Press and hold the button on the doorbell until the doorbell sounds a “Beep-Beep”.</li><li>□ Press the button on the side of the sensor or the push button(s) within 30 seconds. The doorbell will sound a “Beep-Beep” tone to indicate the sensor or the push button(s) is synced.</li><li>□ Rotate the sensor as shown in step 4 under Installation or press the push button(s) to ensure operation.</li></ul></li></ul>



## Troubleshooting (continued)

Problem	Possible Cause	Solution
Batteries seem okay, but the doorbell does not work after installation.	<ul style="list-style-type: none"> <li>□ Doorbell or push button(s) is mounted on metal or near metal studs.</li> <li>□ Doorbell is mounted near concrete floor or wall.</li> <li>□ Doorbell and sensor or push button(s) are installed too far apart.</li> </ul>	<ul style="list-style-type: none"> <li>□ Metal reduces transmission range. Use 1/4 in. to 1/2 in. (6 to 13 mm) wood shims to move the doorbell or push button(s) away from the metal surface.</li> <li>□ Concrete may reduce range. Move the doorbell away from the concrete surface.</li> <li>□ Locate the doorbell closer to the sensor or push button(s).</li> </ul>
The “envelope” icon glows continually.	<ul style="list-style-type: none"> <li>□ Reset the “envelope” icon.</li> </ul>	<ul style="list-style-type: none"> <li>□ To reset the icon, press and release the button on the side of the sensor or quickly press and release the button on the side of the doorbell twice.</li> </ul>
Doorbell sounds when not intended (false triggers).	<ul style="list-style-type: none"> <li>□ Doorbell is receiving interference from another wireless device.</li> </ul>	<ul style="list-style-type: none"> <li>□ Reset the doorbell, sensor, and push buttons.               <ul style="list-style-type: none"> <li>□ Remove the sensor and push button batteries. Wait 30 seconds.</li> <li>□ Press and hold the push buttons and the button on the side of the sensor for 10 to 15 seconds within 60 seconds after installing batteries into the push buttons and sensor.</li> <li>□ Press and hold the button on the doorbell until the doorbell sounds a “Beep-Beep-Beep-Beep”.</li> </ul> </li> <li>□ Re-sync the doorbell to the sensor and push buttons. Only one sensor or push button may be synced at a time. Repeat these steps for each sensor or push button.               <ul style="list-style-type: none"> <li>□ Press and hold the button on the doorbell until the doorbell sounds a “Beep-Beep”.</li> <li>□ Press the button on the side of the sensor or the push button within 30 seconds. The doorbell will sound a “Beep-Beep” tone to indicate the sensor or the push button is synced.</li> <li>□ Rotate the sensor as shown in step 4 under Installation or press the push button(s) to ensure operation.</li> </ul> </li> </ul>



**Questions, problems, missing parts?  
Before returning to the store, call Hampton Bay Customer Service  
8 a.m. - 5 p.m., CST, Monday - Friday**

**1-844-760-3644**

**HAMPTONBAY.COM**

**Retain this manual for future use.**