

- * BEFORE YOU START
- * Always Wear Safety Glasses!
- * Use Extra Caution when Working With Electrical Components

Wireless Mini Digital Shift Light & Diagnostic Tachometer

Part no: 67006

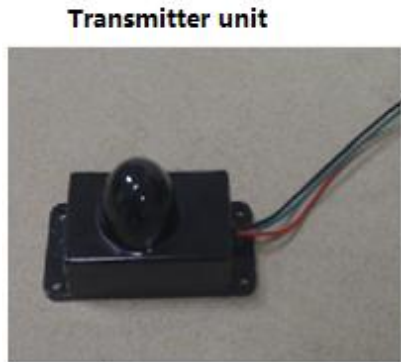
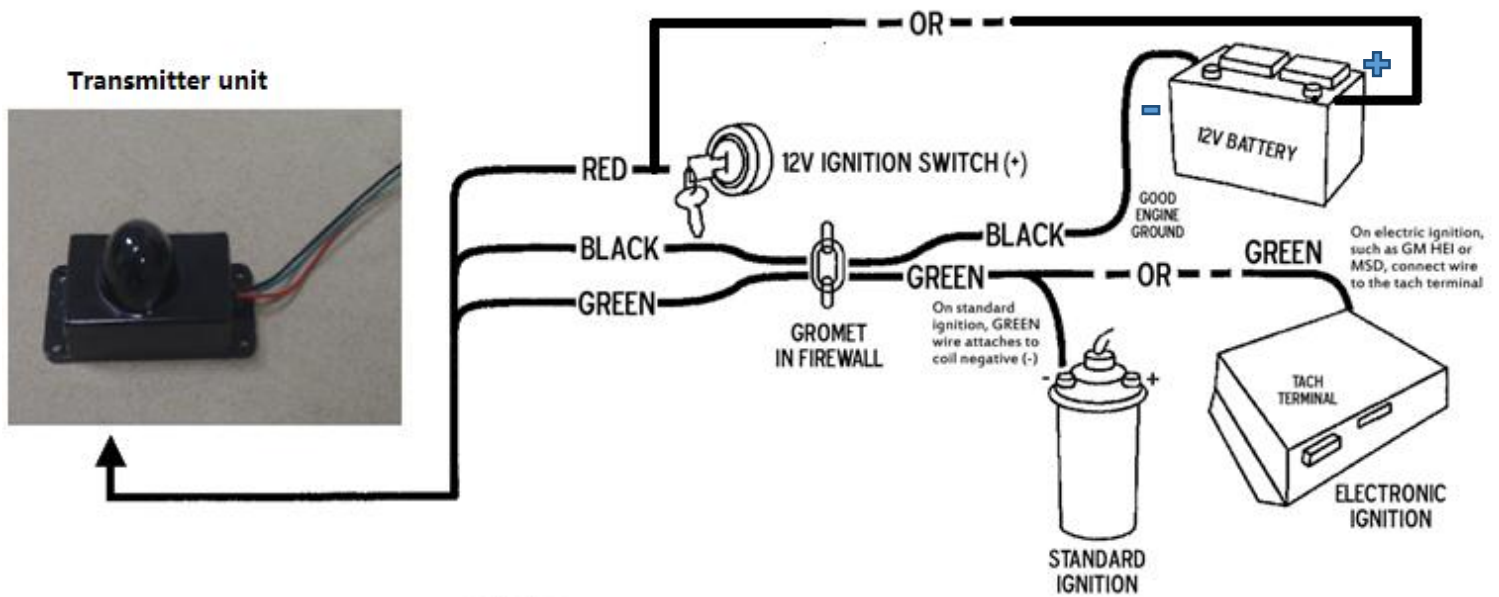

Receiver display unit



----- Mounting -----

The transmitter unit is designed to be installed inside the engine compartment and tied securely using nylon zip tie. The versatile shift light receiver display base design permits many mounting possibilities, using ordinary machine screws. In some cases mounting with a hose clamp, or a basic 2 sided adhesive may be preferred. The mounting base connects into three different positions on the shift light, which allows the light to be adjusted forward or backward depending on external clearance issues that may be present. To remove the mounting base, simply slide it toward the rear of the shift light.

----- Troubleshooting -----

Proper shift light operation requires a good ground and securely connected wiring. If you are having trouble, double---check your ground and be certain that you have 12 volt power. Be sure you have followed the wiring diagram instructions above. We recommend you avoid crimp connectors and solder all connections if possible. Soldering your connections will minimize any loose connections that may cause problems.



Wireless Mini Digital Shift Light & Diagnostic Tachometer Operating Instructions (part no. 67006)

Product Overview:

The wireless Mini Shift Light & Diagnostic Tachometer is designed for regular use as a shift light, and tachometer use when working under the hood. The tachometer functionality is not intended for use when driving the vehicle.

The main features include:

- Shift light with 3 bright amber colored LED lights
- 1 thru 12 cylinder functionality
- 100---12,000 RPM range
- Adjustable display brightness
- Display on/off mode

The transmitter unit easy---to---connect 3 wire hook up is intended to make installation fast and easy for most engines. Please note that some late model vehicles that do not use ignition distributors may need a tach adapter (not included).

Installation:

1. Install the transmitter unit and connect the wires as depicted in the wiring diagram on separate page.
2. Use zip ties or tape to wrap the wires in an organized way before operating.
3. Mount the receiver shift light display unit with screws, adhesive, or hose clamps to a desirable location within the cockpit of the vehicle so the lighted end is within the driver's forward line of sight. Please note: it may be easier to install if the light is disconnected from the mounting base.

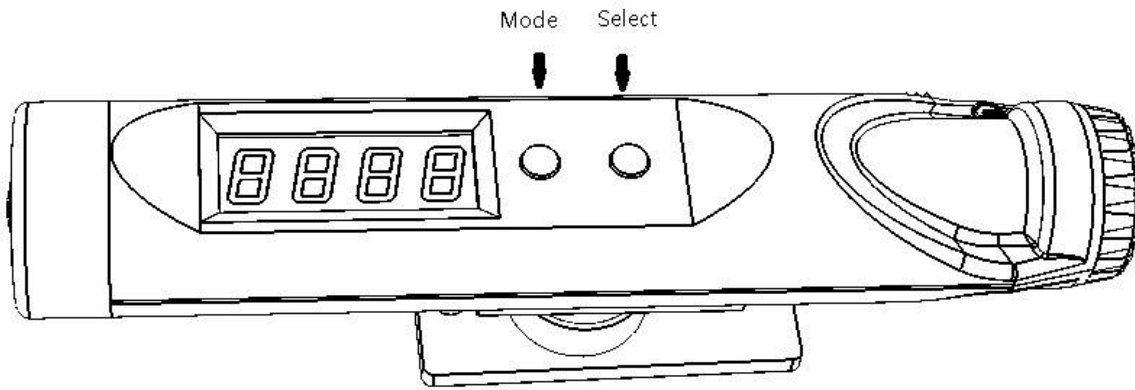

Operation:

1. Turn the circular battery cover off and insert 4 pieces of LR44(303) or SR44(357) batteries into the cavity, be careful of the orientation of the battery must be the same as the indication on the case.
2. Switch on the small on/off switch at the rear part of the device. The display should show '---' if the transmitter unit is not power up. It should show '0' if it is only power up and the engine is not running.
3. Setting the number of **Cylinders**
 - a. Press and release the **Mode** button until the display reads **CY**.
 - b. Press and release the **Set** button until the correct number of cylinders is shown next to CY.
 - c. Press and release the **Mode** button once to set the number of cylinders
4. Setting the **RPM** shift point
 - a. Press and release the **Mode** button until the display reads **A**.
 - b. Press and release the **Set** button to set the RPM shift point (Units are x100 RPM's, e.g. 52 = 5,200 RPM's).
 - c. Press and release the **Mode** button once to set the RPM value.
5. Setting the display **Intensity**
 - a. Press and release the **Mode** button until the display reads **I**.
 - b. Press and release the **Set** button for brightness values that range from 0---7.
 - c. Press and release the **Mode** button once to set the display intensity.
6. Setting the display **On/Off** when in use
 - a. Press and release the **Mode** button until the display reads **IED**.
 - b. Press and release the **Set** button to 0, 1, or 2. Select 0 or 2 to turn the RPM display off when in use. Select 1 for the RPM display to be on at all times.
 - c. Press and release the **Mode** button once to set the On/Off.

Once the initial setup is complete the RPM values will be shown on the display when the vehicle is running. The shift light will remain on when the shift point is exceeded, and turn off when the RPM's fall below that point.

For addition tech support related to this genuine PROFORM product, please call (586)774---2500, Monday---Friday, 9 a.m.---5 p.m. EST, or send an email to tech@ProformParts.com

© 2014 Specialty Auto Parts U.S.A., Inc. All rights reserved

This device complies with Part 15 of the FCC Rules. Operation is subject to the following two conditions: (1) this device may not cause harmful interference, and (2) this device must accept any interference received, including interference that may cause undesired operation.

The statements should be displayed in the user manual:

changes or modifications not expressly approved by the party responsible for compliance could void the user's authority to operate the equipment.

This equipment has been tested and found to comply with the limits for a Class B digital device, pursuant to Part 15 of the FCC Rules. These limits are designed to provide reasonable protection against harmful interference in a residential installation. This equipment generates, uses and can radiate radio frequency energy and, if not installed and used in accordance with the instructions, may cause harmful interference to radio communications. However, there is no guarantee that interference will not occur in a particular installation.

If this equipment does cause harmful interference to radio or television reception, which can be determined by turning the equipment off and on, the user is encouraged to try to correct the interference by one or more of the following measures:

- Reorient or relocate the receiving antenna.
- Increase the separation between the equipment and receiver.
- Connect the equipment into an outlet on a circuit different from that to which the receiver is connected.
- Consult the dealer or an experienced radio/TV technician for help.