

IAP-92 and IAP-93 Wireless Access Point

Installation Guide

About the Aruba IAP-92/IAP-93

The Aruba IAP-92 and IAP-93 are single-radio, dual-band wireless access points that support the IEEE 802.11n standard for high-performance WLAN. These access points use MIMO (Multiple-in, Multiple-out) technology and other high-throughput mode techniques to deliver high-performance, 802.11n 2.4 GHz or 5 GHz functionality while simultaneously supporting existing 802.11a/b/g wireless services. The IAP-92 and IAP-93 access points work only in conjunction with an Aruba Controller.

The Aruba IAP-92/IAP-93 access point provides the following capabilities:

- Wireless transceiver
- Protocol-independent networking functionality
- IEEE 802.11a/b/g/n operation as a wireless access point
- IEEE 802.11a/b/g/n operation as a wireless air monitor
- Compatibility with IEEE 802.3af PoE
- Central management configuration and upgrades through an Aruba Controller



The Aruba IAP-92/IAP-93 requires ArubaOS 5.0.1 or later.

Package Contents

- IAP-92 or IAP-93 access point
- Installation Guide



Inform your supplier if there are any incorrect, missing, or damaged parts. If possible, retain the carton, including the original packing materials. Use these materials to repack and return the unit to the supplier if needed.

Figure 1 IAP-92/IAP-93 (IAP-92 Shown)

IAP-92/IAP-93 Hardware Overview

Figure 2 Front (IAP-92 Shown)

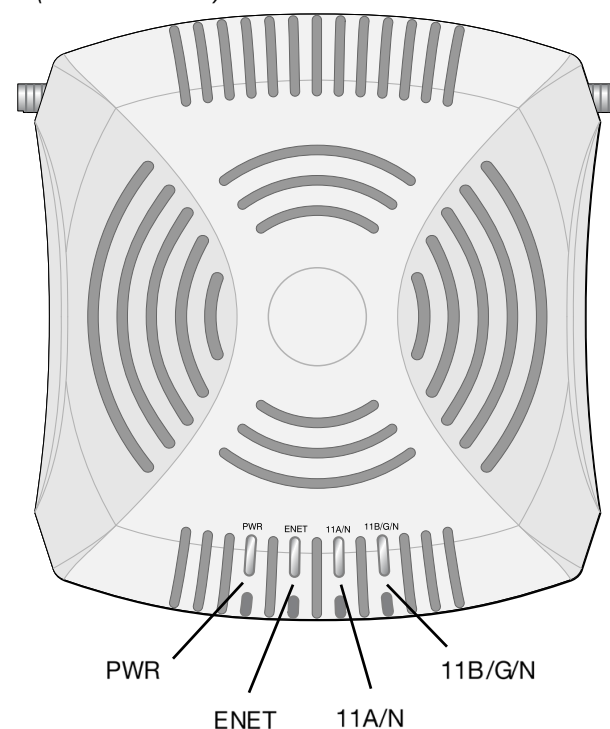

LEDs

- PWR: Indicates whether or not the IAP-92/IAP-93 is powered-on
- ENET: Indicates the status of the IAP-92/IAP-93's Ethernet port
- 11A/N: Indicates the status of the 802.11a/n radio
- 11B/G/N: Indicates the status of the 802.11b/g/n radio

For information about the IAP-92/IAP-93's LED behavior, see Table 1.

Figure 3 Rear (IAP-92 Shown)

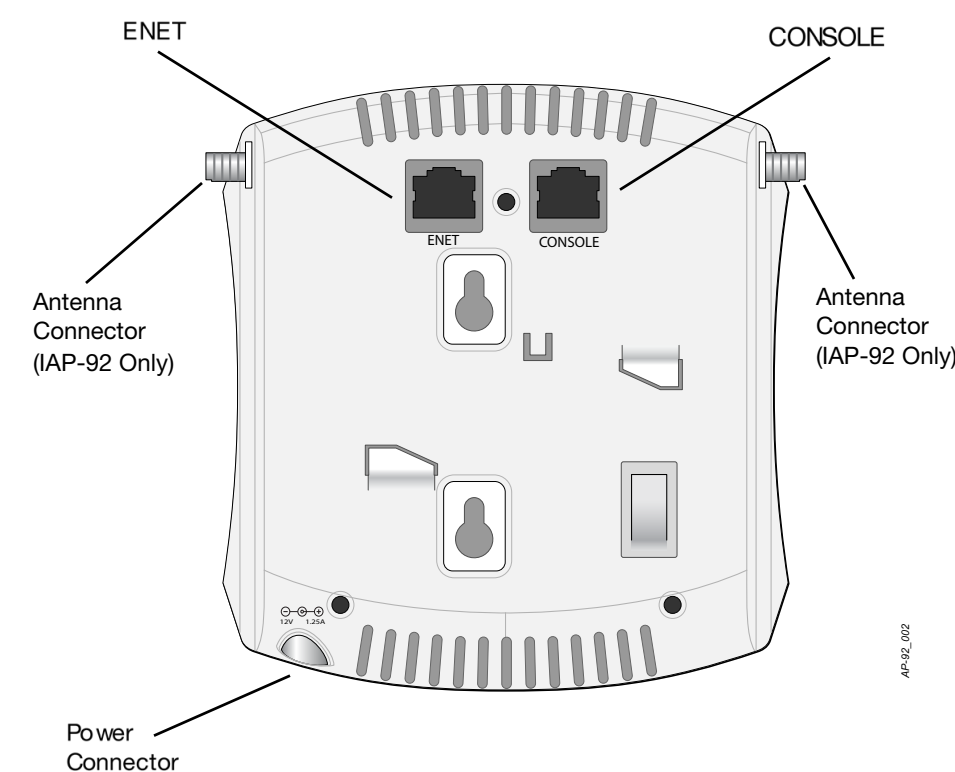

Console Port

Use the console port to connect to a terminal for direct local management.

Ethernet Port

IAP-92/IAP-93 is equipped with a single 10/100/1000Base-T (RJ-45) auto-sensing, MDI/MDX wired-network connectivity port. This port supports IEEE 802.3af Power over Ethernet (PoE) compliance, accepting 48VDC as a standard defined Powered Device (PD) from a Power Sourcing Equipment (PSE) such as a PoE midspan injector, or network infrastructure that supports PoE.

DC Power Socket

If PoE is not available, an optional Aruba AP AC-DC adapter kit (sold separately) can be used to power the IAP-92/IAP-93.

Reset Button

The reset button can be used to return the AP to factory default settings. To reset the AP:

1. Power off the AP.
2. Press and hold the reset button using a small, narrow object, such as a paperclip.
3. Power-on the AP without releasing the reset button. The power LED will flash within 5 seconds.
4. Release the reset button.

The power LED will flash again within 15 seconds indicating that the reset is completed. The AP will now continue to boot with the factory default settings.

External Antenna Connectors

The IAP-92 is designed for use with external antennas. The IAP-93 is equipped with internal antennas.

Before You Begin



FCC Statement: Improper termination of access points installed in the United States configured to non-US model controllers will be in violation of the FCC grant of equipment authorization. Any such willful or intentional violation may result in a requirement by the FCC for immediate termination of operation and may be subject to forfeiture (47 CFR 1.80).



EU Statement: Lower power radio LAN product operating in 2.4 GHz and 5 GHz bands. Please refer to the *ArubaOS User Guide* for details on restrictions.

Produit réseau local radio basse puissance opérant dans la bande fréquence 2.4 GHz et 5 GHz. Merci de vous référer au *ArubaOS User Guide* pour les détails des restrictions.

Low Power FunkLAN Produkt, das im 2.4 GHz und im 5 GHz Band arbeitet. Weitere Informationen bezüglich Einschränkungen finden Sie im *ArubaOS User Guide*.

Apparati Radio LAN a bassa Potenza, operanti a 2.4 GHz e 5 GHz. Fare riferimento alla *ArubaOS User Guide* per avere informazioni dettagliate sulle restrizioni.

Pre-Installation Network Requirements

After WLAN planning is complete and the appropriate products and their placement have been determined, the Aruba controller(s) must be installed and initial setup performed before the Aruba APs are deployed.

For initial setup of the controller, refer to the *ArubaOS Quick Start Guide* for the software version installed on your controller.

AP Pre-Installation Checklist

Before installing your IAP-92/IAP-93 access point, be sure that you have the following:

- CAT5 UTP cable of required length
- One of the following power sources:
 - IEEE 802.3af-compliant Power over Ethernet (PoE) source
 - Aruba AP AC-DC adapter kit (sold separately)
- Aruba Controller provisioned on the network:
 - Layer 2/3 network connectivity to your access point

One of the following network services:

- Aruba Discovery Protocol (ADP)
- DNS server with an "A" record
- DHCP Server with vendor-specific options

Summary of the Setup Process



It is important that you verify the items listed under AP Pre-Installation Checklist before you attempt to set up and install an IAP-92/IAP-93.

Successful setup of an IAP-92/IAP-93 access point consists of five tasks, which must be performed in this order:

1. Verify pre-installation connectivity.
2. Identify the specific installation location for each AP.
3. Install each AP.
4. Verify post-installation connectivity.
5. Configure each AP.



Aruba Networks, Inc., in compliance with governmental requirements, has designed the IAP-92/IAP-93 access points so that only authorized network administrators can change the settings. For more information about AP configuration, refer to the *ArubaOS Quick Start Guide* and *ArubaOS User Guide*.



Access points are radio transmission devices and as such are subject to governmental regulation. Network administrators responsible for the configuration and operation of access points must comply with local broadcast regulations. Specifically, access points must use channel assignments appropriate to the location in which the access point will be used.

Verifying Pre-Installation Connectivity

Before you install APs in a network environment, make sure that the APs are able to locate and connect to the controller after power on. Specifically, you must verify the following conditions:

- When connected to the network, each AP is assigned a valid IP address
- APs are able to locate the controller

Refer to the *ArubaOS Quick Start Guide* for instructions on locating and connecting to the controller.

Identifying Specific Installation Locations

You can mount the IAP-92/IAP-93 access point on a wall or on the ceiling. Use the AP placement map generated by Aruba's RF Plan software application to determine the proper installation location(s). Each location should be as close as possible to the center of the intended coverage area and should be free from obstructions or obvious sources of interference. These RF absorbers/reflectors/interference sources will impact RF propagation and should have been accounted for during the planning phase and adjusted for in RF plan.

Identifying Known RF Absorbers/Reflectors/Interference Sources

Identifying known RF absorbers, reflectors, and interference sources while in the field during the installation phase is critical. Make sure that these sources are taken into consideration when you attach an AP to its fixed location.

RF absorbers include:

- Cement/concrete—Old concrete has high levels of water dissipation, which dries out the concrete, allowing for potential RF propagation. New concrete has high levels of water concentration in the concrete, blocking RF signals.
- Natural Items—Fish tanks, water fountains, ponds, and trees
- Brick

RF reflectors include:

- Metal Objects—Metal pans between floors, rebar, fire doors, air conditioning/heating ducts, mesh windows, blinds, chain link fences (depending on aperture size), refrigerators, racks, shelves, and filing cabinets.
- Do not place an AP between two air conditioning/heating ducts. Make sure that APs are placed below ducts to avoid RF disturbances.

RF interference sources include:

- Microwave ovens and other 2.4 or 5 GHz objects (such as cordless phones)
- Cordless headset such as those used in call centers or lunch rooms

Installing the AP



Installation and service of Aruba Networks products should be performed by Professional Installers. Additional antenna and transmit power information for Professional Installers can be found at <https://support.arubanetworks.com>.



If you are installing an IAP-92, be sure to attach the antennas before mounting the AP.

Using the Integrated Wall-Mounting Slots

The keyhole-shaped slots on the back of the AP can be used to attach the device upright to an indoor wall or shelf. When you choose the mounting location, allow additional space at the right of the unit for cables.

1. Since the ports are on the back of the device, make sure that you mount the AP in such a way that there is a clear path to the Ethernet port, such as a pre-drilled hole in the mounting surface.
2. At the mounting location, install two screws on the wall or shelf, 1 7/8 inches (4.7 cm) apart. If you are attaching the device to drywall, Aruba recommends using appropriate wall anchors (not included).
3. Align the mounting slots on the rear of the AP over the screws and slide the unit into place (see Figure 4).

Figure 4 Installing the IAP-92/IAP-93 Access Point on a Wall

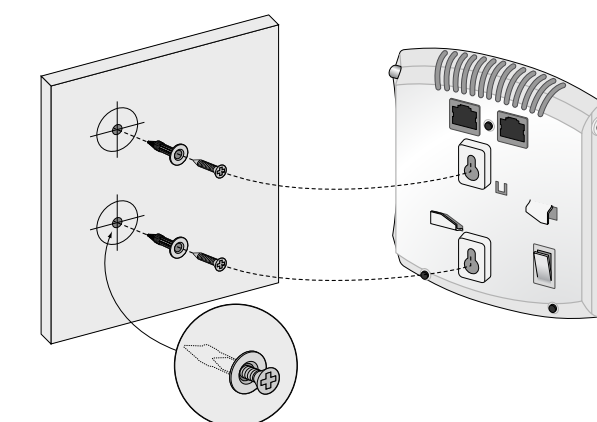

AP-92-003

Using the Integrated Ceiling Tile Rail Slots

The snap-in tile rail slots on the rear of the AP can be used to securely attach the device directly to a 15/16" wide, standard ceiling tile rail.



Make sure the AP fits securely on the ceiling tile rail when hanging the device from the ceiling; poor installation could cause it to fall.

1. Pull the necessary cables through a prepared hole in the ceiling tile near where the AP will be placed.
2. If necessary, connect the console cable to the console port on the back of the AP.
3. Hold the AP next to the ceiling tile rail with the ceiling tile rail mounting slots at approximately a 30-degree angle to the ceiling tile rail (see Figure 5). Make sure that any cable slack is above the ceiling tile.

Figure 5 Orienting the Ceiling Tile Rail Mounting Slots

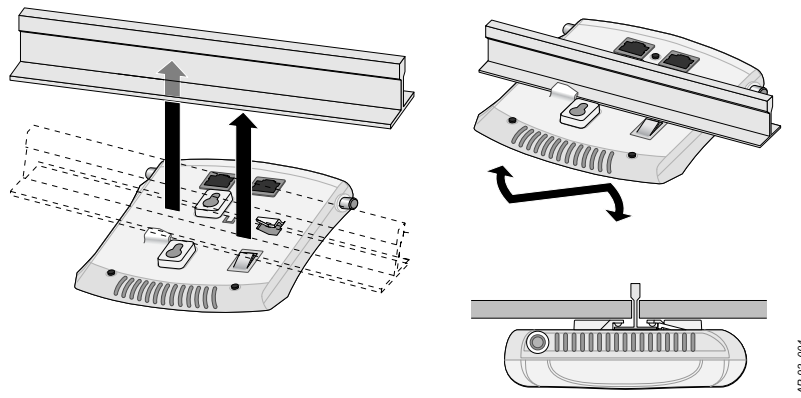

4. Pushing toward the ceiling tile, rotate the AP clockwise until the device clicks into place on the ceiling tile rail.

Connecting Required Cables

Install cables in accordance with all applicable local and national regulations and practices.

Ethernet Ports

The RJ45 Ethernet port (ENET) supports 10/100/1000Base-T auto-sensing MDI/MDX connections. Use these ports to connect the AP to a twisted pair Ethernet LAN segment or directly to an Aruba Controller. Use a 4- or 8-conductor, Category 5 UTP cable up to 100 m (325 feet) long.

The 10/100/1000 Mbps Ethernet port is on the back of the AP. The port has an RJ-45 female connector with the pin-outs shown in .

Figure 6 Gigabit Ethernet Port Pin-Out

1000Base-T Gigabit Ethernet Port	RJ-45 Female Pin-Out	Signal Name	Function
	1	BI_DA+	Bi-directional pair +A
	2	BI_DA-	Bi-directional pair -A
	3	BI_DB+	Bi-directional pair +B
	4	BI_DC+	Bi-directional pair +C
	5	BI_DC-	Bi-directional pair -C
	6	BI_DB-	Bi-directional pair -B
	7	BI_DD+	Bi-directional pair +D
	8	BI_DD-	Bi-directional pair -D

Serial Console Port

The serial console port (Console) allows you to connect the AP to a serial terminal or a laptop for direct local management. This port is an RJ-45 female connector with the pinouts described in Figure 7. Connect this port directly to a terminal or terminal server using an Ethernet cable.

Use a modular adapter to convert the RJ-45 (female) connector on the AP to a DB-9 (male) connector, and connect the adapter to a laptop using an RS-232 cable. See Figure 8 for connector details of the adapter.

Figure 7 Serial Port Pin-Out

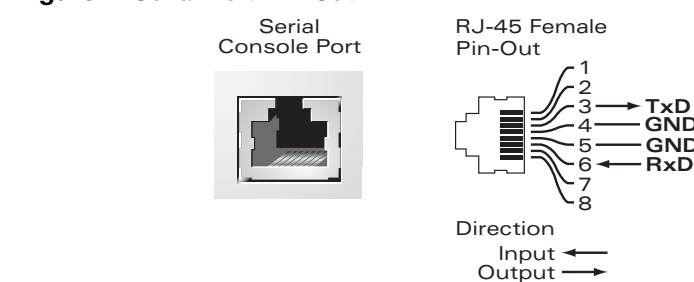
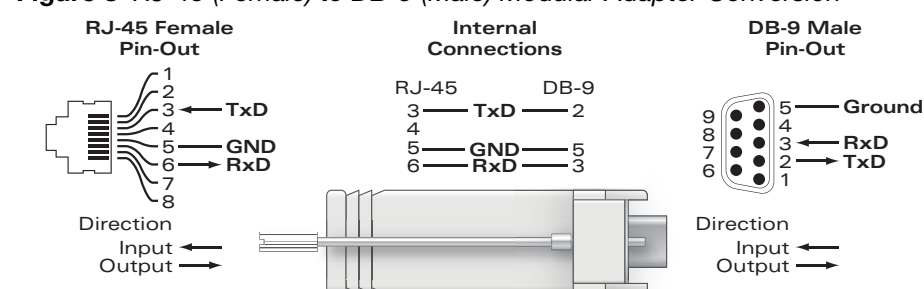

Figure 8 RJ-45 (Female) to DB-9 (Male) Modular Adapter Conversion



Power Connection

The IAP-92/IAP-93 has a single 12V DC power jack socket to support powering through an AC-to-DC power adapter.



If both POE and DC power are available, the AP uses POE even when there is not enough POE voltage available to power the AP.

Verifying Post-Installation Connectivity

The integrated LEDs on the AP can be used to verify that the AP is receiving power and initializing successfully (see Table 1). Refer to the *ArubaOS Quick Start Guide* for further details on verifying post-installation network connectivity.

Table 1 IAP-92/IAP-93 Series LED Meanings

LED	Color/State	Meaning
PWR	Off	No power to AP
	Green flashing	System initializing
	Red steady	System failed to initialize, contact TAC
	Green steady	Power on, device ready
ENET (10/100/1000 Mbps)	Off	No link
	Green on	1000 Mbps link
	Amber on	10/100 Mbps link
11A/N	Off	5 GHz radio is disabled
	Amber	5 GHz radio enabled in WLAN mode
	Green	5 GHz radio enabled in 11n mode
	Green flashing	5 GHz Air Monitor or RF Protect mode
	Green flashing	5 GHz Air Monitor or RF Protect mode
11B/G/N	Off	2.4 GHz radio disabled
	Amber	2.4 GHz radio enabled in WLAN mode
	Green	2.4 GHz radio enabled in 11n mode
	Green flashing	2.4 GHz Air Monitor or RF Protect mode

Product Specifications

Electrical

- Ethernet:
 - 1 x 10/100/1000Base-T auto-sensing Ethernet RJ-45 Interfaces
 - MDI/MDX
 - IEEE 802.3 (10Base-T), IEEE 802.3u (100Base-T), IEEE 802.3ab (1000Base-T)
 - Power over Ethernet (IEEE 802.3af compliant), 48V DC/350mA (see Figure 6 for pin configuration)
- Power:
 - 12 VDC power interface, supports powering through an AC-to-DC power adapter



If a power adapter other than the one provided by Aruba Networks is used in the US or Canada, it should be cULus (NRTL) Listed, with an output rated 12 VDC, minimum 1.25A, marked "LPS" or "Class 2," and suitable for plugging into a standard power receptacle in the US and Canada.

For additional specifications on this product, please refer to the data sheet. The data sheet can be found at www.arubanetworks.com.

Proper Disposal of Aruba Equipment

For the most current information about Global Environmental Compliance and Aruba products, see our website at www.arubanetworks.com.

Waste of Electrical and Electronic Equipment

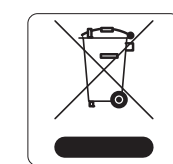

Aruba products at end of life are subject to separate collection and treatment in the EU Member States, Norway, and Switzerland and therefore are marked with the symbol shown at the left (crossed-out wheeled bin). The treatment applied at end of life of these products in these countries shall comply with the applicable national laws of countries implementing Directive 2002/96/EC on Waste of Electrical and Electronic Equipment (WEEE).

European Union RoHS

Aruba products also comply with the EU Restriction of Hazardous Substances Directive 2002/95/EC (RoHS). EU RoHS restricts the use of specific hazardous materials in the manufacture of electrical and electronic equipment. Specifically, restricted materials under the RoHS Directive are Lead (including

Solder used in printed circuit assemblies), Cadmium, Mercury, Hexavalent Chromium, and Bromine. Some Aruba products are subject to the exemptions listed in RoHS Directive Annex 7 (Lead in solder used in printed circuit assemblies). Products and packaging will be marked with the "RoHS" label shown at the left indicating conformance to this Directive.

China RoHS



Aruba products also comply with China environmental declaration requirements and are labeled with the "EFUP 10" label shown at the left.

有毒有害物质声明 Hazardous Materials Declaration

部件名称 (Parts)	有毒有害物质或元素 (Hazardous Substance)					
	铅 (Pb)	汞 (Hg)	镉 (Cd)	六价铬 (Cr ⁶⁺)	多溴联苯 (PBB)	多溴二苯醚 (PBDE)
电路板 (PCB Boards)	×	○	○	○	○	○
机械组件 (Mechanical Sub-Assemblies)	×	○	○	○	○	○

○: 表示该有害物质在该部件所有均质材料中的含量均在 SJ/T11363-2006 标准规定的限量要求以下。
Indicates that the concentration of the hazardous substance in all homogeneous materials in the parts is below the relevant threshold of the SJ/T11363-2006 standard.

×: 表示该有害物质至少在该部件的某一均质材料中的含量超出 SJ/T11363-2006 标准规定的限量要求。
Indicates that the concentration of the hazardous substance of at least one of all homogeneous materials in the parts is above the relevant threshold of the SJ/T11363-2006 standard.

对销售之目的所售产品, 本表显示, 供应链的电子产品信息可能包含这些物质。
This table shows where these substances may be found in the supply chain of electronic information products, as of the date of sale of the enclosed product.

此标志为针对所涉产品的环保使用期标志。某些零件会有一个不同的环保使用期 (例如, 电池单元模块) 贴在其产品上。
此环保使用期只适用于产品在产品手册中所规定的条件下工作。
The Environment-Friendly Use Period (EFUP) for all enclosed products and their parts are per the symbol shown here. The Environment-Friendly Use Period is valid only when the product is operated under the conditions defined in the product manual.

Safety and Regulatory Compliance

Aruba Networks provides a multi-language document that contains country-specific restrictions and additional safety and regulatory information for all Aruba access points. This document can be viewed or downloaded from the following location: www.arubanetworks.com/safety_addendum

The device will be electronically labeled and the FCC ID will be displayed via the controller WebUI under the **About** menu.



Aruba access points must be installed by a professional installer. The professional installer is responsible for ensuring that grounding is available and it meets applicable local and national electrical codes.



RF Radiation Exposure Statement: This equipment complies with FCC RF radiation exposure limits. This equipment should be installed and operated with a minimum distance of 7.87 inches (20cm) between the radiator and your body for 2.4 GHz and 5 GHz operations. This transmitter must not be co-located or operating in conjunction with any other antenna or transmitter. When operated in the 5.15 to 5.25 GHz frequency range, this device is restricted to indoor use.

EMC Compliance and Warning Statement

- IEC 60601-1-2: 2007
- EN 60601-1-2: 2007

This equipment has been tested and found to comply with the limits of the standard for medical devices, IEC 60601-1-2:2007. The unit also complies with the requirements of EN 60601-1-2:2007, providing the presumption of compliance to the European Union's Medical Device Directive 2007/47/EC. The limits are designed to provide reasonable protection against harmful interference in a typical medical installation. This equipment generates, uses and can radiate radio frequency energy, and, if not installed and used in accordance with the manufacturer's instructions may cause harmful interference to other devices in the vicinity. However, there is no guarantee that interference will not occur in a particular installation. If this equipment causes interference with other devices, which may be determined by turning the equipment off and on, the user is encouraged to try and correct the interference by one or more of the following measures:

- Reorient or relocate the device receiving the interference.
- Increase the separation between the equipment.
- Connect the equipment into an outlet on a circuit different from that to which the other device(s) are connected.
- Consult the manufacturer or field service technician for help.

The Models IAP-92 and IAP-93 do not have an Applied Part as defined in IEC 60601-1. The protection against electric shock is Class II.

Device is not protected against ingress of liquids and has a protection class of IPX0 as defined by IEC 60601-1 and IEC 60529. Equipment not suitable for use in the presence of flammable mixtures.

The unit is considered "Continuous Operation" equipment as defined by IEC 60601-1.

Power Consumption – 48 VDC 802.3af power over Ethernet or 12VDC, 1.25A for external AC supplied power (adapter sold separately); Maximum power consumption - 10W.

Mechanical Dimensions: 120mm x 130mm x 55mm; 255g.

IAP-92 and IAP-93 Wireless Access Point Installation Guide



Contacting Aruba Networks

Table 1

Web Site Support	
Main Site	http://www.arubanetworks.com
Support Site	https://support.arubanetworks.com
Software Licensing Site	https://licensing.arubanetworks.com/login.php
Wireless Security Incident Response Team (WSIRT)	http://www.arubanetworks.com/support/wsirt.php
Americas and APAC Support Email	support@arubanetworks.com
EMEA Support Email	emea.support@arubanetworks.com
WSIRT Email Please email details of any security problem found in an Aruba product.	wsirt@arubanetworks.com

Table 2

Telephone Support	
Aruba Corporate	+1 (408) 227-4500
FAX	+1 (408) 227-4550

Copyright

© 2010 Aruba Networks, Inc. AirWave®, Aruba Networks®, Aruba Mobility Management System®, BlueScanner, For Wireless That Works®, Mobile Edge Architecture, People Move, Networks Must Follow., RFPProtect®, The All Wireless Workplace Is Now Open For Business, and The Mobile Edge Company® are trademarks of Aruba Networks, Inc. All rights reserved. All other trademarks are the property of their respective owners.

Open Source Code

Certain Aruba products include Open Source software code developed by third parties, including software code subject to the GNU General Public License ("GPL"), GNU Lesser General Public License ("LGPL"), or other Open Source Licenses. The Open Source code used can be found at this site: http://www.arubanetworks.com/open_source

Legal Notice

The use of Aruba Networks, Inc. switching platforms and software, by all individuals or corporations, to terminate other vendors' VPN client devices constitutes complete acceptance of liability by that individual or corporation for this action and indemnifies, in full, Aruba Networks, Inc. from any and all legal actions that might be taken against it with respect to infringement of copyright on behalf of those vendors.

Warranty

his hardware product is protected by the Aruba Limited Lifetime warranty. Altering this device (such as painting it) voids the warranty.



www.arubanetworks.com
1344 Crossman Avenue
Sunnyvale, California 94089
Phone: 408.227.4500
Fax: 408.227.4550

IAP-92 and IAP-93 Wireless Access Point | Installation Guide
Part Number 0510863-01 | January 2011