

Aruba AP-93H Wireless Access Point

Installation Guide

The Aruba AP-93H are single-radio, dual-band wireless access point that supports the IEEE 802.11n standard for high-performance WLAN. This access point uses MIMO (Multiple-in, Multiple-out) technology and other high-throughput mode techniques to deliver high-performance, 802.11n 2.4 GHz or 5 GHz functionality while simultaneously supporting existing 802.11a/b/g wireless services. The AP-93H access point works only in conjunction with an Aruba Controller.

The Aruba AP-93H access point provides the following capabilities:

- Wireless transceiver
- Protocol-independent networking functionality
- IEEE 802.11a/b/g/n operation as a wireless access point
- IEEE 802.11a/b/g/n operation as a wireless air monitor
- Compatibility with IEEE 802.3af PoE
- Central management configuration and upgrades through an Aruba Controller



The Aruba AP-93H requires ArubaOS 6.1.3 or later.

Package Contents

- AP-93H Access Point
- AP-93H Mounting Bracket
- 1x Security Screw
- 2x Cat5e Ethernet cable (length 0.1m)
- Installation Guide



Inform your supplier if there are any incorrect, missing, or damaged parts. If possible, retain the carton, including the original packing materials. Use these materials to repack and return the unit to the supplier if needed.

AP-93H Hardware Overview

Figure 1 Top

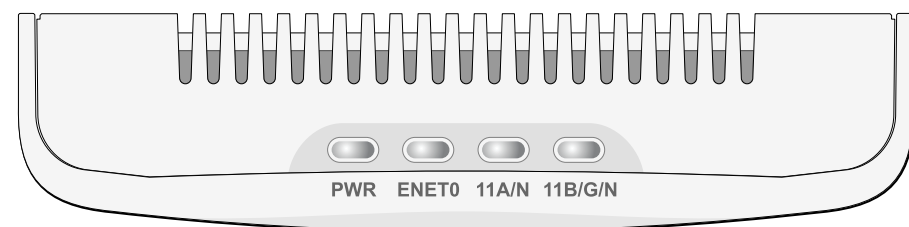

LEDs

- PWR: Indicates whether or not the AP-93H is powered-on
- ENET 0: Indicates the status of ENET 0
- 11A/N: Indicates the status of the 802.11a/n radio
- 11B/G/N: Indicates the status of the 802.11b/g/n radio

For information about the AP-93H's LED behavior, see [Table 1](#).

Figure 2 Rear

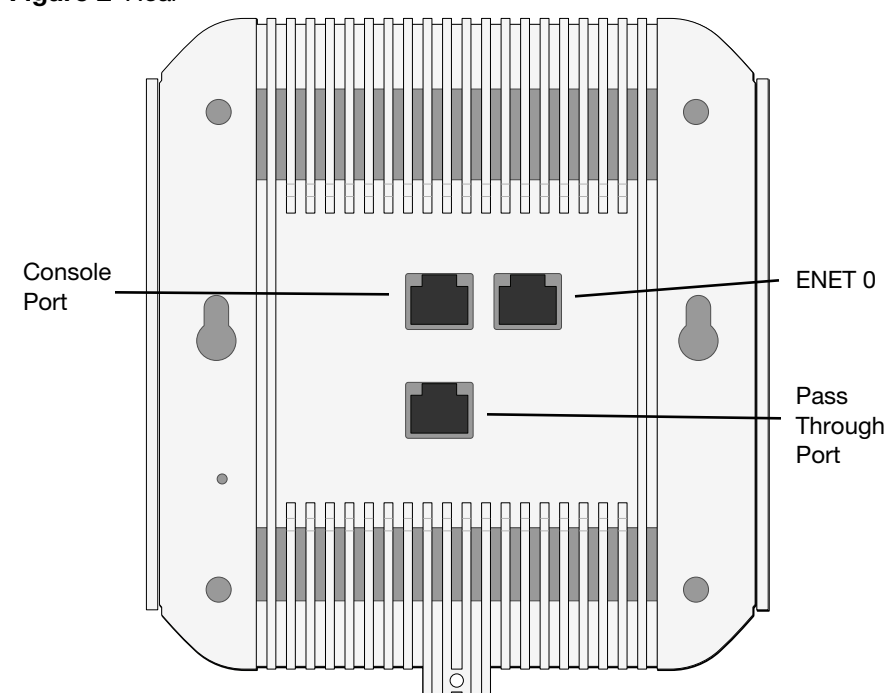

Serial Console Port

The serial console port (Console) allows you to connect the AP to a serial terminal or a laptop for direct local management. This port is an RJ-45 female

connector with the pin-outs described in [Figure 3](#). Connect this port directly to a terminal or terminal server using an Ethernet cable.

Figure 3 Serial Port Pin-Out

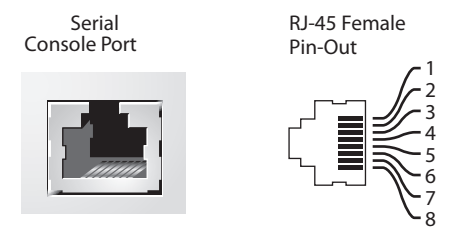
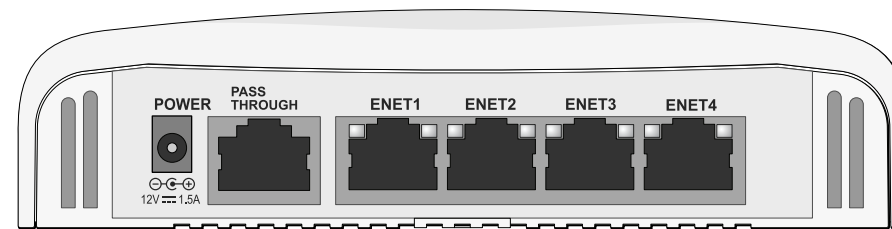

Figure 4 Bottom



Ethernet Ports

AP-93H is equipped with a total of five active Ethernet ports (ENET 0-5). ENET 0 is a 10/100/1000Base-T (RJ-45) auto-sensing, MDI/MDX wired-network uplink connectivity port. This port supports IEEE 802.3af Power over Ethernet (PoE), accepting 48VDC as a standard defined Powered Device (PD) from a Power Sourcing Equipment (PSE) such as a PoE midspan injector or network infrastructure that supports PoE. ENET 1 through 4 are 10/100Base-T (RJ-45) auto-sensing, MDI/MDX wired-network downlink connectivity ports, used to provide secure network connectivity to wired devices. ENET 0 is located on the rear of the AP, while ENET 1-4 are located on the bottom ([Figure 4](#)).

Additionally, AP-93H supports a passive pass-through RJ-45 interface to extend a physical connection (typically another Ethernet connection) from the back of the device to a connector on the bottom.

Figure 5 Gigabit Ethernet Port Pin-Out

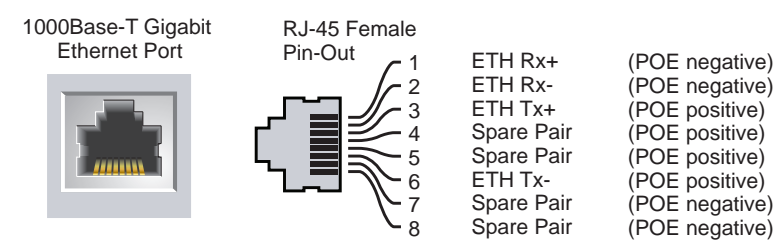
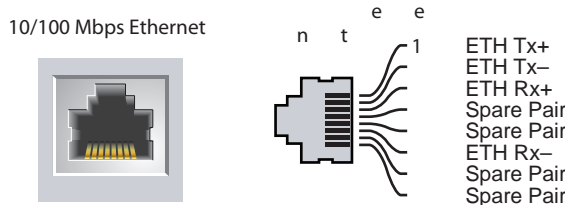

Figure 6 Fast Ethernet Port Pin-Out



DC Power Socket

The AP-93H has a single 12V DC power jack socket to support powering through an AC-to-DC power adapter.



If both POE and DC power are available, the AP uses POE even when there is not enough POE voltage available to power the AP.

Reset Button

The reset button can be used to return the AP to factory default settings. To reset the AP:

1. Power off the AP.
2. Press and hold the reset button using a small, narrow object, such as a paperclip.
3. Power-on the AP without releasing the reset button. The power LED will flash within 5 seconds.
4. Release the reset button.

The power LED will flash again within 15 seconds indicating that the reset is completed. The AP will now continue to boot with the factory default settings.

Before You Begin



FCC Statement: Improper termination of access points installed in the United States configured to non-US model controllers will be in violation of the FCC grant of equipment authorization. Any such willful or intentional violation may result in a requirement by the FCC for immediate termination of operation and may be subject to forfeiture (47 CFR 1.80).



EU Statement: Lower power radio LAN product operating in 2.4 GHz and 5 GHz bands. Please refer to the *ArubaOS User Guide* for details on restrictions.



Produit réseau local radio basse puissance operant dans la bande fréquence 2.4 GHz et 5 GHz. Merci de vous référer au *ArubaOS User Guide* pour les détails des restrictions.

Low Power FunkLAN Produkt, das im 2.4 GHz und im 5 GHz Band arbeitet. Weitere Informationen bezüglich Einschränkungen finden Sie im *ArubaOS User Guide*.

Apparati Radio LAN a bassa Potenza, operanti a 2.4 GHz e 5 GHz. Fare riferimento alla *ArubaOS User Guide* per avere informazioni dettagliate sulle restrizioni.

Pre-Installation Network Requirements

After WLAN planning is complete and the appropriate products and their placement have been determined, the Aruba controller(s) must be installed and initial setup performed before the Aruba APs are deployed.

AP Pre-Installation Checklist

Before installing your AP-93H access point, be sure that you have the following:

- Pre-installed wall box
- Cat5 UTP cable with network access installed in the wall box
- One of the following power sources:
 - IEEE 802.3af-compliant Power over Ethernet (PoE) source
 - Aruba AP AC-DC adapter kit (sold separately)
- Aruba Controller provisioned on the network:
 - Layer 2/3 network connectivity to your access point

One of the following network services:

- Aruba Discovery Protocol (ADP)
- DNS server with an "A" record
- DHCP Server with vendor-specific options

Summary of the Setup Process



It is important that you verify the items listed under [AP Pre-Installation Checklist](#) before you attempt to set up and install an AP-93H.

Successful setup of an AP-93H access point consists of five tasks, which must be performed in this order:

1. Verify pre-installation connectivity.
2. Identify the specific installation location for each AP.
3. Install each AP.
4. Verify post-installation connectivity.
5. Configure each AP.



Aruba Networks, Inc., in compliance with governmental requirements, has designed the AP-93H access points so that only authorized network administrators can change the settings. For more information about AP configuration, refer to the *ArubaOS Quick Start Guide* and *ArubaOS User Guide*.



Access points are radio transmission devices and as such are subject to governmental regulation. Network administrators responsible for the configuration and operation of access points must comply with local broadcast regulations. Specifically, access points must use channel assignments appropriate to the location in which the access point will be used.

Verifying Pre-Installation Connectivity

Before you install APs in a network environment, make sure that the APs are able to locate and connect to the controller after power on. Specifically, you must verify the following conditions:

- When connected to the network, each AP is assigned a valid IP address
- APs are able to locate the controller

Refer to the *ArubaOS Quick Start Guide* for instructions on locating and connecting to the controller.

Identifying Specific Installation Locations

You can mount the AP-93H access point on a wall or on the ceiling. Use the AP placement map generated by Aruba's RF Plan software application to determine the proper installation location(s). Each location should be as close as possible to the center of the intended coverage area and should be free from obstructions or obvious sources of interference. These RF absorbers/reflectors/interference sources will impact RF propagation and should have been accounted for during the planning phase and adjusted for in RF plan.

Identifying Known RF Absorbers/Reflectors/Interference Sources

Identifying known RF absorbers, reflectors, and interference sources while in the field during the installation phase is critical. Make sure that these sources are taken into consideration when you attach an AP to its fixed location.

RF absorbers include:

- Cement/concrete—Old concrete has high levels of water dissipation, which dries out the concrete, allowing for potential RF propagation. New concrete has high levels of water concentration in the concrete, blocking RF signals.
- Natural Items—Fish tanks, water fountains, ponds, and trees
- Brick

RF reflectors include:

- Metal Objects—Metal pans between floors, rebar, fire doors, air conditioning/heating ducts, mesh windows, blinds, chain link fences (depending on aperture size), refrigerators, racks, shelves, and filing cabinets.
- Do not place an AP between two air conditioning/heating ducts. Make sure that APs are placed below ducts to avoid RF disturbances.

RF interference sources include:

- Microwave ovens and other 2.4 or 5 GHz objects (such as cordless phones)
- Cordless headset such as those used in call centers or lunch rooms

Installing the AP



The following procedure describes a typical installation using a standard United States wall box.

The AP-93H is designed to mount into a variety of electrical gang boxes. To install your AP-93H:

1. Begin by removing the existing data wall plate (if applicable).

Figure 7 Removing the Wall Plate

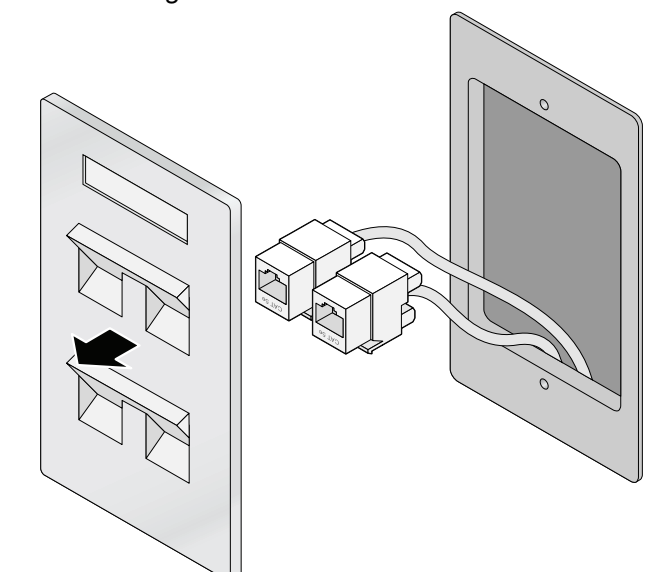

2. Remove any existing RJ45 connectors (typically snap-in) or cut/remove the UTP cable.
3. Use the short Ethernet cables supplied with the AP-93H to connect the AP to the RJ45 connectors or crimp an RJ45 plug (not supplied) on the cable (or both cables if using the pass through).
4. Align the mounting holes of the AP-93H mounting bracket with mounting holes in your gang box as shown in [Figure 8](#).

Figure 8 Bracket to Gang Box (Standard US Single Gang Outlet Box Shown)

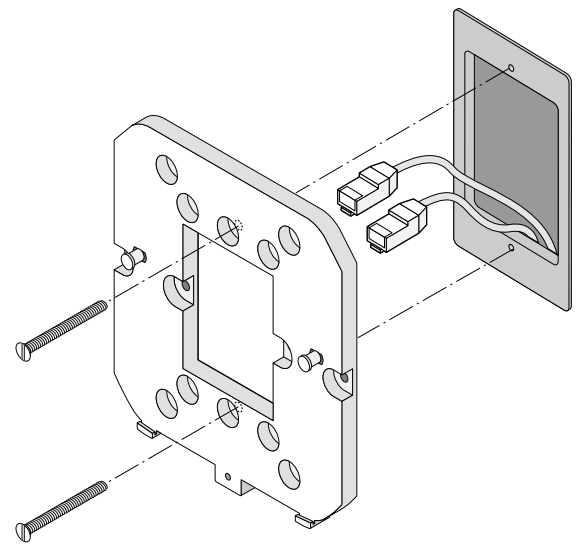

5. Connect any required cables to the rear of the AP-93H.
6. Align the mounting posts on the mounting bracket with the corresponding mounting holes on the back of your AP-93H as shown in Figure 9.

Figure 9 AP-93H to Bracket

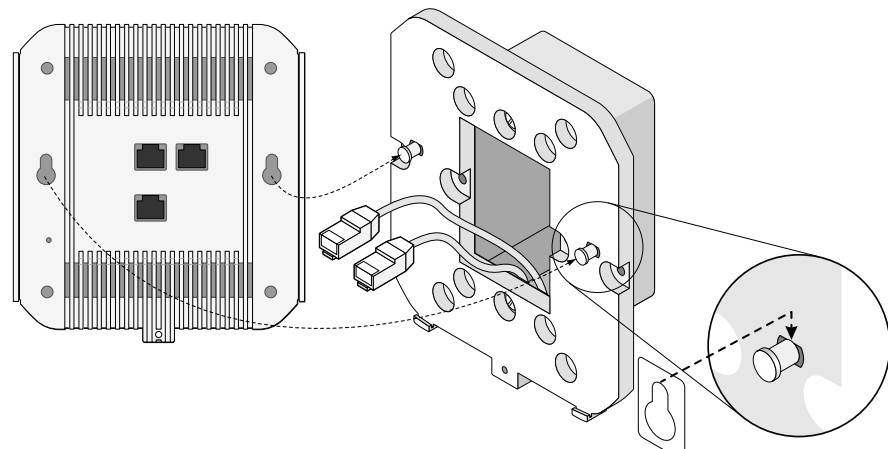

7. Securing your AP-93H to the mounting bracket using the enclosed security screw (see Figure 10).

Figure 10 Securing the AP-93H

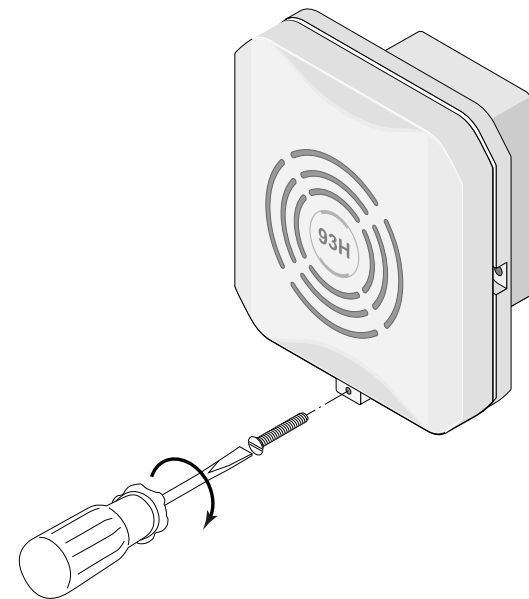

8. If not using PoE, connect the AC-DC power adapter (sold separately) to the DC power socket located on the bottom of the AP-93H.

Verifying Post-Installation Connectivity

The integrated LEDs on the AP can be used to verify that the AP is receiving power and initializing successfully (see Table 1). Refer to the *ArubaOS Quick Start Guide* for further details on verifying post-installation network connectivity.

Table 1 AP-93H Series LED Meanings

LED	Color/State	Meaning
PWR	Off	No power to AP
	Green flashing	System initializing
	Red steady	System failed to initialize, contact TAC
	Green steady	Power on, device ready
ENET 0	Off	No link
	Green on	1000 Mbps link
	Amber on	10/100 Mbps link
	Flashing	Ethernet link activity

Table 1 AP-93H Series LED Meanings (Continued)

LED	Color/State	Meaning
ENET 1-4	Off	No link
	Green on	10/100 Mbps link
	Flashing	Ethernet link activity
11A/N	Off	5 GHz radio is disabled
	Amber	5 GHz radio enabled in WLAN mode
	Green	5 GHz radio enabled in 11n mode
	Green flashing	5 GHz Air Monitor
11B/G/N	Off	2.4 GHz radio disabled
	Amber	2.4 GHz radio enabled in WLAN mode
	Green	2.4 GHz radio enabled in 11n mode
	Green flashing	2.4 GHz Air Monitor

Configuring the AP-93H

AP Provisioning/Reprovisioning

Provisioning parameters are unique to each AP. These local AP parameters are initially configured on the controller which are then pushed out to the AP and stored on the AP itself. Aruba recommends that provisioning settings be configured via the ArubaOS Web UI only. Refer to the *ArubaOS User Guide* for complete details.

AP Configuration

Configuration parameters are network or controller specific and are configured and stored on the controller. Network configuration settings are pushed out to the AP(s) but remain stored on the controller.

Configuration settings can be configured via the ArubaOS Web UI, ArubaOS CLI, or Aruba MMS. Refer to their respective guides for further details: the *ArubaOS User Guide* or *Aruba Mobility Management System User Guide*.

Product Specifications

Electrical

- Ethernet:
 - 1 x 10/100/1000Base-T auto-sensing Ethernet RJ-45 Interface (ENET 0)
 - 4 x 10/100Base-T auto-sensing Ethernet RJ-45 Interfaces (ENET 1)
 - MDI/MDX
 - IEEE 802.3 (10Base-T), IEEE 802.3u (100Base-T), IEEE 802.3ab (1000Base-T)
 - Power over Ethernet (IEEE 802.3af compliant), 48V DC/350mA (see Figure 5 for pin configuration)
- Power:
 - 48V DC 802.3af Power over Ethernet
 - 12 VDC power interface, supports powering through an AC-to-DC power adapter



If a power adapter other than the one provided by Aruba Networks is used in the US or Canada, it should be NRTL Listed, with an output rated 12 VDC, minimum 1.25A, marked "LPS" or "Class 2," and suitable for plugging into a standard power receptacle in the US and Canada.

For additional specifications on this product, please refer to the data sheet. The data sheet can be found at www.arubanetworks.com.

Proper Disposal of Aruba Equipment

For the most current information about Global Environmental Compliance and Aruba products, see our website at www.arubanetworks.com.

Waste of Electrical and Electronic Equipment



Aruba products at end of life are subject to separate collection and treatment in the EU Member States, Norway, and Switzerland and therefore are marked with the symbol shown at the left (crossed-out wheeled bin). The treatment applied at end of life of these products in these countries shall comply with the applicable national laws of countries implementing Directive 2002/96/EC on Waste of Electrical and Electronic Equipment (WEEE).

European Union RoHS



Aruba products also comply with the EU Restriction of Hazardous Substances Directive 2002/95/EC (RoHS). EU RoHS restricts the use of specific hazardous materials in the manufacture of electrical and electronic equipment. Specifically, restricted materials under the RoHS Directive are Lead (including Solder used in printed circuit assemblies), Cadmium, Mercury, Hexavalent Chromium, and Bromine. Some Aruba products are subject to the exemptions listed in RoHS Directive Annex 7 (Lead in solder used in printed circuit assemblies). Products and packaging will be marked with the "RoHS" label shown at the left indicating conformance to this Directive.

China RoHS



Aruba products also comply with China environmental declaration requirements and are labeled with the "EFUP 10" label shown at the left.

有毒有害物质声明 Hazardous Materials Declaration

部件名称 (Parts)	有毒有害物质或元素 (Hazardous Substance)				
	铅 (Pb)	汞 (Hg)	六价铬 (Cr ⁶⁺)	多溴联苯 (PBB)	多溴二苯醚 (PBDE)
电路板 (PCB Boards)	×	○	○	○	○
机械组件 (Mechanical Sub-Assemblies)	×	○	○	○	○

○: 表示该有害物质在该部件所有均质材料中的含量均在 SJ/T11363-2006 标准规定的限量要求以下。
Indicates that the concentration of the hazardous substance in all homogeneous materials in the parts is below the relevant threshold of the SJ/T11363-2006 standard.

×: 表示该有害物质至少在该部件的某一均质材料中的含量超出 SJ/T11363-2006 标准规定的限量要求。
Indicates that the concentration of the hazardous substance of at least one of all homogeneous materials in the parts is above the relevant threshold of the SJ/T11363-2006 standard.

对销售之目的所售产品, 本表显示, 供应链的电子产品信息可能包含这些物质。
This table shows where these substances may be found in the supply chain of electronic information products, as of the date of sale of the enclosed product.

此标志为针对所涉产品的环保使用期标志。某些零件会有一个不同的环保使用期 (例如, 电池单元模块) 贴在其产品上。
此环保使用期只适用于产品是在产品手册中所规定的条件下工作。
The Environment-Friendly Use Period (EFUP) for all enclosed products and their parts are per the symbol shown here. The Environment-Friendly Use Period is valid only when the product is operated under the conditions defined in the product manual.

Safety and Regulatory Compliance

Aruba Networks provides a multi-language document that contains country-specific restrictions and additional safety and regulatory information for all Aruba access points. This document can be viewed or downloaded from the following location: www.arubanetworks.com/safety_addendum



Aruba access points must be installed by a professional installer. The professional installer is responsible for ensuring that grounding is available and it meets applicable local and national electrical codes.



RF Radiation Exposure Statement: This equipment complies with FCC RF radiation exposure limits. This equipment should be installed and operated with a minimum distance of 7.87 inches (20cm) between the radiator and your body for 2.4 GHz and 5 GHz operations. This transmitter must not be co-located or operating in conjunction with any other antenna or transmitter. When operated in the 5.15 to 5.25 GHz frequency range, this device is restricted to indoor use.

EMC Compliance and Warning Statement

This equipment generates, uses and can radiate radio frequency energy, and, if not installed and used in accordance with the manufacturer's instructions may cause harmful interference to other devices in the vicinity. However, there is no guarantee that interference will not occur in a particular installation. If this equipment causes interference with other devices, which may be determined by turning the equipment off and on, the user is encouraged to try and correct the interference by one or more of the following measures:

- Reorient or relocate the device receiving the interference.
- Increase the separation between the equipment.
- Connect the equipment into an outlet on a circuit different from that to which the other device(s) are connected.
- Consult the manufacturer or field service technician for help.

The protection against electric shock is Class II.

Equipment not suitable for use in the presence of flammable mixtures.

Aruba AP-93H Wireless Access Point Installation Guide



Contacting Aruba Networks

Table 1

Web Site Support	
Main Site	http://www.arubanetworks.com
Support Site	https://support.arubanetworks.com
Software Licensing Site	https://licensing.arubanetworks.com/login.php
Wireless Security Incident Response Team (WSIRT)	http://www.arubanetworks.com/support/wsirt.php
Americas and APAC Support Email	support@arubanetworks.com
EMEA Support Email	emea.support@arubanetworks.com
WSIRT Email Please email details of any security problem found in an Aruba product.	wsirt@arubanetworks.com

Table 2

Telephone Support	
Aruba Corporate	+1 (408) 227-4500
FAX	+1 (408) 227-4550
Support United States Universal Free Phone Service Number (JIFN): Australia, Canada, China, France, Germany, Hong Kong, Ireland, Israel, Japan, Korea, Singapore, South Africa, Taiwan, and the UK	800-WI-FI-LAN (800-943-4526) +800-4WIFI-LAN (+800-49434-526)
All Other Countries	+1 (408) 754-1200

Copyright

© 2011 Aruba Networks, Inc. AirWave®, Aruba Networks®, Aruba Mobility Management System®, Bugscanner, For Wireless That Works®, Mobile Edge Architecture, People Move, Networks Must Follow®, RFprotect®, The All Wireless Workplace Is Now Open For Business, and The Mobile Edge Company® are trademarks of Aruba Networks, Inc. All rights reserved. All other trademarks are the property of their respective owners.

Open Source Code

Certain Aruba products include Open Source software code developed by third parties, including software code subject to the GNU General Public License (GPL), GNU Lesser General Public License (LGPL), or other Open Source Licenses. The Open Source code used can be found at this site: http://www.arubanetworks.com/open_source

Legal Notice

The use of Aruba Networks, Inc. switching platforms and software, by all individuals or corporations, to terminate other vendors' VPN client devices constitutes complete acceptance of liability by that individual or corporation for this action and indemnifies, in full, Aruba Networks, Inc. from any and all legal actions that might be taken against it with respect to infringement of copyright on behalf of those vendors.

Warranty

This hardware product is protected by the standard Aruba warranty of one year parts/labor. For more information, refer to the ARUBACARE SERVICE AND SUPPORT TERMS AND CONDITIONS. Altering this device (such as painting it) voids the warranty.



www.arubanetworks.com
1344 Crossman Avenue
Sunnyvale, California 94089
Phone: 408.227.4500
Fax 408.227.4550