

Aruba 340 Series Campus Access Point

Installation Guide

Aruba 340 Series Campus Access Point 340 Series (AP-344 and AP-345) are high-performance dual-radio wireless devices. These access points (AP) provide secure wireless connectivity for 2.4GHz 802.11 b/g/n and 5GHz 802.11a/n/ac Wi-Fi networks. The optional dual-5GHz radio mode allows both radios to operate in the 5GHz radio mode simultaneously, doubling the 5GHz capacity of the access point. The 340 Series can be deployed in either a controller-based (ArubaOS) or controllerless (InstantOS) network environment. Two wired Ethernet ports located on the back of this access point are available to connect the access point to the wired infrastructure and to deliver power the device.

This access point can be attached to a standard flat 9/16" or 15/16" suspended ceiling rail using the mount adapters provided. Other mounting options are supported by additional mount kits (sold separately).

Aruba 340 Series Campus Access Point 340 Series provide the following capabilities:

- Wireless access
- Wireless mesh
- Air monitor
- Spectrum monitor
- Support for selected USB peripherals
- Integrated Bluetooth Low Energy (BLE) radio

Package Contents

The following materials are included with this product:

- Startup Guide
- Aruba 340 Series Campus Access Point
- 9/16" and 15/16" ceiling rail mount adapters
- Declaration of Conformity document
- End-User License Agreement document



Inform your supplier if there are any incorrect, missing, or damaged parts. If possible, retain the carton, including the original packing materials. Use these materials to repack and return the unit to the supplier if needed.

Hardware Overview

The following sections describe the hardware components of the 340 Series access point.

Figure 1 Aruba AP-345 (front view)



LED

The LED displays located on the front panel of the access point indicate the following functions:

System Status

The System Status LED indicates the operating condition of the access point, See [Table 1](#).

Table 1 System Status LED

Color/State	Meaning
Off	Device is powered off
Green - blinking ¹	Device is booting; not ready
Green - solid	Device is ready; fully functional, no network restrictions
Green - flashing ²	Device is ready; either uplink is negotiating at suboptimal speed (<1Gbps)
Amber - solid	Device is ready; operating in Power Save mode due to one of the following conditions: <ul style="list-style-type: none">powered by an 802.3af POE sourceIntelligent Power Monitoring (IPM) restrictions applied No network restrictions
Amber - flashing	Device is ready; operating in Power Save mode due to one of the following conditions: <ul style="list-style-type: none">powered by an 802.3af POE sourceIntelligent Power Monitoring (IPM) restrictions applied Either uplink is negotiating at suboptimal speed (<1Gbps)
Red - solid	Error condition - immediate action required

¹ Blinking: one second on/one second off

² Flashing: mostly on, shortly off every two seconds

Radio Status

The Radio Status LED indicates the operating mode of the access point's radios. See [Table 2](#).

Table 2 Radio Status LED

Color/State	Meaning
Off	Meets one of the following conditions: <ul style="list-style-type: none">device is powered offboth radios are disabled
Green - solid	Both radios operating in access mode
Green - blinking	One radio operating in access mode; one radio disabled
Amber - solid	Both radios operating in monitor mode
Amber - blinking	One radio operating in monitor mode; one radio disabled
Alternating ³	One radio operating in access mode; one radio in monitor mode
Blue - Solid	Both radios operating in dual 5GHz mode

³ Alternating: light cycles alternate between green/amber; one second on/one second off.

LED Display Settings

The LEDs have three operating modes that can be selected in the system management software:

- Default mode: Refer to [Table 2](#)
- Off mode: LEDs are off
- Blink mode: LEDs blink green

Antenna Connectors

AP-344 supports up to 8 external antennas, which can be attached to the RP-SMA connectors located on the front of the access point. See [Figure 2](#).

The primary antenna ports, labeled A0-A3, correspond with the radio chains 0, 1, 2, and 3. This set of antennas can be used in dual-radio mode (dual band, diplexed), for either upper or lower 5GHz channels in dual-5GHz mode.

The secondary antenna ports, labeled B0-B3, correspond with radio chains 0, 1, 2, and 3. This set of antennas can be used for either upper or lower 5GHz channels in dual-5GHz mode, but are unable to operate in dual-radio mode. These connectors are located beneath a removable plate on the front cover of the device. To remove the cover, insert a flathead screwdriver into the slotted rubber bushing located on the top edge of the access point, then use the screwdriver to pry off the cover.

To determine which external antennas are compatible with this device, refer to the product data sheet at arubanetworks.com.

Figure 2 Aruba AP-344 (front view)

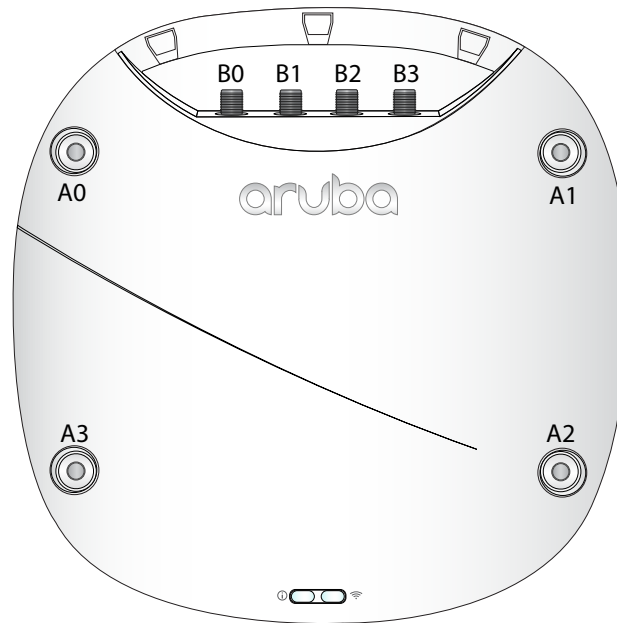

RF Radiation Exposure Statement: This equipment complies with FCC RF radiation exposure limits. This equipment should be installed and operated with a minimum distance of 10.63 inches (27cm) between the radiator and your body for 2.4 GHz and 5 GHz operations. This transmitter must not be co-located or operating in conjunction with any other antenna or transmitter. When operated in 5.15 to 5.25 GHz frequency range, this device is restricted to indoor use to reduce the potential for harmful interference with co-channel Mobile Satellite Systems.



CAUTION

Déclaration sur les limites d'exposition aux radiofréquences : cet équipement est conforme aux limites d'exposition aux rayonnements radioélectriques spécifiées par la FCC. Il doit être installé et utilisé à une distance minimale de 27 cm par rapport à votre corps pour les fréquences de 2,4 et 5 GHz. Cet émetteur-récepteur ne doit pas être utilisé ou situé à proximité d'autres antennes ou émetteurs-récepteurs. En cas d'utilisation dans la plage de fréquences de 5,15 à 5,25 GHz, cet appareil doit uniquement être utilisé en intérieur afin de réduire les risques d'interférence avec les systèmes satellites mobiles partageant le même canal.

Figure 3 Aruba 340 Series (rear view)

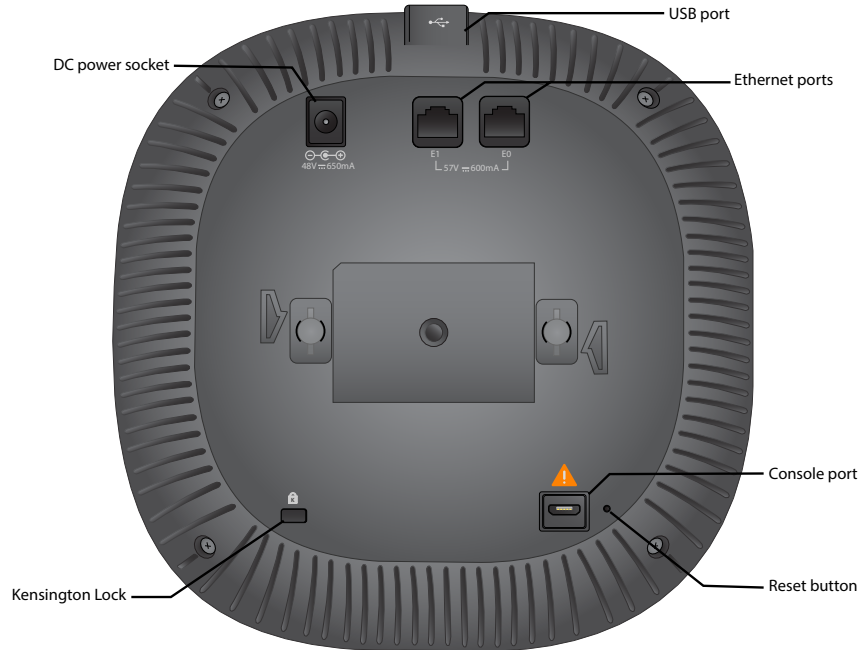

Console Port

The 5-pin Micro-B connector located on the bottom of this device. Use an AP-CBL-SERU cable for direct management of this device when connected to a laptop or serial console. For port pin-out details, refer to [Figure 4](#).

Figure 4 Micro-B Port Pin-out

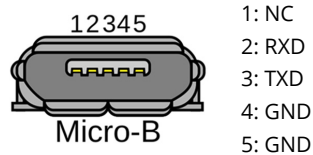

Ethernet Ports

The Aruba 340 Series access point is equipped with two Ethernet ports (E0 and E1) located on the back of the device shown in [Figure 3](#).

- E0 port: 100/1000/2500BaseT auto-sensing MDI/MDX wired RJ45 network connectivity port
- E1 port: 100/1000BaseT auto-sensing MDI/MDX wired RJ45 network connectivity port

Both ports are compliant with 802.3ab 1000BaseT Gigabit Ethernet standard, while E0 also supports both NBase-T and 802.3bz standards for 2.5Gbps Ethernet. Both ports support 802.3at and 802.3af to accept power from a POE source, such as a PoE midspan injector, or a network controller.

USB Interface

The side of this access point is equipped with a USB-A port that is compatible with cellular modems. When active, this port can supply up to 5W/1A to a connected device. See [Figure 5](#).

Figure 5 Aruba AP-344 (side view)



Push Button

The push button located on the back-right corner of the device can be used to reset the access point to factory default settings or turn off/on the LED display.

- To reset the access point to factory default settings:
 1. Power off the access point.
 2. Press and hold the push button using a small, narrow object, such as a paperclip.
 3. Power-on the access point without releasing the push button. The System Status LED will flash within 5 seconds.
 4. Release the push button.

The system status LED will flash again within 15 seconds indicating that the reset is completed. The access point will now continue to boot with the factory default settings.

- To turn off/on the LED display:

During the normal operation of the access point, press and release the push button using a small, narrow object, such as a paperclip.

Power

Aruba 340 Series access points accept Power over Ethernet (PoE-in) from IEEE 802.3at and 802.3af sources. This can be done by linking either the E0 or E1 port to power sourcing equipment, such as a PoE midspan injector, or network controller providing PoE via Ethernet cable.

If both Ethernet ports are used to draw power from two PoE sources simultaneously, the access point will draw from the more capable power source (prioritizing 802.3at over 802.3af), while continuing to draw a minimal current from the secondary source. In the event that the primary power source fails, the access point will switch to the secondary source for a hitless failover. When both PoE sources are equally capable, the source connected to the E0 port is prioritized.

Alternatively, an AP-AC-48V36C AC-to-DC (sold separately) can be used to power the access point.

If the access point is connected to both DC and PoE sources simultaneously, the device will draw power from the DC source, while continuing to draw a minimal current from the PoE source. In the event that the DC power source fails, the access point will switch to the PoE source for a hitless failover.

The Intelligent Power Monitoring (IPM) feature may also be used to manage the power consumption preferences for this device. When enabled, the user may enable/disable power restrictions for the access point using Aruba's AP management software.

For details about maximum power consumption levels and operational restrictions for power sourcing modes, refer to [Table 3](#).

Table 3 Power Sourcing Modes

Power Source	IPM	Max Power Consumption	Restrictions
DC	n/a	28.8W	No restrictions, all capabilities available
PoE 802.3at	disabled	25.1W	USB disabled*
PoE 802.3at	enabled	25.1W	All capabilities available (features may be disabled with IPM configuration)
PoE 802.3af	disabled	13.5W	USB disabled*, one Ethernet port disabled, both radios operate in 2x2 mode
PoE 802.3af	enabled	13.5W	All capabilities available (features may be disabled with IPM configuration)

* These restriction may be overridden using Aruba's AP management software.

Before You Begin

Refer to the sections below before beginning the installation process.

Pre-Installation Checklist

Before installing your 203R Series access point, be sure that you have the following:

- Cat5E UTP cable with network access installed in the wall box
- DC power cable

One of the following network services:

- Aruba Discovery Protocol (ADP)
- DNS server with an "A" record
- DHCP Server with vendor-specific options



This device is in compliance with governmental requirements, and is designed so that only authorized network administrators can change the settings. For more information about access point configuration, refer to the *ArubaOS Quick Start Guide and ArubaOS User Guide*.

Identifying Specific Installation Locations

This access point should be oriented vertically, with rubber pads facing downward to facilitate maximum antenna gain. Use the access point placement map generated by Aruba RF Plan software application to determine the proper installation location(s). Each location should be as close as possible to the center of the intended coverage area and should be free from obstructions or obvious sources of interference. These RF absorbers/reflectors/interference sources will impact RF propagation and should be accounted for during the planning phase and adjusted for in RF plan.

Identifying Known RF Absorbers/Reflectors/Interference Sources

Identifying known RF absorbers, reflectors, and interference sources while in the field during the installation phase is critical. Make sure that these sources are taken into consideration when you attach an access point to its fixed location.

RF absorbers include:

- Cement/concrete—Old concrete has high levels of water dissipation, which dries out the concrete, allowing for potential RF propagation. New concrete has high levels of water concentration in the concrete, blocking RF signals.
- Natural Items—Fish tanks, water fountains, ponds, and trees
- Brick

RF reflectors include:

- Metal Objects—Metal pans between floors, rebar, fire doors, air conditioning/heating ducts, mesh windows, blinds, chain link fences (depending on aperture size), refrigerators, racks, shelves, and filing cabinets.
- Do not place an access point between two air conditioning/heating ducts. Make sure that access points are placed below ducts to avoid RF disturbances.

RF interference sources include:

- Microwave ovens and other 2.4 or 5 GHz objects (such as cordless phones)
- Cordless headset such as those used in call centers or lunch rooms

Access Point Installation

The 340 Series ships with two ceiling rail adapters for 9/16" and 15/16" ceiling rails. Additional wall mount adapters and ceiling rail adapters for other rail styles are available as accessory kits.



The installer is responsible for securing the access point onto the ceiling tile rail in accordance with the steps below. Failure to properly install this product may result in physical injury and/or damage to property.

1. Pull the necessary cables through a prepared hole in the ceiling tile near where the access point will be placed.
2. Place the adapter against the back of the access point with the adapter at an angle of approximately 30 degrees to the tabs (see [Figure 6](#)).
3. Twist the adapter clockwise until it snaps into place in the tabs (see [Figure 6](#)).

Figure 6 Attaching the Ceiling Rail Adapter

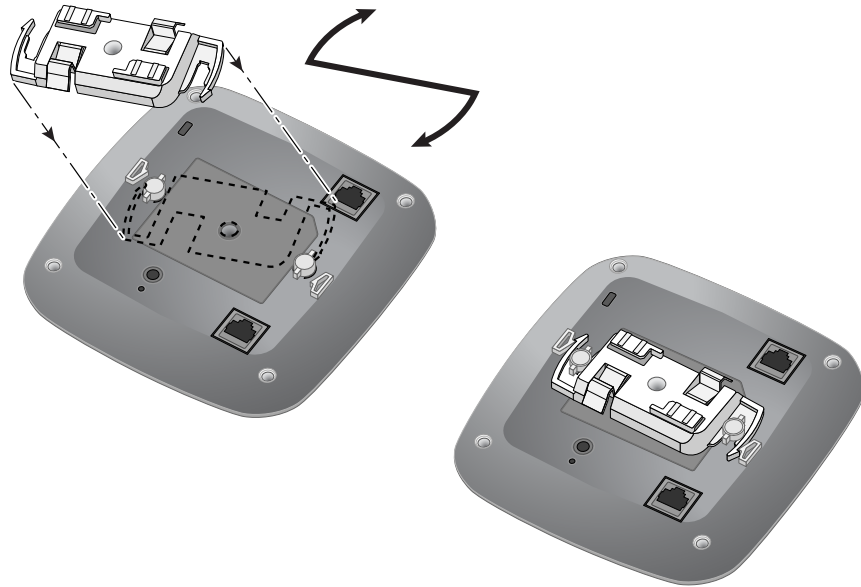

4. If necessary, connect the console cable to the console port on the back of the access point.
5. Hold the access point next to the ceiling tile rail with the ceiling tile rail mounting slots at approximately a 30-degree angle to the ceiling tile rail (see [Figure 7](#)). Make sure that any cable slack is above the ceiling tile.
6. Pushing toward the ceiling tile, rotate the access point clockwise until the device clicks into place on the ceiling tile rail.

Figure 7 Mounting the Access Point

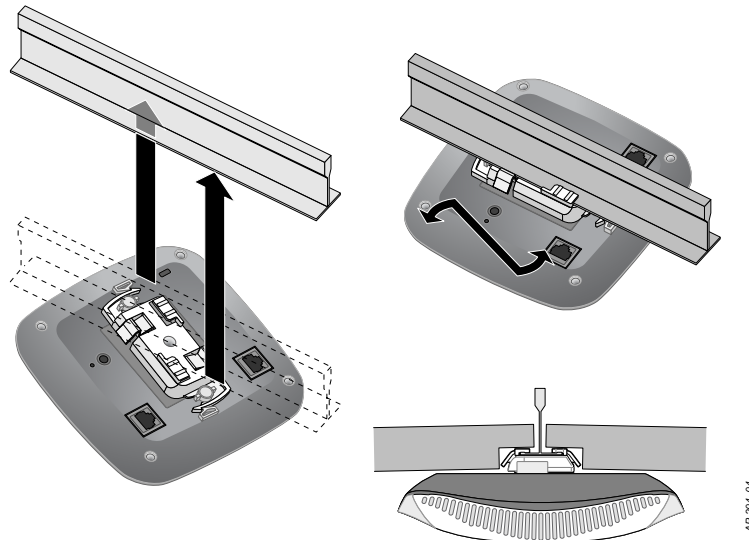

7. For the AP-344, install the external antennas onto the antenna connectors on front of the access point by screwing them clockwise into place. Once attached to the access point, position the antennas as needed.

Software

For instructions on choosing operating modes and initial software configuration, refer to the most current version of the Access Point Software Quick Start Guide.

Verifying Post-Installation Connectivity

The integrated LED on the access point can be used to verify that the access point access point is receiving power and initializing successfully (see [Table 1-4](#)). Refer to the Access Point Software Quick Start Guide for further

details on verifying post-installation network connectivity.

Environmental Specifications

For additional specifications on this product, please refer to the product data sheet at www.arubanetworks.com/safety_addendum.

Environmental

- Operating:
 - Temperature: 0° C to +40° C (+32° F to +104° F)
 - Humidity: 5% to 93% non-condensing
- Storage and transport:
 - Temperature: -40° C to +70° C (-40° F to +158° F)
 - Humidity: 5% to 93% non-condensing

Medical

1. Equipment not suitable for use in the presence of flammable mixtures.
 2. Connect to only IEC 60950-1 or IEC 60601-1 3rd edition certified products and power sources. The end user is responsible for the resulting medical system complies with the requirements of IEC 60601-1 3rd edition.
 3. Wipe with a dry cloth, no additional maintenance required.
 4. No serviceable parts, the unit must be sent back to the manufacturer for repair.
- No modifications are allowed without Aruba approval.

Proper Disposal of Aruba Equipment

Dispose of Aruba products per local regulation. For the most current information about Global Environmental Compliance and Aruba products, see our website at www.arubanetworks.com.

Waste of Electrical and Electronic Equipment

Aruba products at end of life are subject to separate collection and treatment in the EU Member States, Norway, and Switzerland and therefore are marked with the symbol shown at the left (crossed-out wheellie bin). The treatment applied at end of life of these products in these countries shall comply with the applicable national laws of countries implementing Directive 2002/96EC on Waste of Electrical and Electronic Equipment (WEEE).

The expected service life for this device is 10 years. Regulatory Information

The regulatory model names for the 340 Series access points are:

- AP-344: APIN0344
- AP-345: APIN0345



Changes or modifications to this unit not expressly approved by the party responsible for compliance could void the user's authority to operate this equipment.

Toute modification effectuée sur cet équipement sans l'autorisation expresse de la partie responsable de la conformité est susceptible d'annuler son droit d'utilisation.

Regulatory Information

This section contains regulatory information for the following countries:

Brazil

Este equipamento não tem direito à proteção contra interferência prejudicial e não pode causar interferência em sistemas devidamente autorizados.

Canada

User manuals for license-exempt radio apparatus shall contain the following text, or an equivalent notice that shall be displayed in a conspicuous location, either in the user manual or on the device, or both:
This device complies with Industry Canada's license-exempt RSSs. Operation is subject to the following two conditions: (1) This device may not cause interference; and(2) This device must accept any interference, including interference that may cause undesired operation of the device.
Cet appareil numérique de la classe B respecte toutes les exigences du Règlement sur le matériel brouilleur du Canada.

Conformément aux réglementations d'Industrie Canada, cet émetteur-récepteur radio doit être utilisé uniquement avec une antenne dont le type et le gain maximal doivent être approuvés par Industrie Canada. Pour réduire les interférences radio potentielles, le type d'antenne et son gain doivent être choisis de façon à ce que la puissance isotrope rayonnée équivalente (PIRE) ne dépasse pas les valeurs nécessaires à une communication efficace.

Ce périphérique est conforme aux règlements RSS exempts de licence d'Industrie Canada. L'utilisation de ce périphérique est soumise aux deux conditions suivantes : (1) ce périphérique ne doit pas provoquer d'interférences, et (2) ce périphérique doit accepter toute interférence, y compris les interférences susceptibles de provoquer un dysfonctionnement.

China

Aruba products also comply with China environmental declaration requirements and are packaged with the "EFUP10" label shown below.

有毒有害物质声明 Hazardous Materials Declaration

部件名称 (Parts)	有毒有害物质或元素 (Hazardous Substance)					
	铅 (Pb)	汞 (Hg)	镉 (Cd)	六价铬 (Cr ⁶⁺)	多溴联苯 (PBB)	多溴二苯醚 (PBDE)
电路板 (PCA Boards)	×	○	○	○	○	○
机械组件 (Mechanical Sub-Assemblies)	×	○	○	○	○	○

○: 表示该有毒有害物质在该部件所有均质材料中的含量均在 SJ/T11363-2006 标准规定的限量要求以下。
Indicates that the concentration of the hazardous substance in all homogeneous materials in the parts is below the relevant threshold of the SJ/T11363-2006 standard.

×: 表示该有毒有害物质至少在该部件的某一均质材料中的含量超出SJ/T11363-2006标准规定的限量要求。
Indicates that the concentration of the hazardous substance of at least one of all homogeneous materials in the parts is above the relevant threshold of the SJ/T11363-2006 standard.

对销售之日的所售产品, 本表显示, 供应链的电子息产品可能包含这些物质。
This table shows where these substances may be found in the supply chain of electronic information products, as of the date of sale of the enclosed product.

此标志为针对所涉及产品的环保使用期标志。某些零部件会有一个不同的环保使用期 (例如, 电池单元模块) 贴在其产品上。
此环保使用期限只适用于产品是在产品手册中所规定的条件下工作。
The Environment-Friendly Use Period (EFUP) for all enclosed products and their parts are per the symbol shown here. The Environment-Friendly Use Period is valid only when the product is operated under the conditions defined in the product manual.



Europe

The Declaration of Conformity made under RED Directive 2014/53/EU is available for viewing at arubanetworks.com, then navigate to the **Declarations of Conformity > Access Point** folder, then select the document that corresponds to your device's model number as it is indicated on the packaging of this product.

Wireless Channel Restrictions

5150-5250MHz band is limited to indoor only in the following countries; Austria (AT), Belgium (BE), Bulgaria (BG), Croatia (HR), Cyprus (CY), Czech Republic (CZ), Denmark (DK), Estonia (EE), Finland (FI), France (FR), Germany (DE), Greece (GR), Hungary (HU), Iceland (IS), Ireland (IE), Italy (IT), Latvia (LV), Liechtenstein (LI), Lithuania (LT), Luxembourg (LU), Malta (MT), Netherlands (NL),

Norway (NO), Poland (PL), Portugal (PT), Romania (RO), Slovakia (SK), Slovenia (SL), Spain (ES), Sweden (SE), Switzerland (CH), Turkey (TR), United Kingdom (UK).

Frequency Range MHz	Max EIRP
2412-2472	20 dBm
5150-5250	23 dBm
5250-5350	23 dBm
5470-5725	30 dBm
5725-5850	N/A for EU

India

This product complies with RoHS requirements as prescribed by E-Waste (Management & Handling) Rules, governed by the Ministry of Environment & Forests, Government of India.

Japan

ご使用になっている装置にVCCIマークが付いていましたら、次の説明文をお読み下さい。

この装置は、クラスB情報技術装置です。この装置は、家庭環境で使用することを目的としていますが、この装置がラジオやテレビジョン受信機に近接して使用されると、受信障害を引き起こすことがあります。取扱説明書に従って正しい取り扱いをして下さい。

VCCI-B

Korean

B급 기기 (가정용 방송통신기기)	이 기기는 가정용(B급)으로 전자파적합등록을 한 기기로서 주로 가정에서 사용하는 것을 목적으로 하며, 모든 지역에서 사용할 수 있습니다.
-----------------------	--

이 기기는 업무용 환경에서 사용할 목적으로 적합성평가를 받은 기기로서 가정용 환경에서 사용하는 경우 전파간섭의 우려가 있습니다.

사용자 안내문은 "업무용방송통신기자재"에만 해당된다

Mexico

La operación de este equipo está sujeta a las siguientes dos condiciones: (1) es posible que este equipo o dispositivo no cause interferencia perjudicial y (2) este equipo o dispositivo debe aceptar cualquier interferencia, incluyendo la que pueda causar su operación no deseada.

Taiwan

台灣限用物質含有情況標示

單元	限用物質及其化學符號					
	鉛 (Pb)	汞 (Hg)	鎘 (Cd)	六價鉻 (Cr(VI))	多溴聯苯 (PBB)	多溴二苯醚 (PBDE)
傳輸線和網路線	○	○	○	○	○	○
斷路器	-	○	○	○	○	○
冷卻及加熱系統	○	○	○	○	○	○
磁碟控制器	-	○	○	○	○	○
外殼	-	○	○	○	○	○
風扇	○	○	○	○	○	○
液晶顯示器	-	○	○	○	○	○
存取裝置(HDD)	-	○	○	○	○	○
液壓/氣壓系統	○	○	○	○	○	○
鍵盤	○	○	○	○	○	○
影音設備 (CD/DVD/光碟機)	○	○	○	○	○	○
記憶體	○	○	○	○	○	○
滑鼠	○	○	○	○	○	○
其他機械組裝設備	-	○	○	○	○	○
變壓器/電源供應器	-	○	○	○	○	○
印刷電路零組件 (PCAs)	-	○	○	○	○	○
無線網路線	-	○	○	○	○	○

備考1. "○" 係指該項限用物質之百分比含量未超出百分比含量基準值。
備考2. "-" 係指該項限用物質為排除項目。

第十二條 → 經型式認證合格之低功率射頻電機，非經許可，公司、商號或使用者均不得擅自變更頻率、加大功率或變更原設計之特性及功能。

第十四條 → 低功率射頻電機之使用不得影響飛航安全及干擾合法通信；經發現有干擾現象時，應立即停用，並改善至無干擾時方得繼續使用。

前項合法通信，指依電信法規定作業之無線電通信。低功率射頻電機須忍受合法通信或工業、科學及醫療用電波輻射性電機設備之干擾。

Turkey RoHS

Türkiye Cumhuriyeti: EEE Yönetmeliğine Uygundur

Ukraine RoHS

Обладнання відповідає вимогам Технічного регламенту щодо обмеження використання деяких небезпечних речовин в електричному та електронному обладнанні, затвердженого постановою Кабінету Міністрів України від 3 грудня 2008 № 1057

United States

Improper termination of access points installed in the United States configured to a non-US model controller is a violation of the FCC grant of equipment authorization. Any such willful or intentional violation may result in a requirement by the FCC for immediate termination of operation and may be subject to forfeiture (47 CFR 1.80).

The network administrator(s) is/are responsible for ensuring that this device operates in accordance with local/regional laws of the host domain.

Contact Aruba

Main Site	http://www.arubanetworks.com
Support Site	http://www.arubanetworks.com
Airheads Social Forums and Knowledge Base	http://community.arubanetworks.com/
North America Telephone	1-800-943-4526 (toll free) 1-408-754-1200
International Telephone	http://arubanetworks.com/support-services/contact-support/
Software Licensing Site	http://hpe.com/networking/support
End-of-Life Information	http://arubanetworks.com/support-services/end-of-life/
Security Incident Response Team (SIRT)	Site: http://www.arubanetworks.com/support-service/security-bulletins/ Email: sirt@arubanetworks.com

Copyright

© Copyright 2017 Hewlett Packard Enterprise Development LP

Open Source Code

This product includes code licensed under the GNU General Public License, the GNU Lesser General Public License, and/or certain other open source licenses.

A complete machine-readable copy of the source code corresponding to such code is available upon request. This offer is valid to anyone in receipt of this information and shall expire three years following the date of the final distribution of this product version by Hewlett Packard Enterprise Company.

To obtain such source code, send a check or money order in the amount of US \$10.00 to:

Hewlett Packard Enterprise Company
Attn: General Counsel
3000 Hanover Street
Palo Alto, CA 94304
USA

Warranty

This hardware product is protected by an Aruba warranty. For more details visit www.hpe.com/us/en/support.html