User Manual

Contents

Preparing for installation	1
Safety recommendations	1
General safety recommendations	1
Checking the installation site	1
Accessories provided with the AP	2
Installation preparation checklist	2
Installing the AP	4
Mounting the AP on a wall	4
Mounting the AP to a T-rail	7
Mounting the AP on a ceiling	9
Connecting the power supply	10
Connecting the AP to a local power supply	11
Connecting the AP to a PoE power supply	11
Connecting the AP to the network	12
Logging in to the fat AP	13
Logging in through the console port	13
Setting up the configuration environment	13
Setting terminal parameters	14
Logging in through the console port	16
Logging in through Telnet or web	16
Appendix A Chassis views and technical specifications	17
Chassis views	17
Weights and dimensions	18
Power consumption	18
Power specifications	19
AC voltage range	19
Power adapter specifications	19
Storage media and memory specifications	19
Appendix B LEDs	20
Appendix C Built-in antenna	21
Support and other resources	24
Contacting HP	24
Subscription service	24
Related information	24
Documents	24
Websites	24
Conventions	25

Preparing for installation

ⓘ IMPORTANT:

This installation guide shows you how to install and get started using the HP 525 Wireless Dual Radio 802.11ac Access Point JG993A(AM), JG994A(WW), JG995A(JP), JG996A(IL), JG997A(8pack AW), JG998A(8pack WW), hereafter referred to as the HP 525..

Safety recommendations

⚠ WARNING!

- This product is designed for specific application and needs to be installed by someone with RF and related rule knowledge. The general user shall not attempt to install or change the setting.
 - Before installation and operation, read all of the safety instructions in *Compliance and Safety Guide* supplied with your AP.
-

General safety recommendations

To avoid possible bodily injury or equipment damage, read the following safety recommendations before you install an HP 525. The recommendations do not cover every possible hazardous condition.

- Make sure the ground is dry and flat and anti-slip measures are in place.
- Keep the chassis clean and dust-free.
- Do not place the AP in a moist area and avoid liquid surrounding the AP.
- Keep the chassis and installation tools away from walkways.

Checking the installation site

⚠ WARNING!

Please carefully select the installation position and make sure the final output power does not exceed the limit set forth in relevant rules. The violation of the rule could lead to serious federal penalty.

Determine the installation position by observing the following principles:

- To meet regulatory RF exposure requirements, install the device at a location where the radiating antenna can be kept 40 cm (15.75 in) from any person.

- Leave as few obstacles (such as wall) as possible between APs and clients.
- Install APs away from electronic devices (such as microwave ovens) that might generate radio frequency (RF) noise.
- Do not install APs in a place where water seeping, water soaking, and condensing occur. Prevent water or moisture from entering the APs.
- Do not place the device on any metal surface. Place it where there are no obstacles and good signal strength is available.

Accessories provided with the AP

WARNING!

Only use the antennas which have been approved by the applicant. Unapproved antenna(s) may produce unwanted spurious or excessive RF transmitting power, which is prohibited and could be in violation of FCC/IC limits.

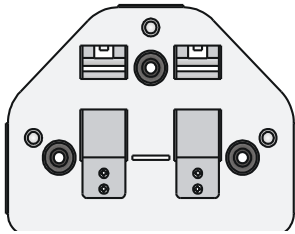

Wall-mounting bracket

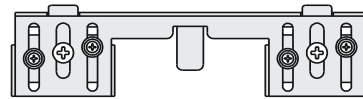

T-rail holder

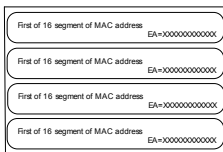

MAC address label

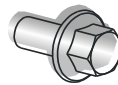

T-rail holder mounting screw

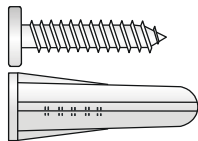

Wall anchor kit



Hex-head bolt, washer, and nut

Antennas, power adapter, and power cable are user-supplied.

Installation preparation checklist

Before you install an AP, verify the following items:

- Connect the power cord and connect the AP to the network. Examine the LED status to make sure the AP can operate correctly. For more information about AP LEDs, see "[Appendix B LEDs](#)."
- Verify that cabling has been completed.

- The device supports 802.3af-compliant PoE. To achieve the best performance, HP recommends that you use a GE connection to the power device.
- Record the MAC address and serial number of the AP (marked on the rear of the AP) for future use.
- If part of the power line is routed outdoors, use a power strip with lightning protection (user supplied) to connect the power cord of the AP to the power line.

Installing the AP

Figure 1 Installation flowchart

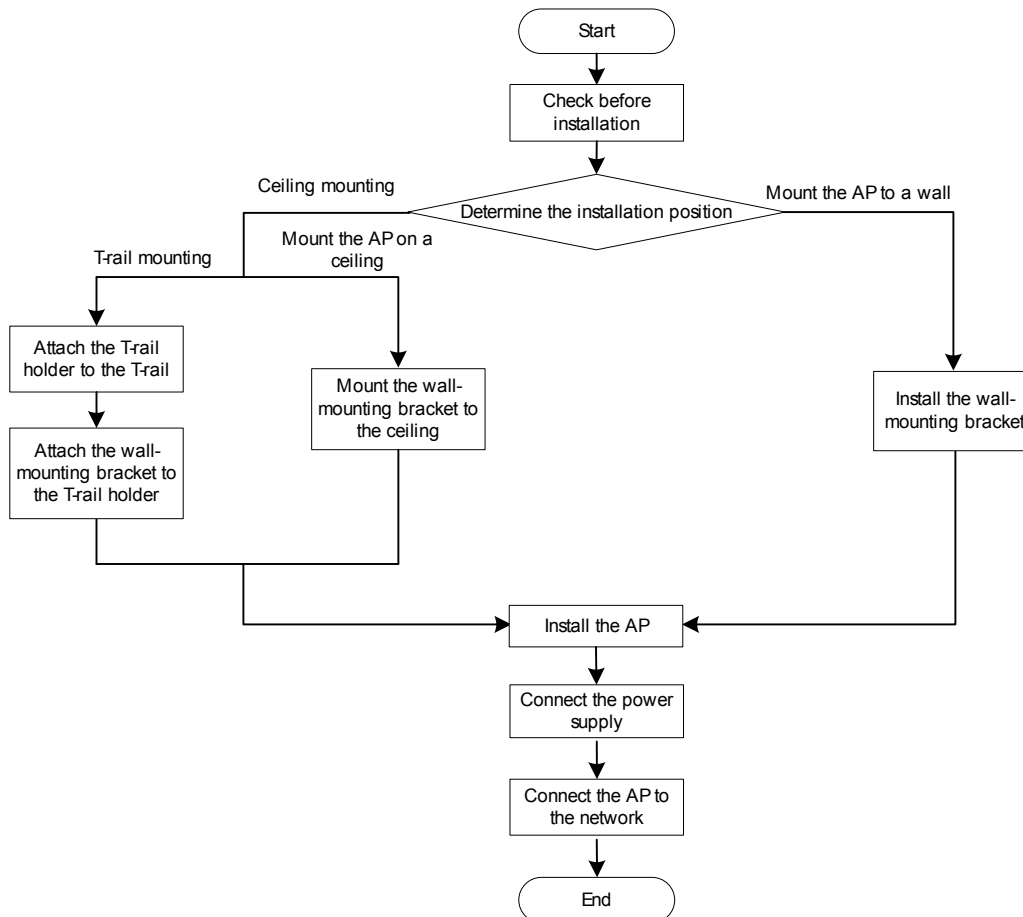

The device can only be used indoors and has built-in antennas. When you install the AP, determine whether external antennas are needed. External antennas are not included with the AP and this document does not include external antenna installation procedures.

Mounting the AP on a wall

! **IMPORTANT:**

Connect the AP to the network by using an Ethernet cable, and then install the AP to the wall-mounting bracket.

To mount the AP on a wall, use the wall-mounting bracket and wall anchor kit that is supplied with the AP as shown in [Figure 2](#).

Figure 2 Screw hole locations and sizes (in mm)

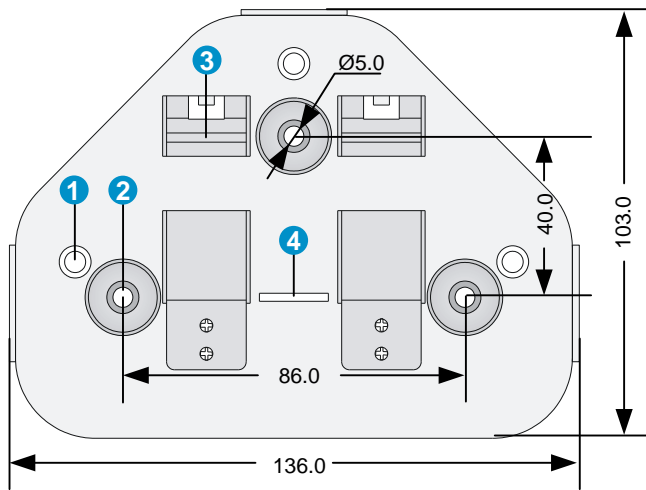

(1) Hook	(2) Mounting hole
(3) Clip	(4) Mounting clip

To mount the AP on a wall:

1. Use the wall-mounting bracket as a template to mark the locations of the mounting holes on the bracket. Drill three 5 mm (0.2 in) diameter holes on the marked mounting hole locations as shown in Figure 3.

Figure 3 Drilling holes in the wall

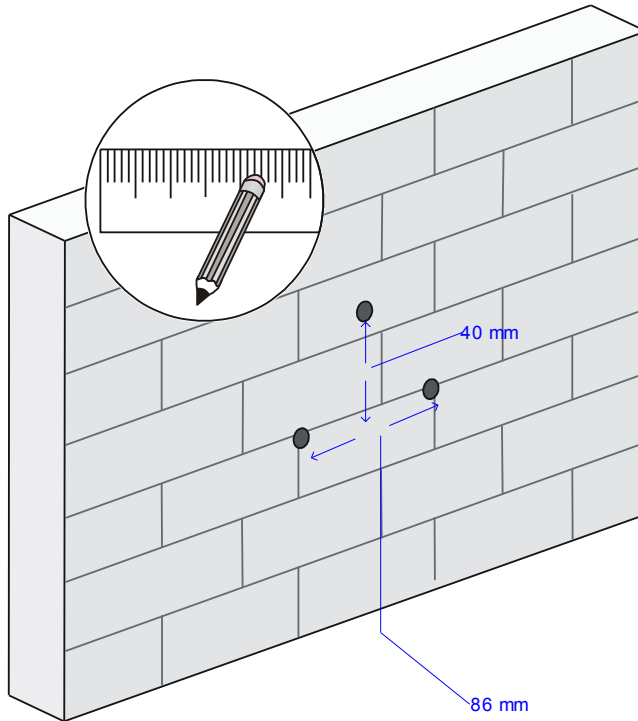

2. Insert a wall anchor into each mounting hole, and tap the wall anchor with a rubber hammer until it is flush with the wall surface as shown in Figure 4.

Figure 4 Inserting a wall anchor

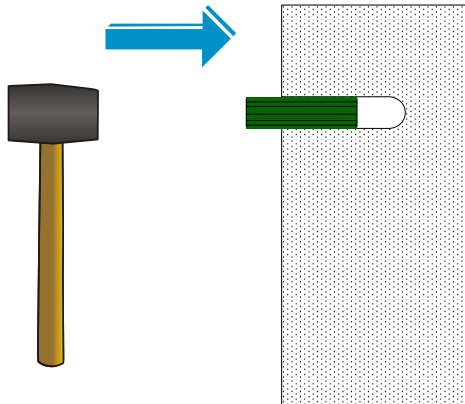

3. Align the holes in the wall-mounting bracket with the anchors and insert screws through the installation holes into the wall anchors as shown in [Figure 5](#).
4. Adjust the position of the wall-mounting bracket and tighten the screws.

Figure 5 Installing the wall-mounting bracket

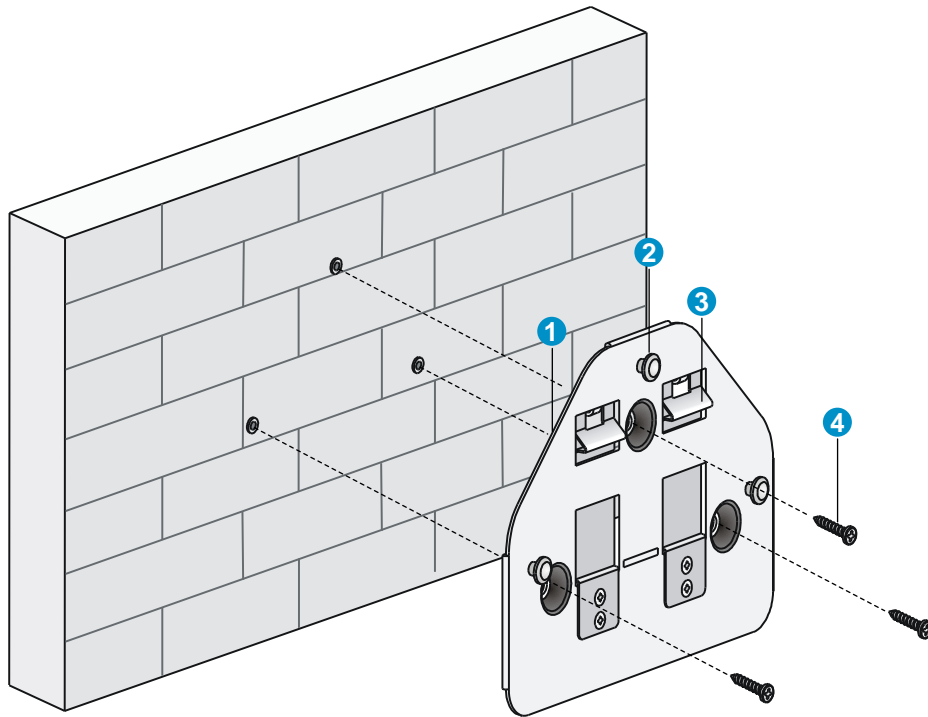

(1) Wall-mounting bracket (2) Hook (3) Clip (4) Screw

5. Connect the AP to the network by using an Ethernet cable.
6. Align the mounting keyhole on the rear of the AP over the hook on the wall-mounting bracket. See [Figure 6](#).
7. Mount the AP on the hook on the wall-mounting bracket. See callout 1 in [Figure 6](#).
8. Pull down the AP until it clicks into place. See callout 2 in [Figure 6](#).

Figure 6 Mounting the AP to the wall mounting bracket

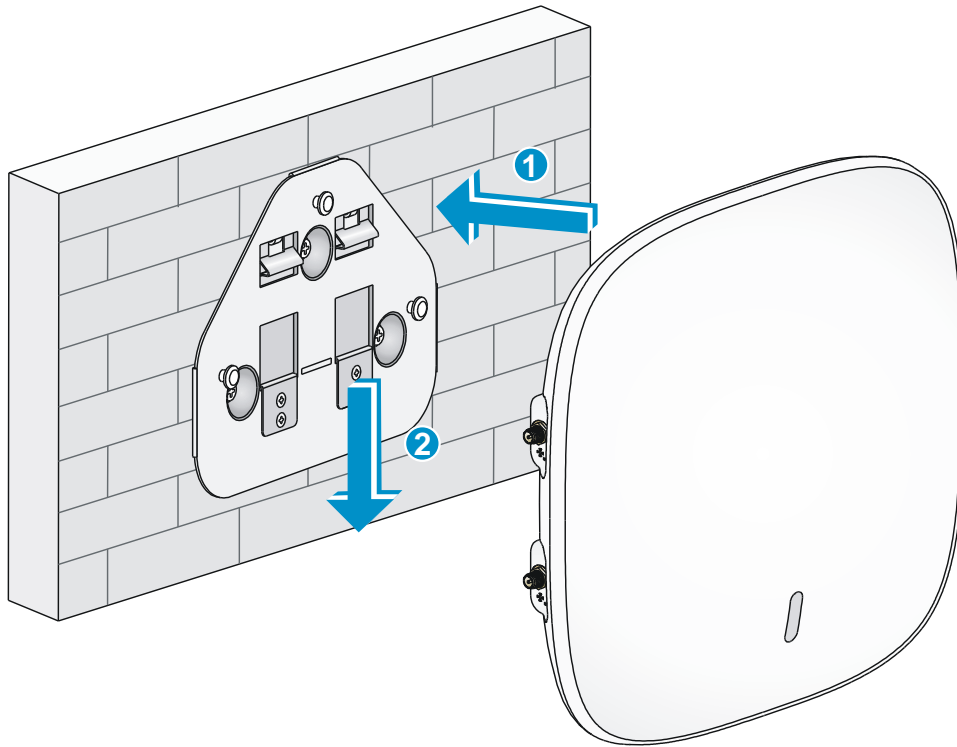

Mounting the AP to a T-rail

! IMPORTANT:

The width of the T-rail must be in the range of 16 mm to 28 mm (0.63 in to 1.10 in).

Figure 7 Screw hole locations and sizes (in mm)

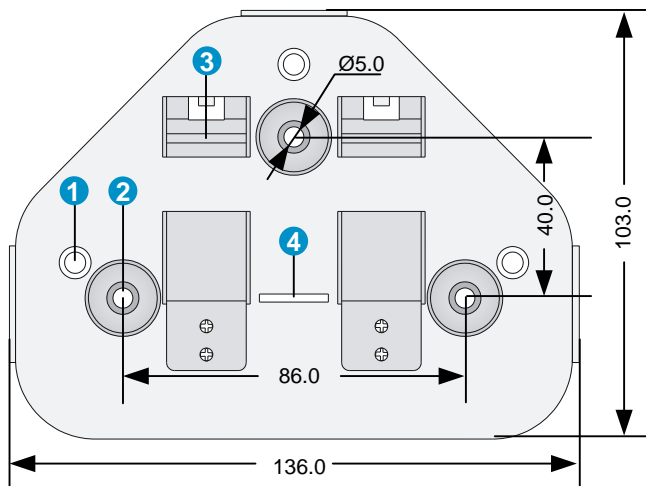

(1) Hook

(2) Mounting hole

(3) Clip

(4) Mounting clip

Figure 8 T-rail holder

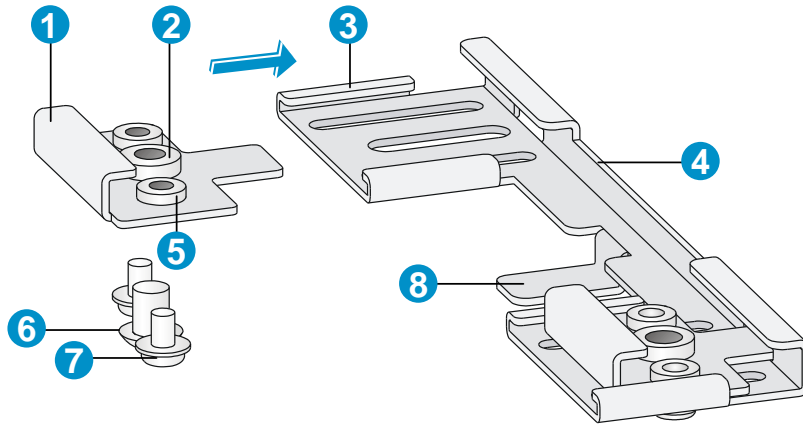

(1) T-rail clip	(2) M4 screw nut	(3) Clip holder
(4) T-rail holder	(5) M3 screw nut	(6) M4 × 5 screw
(7) M3 × 8 screw	(8) Mounting hook	

To mount the AP to a ceiling T-rail:

1. Loosen the two M3 × 8 screws on each clip holder. Do not remove the screws.
2. Adjust the T-rail clips to make the T-rail holder wider than the T-rail. See callout 1 in [Figure 9](#). Then lock the T-rail with the T-rail holder according to the arrow indicated in callout 2 in [Figure 9](#).

Figure 9 Attaching the T-rail holder to the T-rail

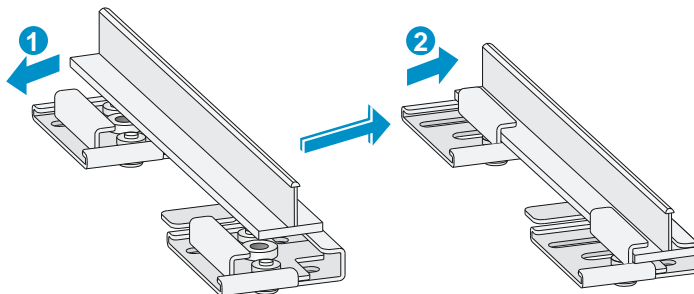

3. Tighten the four M3 × 8 screws on the two clip holders.
4. Verify that the T-rail holder is attached to the T-rail.
5. Hook the mounting clip (see callout 3 in [Figure 10](#)) of the wall-mounting bracket to the mounting hook (see callout 2 in [Figure 10](#)) of the T-rail holder.
6. Insert the two M4 × 5 screws (see callout 1 in [Figure 10](#)) through the two 5 mm (0.20 in) diameter holes on the wall-mounting bracket according to the dashed line shown in [Figure 10](#). Attach the screws to the T-rail holder.
7. Verify that the wall-mounting bracket is attached to the T-rail.
8. Connect the AP to the network by using an Ethernet cable.
9. Install the AP to the wall-mounting bracket. For more information, see "[Mounting the AP on a wall.](#)"

Figure 10 Mounting the AP to the T-rail

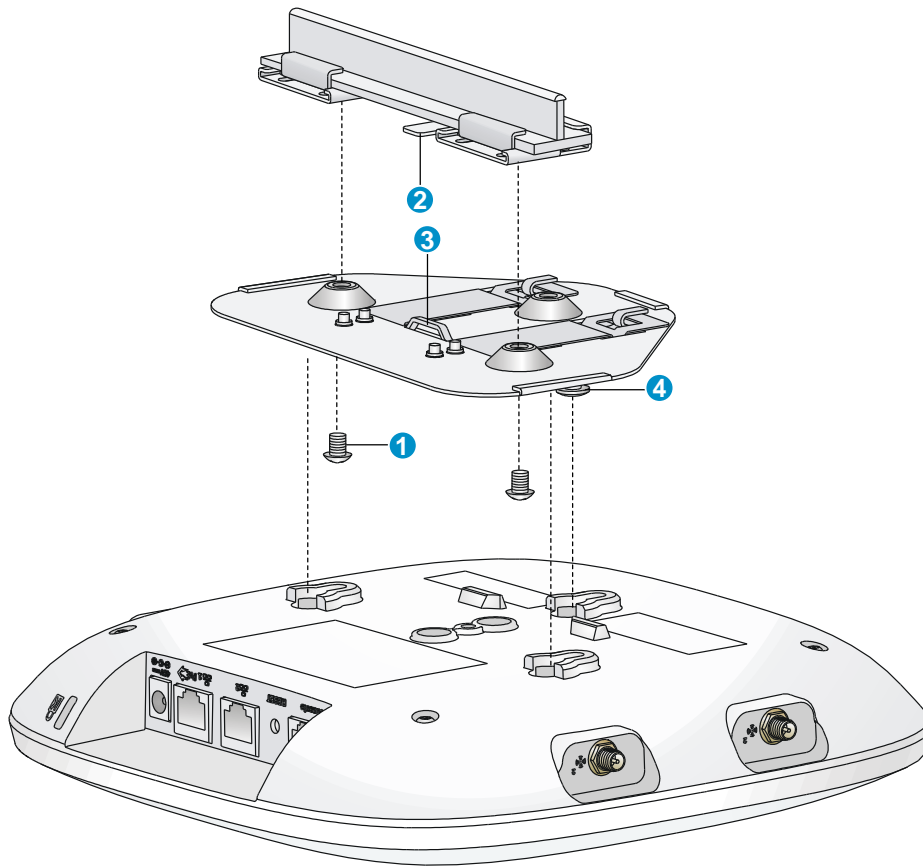

- 1: M4 × 5 screw 2: Mounting hook
3: Mounting clip 4: Hook

(1) M4 × 5 screw (2) Mounting hook (3) Mounting clip (4) Hook

Mounting the AP on a ceiling

△ CAUTION:

- Verify that the AP is secured to the mounting bracket to avoid falloff.
- Do not use this method to mount the AP to a location made of low-intensity materials such as a plaster ceiling. If this installation method is required in such an environment, put a high-intensity plate beneath the ceiling to secure the installation.
- The ceiling tiles must be less than 18 mm (0.71 in) thick, and the ceiling must be able to bear a weight of at least 5 kg (11.02 lb).

The three bolt holes are needed for mounting the AP on a ceiling as shown in [Figure 11](#).

Figure 11 Bolt holes on the wall-mounting bracket (in mm)

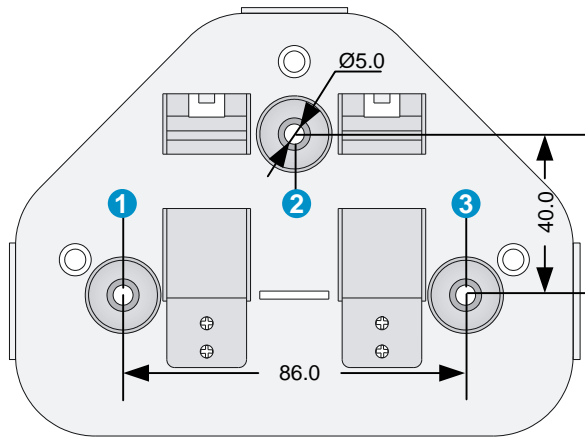

(1) through (3) Bolt holes

To install the AP on a ceiling:

1. Drill three 5.0 mm (0.20 in) diameter holes in the ceiling where you want to mount the AP. The distance between the three holes must be the same as the distance between the three bolt holes on the mounting bracket.
2. Insert the hex-head bolts into the bolt holes on the mounting bracket and the holes in the ceiling. From above the ceiling, fasten the hex nuts to the hex-head bolts to fix the mounting bracket to the ceiling.
3. Connect the AP to the network by using an Ethernet cable.
4. Install the AP to the wall-mounting bracket. For more information, see "[Mounting the AP on a wall.](#)"

Figure 12 Installing the mounting bracket to a ceiling

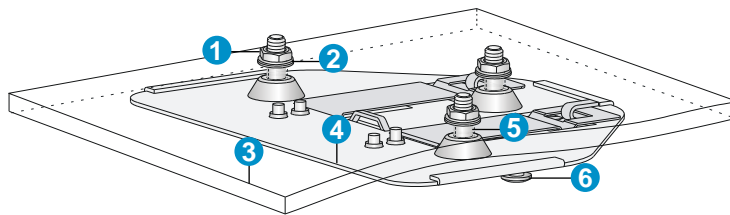

(1) Nut

(2) Washer

(3) Ceiling

(4) Wall-mounting bracket

(5) Hex-head bolt

(6) Hook

Connecting the power supply

The device can be powered by using a local or PoE power supply. You can select either method as needed. Make sure the power supply for either method is well grounded before you power on the AP.

Before you connect the local or PoE power supply, verify that the power supply is steady. You can use a local power source, an uninterruptible power supply (UPS), or a user-supplied power generator to supply power to the AP.

After powering on the AP, examine the AP status LED. For more information about AP LEDs, see [Appendix B LEDs.](#)"

Connecting the AP to a local power supply

The AP is not shipped with a power adapter or power cable.

The device supports both listed AC and DC power adapters marked "LPS" or limited power source. You can connect the power port of the AP to the power source through a power adapter to supply power to the AP as shown in [Figure 13.](#)

Figure 13 Local power supply connection

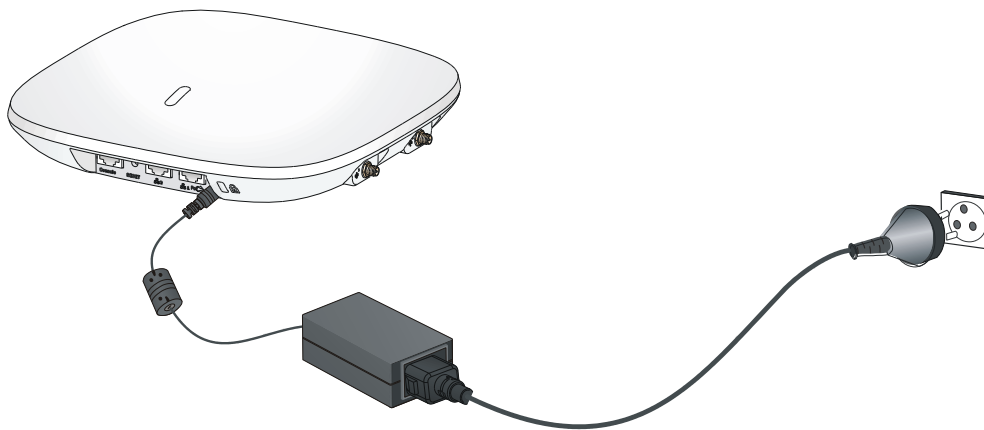

Connecting the AP to a PoE power supply

△ CAUTION:

Identify the marks for the network port and console port to avoid connection mistakes.

When you apply 802.3af PoE power supply, connect one end of the network cable to the network port on the AP, and the other end to an Ethernet port on a PoE-capable device (for example, a PoE-capable Ethernet switch). If the uplink device of the AP is a PoE switch, use an Ethernet cable to directly connect the Ethernet port of the AP to the PoE device as shown in [Figure 14.](#)(indoor used)

Figure 14 PoE connection

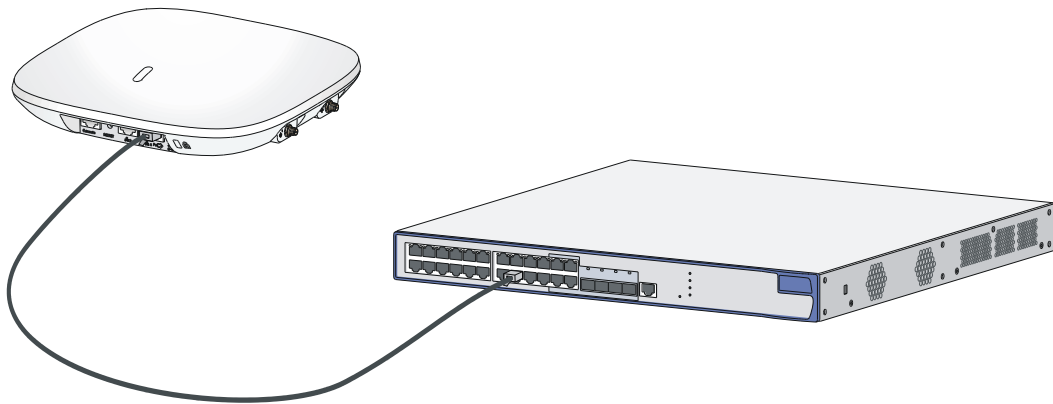

Connecting the AP to the network

APs can access the Internet or metropolitan area network (MAN) through the Ethernet uplink interface. To implement Internet or MAN access, connect the Ethernet port of the AP to an Ethernet port of an Ethernet switch.

When the AP operates as a fit AP, all of its settings are configured on the AC. You can use the **display wlan ap all** command to examine the AP status on the AC. When the AP status is R/M, the AP has been successfully connected to the AC.

```
<AC>display wlan ap all
```

```
Total Number of APs configured          : 1
```

```
Total Number of configured APs connected : 1
```

```
Total Number of auto APs connected      : 0
```

```
AP Profiles
```

```
State : I = Idle,   J = Join, JA = JoinAck,  IL = ImageLoad
```

```
        C = Config, R = Run,  KU = KeyUpdate, KC = KeyCfm
```

AP Name	State	Model	Serial-ID
ap1	R/M	525-WW	CN12GTK123

```
<AC>
```

Logging in to the fat AP

NOTE:

The HP 525 is usually installed on a high position. HP recommends that you log in to the AP to configure related settings before you install the AP.

When the HP 525 operates as a fat AP, you can log in to the AP through the console port, or through Telnet or web to configure the AP, but you must obtain the IP address of the AP first.

- **Logging in through the console port**—Logging in through the console port is the most fundamental login method. To log in through other methods, you must log in through the console port and perform the required configurations.
- **Logging in through Telnet**—You can telnet to the device to remotely manage and maintain it.
- **Logging in through web**—You can log in to the web interface of the device to remotely manage and maintain it.

Logging in through the console port

Prepare the following before you log in through the console port:

- An 8-core shielded console cable, with a crimped RJ-45 connector at one end, and a DB-9 female connector at the other end.
- A configuration terminal—A laptop or PC with a serial port.

Setting up the configuration environment

NOTE:

The serial ports on PCs do not support hot swapping. If the AP has been powered on, connect the console cable to the PC before connecting to the AP, and when you disconnect the cable, first disconnect from the AP.

To connect the console cable:

1. Plug the DB-9 female connector to the serial port of the PC.
2. Connect the RJ-45 connector to the console port of the AP.

Figure 15 Connect the console cable

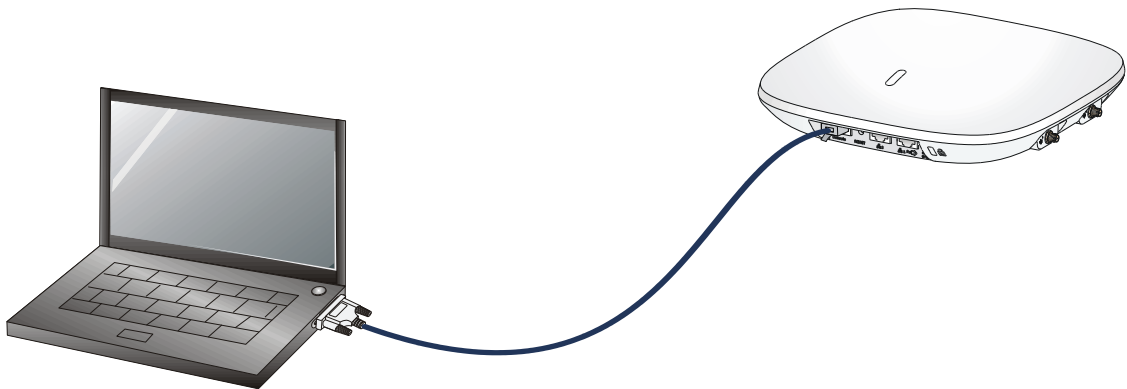

3. Power on the AP.
The AP's startup information will be displayed.

Setting terminal parameters

To set terminal parameters, for example, on a Windows XP HyperTerminal:

1. Select **Start > All Programs > Accessories > Communications > HyperTerminal**.
2. The **Connection Description** dialog box appears.
3. Enter the name of the new connection in the **Name** field and click **OK**.

Figure 16 Connection description

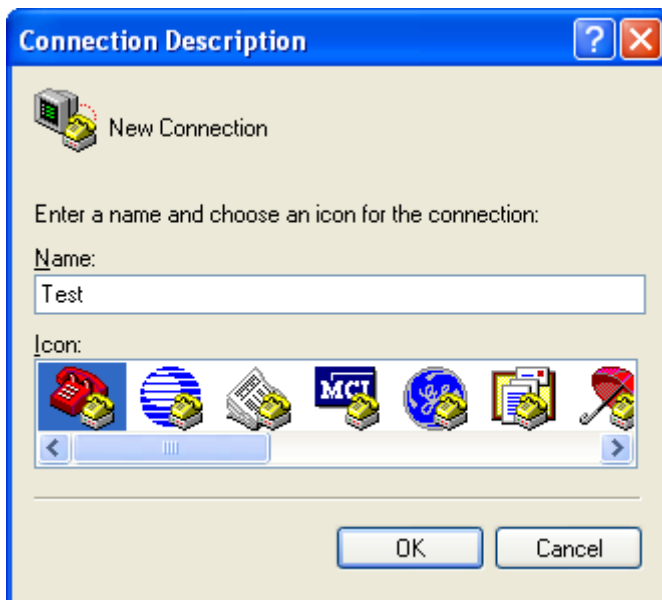

4. Select the serial port to be used from the **Connect using** list, and click **OK**.

Figure 17 Set the serial port used by the HyperTerminal connection

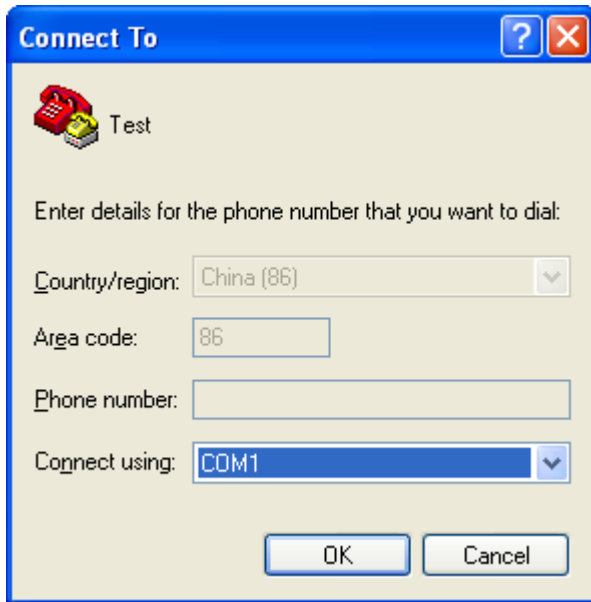

5. Set **Bits per second** to **9600**, **Data bits** to **8**, **Parity** to **None**, **Stop bits** to **1**, and **Flow control** to **None**, and click **OK**.

Figure 18 Set the serial port parameters

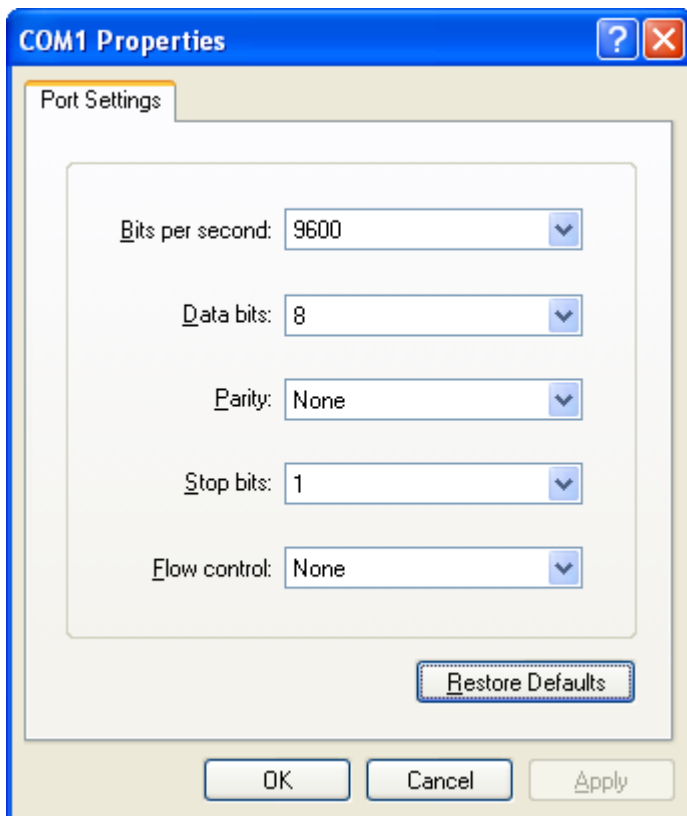

NOTE:

To restore the default settings, click **Restore Defaults**.

The HyperTerminal window appears.

Figure 19 HyperTerminal window

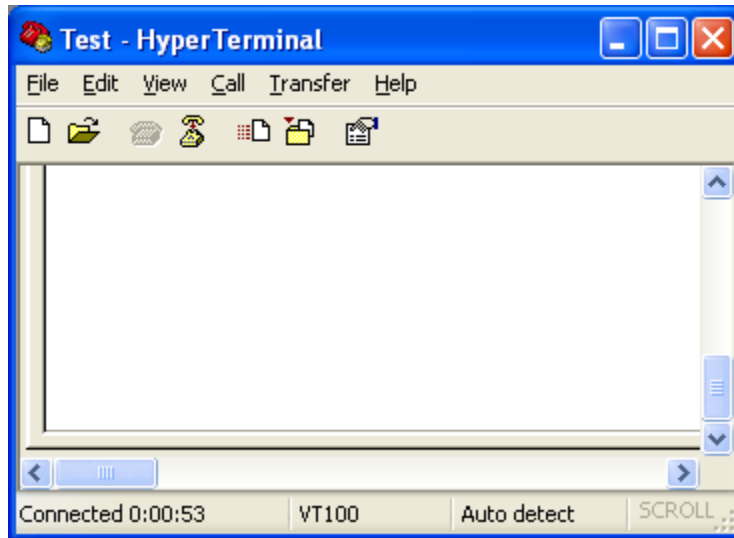

Logging in through the console port

Power on the AP, and you can see the following information:

```
System is starting...
Booting Normal Extend BootWare.
...
System application is starting...
Startup configuration file does not exist.
User interface con0 is available.
```

Press ENTER to get started.

Logging in through Telnet or web

By default, the Telnet and web functions are enabled. You can use the following default settings to log in to the web interface:

- **Username**—admin
- **Password**—password
- **Management IP address of VLAN-interface 1 of the AP**—192.168.0.50, with the subnet mask 255.255.255.0.

If the default IP address is changed, contact the administrator to get the new IP address, or use the **display vlan 1** command to view the IP address after logging in to the AP from the console port.

Appendix A Chassis views and technical specifications

Chassis views

The device provides the following external ports:

- Two 2.4 GHz antenna ports, two 5 GHz antenna ports
- A console port
- Two 10/100/1000 Mbps copper Ethernet ports
- A power supply port

NOTE:

The device also provides a reset button.

Figure 20 HP 525 ports

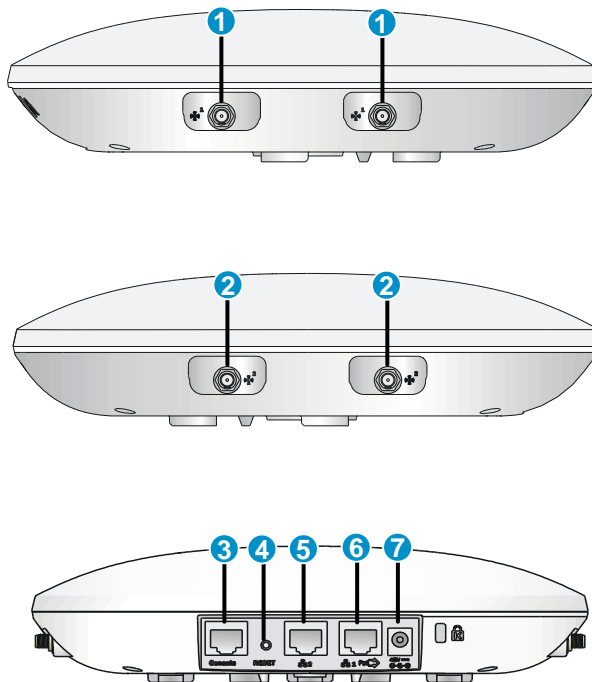

(1) 5G antenna port	(2) 2.4G antenna port	(3) Console port
(4) Reset button	(5) 10/100/1000 Mbps copper Ethernet port 2	(6) 10/100/1000 Mbps copper Ethernet port 1
(7) Local power port		

Table 1 HP 525 port description

Port	Standards and protocols	Description
2.4G antenna port	<ul style="list-style-type: none"> • IEEE802.11b • IEEE802.11g • IEEE802.11n 	The antenna ports are provided for 2.4 GHz single-RF antennas.
5G antenna port	<ul style="list-style-type: none"> • IEEE802.11a • IEEE802.11n • IEEE802.11ac 	The antenna ports are provided for 5 GHz single-RF antennas.
48V DC	N/A	The local power port is used for +48 VDC power supply to the device.
10/100/1000 Mbps copper Ethernet port 1	<ul style="list-style-type: none"> • IEEE802.3 • IEEE802.3u • IEEE802.3af 	10/100/1000 Mbps copper Ethernet port 1 supports PoE .The Ethernet port can serve as an uplink interface to access the Internet or MAN, and as an 802.3af-compliant PoE port at the same time.
10/100/1000 Mbps copper Ethernet port 2	<ul style="list-style-type: none"> • IEEE802.3 • IEEE802.3u 	10/100/1000 Mbps copper Ethernet port 2.The Ethernet port can serve as an uplink interface to access the Internet or MAN.
Console port	RS/EIA-232	The console port is used for configuration and management (for debugging when the AP operates as a fit AP).

Weights and dimensions

Item	Description
Height	45 mm (1.77 in)
Width	220 mm (8.66 in)
Depth	220 mm (8.66 in)
Weight	750g (26.45 oz)

Power consumption

Model	Maximum power consumption
HP 525	12.95 W



Power specifications

AC voltage range

Table 2 AC voltage range

Power supply mode	Voltage range	Frequency
Single-phase three-wire (V)	100 V to 240 V	50 or 60 Hz

Power adapter specifications

Item	Description
Input	100 VAC to 240 VAC
Output	+48V  @ 0.63 A 

Storage media and memory specifications

Item	Description
Storage media	Nor Flash 4 MB
	Nand Flash 128 MB
Memory	DDR2 256 MB

Appendix B LEDs

Table 3 LED description

Mark	Status	Description
	Flashing green at 1 Hz	The AP is booting. NOTE: When the AP operates as a fit AP, it is always in this state before it is registered to an AC.
	Slowly pulsing green	Connections are present on the 2.4 GHz radios.
	Flashing blue at 0.25 Hz	The AP has been booted and has registered to the AC. It is in standby state (no client is associated to the AP).
	Flashing blue at 4 Hz	The AP is upgrading its system software image.
	Slowly pulsing blue	Connections are present on the 5 GHz radios.
	Steady orange	An initialization exception has occurred to the AP.
	Flashing orange at 1 Hz	The AP cannot detect any radio interface.
	Flashing orange at 8 Hz	An Ethernet port or radio interface is operating incorrectly.
	Cycle through two green pulses then two blue pulses	Connections are present on both the 2.4 GHz and 5 GHz radios.

Appendix C Built-in antenna

The HP 525 AP has a built-in dual-band MIMO antenna. Built-in cables connect the MIMO antenna to the 2.4 GHz and 5 GHz antenna ports of the AP.

Table 4 Specifications

Item	Specification
Standard	IEEE 802.11n, 802.11ac and 802.11 a/b/g
Frequency range	<ul style="list-style-type: none"> • 2.4 to 2.49 GHz • 4.9 to 5.9 GHz
Peak gain	<ul style="list-style-type: none"> • 4 dBi @ 2.4 GHz • 5 dBi @ 5.2 GHz
VSWR	2:1
Feed impedance	50 Ω
Power handling	30 dBm
Dimensions	90 x 90 x 14.7 mm (3.54 x 3.54 x 0.58 ft)
Weight	19 g (0.67 oz)
Temperature range	<ul style="list-style-type: none"> • Operating: -40° C to +75° C (-40° F to +167° F) • Storage: -40° C to +85° C (-40° F to +185° F)
Humidity range	0% to 95%, non-condensing

The following figures show the radiation patterns of the antenna.

Figure 21 2.4 GHz radiation pattern in the horizontal plane

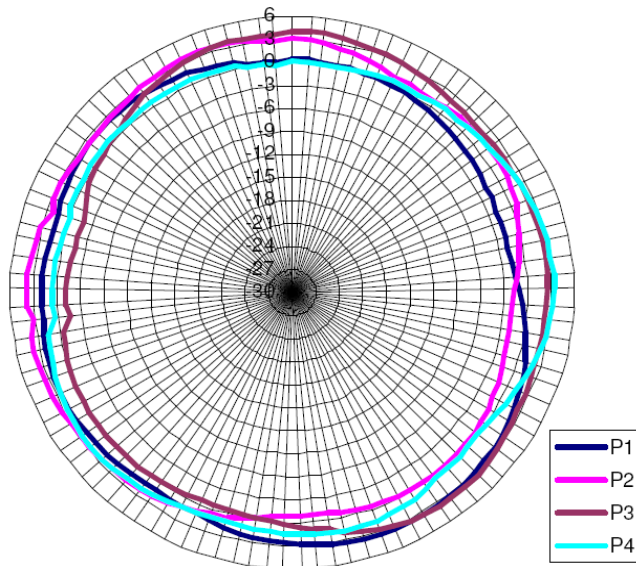

Figure 22 2.4 GHz radiation pattern in the vertical plane

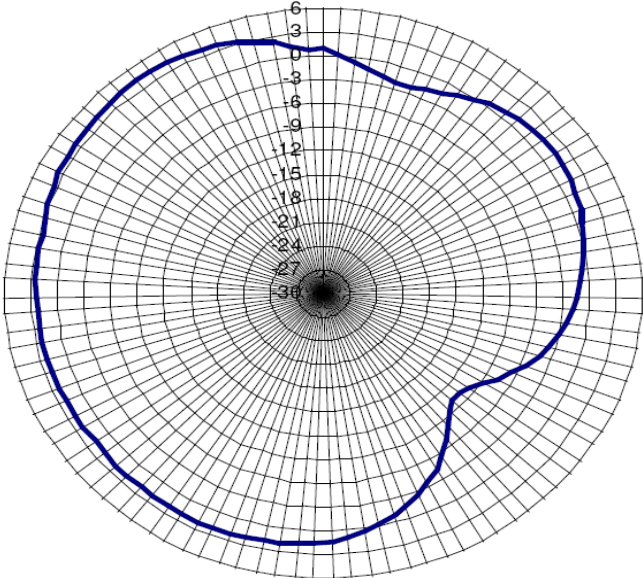

Figure 23 5.2 GHz radiation pattern in the horizontal plane

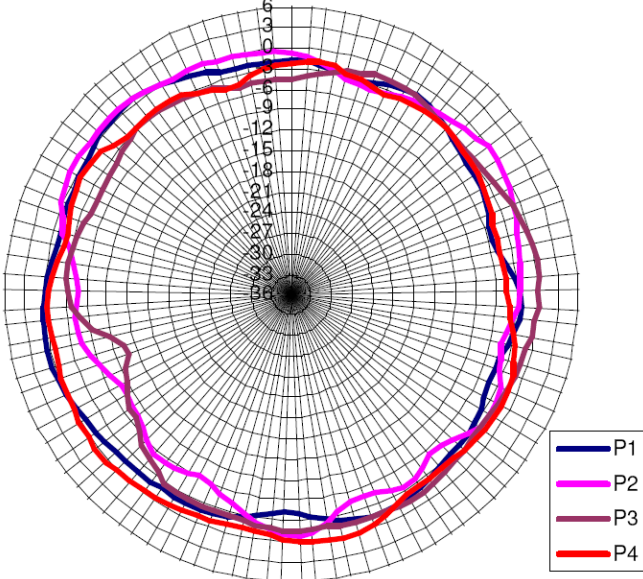
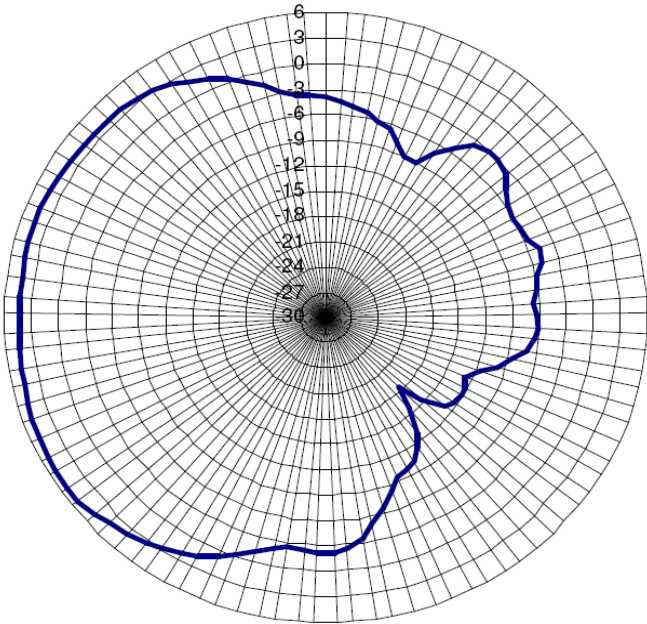

Figure 24 5.2 GHz radiation pattern in the vertical plane



Support and other resources

Contacting HP

For worldwide technical support information, see the HP support website:

<http://www.hp.com/support>

Before contacting HP, collect the following information:

- Product model names and numbers
- Technical support registration number (if applicable)
- Product serial numbers
- Error messages
- Operating system type and revision level
- Detailed questions

Subscription service

HP recommends that you register your product at the Subscriber's Choice for Business website:

<http://www.hp.com/go/wwalerts>

After registering, you will receive email notification of product enhancements, new driver versions, firmware updates, and other product resources.

Related information

Documents

To find related documents, browse to the Manuals page of the HP Business Support Center website:

<http://www.hp.com/support/manuals>

- For related documentation, navigate to the Networking section, and select a networking category.
- For a complete list of acronyms and their definitions, see *HP FlexNetwork Technology Acronyms*.

Websites

- HP.com <http://www.hp.com>
- HP Networking <http://www.hp.com/go/networking>
- HP manuals <http://www.hp.com/support/manuals>
- HP download drivers and software <http://www.hp.com/support/downloads>

- HP software depot <http://www.software.hp.com>
- HP Education <http://www.hp.com/learn>

Conventions

This section describes the conventions used in this documentation set.





Command conventions

Convention	Description
Boldface	Bold text represents commands and keywords that you enter literally as shown.
<i>Italic</i>	<i>Italic</i> text represents arguments that you replace with actual values.
[]	Square brackets enclose syntax choices (keywords or arguments) that are optional.
{ x y ... }	Braces enclose a set of required syntax choices separated by vertical bars, from which you select one.
[x y ...]	Square brackets enclose a set of optional syntax choices separated by vertical bars, from which you select one or none.
{ x y ... } *	Asterisk-marked braces enclose a set of required syntax choices separated by vertical bars, from which you select at least one.
[x y ...] *	Asterisk-marked square brackets enclose optional syntax choices separated by vertical bars, from which you select one choice, multiple choices, or none.
&<1-n>	The argument or keyword and argument combination before the ampersand (&) sign can be entered 1 to n times.
#	A line that starts with a pound (#) sign is comments.





GUI conventions

Convention	Description
Boldface	Window names, button names, field names, and menu items are in bold text. For example, the New User window appears; click OK .
>	Multi-level menus are separated by angle brackets. For example, File > Create > Folder .

Symbols

Convention	Description
 WARNING	An alert that calls attention to important information that if not understood or followed can result in personal injury.
 CAUTION	An alert that calls attention to important information that if not understood or followed can result in data loss, data corruption, or damage to hardware or software.
 IMPORTANT	An alert that calls attention to essential information.
NOTE	An alert that contains additional or supplementary information.
 TIP	An alert that provides helpful information.

Network topology icons

	Represents a generic network device, such as a router, switch, or firewall.
	Represents a routing-capable device, such as a router or Layer 3 switch.
	Represents a generic switch, such as a Layer 2 or Layer 3 switch, or a router that supports Layer 2 forwarding and other Layer 2 features.
	Represents an access controller, a unified wired-WLAN module, or the switching engine on a unified wired-WLAN switch.
	Represents an access point.

Port numbering in examples

The port numbers in this document are for illustration only and might be unavailable on your device.

Appendix D External Antenna

HP MIMO S2451DBTH33RSM
2x2 Dual Bands MIMO Antenna
2.4-2.5GHz; 4.9-5.875GHz
HP Part No: JG696A



Gain & Efficiency Summary – Low Band

L1 Before

Frequency (MHz)	3D		Azimuth			Elevation 0°		Elevation 90°	
	Efficiency	Max Gain	Max Gain	Average Gain	Ripple	Max Gain	Average Gain	Max Gain	Average Gain
2400	76%	3.67	1.67	-0.63	7.16	1.14	-2.15	1.03	-3.30
2410	77%	3.38	1.28	-0.61	5.50	1.65	-1.79	0.30	-3.17
2420	79%	3.09	1.19	-0.46	4.99	1.93	-1.47	0.76	-3.05
2430	80%	2.79	1.07	-0.39	4.41	1.95	-1.45	1.06	-3.07
2440	79%	2.93	1.06	-0.31	3.88	1.78	-1.65	1.08	-3.18
2450	78%	3.48	1.37	-0.27	4.13	1.43	-2.22	1.03	-3.21
2460	78%	3.96	1.73	-0.22	4.65	0.55	-2.80	0.89	-3.13
2470	78%	4.12	1.95	-0.16	4.73	-0.06	-2.95	0.65	-3.14
2480	77%	3.98	1.87	-0.25	5.15	-0.47	-2.93	1.36	-2.98
2490	77%	3.64	1.69	-0.42	5.26	0.11	-2.62	1.54	-2.80
2500	76%	3.25	1.45	-0.63	6.14	0.80	-2.20	1.42	-2.65

L1 After

Frequency (MHz)	3D		Azimuth			Elevation 0°		Elevation 90°	
	Efficiency	Max Gain	Max Gain	Average Gain	Ripple	Max Gain	Average Gain	Max Gain	Average Gain
2400	76%	3.20	1.45	-0.69	4.24	1.78	-2.15	-0.20	-3.21
2410	76%	3.15	1.37	-0.69	4.12	2.06	-1.93	0.12	-3.10
2420	79%	3.08	1.24	-0.60	3.54	2.21	-1.64	0.60	-2.92
2430	79%	2.81	0.88	-0.60	3.43	2.12	-1.55	0.89	-2.92
2440	78%	2.58	0.59	-0.57	3.31	1.90	-1.58	0.99	-3.00
2450	77%	2.89	0.79	-0.52	3.18	1.44	-1.86	1.13	-2.98
2460	78%	3.17	1.20	-0.47	3.53	0.87	-2.20	1.23	-3.00
2470	77%	3.10	1.41	-0.49	4.11	1.23	-2.31	0.86	-3.03
2480	77%	3.24	1.45	-0.53	4.51	1.57	-2.34	0.62	-3.02
2490	76%	3.31	1.48	-0.57	4.67	1.92	-2.25	0.57	-2.98
2500	76%	3.32	1.41	-0.65	4.47	2.26	-2.04	0.60	-2.95

Gain & Efficiency Summary – Low Band

L2 Before

Frequency (MHz)	3D		Azimuth			Elevation 0°		Elevation 90°	
	Efficiency	Max Gain	Max Gain	Average Gain	Ripple	Max Gain	Average Gain	Max Gain	Average Gain
2400	76%	2.78	1.29	-0.61	6.43	2.29	-2.17	1.79	-1.97
2410	76%	2.61	1.05	-0.67	5.19	2.14	-2.32	1.92	-1.84
2420	79%	2.60	0.82	-0.52	3.60	1.96	-2.27	1.96	-1.75
2430	79%	2.37	0.85	-0.43	3.49	1.61	-2.21	1.82	-1.87
2440	80%	2.52	0.90	-0.27	3.47	1.40	-1.97	1.55	-2.06
2450	80%	3.05	1.60	-0.16	3.82	2.00	-1.65	1.32	-2.24
2460	80%	3.47	1.87	-0.18	3.98	1.83	-1.53	1.79	-2.16
2470	80%	3.51	1.89	-0.14	4.57	2.09	-1.42	1.75	-2.19
2480	78%	3.43	1.68	-0.30	5.24	2.36	-1.61	2.04	-2.06
2490	77%	3.30	1.39	-0.51	6.29	2.49	-1.88	2.35	-1.89
2500	77%	3.05	1.32	-0.72	6.69	2.52	-2.09	2.46	-1.78

L2 After

Frequency (MHz)	3D		Azimuth			Elevation 0°		Elevation 90°	
	Efficiency	Max Gain	Max Gain	Average Gain	Ripple	Max Gain	Average Gain	Max Gain	Average Gain
2400	77%	3.68	1.60	-0.59	4.61	0.70	-2.21	-0.06	-2.99
2410	77%	3.30	1.28	-0.70	4.17	0.73	-2.01	0.58	-2.93
2420	78%	2.91	0.92	-0.59	3.75	1.38	-1.88	1.03	-2.81
2430	79%	2.42	1.30	-0.52	3.65	1.72	-1.99	1.03	-2.80
2440	80%	2.40	1.61	-0.43	3.87	1.83	-2.06	0.81	-2.80
2450	80%	2.91	1.76	-0.42	4.53	1.34	-2.33	0.34	-2.85
2460	80%	3.41	1.78	-0.51	5.35	0.67	-2.52	0.37	-2.84
2470	79%	3.65	1.55	-0.54	5.23	0.39	-2.49	0.34	-2.87
2480	78%	3.78	1.20	-0.64	5.06	0.31	-2.49	0.59	-2.83
2490	77%	3.83	1.23	-0.75	5.15	0.51	-2.40	0.89	-2.80
2500	77%	3.73	1.23	-0.86	5.13	0.72	-2.23	1.13	-2.77

Gain & Efficiency Summary – High Band

H1 Before

Frequency (MHz)	3D		Azimuth			Elevation 0°		Elevation 90°	
	Efficiency	Max Gain	Max Gain	Average Gain	Ripple	Max Gain	Average Gain	Max Gain	Average Gain
4900	53%	4.69	0.28	-2.89	7.74	-0.11	-5.00	4.63	-1.16
5150	53%	5.07	-0.22	-3.12	10.94	-1.12	-5.06	5.01	-1.17
5350	56%	5.65	0.40	-2.93	13.96	0.38	-4.72	5.61	-1.28
5470	55%	5.47	0.61	-2.97	18.04	0.59	-4.80	5.46	-1.64
5725	59%	5.45	1.90	-2.44	19.70	0.54	-4.76	5.45	-1.88
5825	60%	5.32	2.04	-2.33	20.23	0.52	-5.00	5.32	-1.98
5875	57%	5.33	1.53	-2.66	24.27	-0.85	-5.56	5.31	-2.28

H1 After

Frequency (MHz)	3D		Azimuth			Elevation 0°		Elevation 90°	
	Efficiency	Max Gain	Max Gain	Average Gain	Ripple	Max Gain	Average Gain	Max Gain	Average Gain
4900	55%	4.42	0.54	-2.64	7.87	0.72	-4.27	4.02	-1.58
5150	53%	4.31	0.32	-3.08	10.07	1.68	-4.62	3.81	-1.78
5350	56%	4.29	0.98	-2.81	11.67	2.33	-4.70	4.10	-1.81
5470	52%	3.98	0.38	-3.07	11.83	1.76	-5.26	3.75	-2.28
5725	54%	4.44	1.25	-2.77	15.50	-0.02	-5.42	3.54	-2.59
5825	55%	4.61	1.84	-2.78	16.31	-0.74	-5.59	3.33	-2.56
5875	51%	4.05	1.24	-3.26	14.65	-0.95	-6.32	3.11	-2.86

Gain & Efficiency Summary – High Band

H2 Before

Frequency (MHz)	3D		Azimuth			Elevation 0°		Elevation 90°	
	Efficiency	Max Gain	Max Gain	Average Gain	Ripple	Max Gain	Average Gain	Max Gain	Average Gain
4900	67%	6.06	0.82	-1.94	6.66	2.16	-3.24	5.71	-0.27
5150	64%	6.21	0.51	-2.11	11.08	0.71	-4.74	5.84	-0.44
5350	64%	6.13	0.93	-2.09	15.29	-0.47	-5.73	5.89	-0.72
5470	64%	5.86	0.83	-2.22	16.95	-0.88	-5.78	5.68	-0.90
5725	64%	5.19	1.50	-2.24	20.02	0.56	-4.73	5.15	-1.45
5825	58%	4.73	1.10	-2.70	15.91	0.39	-4.90	4.64	-2.08
5875	60%	4.76	1.01	-2.50	14.23	0.23	-4.66	4.49	-2.15

H2 After

Frequency (MHz)	3D		Azimuth			Elevation 0°		Elevation 90°	
	Efficiency	Max Gain	Max Gain	Average Gain	Ripple	Max Gain	Average Gain	Max Gain	Average Gain
4900	66%	5.26	1.22	-1.86	6.78	0.89	-3.65	4.93	-0.71
5150	63%	5.69	0.45	-2.17	8.96	1.87	-4.22	5.26	-0.77
5350	64%	5.45	0.32	-2.17	10.44	1.67	-4.91	5.15	-1.07
5470	63%	5.30	0.55	-2.33	12.31	1.07	-5.23	4.96	-1.35
5725	62%	5.36	1.58	-2.45	11.94	-0.50	-5.09	4.20	-1.70
5825	57%	5.15	1.15	-2.84	13.78	-1.06	-5.51	3.78	-2.10
5875	59%	4.89	1.51	-2.66	14.86	-0.94	-5.45	3.94	-2.14

Radiation Pattern at 2400 MHz – Ant L1

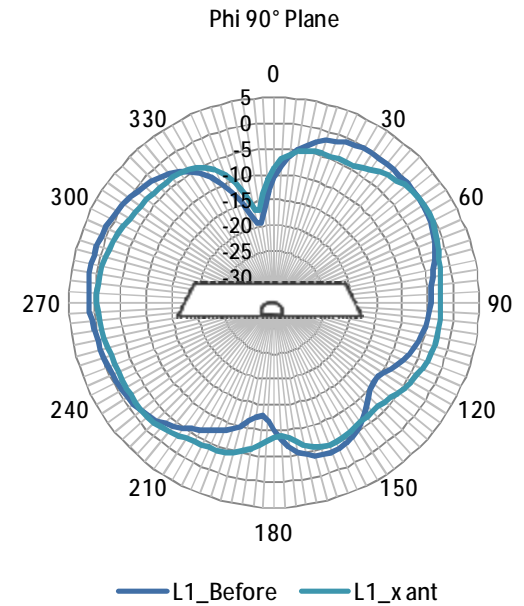
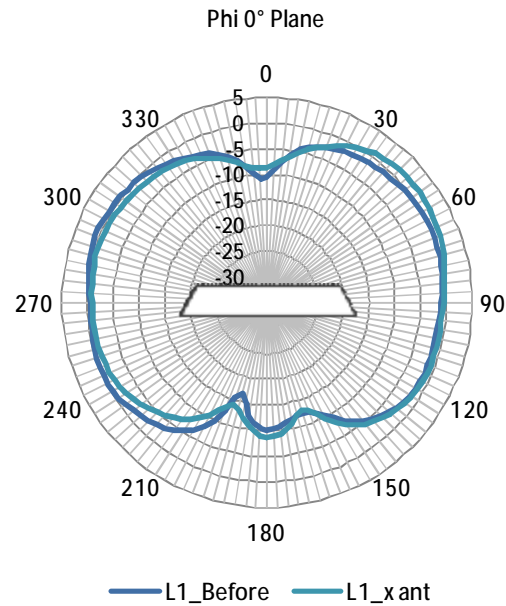
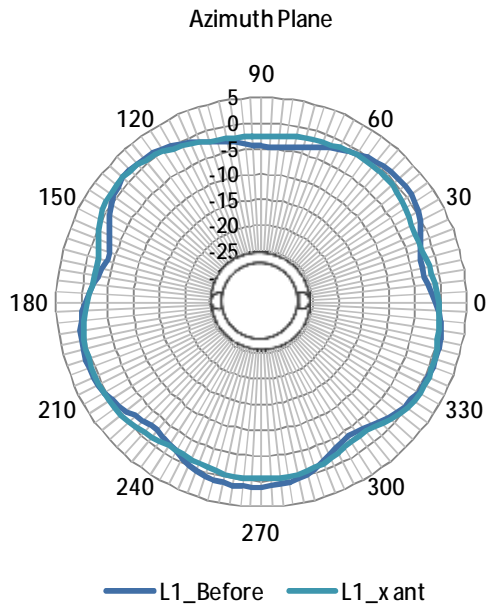

Radiation Pattern at 2450 MHz – Ant L1

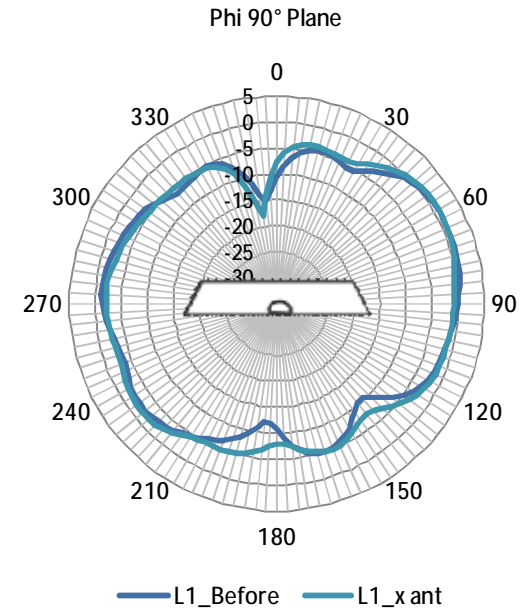
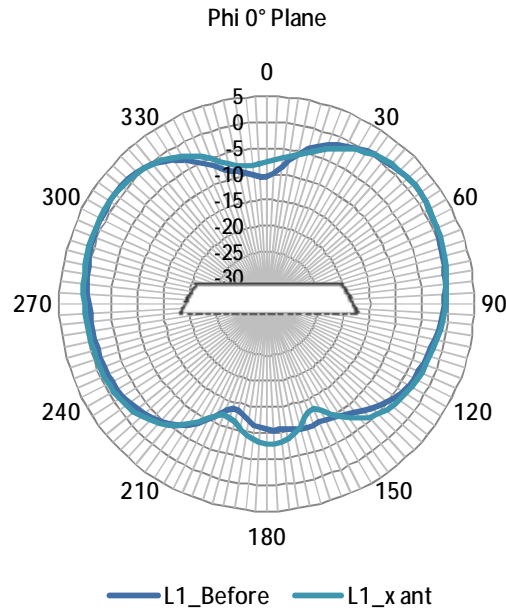
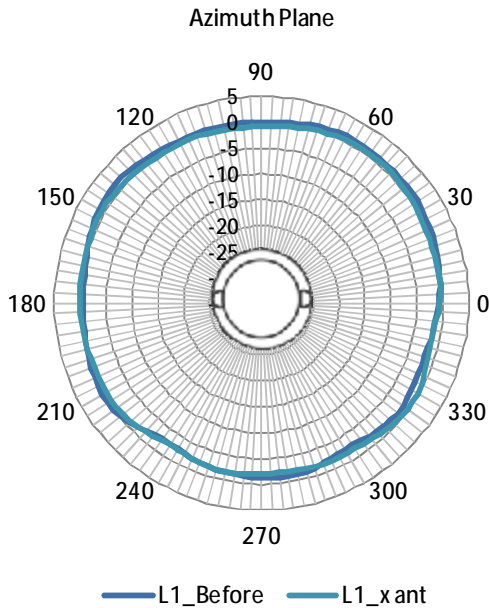

Radiation Pattern at 2500 MHz – Ant L1

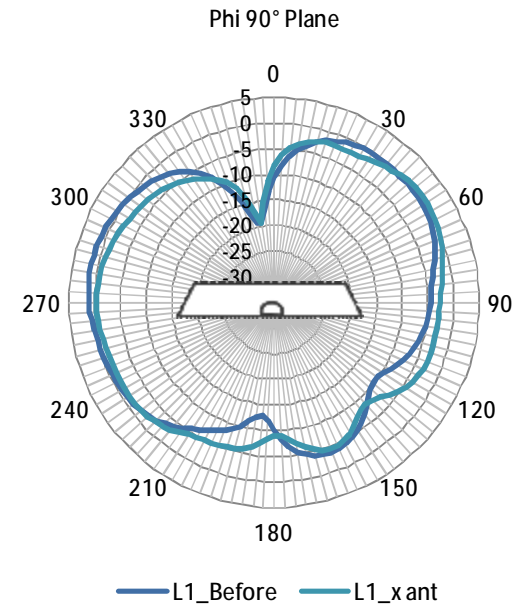
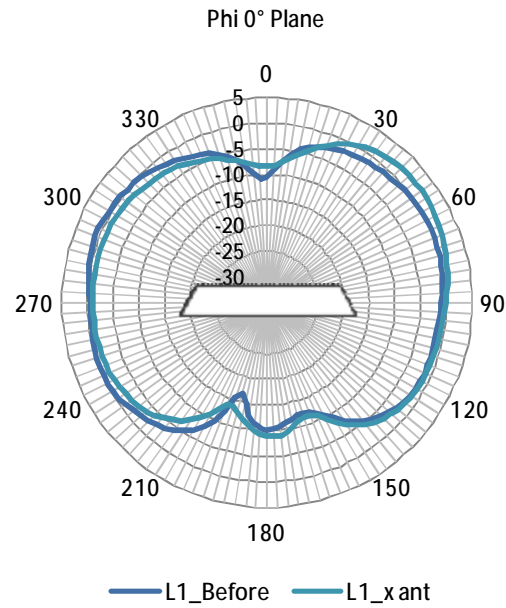
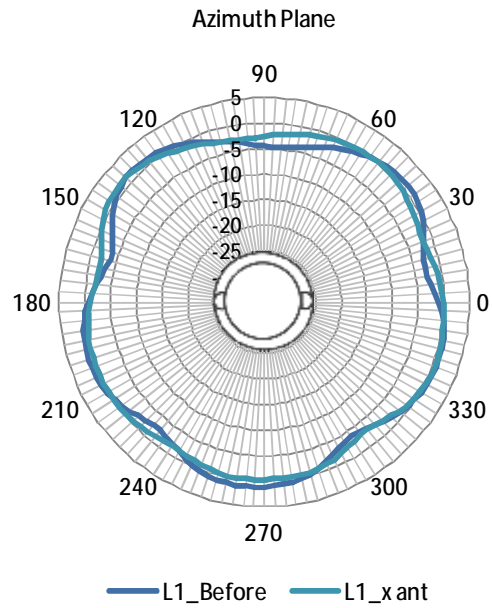

Radiation Pattern at 2400 MHz – Ant L2

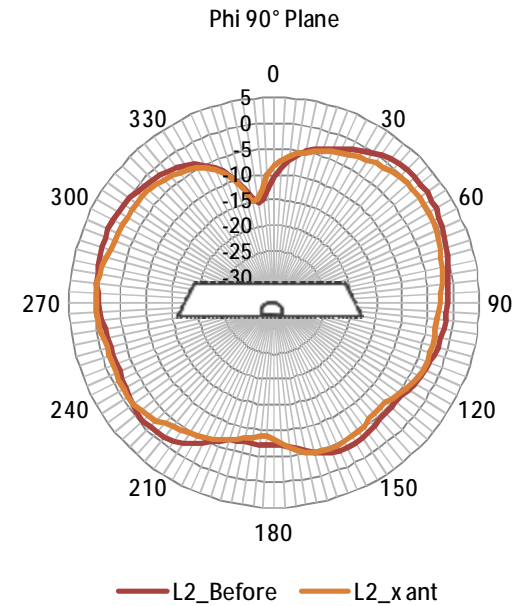
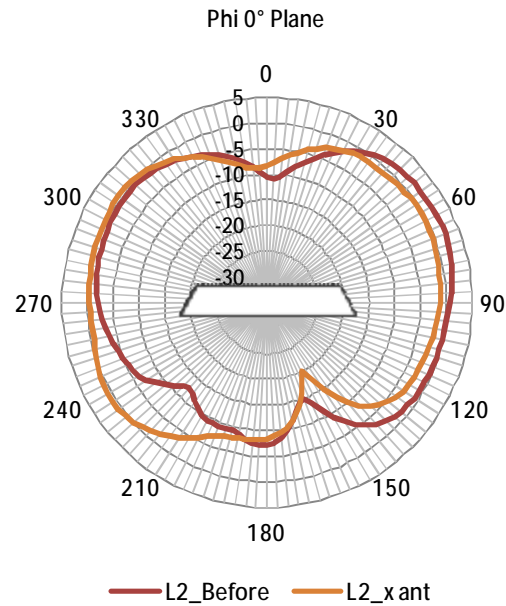
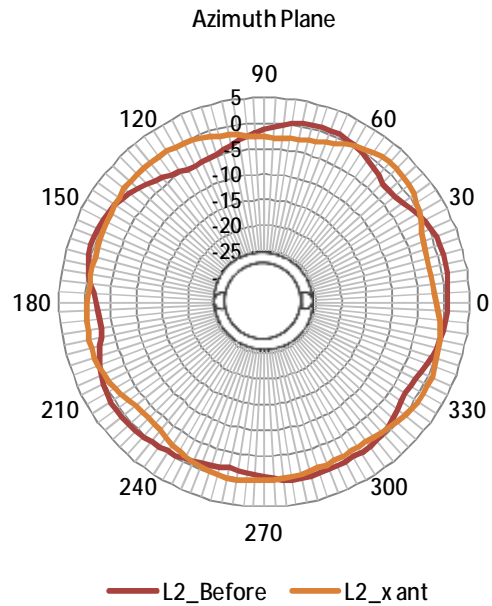

Radiation Pattern at 2450 MHz – Ant L2

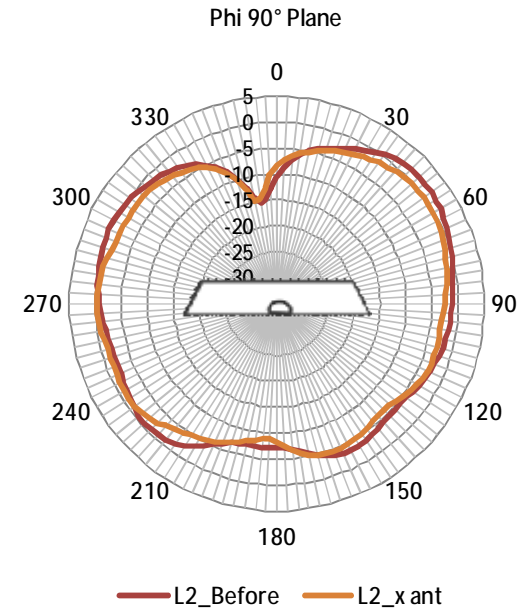
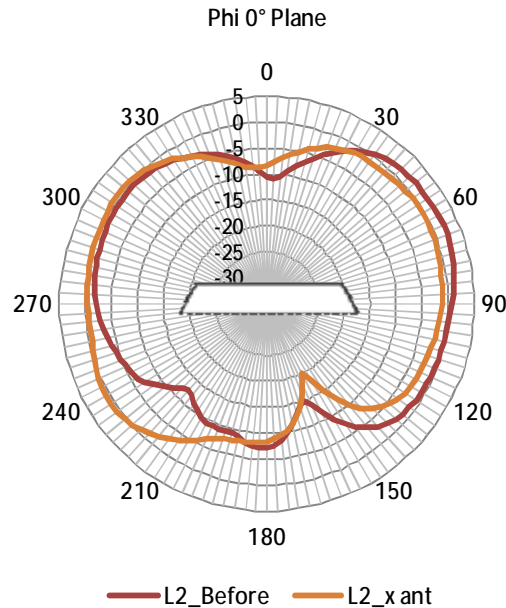
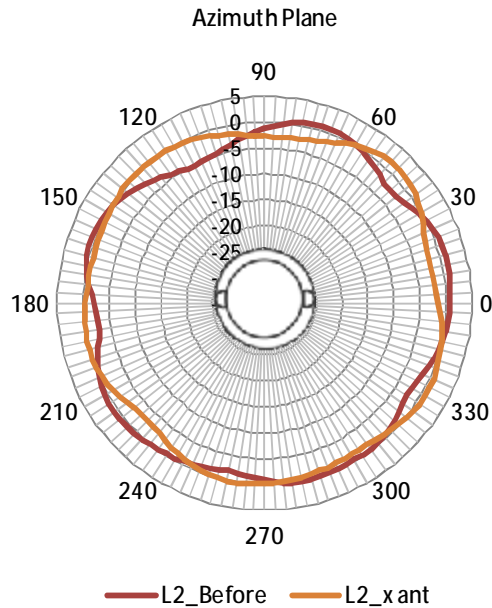

Radiation Pattern at 2500 MHz – Ant L2

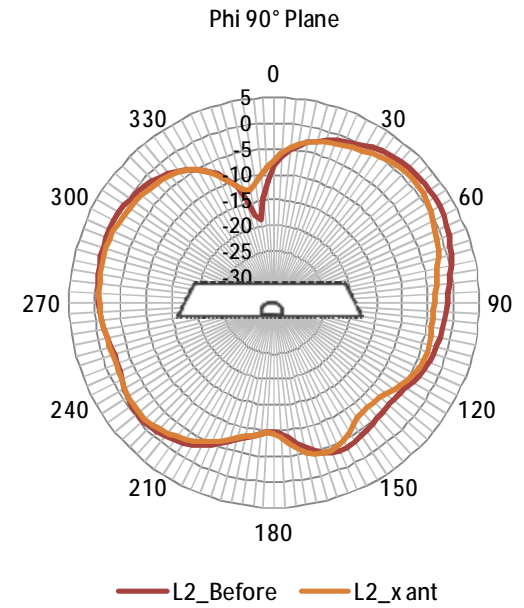
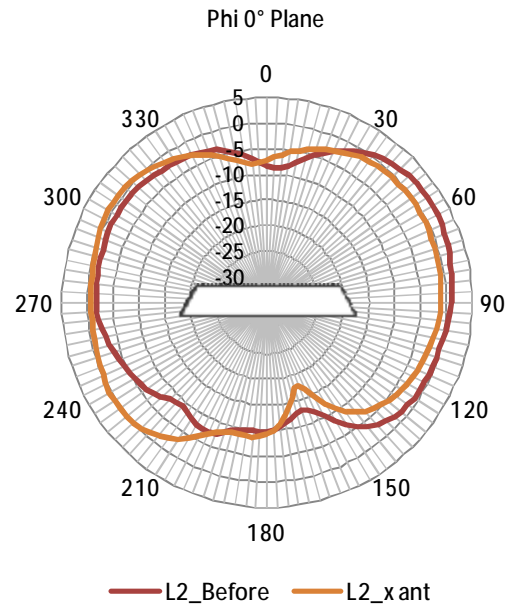
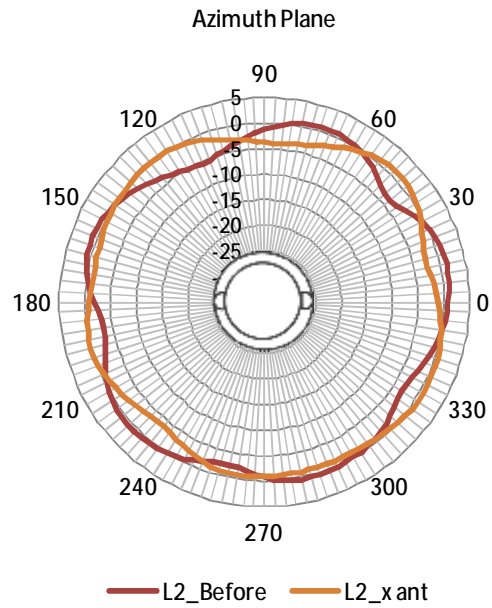

Radiation Pattern at 4900 MHz – Ant H1

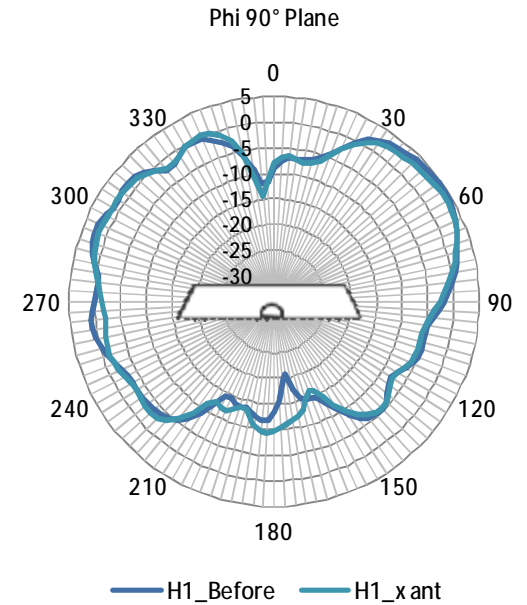
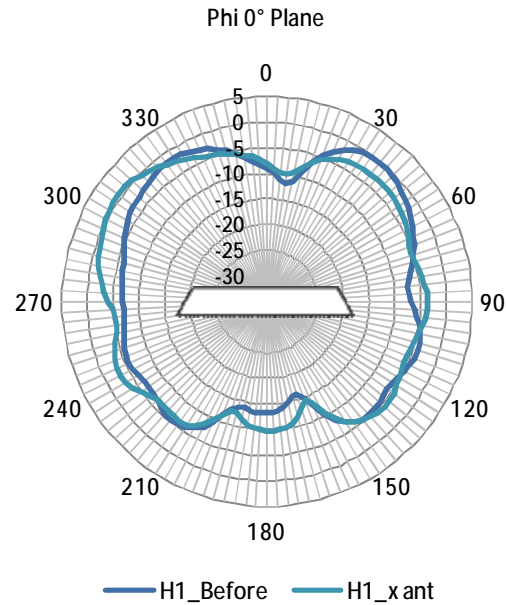
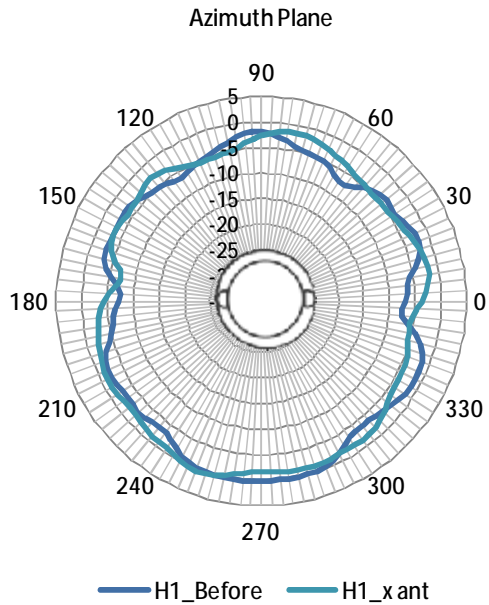

Radiation Pattern at 5150 MHz – Ant H1

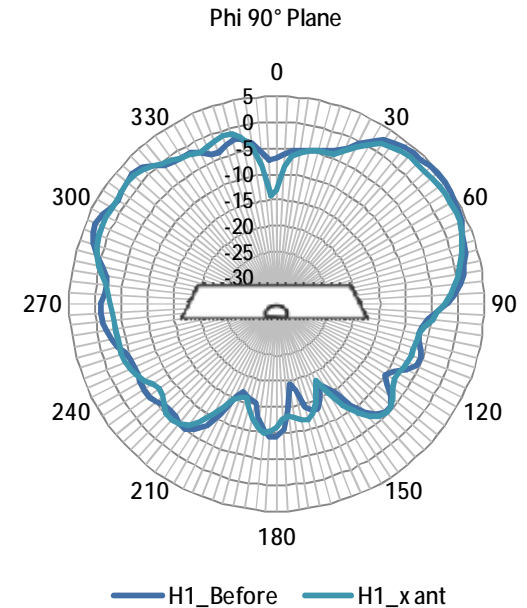
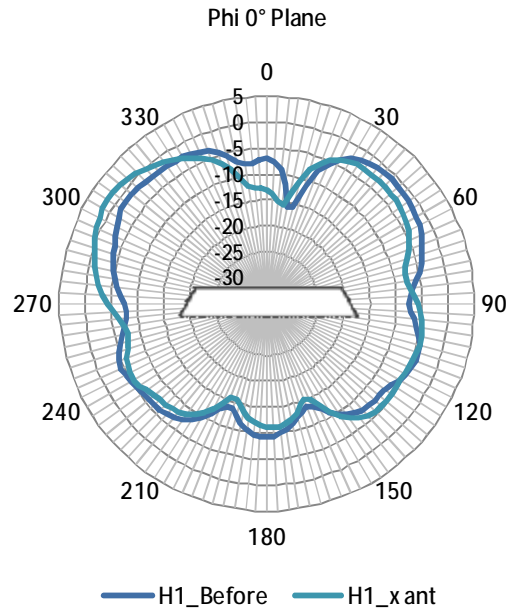
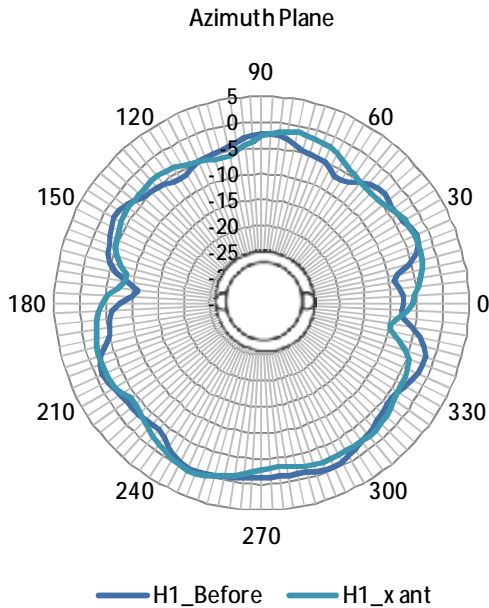

Radiation Pattern at 5350 MHz – Ant H1

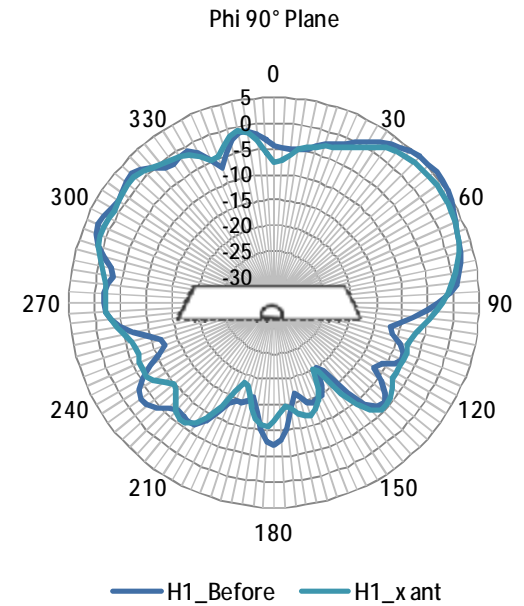
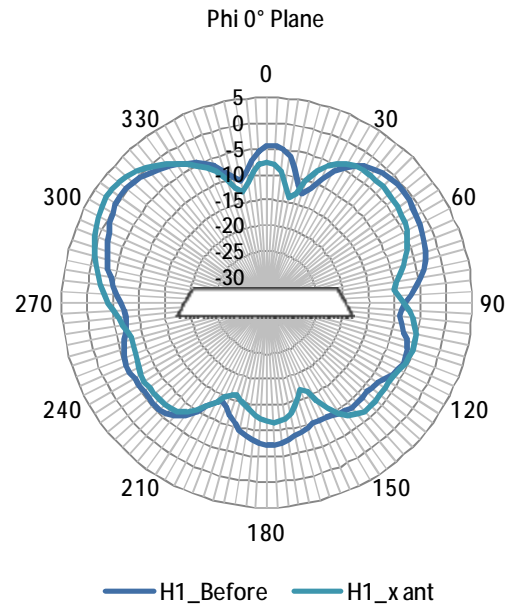
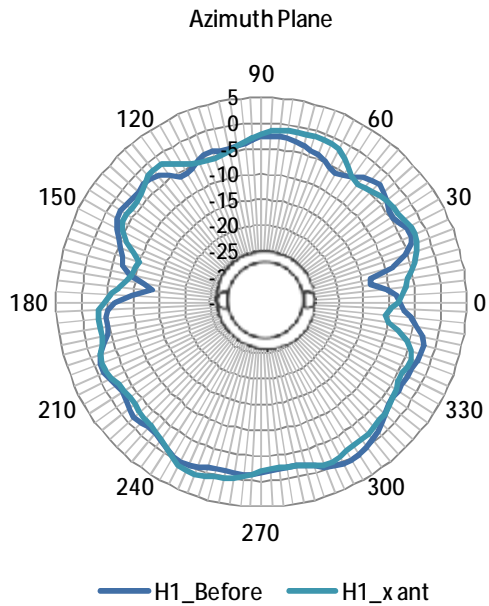

Radiation Pattern at 5470 MHz – Ant H1

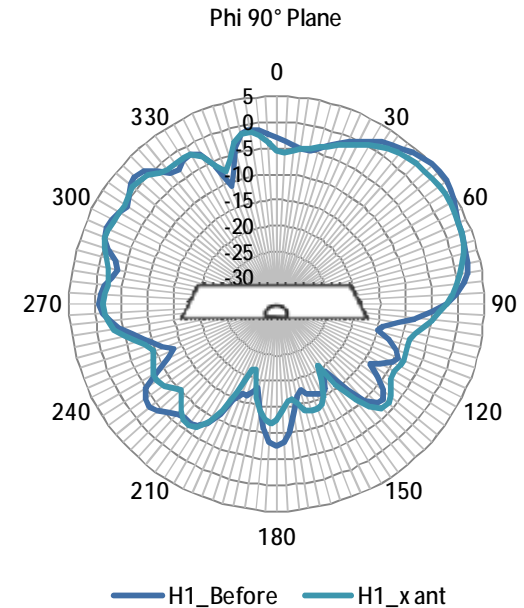
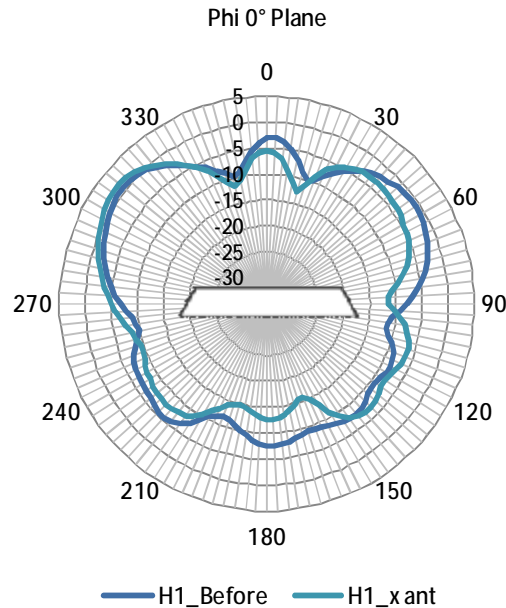
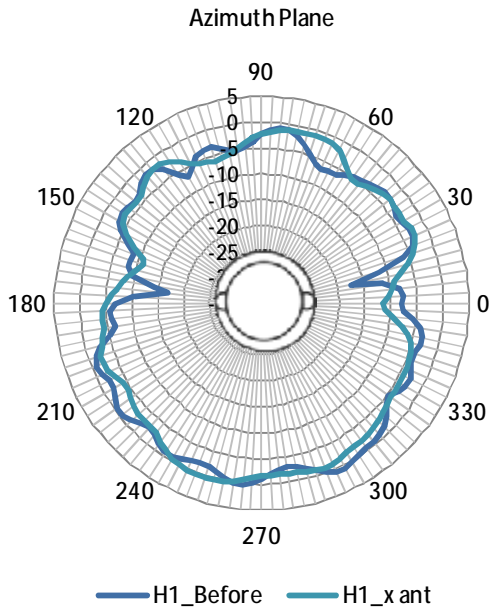

Radiation Pattern at 5725 MHz – Ant H1

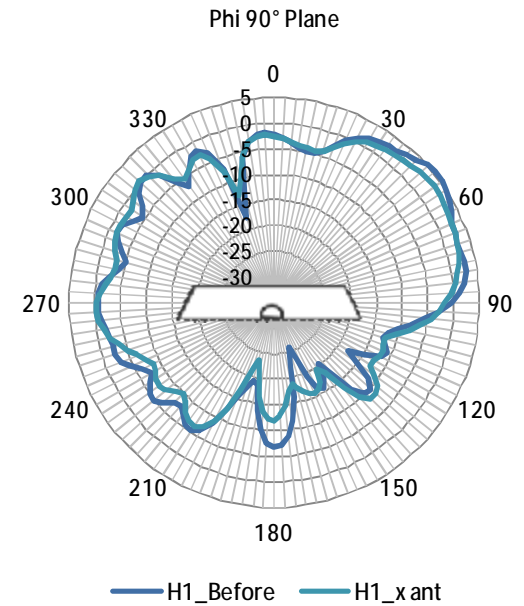
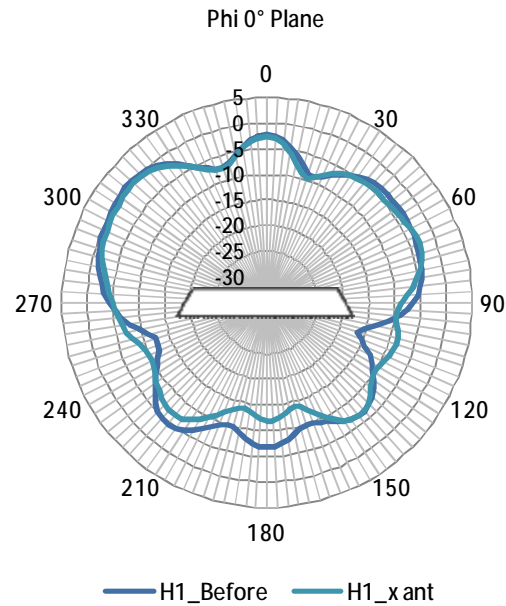
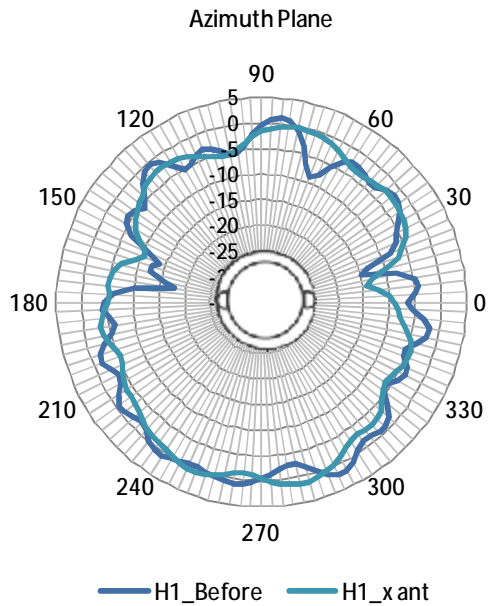

Radiation Pattern at 5875 MHz – Ant H1

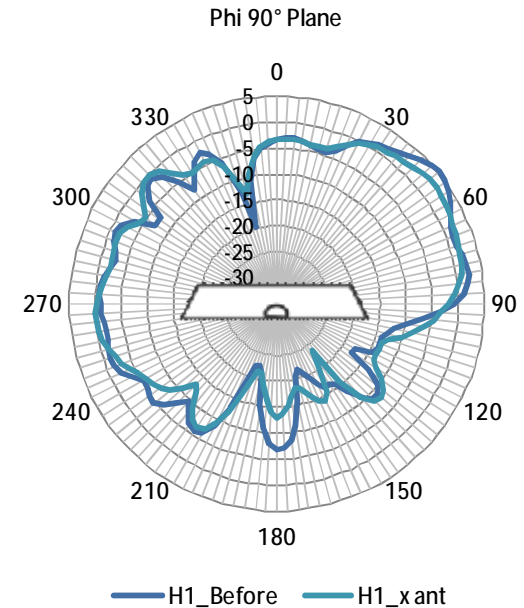
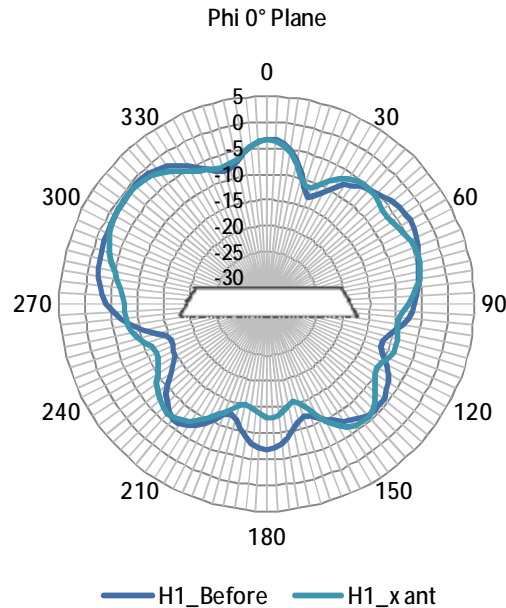
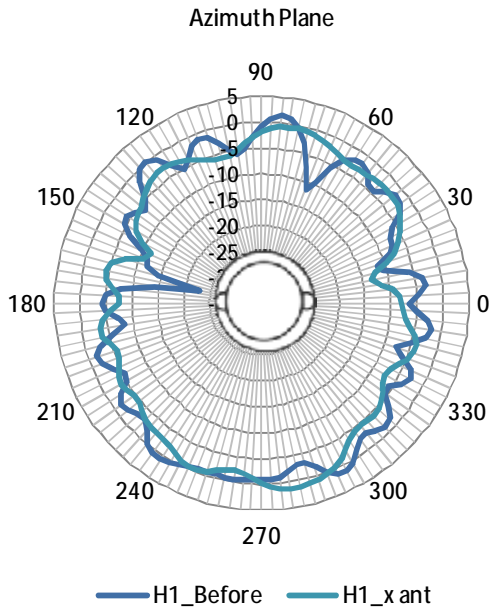

Radiation Pattern at 4900 MHz – Ant H2

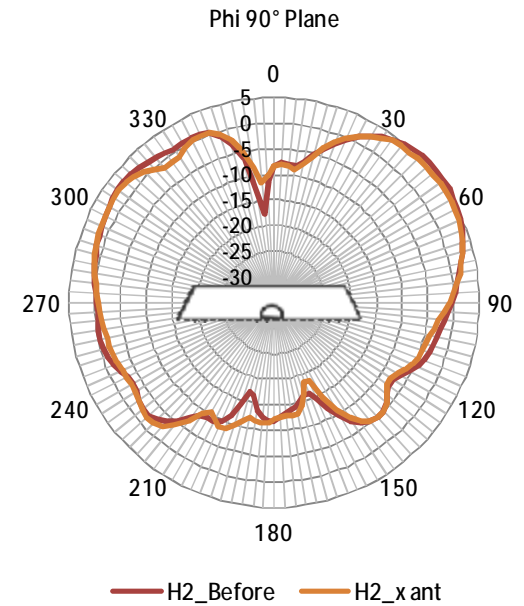
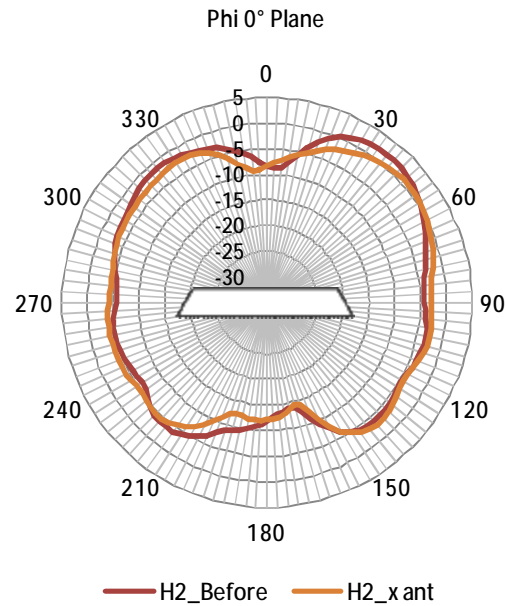
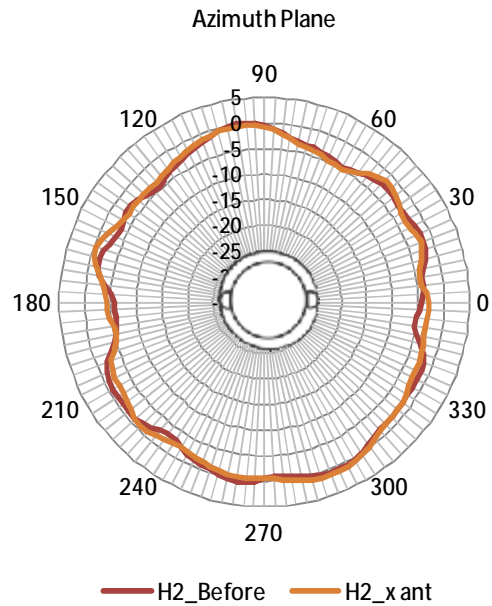

Radiation Pattern at 5150 MHz – Ant H2

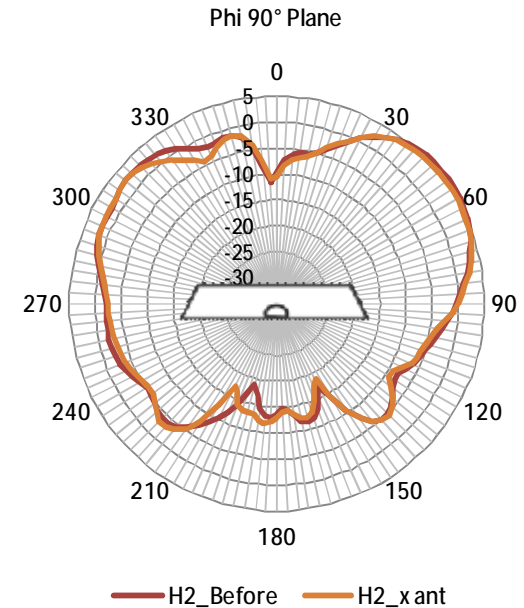
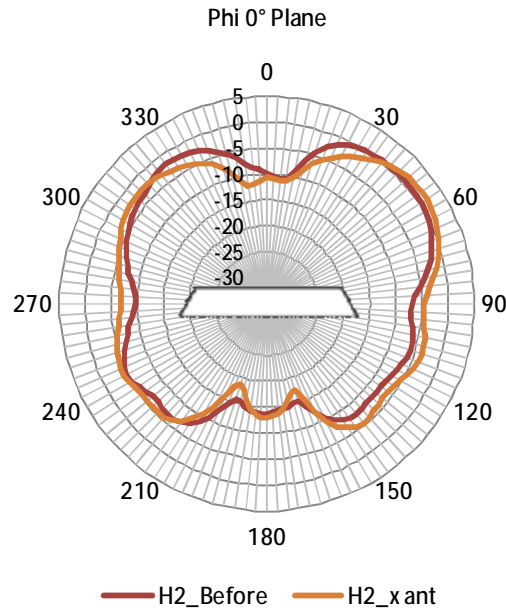
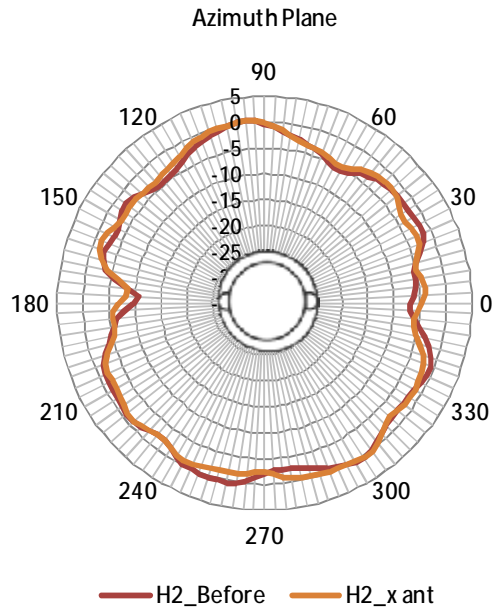

Radiation Pattern at 5350 MHz – Ant H2

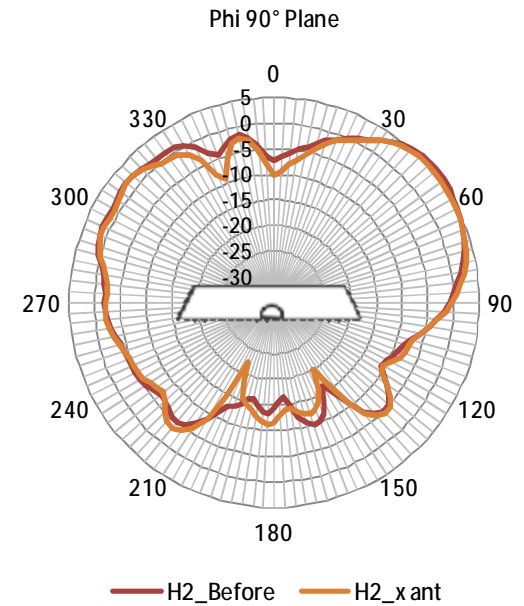
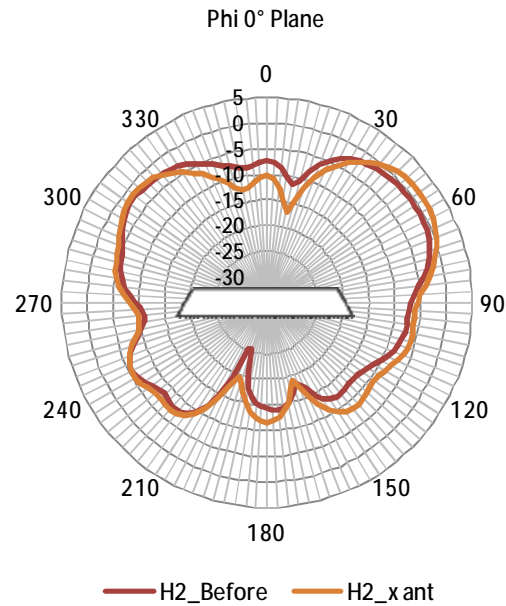
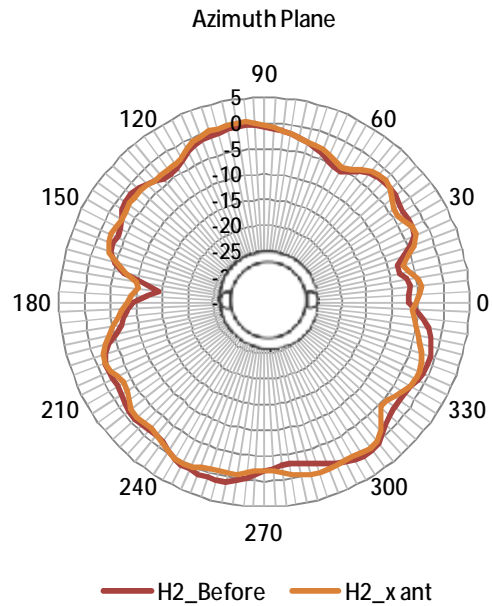

Radiation Pattern at 5470 MHz – Ant H2

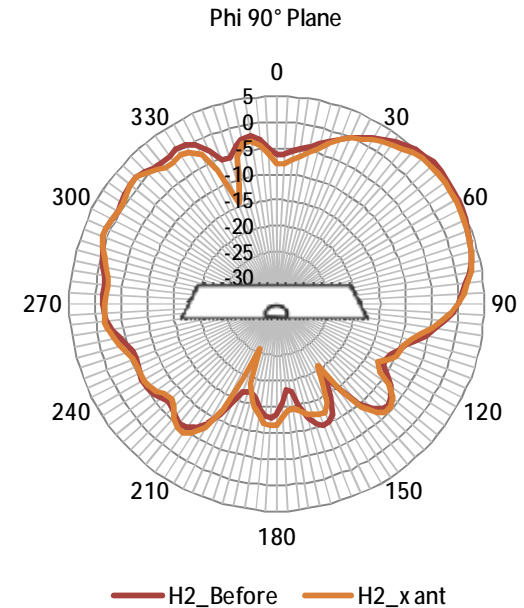
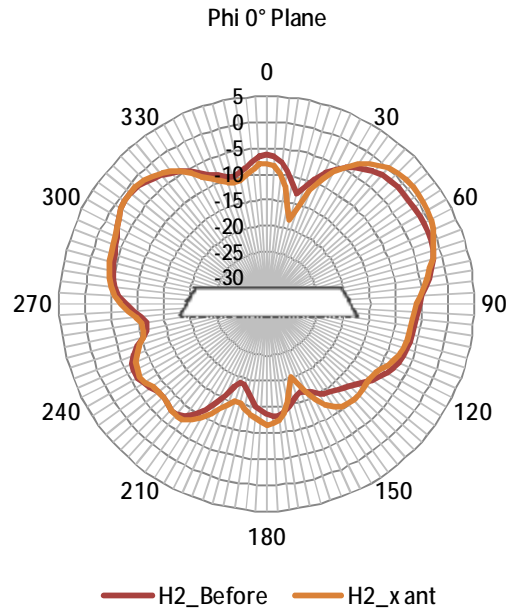
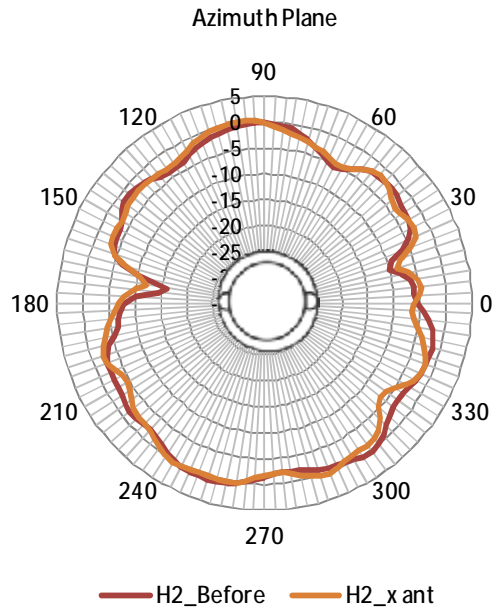

Radiation Pattern at 5725 MHz – Ant H2

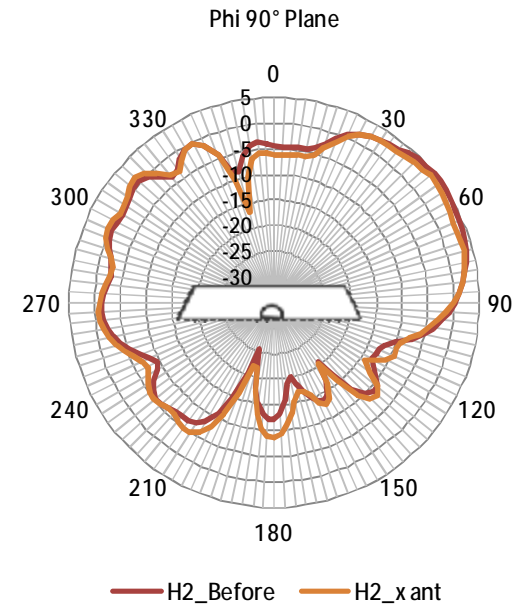
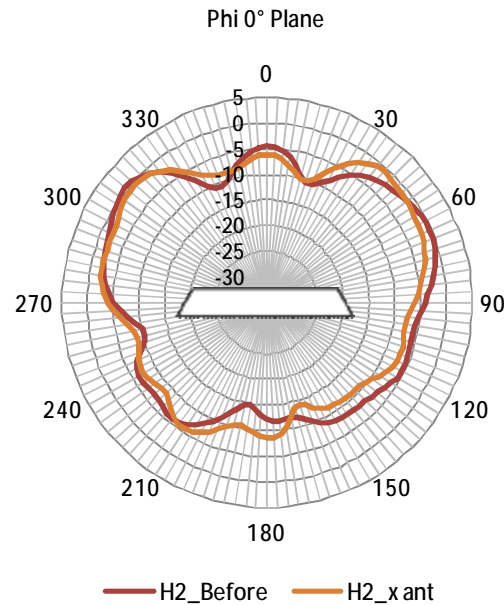
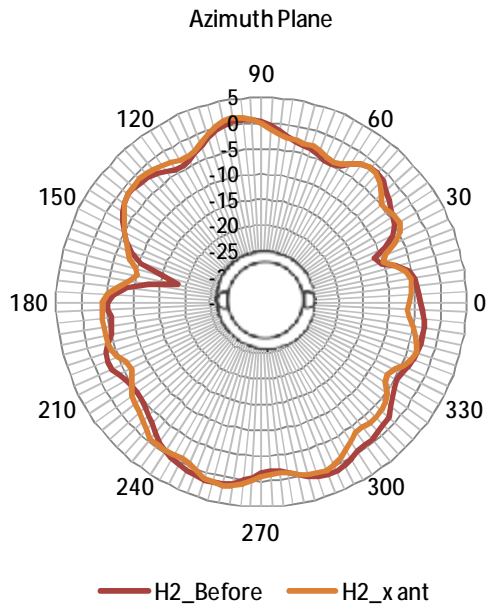

Radiation Pattern at 5875 MHz – Ant H2

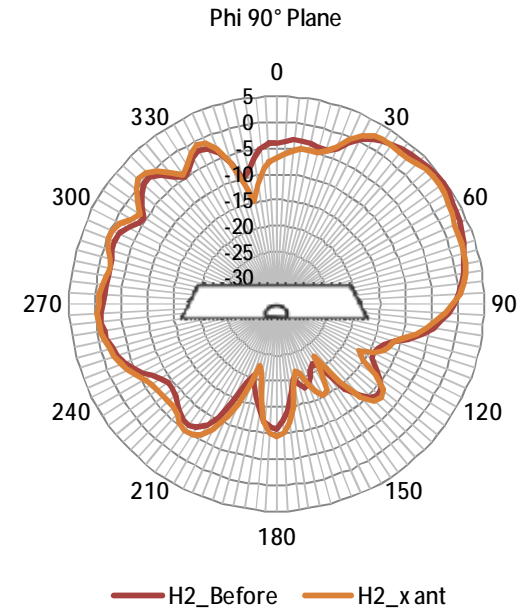
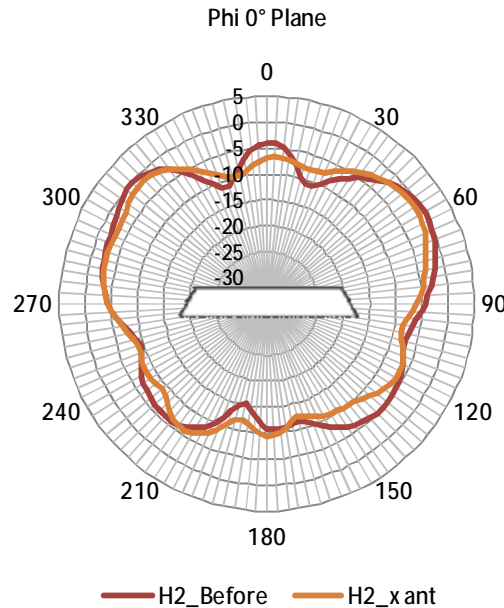
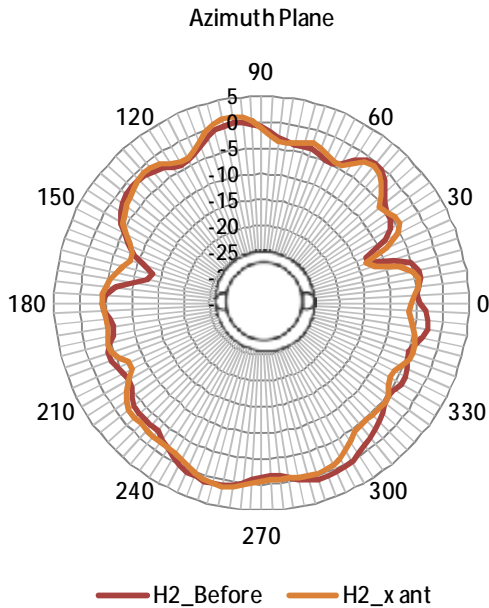

Federal Communications Commission (FCC) Interference Statement

This equipment has been tested and found to comply with the limits for a Class B digital device, pursuant to Part 15 of the FCC Rules.

These limits are designed to provide reasonable protection against harmful interference in a residential installation. This equipment generate, uses and can radiate radio frequency energy and, if not installed and used in accordance with the instructions, may cause harmful interference to radio communications.

However, there is no guarantee that interference will not occur in a particular installation. If this equipment does cause harmful interference to radio or television reception, which can be determined by turning the equipment off and on, the user is encouraged to try to correct the interference by one of the following measures:

- Reorient or relocate the receiving antenna.
- Increase the separation between the equipment and receiver.
- Connect the equipment into an outlet on a circuit different from that to which the receiver is connected.
- Consult the dealer or an experienced radio/TV technician for help.

This device complies with Part 15 of the FCC Rules. Operation is subject to the following two conditions: (1) This device may not cause harmful interference, and (2) this device must accept any interference received, including interference that may cause undesired operation.

FCC Caution: Any changes or modifications not expressly approved by the party responsible for compliance could void the user's authority to operate this equipment.

RF exposure warning

This equipment complies with FCC radiation exposure limits set forth for an uncontrolled environment.

This equipment must be installed and operated in accordance with provided instructions and the antenna(s) used for this transmitter must be installed to provide a separation distance of at least 20 cm from all persons and must not be collocated or operating in conjunction with any other antenna or transmitter.

Antenna warning

The users were prohibited to use the extra antenna whose antenna gain higher than the external antenna gain which max directional gain is 8.94 dBi.

IC Radiation Exposure Statement for Canada

This device complies with Industry Canada licence-exempt RSS standard(s). Operation is subject to the following two conditions: (1) this device may not cause interference, and (2) this device must accept any interference, including interference that may cause undesired operation of the device.

Le présent appareil est conforme aux CNR d'Industrie Canada applicables aux appareils radio exempts de licence. L'exploitation est autorisée aux deux conditions suivantes : (1) l'appareil ne doit pas produire de brouillage, et (2) l'utilisateur de l'appareil doit accepter tout brouillage radioélectrique subi, même si le brouillage est susceptible d'en compromettre le fonctionnement.

Under Industry Canada regulations, this radio transmitter may only operate using an antenna of a type and maximum (or lesser) gain approved for the transmitter by Industry Canada. To reduce potential radio interference to other users, the antenna type and its gain should be so chosen that the equivalent isotropically radiated power (e.i.r.p.) is not more than that necessary for successful communication.

Conformément à la réglementation d'Industrie Canada, le présent émetteur radio peut fonctionner avec une antenne d'un type et d'un gain maximal (ou inférieur) approuvé pour l'émetteur par Industrie Canada. Dans le but de réduire les risques de brouillage radioélectrique à l'intention des autres utilisateurs, il faut choisir le type d'antenne et son gain de sorte que la puissance isotrope rayonnée équivalente (p.i.r.e.) ne dépasse pas l'intensité nécessaire à l'établissement d'une communication satisfaisante.

User manuals for transmitters equipped with detachable antennas shall also contain the following notice in a conspicuous location:

This radio transmitter (identify the device by certification number, or model number if Category II) has been approved by Industry Canada to operate with the antenna types listed below with the maximum permissible gain and required antenna impedance for each antenna type indicated. Antenna types not included in this list, having a gain greater than the maximum gain indicated for that type, are strictly prohibited for use with this device.

Le présent émetteur radio (identifier le dispositif par son numéro de certification ou son numéro de modèle s'il fait partie du matériel de catégorie I) a été approuvé par Industrie Canada pour fonctionner avec les types d'antenne énumérés ci-dessous et ayant un gain admissible maximal et l'impédance requise pour chaque type d'antenne. Les types d'antenne non inclus dans cette liste, ou dont le gain est supérieur au gain maximal indiqué, sont strictement interdits pour l'exploitation de l'émetteur.

IMPORTANT NOTE:

Radiation Exposure Statement:

This equipment complies with "Industry Canada RSS-102 for radiation exposure limits set forth for an uncontrolled environment".

This equipment should be installed and operated with minimum distance 20cm between the radiator and your body.