



User Guide

Wireless LAN PC Card

3CRPAG175

<http://www.3com.com/>

Published June 2003
User guide version 1.0.0

3Com Corporation ■ 5500 Great American Parkway ■ Santa Clara, California ■ 95052-8145

Copyright © 2003 3Com Corporation. All rights reserved. No part of this documentation may be reproduced in any form or by any means or used to make any derivative work (such as translation, transformation, or adaptation) without written permission from 3Com Corporation.

3Com Corporation reserves the right to revise this documentation and to make changes in content from time to time without obligation on the part of 3Com Corporation to provide notification of such revision or change.

3Com Corporation provides this documentation without warranty, term, or condition of any kind, either implied or expressed, including, but not limited to, the implied warranties, terms or conditions of merchantability, satisfactory quality, and fitness for a particular purpose. 3Com may make improvements or changes in the product(s) and/or the program(s) described in this documentation at any time.

3Com is a registered trademark and the 3Com logo is a trademark of 3Com Corporation. Microsoft and Windows are registered trademarks of Microsoft Corporation. All other company and product names may be trademarks of the respective companies with which they are associated.

Unless otherwise indicated, 3Com registered trademarks are registered in the United States and may or may not be registered in other countries.

If there is any software on removable media described in this documentation, it is furnished under a license agreement included with the product as a separate document or in the hard copy documentation. If you are unable to locate a copy, please contact 3Com and a copy will be provided to you.

UNITED STATES GOVERNMENT LEGEND

If you are a United States government agency, then this documentation and the software described herein are provided to you subject to the following:

All technical data and computer software are commercial in nature and developed solely at private expense. Software is delivered as "Commercial Computer Software" as defined in DFARS 252.227-7014 (June 1995) or as a "commercial item" as defined in FAR 2.101(a) and as such is provided with only such rights as are provided in 3Com's standard commercial license for the software. Technical data is provided with limited rights only as provided in DFAR 252.227-7015 (Nov 1995) or FAR 52.227-14 (June 1987), whichever is applicable. You agree not to remove or deface any portion of any legend provided on any licensed program or documentation contained in, or delivered to you in conjunction with, this user guide.

Contents

| | | |
|----------|--|-----------|
| 1 | Installing Your Wireless LAN PC Card and Wireless LAN Manager | 1 |
| | Installation CD | 1 |
| | Windows XP, 2000, Me, and 98 SE | 1 |
| | Inserting Your Wireless LAN PC Card | 2 |
| | Antennas | 2 |
| | Using Wireless LAN Manager | 2 |
| | Getting Connected with 3Com Wireless LAN Manager | 3 |
| | Creating New Connections | 4 |
| 2 | Troubleshooting | 7 |
| | Confirming Device Installation | 7 |
| | Diagnosing Problems | 7 |
| | Wireless LAN Adapter LED Indicators | 8 |
| | Removing Your Wireless LAN PC Card | 8 |
| | Updating the Wireless LAN PC Card Driver | 8 |
| | Windows XP and 2000 | 9 |
| | Windows Me and 98 SE | 9 |
| A | Technical Support | 11 |
| | Online Technical Services | 11 |
| | World Wide Web Site | 11 |
| | 3Com Knowledgebase Web Services | 11 |
| | 3Com FTP Site | 11 |
| | Support from Your Network Supplier | 12 |
| | Support from 3Com | 12 |
| | Returning Products for Repair | 12 |
| | Regulatory Compliance Information | 13 |
| | FCC Part 15 Notice (Applicable to use within the USA) | 13 |
| | Unintentional Radiator | 13 |
| | Manufacturer's Declaration of Conformity | 14 |
| | Industry Canada Notice (Applicable for use within Canada) | 14 |
| | Avis de conformité à la réglementation d'Industrie Canada | 14 |
| | Industry Canada (IC) Emissions Compliance Statement | 14 |
| | Avis de conformité à la réglementation d'Industrie Canada | 14 |
| | Safety Notice | 14 |
| | European Community CE Notice | 15 |

1 Installing Your Wireless LAN PC Card and Wireless LAN Manager

Installation CD

The *Installation CD* contains:

- "Setup programs and drivers for Windows XP, 2000, Millennium Edition (Windows Me), 98 Second Edition (SE) and Embedded XP
- 3Com Wireless LAN Manager
- "README.TXT file with updated information about your Wireless LAN PC Card
- This *Wireless LAN PC Card User Guide*
- Adobe Acrobat Reader

Windows XP, 2000, Me, and 98 SE

If you are accessing this guide as part of your LAN PC Card installation, skip to step 3 below.

- 1 With the computer on and Windows running, insert the *Installation CD* into the CD-ROM drive. The auto-start feature starts the installation. If nothing happens within five seconds, click *Start > Run* and type **d:\setup.exe** (where d: is your CD-ROM drive).
- 2 From the 3Com Wireless Installer main menu, select *Install Wireless Product*.
- 3 Wait for the installation program will prompt you to insert the PC Card into the slot (see the illustrations in the next section, "Inserting Your Wireless LAN PC Card").
- 4 Your machine will run through the hardware installation and automatically launch the Wireless LAN Manager software installation. Respond to the prompts as they appear.
- 5 During the installation process, you may receive prompts for the Windows installation CD. Insert the CD for your Windows operating system and indicate the correct path. Your computer goes through a brief installation process during which it displays several windows indicating what is currently installing.
- 6 Restart the computer whenever you are prompted.
- 7 When your computer restarts you will be prompted to select country you will using the 3CRPAG175 Wireless LAN PC Card. It is very important that you select the correct country so product is properly configured for that country.
- 8 Your installation is now complete.

Inserting Your Wireless LAN PC Card

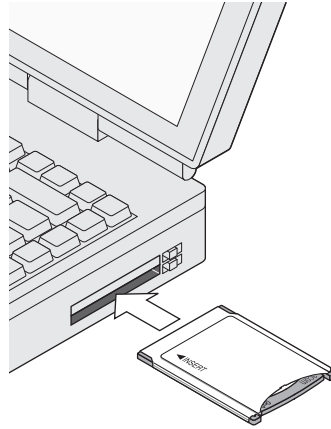

3CRPAG175

Antennas

The antenna on the 3CRPAG175 Wireless LAN PC Card is an XJACK antenna. Extend or retract the antenna like a ball-point pen—press it to extend and use it, press it again to retract or disable it.



NOTE: The antenna on the 3CRPAG175 Wireless LAN PC Card must be extended for you to connect to your wireless network

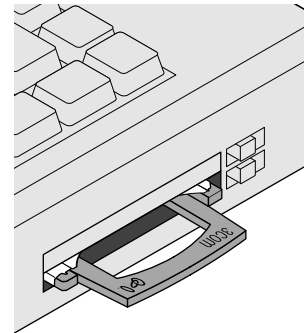
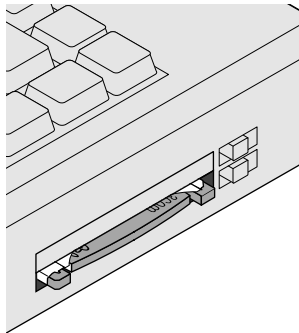

Using Wireless LAN Manager



NOTE: Wireless LAN Manager defaults to automatically connect to any wireless network and no security. This default allows a basic connection to an access point.

Key Features contained within 3Com Wireless LAN Manager:

- Ad Hoc or Access Point connections
- Wide range of security settings: including

- 64, 128, 152 bit WEP
- Light EAP
- 802.1x - EAP-TLS, PEAP
- WPA (64/128/152/AES)
- TTLS
- MD5
- 3Com Dynamic Security Link
- Serial Authentication
- Multiple profile support with automatic profile activation capabilities
 - Profiles can be imported and exported for easy multiple machine setup
- For each profiles you can specify:
 - SSID name
 - Security settings
 - Applications that will automatically launch, such as VPN software
 - Default printer
 - File and print sharing for each profile
 - Static or Dynamic IP settings

After installation, consult with your network administrator and refer to 3Com's Wireless LAN Manager on line help for detailed information about the Wireless LAN Manager features and to change your default installation settings.

Getting Connected with 3Com Wireless LAN Manager

Your 3Com Wireless LAN PC card has been initially setup as follows:

- Network Name: This has been set to allow you to connect to any Access Point without encryption or authentication.
- Encryption: No encryption has been enabled.



If 3Com Wireless LAN Manager does not show an active connection or you want to connect to a different wireless LAN network then you will need to create a new connection.

Creating New Connections

To make a Wireless LAN connection, click the Create New Connection button from the 3Com Launcher application.



This will bring up the “New Connection” window.

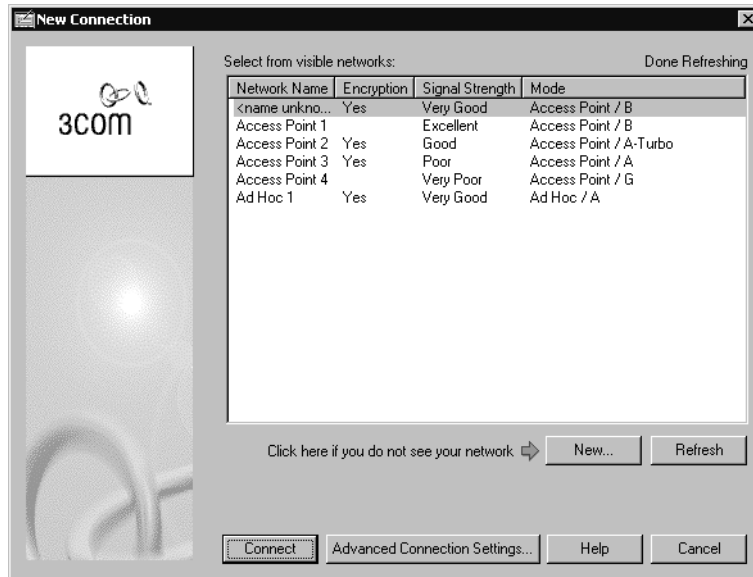

The new connection window will show a list of all the Wireless LAN connections that are available, and the type of network they are.

“Access Point” networks are those with a device (Access Point) that you can use to connect to a standard network. “Ad Hoc” networks are for allowing direct connections between two or more computers with Wireless LAN devices. They are useful if no Access Points are available.

If you see an Access Point connection with the network name “<name unknown>”, then the Access Point is choosing to not broadcast its SSID (network name). In this case, you must know the name of the network before you can connect to it.



After you have selected the network you want to connect to, click the **Connect** or **Advanced** button.

The **Connect** button will ask you for the minimum amount of information you need to make a connection.

The **Advanced** button will allow you to specify additional information:



- If you want to automatically make a VPN connection
- If you want to automatically launch an application
- The TCP/IP settings for the network
- Advanced settings

After you complete the connection, the connection information will be stored in a profile with the network name of that connection.

From the 3Com Launcher application, you can return to the profile you have just created by clicking on the **Options Menu** () button and selecting that profile from the menu. After you have created multiple profiles, you can also switch between them with the **Options Menu** () button. Selecting the "Automatic Profile Selection" option allows Wireless LAN Manager to try to choose the best profile for you depending on your location.

The **Profile Manager** () button activates the Wireless LAN Profile Manager application. You can use this application to activate profiles, edit profiles, create new profiles, and import or export profiles. You can also determine which profiles will be used if the "Automatic Profile Selection" option is selected, and in what order they will be tried.

The **Edit Current Profile** () button allows you to make changes to the currently selected profile. You can also make changes to a profile from the Wireless LAN Profile Manager, or by creating a new connection for the network name (which will overwrite the current profile).

The **Diagnostics** () button will display information about the current connection. The **Help** () button will display information about the status of the current connection.

2 Troubleshooting

Confirming Device Installation

- 1 With your PC Card installed in the computer, double-click the *My Computer* icon. If you are running Windows XP, click *Start > Control Panel* and go to step 3.
- 2 Double-click the *Control Panel* icon.
- 3 Double-click the *System* icon. The System Properties window appears, detailing your system setup.
- 4 Click the *Device Manager* tab. A list of devices appears, arranged by type. If you are using Windows XP or 2000, click the *Hardware* tab and click *Device Manager*.
- 5 Double-click *Network Adapters*. Select: *3Com 3CRPAG175 Wireless LAN PC Card*
- 6 Double-click the entry to display a description of the current status. The device status should indicate "This device is working properly."
- 7 Close the windows you have opened until you return to the desktop.

Diagnosing Problems

If you have difficulty using the Wireless LAN PC Card, try the solutions in the following table. If you continue to experience difficulty, see the next two sections, "Uninstalling the PC Card" and "Uninstalling Wireless LAN Manager."

| Problem | Solutions |
|--|---|
| Wireless LAN PC Card LED is off | Make sure the PC Card is properly inserted in the slot and that the XJACK antenna is fully extended. Check the Wireless LAN PC Card icon in the Windows control panel and make sure the PC Card type can be recognized. |
| Wireless LAN PC Card installs as an unknown device | Remove the unknown device and repeat the installation procedure. Make sure you insert the 3Com CD when the installation calls for it and that you wait for it to come up to speed in the drive. |
| The Windows Add Hardware Wizard was unable to locate the Wireless LAN PC Card drivers. | You may have had no CD or the wrong CD inserted in the drive, or the 3Com CD may not have been ready when the wizard looked for the drivers. |
| Installation program does not finish or the driver fails to load | Use the Device Manager to resolve resource conflicts that may exist. Select System from the Control Panel, and then click the Device Manager tab. |
| Network association is intermittent. | Make sure the XJACK antenna is fully extended. Try reorienting your laptop. For best use of the antenna: <ul style="list-style-type: none">■ Keep the area around the antenna clear from materials that could block radio transmission, such as metal objects, electronic devices, and cordless telephones.■ If the signal is weak, change the direction of your laptop slightly.■ If necessary, move your computer a few inches to find a better signal. |
| Computer operating system does not recognize the card | Make sure the PC Card is properly inserted in the slot and PCMCIA support is installed. Check whether a card is already in use. Windows XP, 2000, Me, and 98 SE: Check whether the computer has a Plug-and-Play BIOS. Visit www.3com.com to download the latest drivers. Refer to the Updating the Wireless LAN PC Card Driver section below. |

| Problem | Solutions |
|--|---|
| No network association exists when the computer becomes active again after being in sleep mode or after the Wireless LAN PC Card is removed and reinserted | Log out and log in again, or restart the computer to restore the connections. |

Wireless LAN Adapter LED Indicators

| Condition | Description |
|---------------------|---|
| Off | The computer does not recognize the Wireless LAN Adapter. |
| Flashing on and off | The Wireless LAN Adapter has power. |
| Flickering | Data transfer is taking place. |

Removing Your Wireless LAN PC Card

Normally, you would not uninstall the Wireless LAN PC Card; however, in case a problem arises, you may want to uninstall and reinstall it. You can uninstall Wireless LAN Manager any time following the installation. The uninstall removes desktop icons, registry entry files, and files used by the adapter.

- 1 If you are using Windows 2000, Me, or 98 SE, click *Start > Settings > Control Panel*. If you are using Windows XP, click *Start > Control Panel*.
- 2 Click *Add/Remove Programs*.
- 3 Select *3Com Wireless LAN Manager*.
- 4 Click *Change/Remove*.
- 5 Click *Remove*.
- 6 When the uninstall is complete, remove the adapter and restart your computer.

Updating the Wireless LAN PC Card Driver

To update your Wireless LAN PC Card driver software, find your operating system below, then follow the procedure.

Windows XP and 2000

- 1 Insert your Wireless LAN PC Card into the PC card slot.
- 2 In Windows 2000, select *Start > Settings > Control Panel*, then double-click the *System* icon. In Windows XP, from your desktop or start menu, right-click *My Computer* and select *Properties*.
- 3 Select the *Hardware* tab and click *Device Manager*.
- 4 If necessary, click the plus sign (+) to expand the Network Adapters tree.
- 5 In Windows 2000, double-click the entry: *3Com 3CRWPAG175 Wireless LAN PC Card* select the *Driver* tab, and click *Update Driver*. In Windows XP, right-click *3Com Wireless LAN Adapter* and select *Update Driver*.
- 6 Insert the Installation CD. The Hardware Update Wizard window appears.
- 7 In Windows 2000, click *Display list of known drivers so that I can choose a specific driver* and click *Next*. In Windows XP, select *Install from a list or specific location (Advanced)* and click *Next*.
- 8 In Windows XP, select *Don't search. I will choose the driver to install* and click *Next*.
- 9 When you are prompted to select an adapter, click *Have Disk...* and enter the drive letter for the *Installation CD* or enter the directory on your hard drive where the updated driver is located. Click *Continue*.
- 10 Select either *3Com 3CRPAG175 LAN PC* and click *Next*. Follow the prompts through the remainder of the driver update.
- 11 When the installation has completed, click *Finish*.

Windows Me and 98 SE

- 1 Insert your Wireless LAN PC Card into the PC card slot.
- 2 From the Windows Start menu, select *Settings*, then select *Control Panel*.
- 3 Double-click the *System* icon, then select *Device Manager*.
- 4 In the Device Manager window, expand the Network Adapters list.
- 5 Select either *3Com 3CRPAG175 Wireless LAN PC Card* and click *Properties*.
- 6 Select *Driver* and click *Update Driver*.
- 7 In the Update Device Driver Wizard, follow the prompts to install the upgrade.
- 8 When prompted, click *Restart* for the changes to take effect.

A

Technical Support

3Com provides easy access to technical support information through a variety of services. This appendix describes these services.

Information contained in this appendix is correct at time of publication. For the most recent information, 3Com recommends that you access the 3Com Corporation World Wide Web site.

Online Technical Services

3Com offers worldwide product support 24 hours a day, 7 days a week, through the following online systems:

- World Wide Web site
- 3Com Knowledgebase Web Services
- 3Com FTP site

World Wide Web Site

To access the latest networking information on the 3Com Corporation World Wide Web site, enter this URL into your Internet browser:

`http://www.3com.com/`

This service provides access to online support information, such as technical documentation and a software library, as well as support options that range from technical education to maintenance and professional services.

3Com Knowledgebase Web Services

The 3Com Knowledgebase is a database of technical information to help you install, upgrade, configure, or support 3Com products. The Knowledgebase is updated daily with technical information discovered by 3Com technical support engineers. This complimentary service, which is available 24 hours a day, 7 days a week to 3Com customers and partners, is located on the 3Com Corporation World Wide Web site at:

`http://knowledgebase.3com.com`

3Com FTP Site

Download drivers, patches, software, and MIBs across the Internet from the 3Com public FTP site. This service is available 24 hours a day, 7 days a week.

To connect to the 3Com FTP site, enter the following information into your FTP client:

- Hostname: **`ftp.3com.com`**
- Username: **`anonymous`**
- Password: **`<your Internet e-mail address>`**



NOTE: With Web browser software, such as Netscape Navigator and Internet Explorer, you do not need a user name and password.

Support from Your Network Supplier

If you require additional assistance, consult your network supplier. Many suppliers are authorized 3Com service partners who are qualified to provide a variety of services, including network planning, installation, hardware maintenance, application training, and support services.

When you consult your network supplier, have the following information ready:

- Product model name, part number, and serial number
- A list of system hardware and software, including revision levels
- Diagnostic error messages
- Details about recent configuration changes, if applicable

If you are unable to consult your network supplier, see the following section on how to contact 3Com.

Support from 3Com

If you are unable to obtain assistance from the 3Com online technical resources or from your network supplier, 3Com offers technical telephone support services. To find out more about your support options, go to the Web site associated with your region of the world shown below.

| Region | URL for Regional Web Site |
|-------------------------------------|--|
| Asia and the Pacific Rim | ap.3com.com/support |
| Africa, Europe, and the Middle East | emea.3com.com/support/supportnumbers.html |
| Latin America | lat.3com.com/ |
| North America | csoweb4.3com.com/contactus |

When you contact 3Com for assistance, have the following information ready:

- Product model name, part number, and serial number
- A list of system hardware and software, including revision levels
- Diagnostic error messages
- Details about recent configuration changes, if applicable

Returning Products for Repair

Before you send a product directly to 3Com for repair, you must first obtain an authorization number. Products sent to 3Com without authorization numbers will be returned to the sender unopened, at the sender's expense. To obtain an authorization number, go to the Web site listed above for your region.

Regulatory Compliance Information



NOTE: This product contains encryption. It is unlawful to export out of the U.S. without obtaining a U.S. Export License.

FCC Part 15 Notice (Applicable to use within the USA)



CAUTION: FCC Radio-Frequency Exposure Notice

This device generates and radiates radio-frequency energy. In order to comply with FCC radio-frequency radiation exposure compliance requirements, a separation distance of at least 2.5 cm (1.0 inch) must be maintained between the antenna of the device and all persons.

This product does not contain any user serviceable components. Any unauthorized product changes or modifications will invalidate 3Com's warranty and all applicable regulatory certifications and approvals.

Unintentional Radiator



WARNING: This equipment has been tested and found to comply with the limits for a Class B digital device as applicable, pursuant to Part 15 of the FCC Rules. These limits are designed to provide reasonable protection against harmful interference in a residential installation. This equipment generates, uses and can radiate radio frequency energy and, if not installed and used in accordance with the instructions, may cause harmful interference to radio communications. However, there is no guarantee that interference will not occur in a particular installation. If this equipment does cause harmful interference to radio or television reception, which can be determined by turning the equipment off and on, the user is encouraged to try to correct the interference by one or more of the following measures:

- Reorient or relocate the receiving antenna.
- Increase the separation between the equipment and receiver.
- Connect the equipment into an outlet on a circuit different from that to which the receiver is connected.
- Consult the dealer or an experienced radio/TV technician for help.

This device complies with part 15 of the FCC Rules. Operation is subject to the following two conditions: (1) This device may not cause harmful interference, and (2) this device must accept any interference received, including interference that may cause undesired operation.

The user may find the following booklet prepared by the Federal Communications Commission helpful:
The Interference Handbook

This booklet is available from the U.S. Government Printing Office, Washington, D.C. 20402. Stock No. 004-000-00345-4.

Manufacturer's Declaration of Conformity

3Com Corporation
3930 W. Parkway Blvd.
PO Box 704010
West Valley City, UT 84119
(800) 527-8677

Declares that the Product:
Date: June 30, 2003
Brand Name: 3Com Corporation
Model Number: SL-3040
Equipment Type: 802.11b/a/g Wireless PC Card

Complies with Part 15 of the FCC rules. Operation is subject to the following two conditions: (1) this device may not cause harmful interference, and (2) this device must accept any interference received, including interference that may cause undesired operation.

Industry Canada Notice (Applicable for use within Canada)

This device complies with Canadian RSS-210.

To prevent radio interference to the licensed service, this device is intended to be operated indoors and away from windows to provide maximum shielding. Equipment (or its transmit antenna) that is installed outdoors is subject to licensing.

The installer of this radio equipment must ensure that the antenna is located or pointed such that it does not emit RF field in excess of Health Canada limits for the general population; consult Safety Code 6, obtainable from Health Canada's website www.hc-sc.gc.ca/rpb.

Avis de conformité à la réglementation d'Industrie Canada

Cet appareil est conforme à la norme CNR-210 du Canada.

Pour empêcher que cet appareil cause du brouillage au service faisant l'objet d'une licence, cet appareil doit être utilisé à l'intérieur seulement et devrait être placé loin des fenêtres afin de fournir un écran de blindage maximal. L'installateur du présent matériel radio doit s'assurer que l'antenne est située ou pointée de manière à ce que cette dernière n'émette pas de champs radioélectriques supérieurs aux limites spécifiées par Santé Canada pour le grand public; consulter le Code de sécurité 6, disponible sur le site Web de Santé Canada, à l'adresse suivante: www.hc-sc.gc.ca/rpb.

Industry Canada (IC) Emissions Compliance Statement

This Class B digital apparatus complies with Canadian ICES-003.

Avis de conformité à la réglementation d'Industrie Canada

Cet appareil numérique de la classe B est conforme à la norme NMB-003 du Canada.

Safety Notice

This device has been tested and certified according to the following safety standards and is intended for use only in Information Technology Equipment which has been tested to these or other equivalent standards:

UL Standard 60950 (3rd Edition)/ CSA C22.2 No. 60950
IEC 60950
EN 60950
3Com Corporation SL-3040
Tested To Comply
With FCC Standards
FOR HOME OR OFFICE USE

European Community CE Notice

Marking by the symbol  indicates compliance with the essential requirements of Directive 73/23/EC and the essential requirements of articles 3.1(b), 3.2 and 3.3 of Directive 1999/5/EC. Such marking is indicative that this equipment meets or exceeds the following technical standards:

- ETS 300 328-2 — Electromagnetic compatibility and Radio spectrum Matters (ERM); Wideband Transmission systems; data transmission equipment operating in the 2,4GHz ISM band and using spread spectrum modulation techniques
- ETN 301 489-17: V.1.1.1 (09-2000) - Electromagnetic compatibility and Radio spectrum Matters (ERM); ElectroMagnetic Compatibility (EMC) standard for radio equipment and services; Part 17: Specific conditions for Wideband data and HIPERLAN equipment
- EN 60950 - Safety of information technology equipment, including electrical business equipment.



NOTE: Due to frequency restrictions, it is necessary to select your country before using this radio device. Refer to your 3Com Wireless LAN Manager online help for details.

3Com Wireless LAN PC Card User Guide version 1.0.0

Published April, 2002