



H3C WA2600 Series WLAN Access Points Installation Manual

Hangzhou H3C Technologies Co., Ltd.
<http://www.h3c.com>

Manual Version: 5PW100-20081111

Copyright © 2008, Hangzhou H3C Technologies Co., Ltd. and its licensors

All Rights Reserved

No part of this manual may be reproduced or transmitted in any form or by any means without prior written consent of Hangzhou H3C Technologies Co., Ltd.

Trademarks

H3C, **H3C**, Aolynk, , H³Care, , TOP G, , IRF, NetPilot, Neocean, NeoVTL, SecPro, SecPoint, SecEngine, SecPath, Comware, Secware, Storware, NQA, VVG, V²G, VⁿG, PSPT, XGbus, N-Bus, TiGem, InnoVision and HUASAN are trademarks of Hangzhou H3C Technologies Co., Ltd.

All other trademarks that may be mentioned in this manual are the property of their respective owners.

Notice

The information in this document is subject to change without notice. Every effort has been made in the preparation of this document to ensure accuracy of the contents, but all statements, information, and recommendations in this document do not constitute the warranty of any kind, express or implied.

Technical Support

customer_service@h3c.com

<http://www.h3c.com>

About This Manual

Organization



H3C WA2600 Series WLAN Access Points Installation Manual is organized as follows:

Chapter	Contents
1 Product Overview	Introduces the hardware configurations, appearance, and interfaces of the H3C WA2600 Series WLAN Access Points.
2 Preparing for Installation	Specifies the environmental requirements for installing the H3C WA2600 Series WLAN Access Points, presents installation precautions, and introduces the installation tools needed.
3 Installing the AP	Introduces how to install the H3C WA2600 Series WLAN Access Points and how to connect the power supply units and the Ethernet cable.

Conventions

The manual uses the following conventions:

Symbols

Convention	Description
 Warning	Means reader be extremely careful. Improper operation may cause bodily injury.
 Caution	Means reader be careful. Improper operation may cause data loss or damage to equipment.

Convention	Description
 Note	Means a complementary description.

Obtaining Documentation

You can access the most up-to-date H3C product documentation on the World Wide Web at this URL: <http://www.h3c.com>.

The following are the columns from which you can obtain different categories of product documentation:

[Products & Solutions]: Provides information about products and technologies.

[Technical Support & Document > Technical Documents]: Provides several categories of product documentation, such as installation, operation, and maintenance.

Documentation Feedback

You can e-mail your comments about product documentation to info@h3c.com.

We appreciate your comments.

Environmental Protection

This product has been designed to comply with the requirements on environmental protection. For the proper storage, use and disposal of this product, national laws and regulations must be observed.

Table of Contents

1 Product Overview	1-1
Introduction.....	1-1
Hardware Configuration	1-2
LEDs	1-3
Interfaces	1-5
2 Preparing for Installation	2-1
Unpacking and Inspection.....	2-1
Preparing Installation Tools.....	2-2
Examining the Installation Site	2-3
Installation Site Selection	2-3
Temperature and Humidity Requirements	2-3
Power Supply.....	2-4
Grounding and Lightning Protection	2-5
3 Installing the AP.....	3-1
Installation Flowchart	3-1
Determining the Installation Position.....	3-1
Installing the AP on a Wall	3-2
Installing the Wall-Mounting Bracket on the Wall	3-2
Installing the AP on the Wall-Mounting Bracket	3-5
Locking the AP onto the Wall-Mounting Bracket (Optional)	3-6
Connecting the Power Supply.....	3-8
Local Power Supply.....	3-8
Power over Ethernet.....	3-8
Connecting the AP to the Network.....	3-9

List of Figures

Figure 1-1 Typical networking using the WA2600 series	1-1
Figure 1-2 Appearance of the WA2600 series	1-2
Figure 1-3 LEDs on the H3C WA2610E-AGN.....	1-3
Figure 1-4 LEDs on the H3C WA2620E-AGN.....	1-3
Figure 1-5 Interfaces on the H3C WA2610E-AGN.....	1-6
Figure 1-6 Interfaces on the H3C WA2620E-AGN.....	1-7
Figure 3-1 Installation flowchart	3-1
Figure 3-2 Screw hole locations and screw hole size	3-3
Figure 3-3 Install the wall-mounting bracket	3-4
Figure 3-4 Fix the AP onto the wall-mounting bracket	3-6
Figure 3-5 Lock the AP onto the wall-mounting bracket.....	3-7
Figure 3-6 Local power supply connection.....	3-8
Figure 3-7 PoE connection.....	3-8
Figure 3-8 Connect the AP to the network	3-9

List of Tables

Table 1-1	Physical dimensions and weight of the WA2600 series	1-2
Table 1-2	Supported protocols and chassis material.....	1-2
Table 1-3	Description of the LEDs on the WA2610E-AGN and WA2620E-AGN.....	1-4
Table 1-4	Descriptions of interfaces on the WA2600 series WLAN access points	1-8
Table 2-1	List of articles in the package	2-1
Table 2-2	List of installation tools.....	2-2
Table 2-3	Environment specifications	2-3
Table 2-4	Nominal voltage and frequency of the low-voltage AC power supply	2-4
Table 2-5	Grounding and lightning protection requirements.....	2-5

1 Product Overview

Introduction

The H3C WA2600 Series WLAN Access Points (hereinafter referred to as the WA2600 series) are one of the 802.11n access point (AP) product series developed by Hangzhou H3C Technologies Co., Ltd. (hereinafter referred to as H3C). The WA2600 series can serve as FIT APs to cooperate with wireless local area network (WLAN) switches or access controllers to provide wireless access for WLAN users.

Figure 1-1 shows a typical scenario of hotspot deployments using the WA2600 series.

Figure 1-1 Typical networking using the WA2600 series

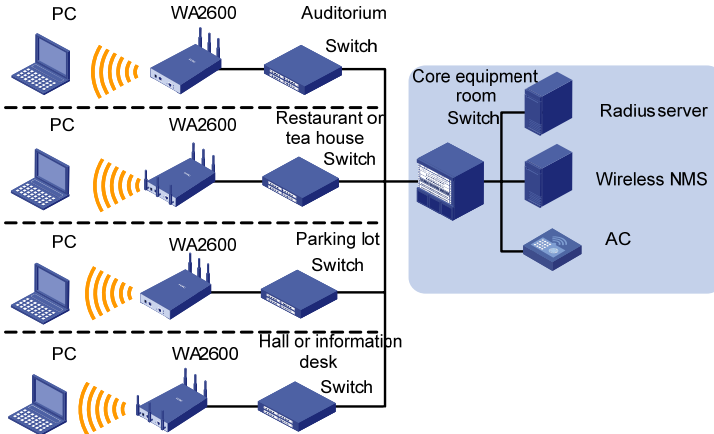

Figure 1-2 shows the appearance of the WA2600 series.

Figure 1-2 Appearance of the WA2600 series

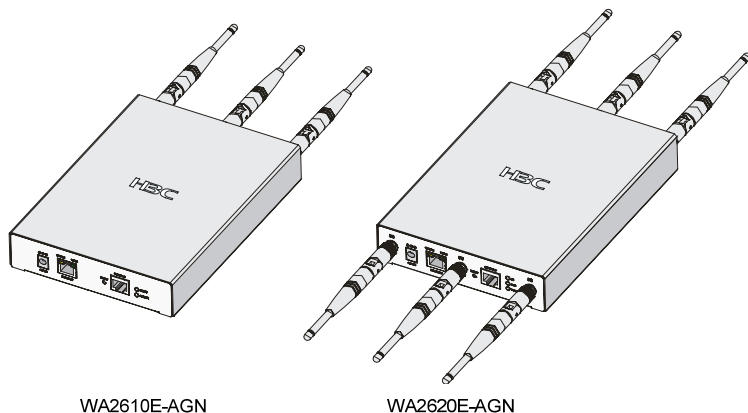

Table 1-1 Physical dimensions and weight of the WA2600 series

Model	Physical dimensions (H×W×D)	Weight
H3C WA2610E-AGN	35 × 210 × 150 mm (1.38 × 8.27 × 5.91 in.)	1.2 kg (2.65 lb.)
H3C WA2620E-AGN	35 × 210 × 150 mm (1.38 × 8.27 × 5.91 in.)	1.3 kg (2.87 lb.)

Hardware Configuration

The two models of the WA2600 series have different radio frequencies (RFs) and structures. Table 1-2 lists the supported protocols and the chassis material.

Table 1-2 Supported protocols and chassis material

Model	Protocols and chassis material
H3C WA2610E-AGN	IEEE 802.11a/b/g/n, single-RF, sheet metal

Model	Protocols and chassis material
H3C WA2620E-AGN	IEEE 802.11a/b/g/n, dual-RF, sheet metal

The following describes the hardware configurations and functions of the WA2600 series in detail.

LEDs

The positions and identifications of LEDs on the panel vary with the models. For details about these LEDs, see Table 1-3.

H3C WA2610E-AGN

Figure 1-3 LEDs on the H3C WA2610E-AGN

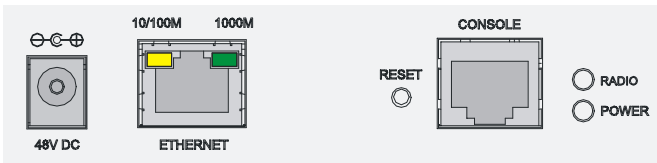

H3C WA2620E-AGN

Figure 1-4 LEDs on the H3C WA2620E-AGN

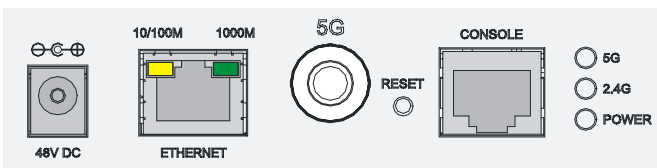

Table 1-3 Description of the LEDs on the WA2610E-AGN and WA2620E-AGN

LED	Color	QTY	Meaning
POWER	Green	1	Displays the power supply status: <ul style="list-style-type: none"> • On: The power supply is normal. • Off/blinking: The power supply is not well connected or works abnormally.
RADIO	Green	1	Displays the wireless link status: <ul style="list-style-type: none"> • On: The wireless link is normal. • Off: The wireless link is not initialized or the link is faulty. • Blinking slowly: The wireless link works normally. • Blinking rapidly: Data is being transmitted or received.
2.4GHz (Wireless link LED)	Green	1	Displays the 2.4 GHz wireless link status: <ul style="list-style-type: none"> • On: The wireless link is normal. • Off: The wireless link is not initialized or the link is faulty. • Blinking slowly: The wireless link works normally. • Blinking rapidly: Data is being transmitted or received.
5GHz (Wireless link LED)	Green	1	Displays the 5 GHz wireless link status: <ul style="list-style-type: none"> • On: The wireless link is normal. • Off: The wireless link is not initialized or the link is faulty. • Blinking slowly: The wireless link works normally. • Blinking rapidly: Data is being transmitted or received.

LED	Color	QTY	Meaning
10/100M (Ethernet interface LED)	Yellow	1	<p>Displays the status of the Ethernet interface:</p> <ul style="list-style-type: none"> • On: The Ethernet interface is in the link-up state. • Off: The Ethernet interface is in the link-down state. • Blinking: Data is being transmitted or received at 10/100 Mbps.
1000M (Ethernet interface LED)	Green	1	<p>Displays the status of the 1000 M Ethernet interface:</p> <ul style="list-style-type: none"> • On: The Ethernet interface is in the link-up state. • Off: The Ethernet interface is in the link-down state. • Blinking: Data is being transmitted or received at 1000 Mbps.

Interfaces

The WA2600 series provide the following interfaces:

- 2.4 GHz or 5 GHz antenna interfaces
- A console interface
- An Ethernet copper interface
- A power supply interface



In addition, the WA2600 series have a reset button and a security slot.

Interfaces provided by the H3C WA2610E-AGN

Figure 1-5 Interfaces on the H3C WA2610E-AGN

Top view

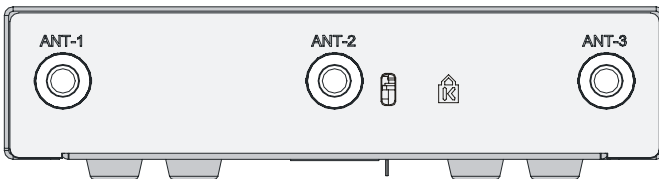

Bottom view

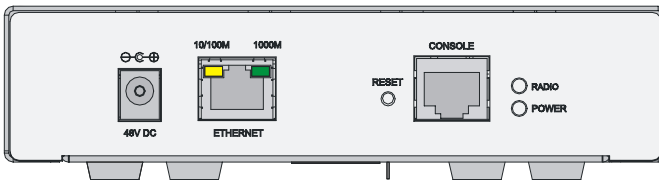

Interfaces provided by the H3C WA2620E-AGN

Figure 1-6 Interfaces on the H3C WA2620E-AGN

Top view

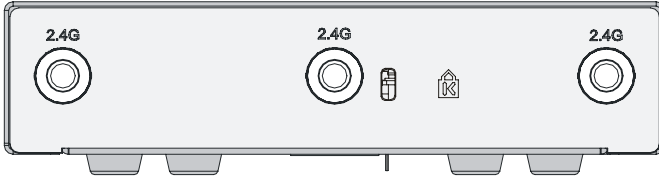

Bottom view

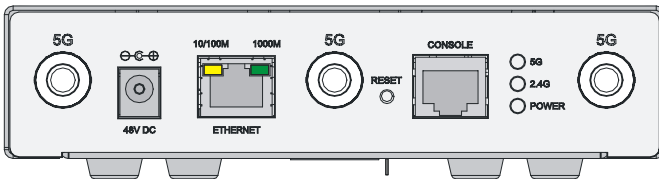

Table 1-4 describes the interfaces provided by each model.

Table 1-4 Descriptions of interfaces on the WA2600 series WLAN access points

Model	Interface	Standards and protocols	Description
WA2610 E-AGN	ANT-1 ANT-2 ANT-3	IEEE802.11 a IEEE802.11 b IEEE802.11 g IEEE802.11 n	The antenna interfaces are provided for 2.4 GHz/5 GHz dual-RF antennas for MIMO transmission.
	Console	RS/EIA-232	The console interface is used for device configuration and management.
	Ethernet	IEEE802.3 IEEE802.3u IEEE802.3af	The Ethernet interface can serve as an uplink interface to access the Internet or MAN, and as a PoE interface at the same time.
	Power supply	—	The power supply interface is used for +48 VDC power supply to the device.

Model	Interface	Standards and protocols	Description
WA2620 E-AGN	Antenna interface (2.4 G)	IEEE802.11 b IEEE802.11 g IEEE802.11 n	This antenna interface is used to connect a 2.4 GHz antenna or a feeder.
	Antenna interface (5 G)	IEEE802.11 a IEEE802.11 n	This antenna interface is used to connect a 5 GHz antenna or a feeder.
	Console	RS/EIA-232	The console interface is used for device configuration and management.
	Ethernet	IEEE802.3 IEEE802.3u IEEE802.3af	The Ethernet interface can serve as an uplink interface to access the Internet or MAN, and a PoE interface at the same time, supporting non-standard PoE power supply.
	Power supply	—	The power supply interface is used for +48 VDC power supply to the device.

2 Preparing for Installation

This chapter describes the preparations for WA2600 installation, including the preparation of installation tools, environment examination, unpacking and inspection.

Unpacking and Inspection

Before unpacking the package, make sure that the package is intact, without any serious damage or signs of water soaking. When unpacking the package, avoid excessive force or collision. Otherwise, the articles inside the package may get damaged.

After unpacking the package, make sure that the following articles are available in the package:

Table 2-1 List of articles in the package

Description	QTY
WA2600 WLAN AP	1 PCS
Power adapter	1 PCS
220 VAC power cord	1 PCS
Console cable	1 PCS
Installation kit	1 set
Omni antennas	3/6 PCS
H3C WA2600 Series WLAN Access Points Installation Manual	1 PCS
Packing list	1 PCS



Note

- The accessories may vary with the models. For the exact contents of the package, refer to the packing list.
 - If the contents do not check with the packing list, timely contact your local dealer.
 - If the package is found to be rusted or water soaked, stop unpacking and contact your local dealer immediately.
 - Three omni antennas are shipped with the WA2610E-AGN, while six omni antennas are shipped with the WA2620E-AGN.
-

Preparing Installation Tools

When installing the AP, you may need the tools listed in Table 2-2. Choose the appropriate tools according to the installation environment.

Table 2-2 List of installation tools

Type of tool	Indoor installation
General tools	1-meter-long rulers, marking pens, knives, and a percussion drill with appropriate bits
Special tools	Cable strippers, crimping pliers, and RJ-45 crimping pliers
Auxiliary tools	Ladders and rubber hammers



Note

Table 2-2 is for reference only. If you install the AP on a tabletop, none of the above tools is required.

Examining the Installation Site

Before installation, examine the installation site to make sure that the AP will work in a good environment. You can examine the installation site from the following two aspects.

Installation Site Selection

Keep the AP away from high temperature, dust, harmful gases, inflammables, explosive substances, electromagnetic interference sources (heavy-duty radars, radio stations, or electrical substations), unstable voltage, heavy vibration, or loud noise. The installation site should be dry, without any leakage, dripping or dew. The AP should be at least 500 m (0.31 miles) away from the seaside and should not face the direction of sea wind.

In engineering design, the site should be selected according to the network planning and technical requirements of the communications equipment, and the considerations such as climate, hydrology, geology, earthquake, electric power, and transportation.

Temperature and Humidity Requirements

Table 2-3 lists the operating temperature and humidity requirements.

Table 2-3 Environment specifications

Specification	Range
Operating temperature (indoor)	0°C to 45°C (32°F to 113°F)

Specification	Range
Storage temperature	-40°C to +70°C (-40°F to +158°F)
Relative humidity (noncondensing)	10% to 95%

Power Supply

Check that the power supply of the installation site is stable. The centralized AC power system consisting of the AC mains, UPS, and user-supplied diesel generator should be:

- Easy to connect
- Safe to operate
- Flexible to dispatch
- Convenient to maintain

The low-voltage power supply should adopt the single-phase three-wire system. Table 2-4 lists the nominal voltage and frequency of the low-voltage AC power supply.

Table 2-4 Nominal voltage and frequency of the low-voltage AC power supply

Power supply	Nominal voltage	Stable frequency
Single-phase three-wire (V)	100 VAC to 240 VAC	50/60 Hz



Caution

- If the voltage is unstable, a voltage regulator or stabilizer is required.
 - An uninterrupted power supply (UPS) is required for uninterrupted communication.
-

Grounding and Lightning Protection

Table 2-5 Grounding and lightning protection requirements

Item	Requirements
Grounding resistance	<ul style="list-style-type: none">• The grounding resistance is typically required to be less than 5 ohms, and less than 10 ohms in an area that has less than 20 thunderstorm days a year. If an angle iron is to be buried into the earth as the earthing conductor, the grounding resistance is required to be less than 10 ohms. If the installation site has a high earth resistance rate, it is recommended to spray some salt water or resistance-reducing agent on the earth around the buried earthing conductor to reduce the resistance rate of the earth.• The top of the earthing conductor should be at least 0.7 m (2.30 ft) away from the ground surface. In cold areas, the earthing conductor should be buried below the frozen soil layer.

Item	Requirements
Protection grounding	<ul style="list-style-type: none"> ● If a grounding strip is available at the site, attach the yellow-green PGND cable of the AP to the grounding strip. The PGND cable must have a cross-section area of at least 6 mm² (0.01 in²) and a length not longer than 3 m (9.84 ft). ● If no grounding strip is available at the site, hammer a 0.5 m (1.64 ft) or longer angle iron or steel tube into the earth. The angle iron should be sized at least 50 × 50 × 5 mm (1.97 × 1.97 × 0.20 in.); the steel tube should have a wall thickness of at least 3.5 mm (0.18 in.) and be zinc-plated. Weld the yellow-green grounding cable to the angle iron or steel tube and treat the joint for corrosion protection. With a cross-section area of at least 6 mm² (0.01 in²), the grounding cable should be as short as possible. Do not coil the cable. ● Make sure the lightning arresters of all devices and the peering devices connected to these devices are well grounded.
Grounding lead	<p>The grounding lead is a metal conductor connecting the grounding strip to the grounding grid. The PGND cable of the device should be attached to the grounding strip. The grounding lead should not be longer than 30 m (98.43 ft). A zinc-plated flat steel with a cross-section area of 40 × 4 mm (1.57 × 0.16 in) or 50 × 5 mm (1.97 × 0.20 in) is recommended. The grounding strip and the grounding lead should be jointed using a 35 mm² yellow-green PGND cable or directly welded together with the joint treated for corrosion protection.</p>
AC power grounding	<ul style="list-style-type: none"> ● Make sure you use the power cable with a PE terminal but not the cables with only L and N wires. ● It is strictly prohibited to connect the N wire of the power cable to the protection ground of any other communications device, and the L and N wires must be connected correctly.

Item	Requirements
Lightning rod	In a plain area, the protection angel of the lightning rod should be less than 45 degrees. In a mountainous area or lightning intensified area, the protection angle should be less than 30 degrees. The lightning protection ground (for example, the ground of the lightning rod) and the protection ground of the equipment room should be connected to the same earthing conductor.
Feeder	<ul style="list-style-type: none"> • The antenna support is ready and in accordance with the design requirement. • A feeder lightning rod is already installed and grounded according to the design requirement.
Outdoor lightning arresters	In case of outdoor installation, a power supply lightning arrester, a feeder lightning arrester and a network port lightning arrester are required. The power supply lightning arrester and feeder lightning arrester are located close to the AP while the network port lightning arrester is installed close to the peer device where the network cable goes out of the room.
Network cable	In case of outdoor installation, make sure to use a shielded network cable and the interconnected devices are well grounded.

After you have completed the preparations, you can start installing the AP. For details, refer to 3 "Installing the AP" on page 3-1.

3 Installing the AP

The WA2600 series WLAN APs can be directly fixed onto a wall by using the wall-mounting brackets. The following introduces the wall-mounting procedure of the WA2600 series in detail.

Installation Flowchart

Figure 3-1 shows the installation flowchart of the WA2600 series.

Figure 3-1 Installation flowchart

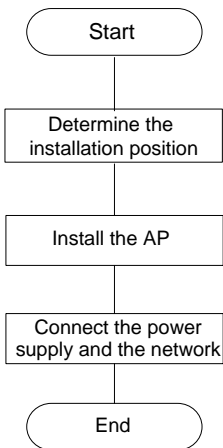

Determining the Installation Position

Determine the installation position by observing the following principles:

- Leave as few obstacles (such as wall and ceiling) as possible between the AP and the wireless stations.

- Keep the AP far away from electronic devices (such as microwave ovens) that may generate RF noise.
 - Install the AP in a place where it will not hinder people's daily work and life.
-



Make sure the ceiling is strong enough and the structure is suitable in case of ceiling mounting. Reinforce the ceiling if needed. A padlock is required for ceiling mounting to prevent any falloff in case of shocks. A Blossom 071 padlock or similar padlock is recommended.

Installing the AP on a Wall

The following describes how to install a WA2600 series AP on a wall:

- Installing the Wall-Mounting Bracket on the Wall
- Installing the AP on the Wall-Mounting Bracket
- Locking the AP onto the Wall-Mounting Bracket (Optional)

Installing the Wall-Mounting Bracket on the Wall

- 1) Drill holes 6 mm (0.24 in) in diameter on the wall where the AP is to be mounted. The drilled holes must correspond to those in the wall-mounting bracket. There are eight installation holes in total in the wall-mounting bracket. Select at least four of them for the installation.

Figure 3-2 Screw hole locations and screw hole size

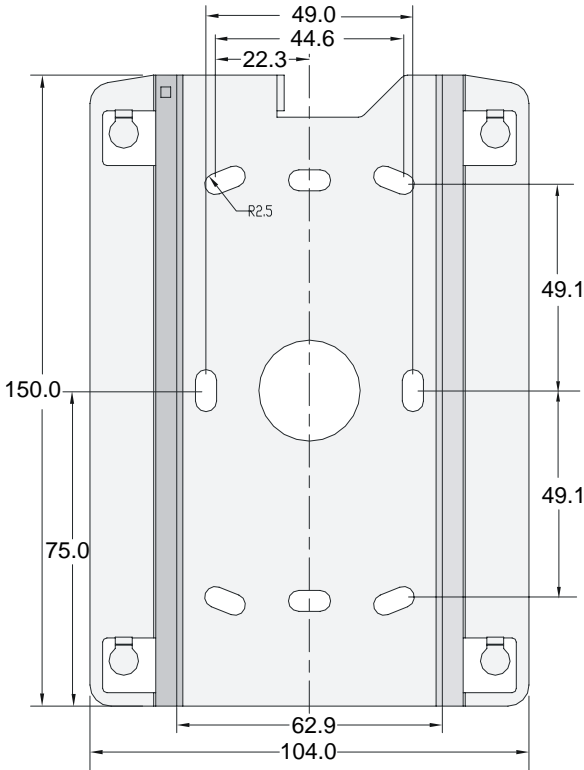

- 2) Insert the pointed end of anchors into the drilled holes and tap the flat end of anchors with a rubber hammer until they are all flush with the wall surface.
- 3) Align the holes in the wall-mounting bracket with the anchors and insert screws through the installation holes into the anchors, as shown in Figure 3-3.
- 4) Adjust the position of the wall-mounting bracket and tighten the screws.

Figure 3-3 Install the wall-mounting bracket

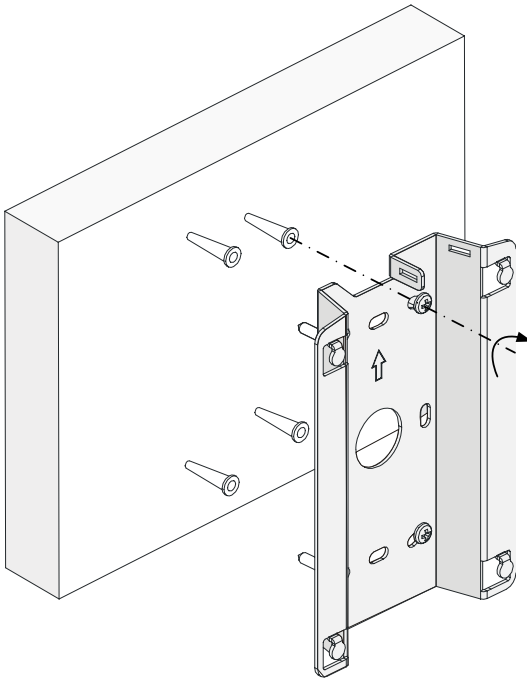

 **Note**

Install the wall-mounting bracket with the arrow on the bracket pointing upwards.

Installing the AP on the Wall-Mounting Bracket



Note

The installation procedure is the same for both the WA2610E-AGN and WA2620E-AGN. The WA2610E-AGN is taken as an example in this manual.

- 1) Align the AP with the hooks on the wall-mounting bracket and hang the AP on the bracket. See (1) in Figure 3-4.
- 2) Press the AP downward to fix it. See (2) in Figure 3-4.

Figure 3-4 Fix the AP onto the wall-mounting bracket

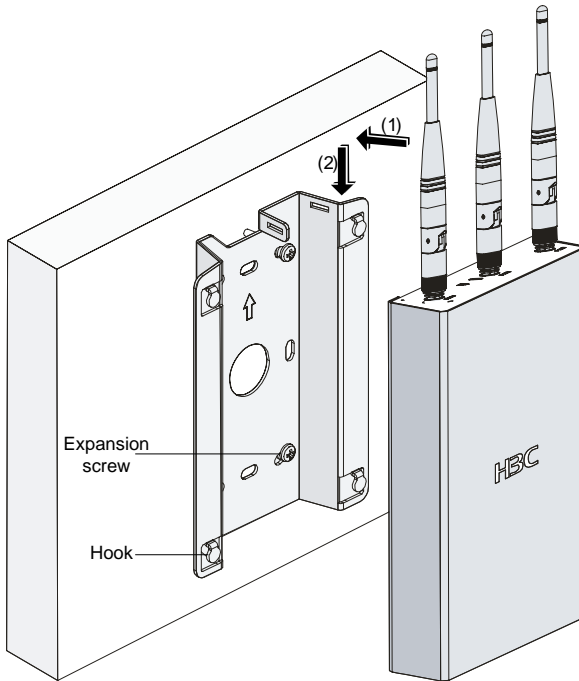

Locking the AP onto the Wall-Mounting Bracket (Optional)

The WA2600 series APs have a security slot on the top, which can be used to lock the AP onto the wall-mounting bracket to prevent theft. Follow these steps to lock the AP onto the wall-mounting bracket:

- 1) Insert the locking plate into the security slot on the top of the AP. See (1) in Figure 3-5.
- 2) Turn the locking plate counterclockwise until the hole on the locking plate is aligned with the hole in the wall-mounting bracket. See (2) in Figure 3-5.
- 3) Put the latch through the two holes that are aligned in step 2. See (3) in Figure 3-5.
- 4) Lock the latch with a lock.

Figure 3-5 Lock the AP onto the wall-mounting bracket

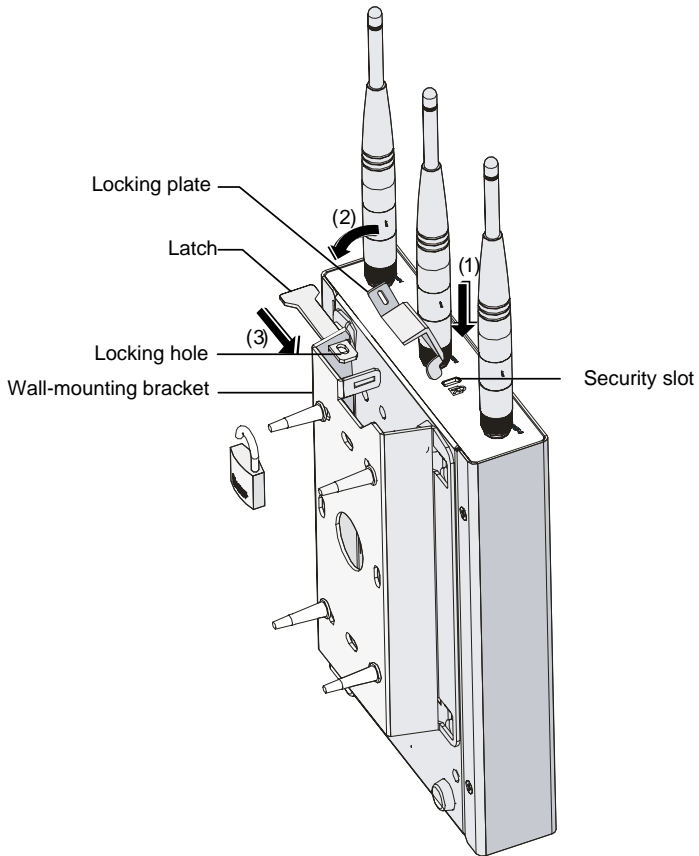

 **Note**

The lock is user supplied.

Connecting the Power Supply

Local Power Supply

Connect the AP to the power source through the power adapter, as shown in Figure 3-6.

Figure 3-6 Local power supply connection

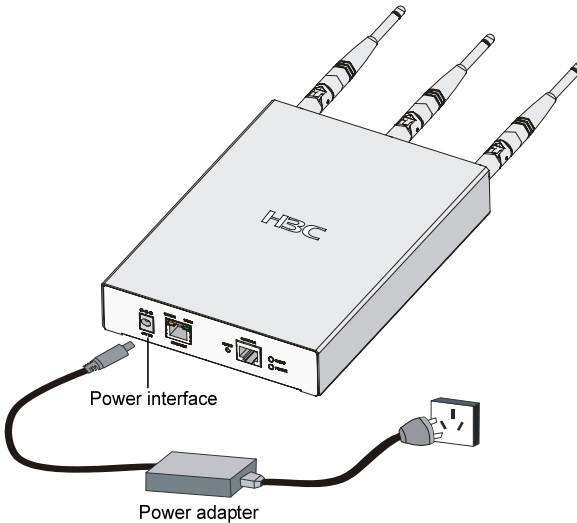

Power over Ethernet

If the uplink device of the AP is a PoE-capable switch or the like, use an Ethernet cable to connect the Ethernet interface of the AP to the PoE-capable device.

Figure 3-7 PoE connection

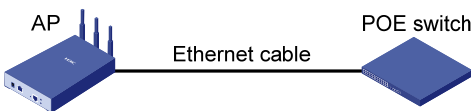



Caution

- In the PoE mode, you do not need to connect the power interface to a power source. You only need to connect one end of an Ethernet cable to the Ethernet interface of the AP and the other end to an Ethernet interface of the PoE-capable device (for example, an Ethernet switch).
 - Identify the silkscreen on the device to avoid taking the console interface for the Ethernet interface, or vice versa.
 - The WA2620E-AGN supports only non-standard PoE power supply.
-

Connecting the AP to the Network

The WA2600 series can access the Internet or MAN through the Ethernet uplink interface. Connect the Ethernet interface of the AP to an Ethernet interface of an Ethernet switch to implement Internet or MAN access, as shown in Figure 3-8.

Figure 3-8 Connect the AP to the network

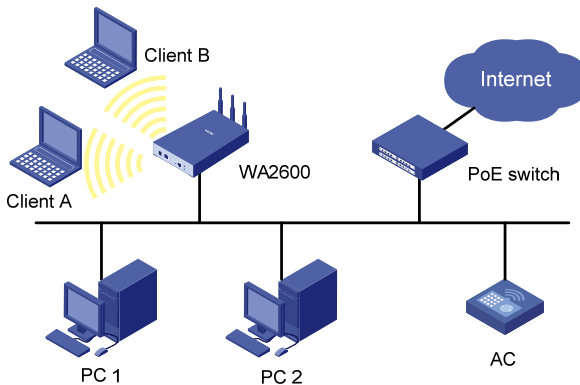

Table of Contents

1 Regulatory Compliance Information.....	1-1
Regulatory compliance standards.....	1-1
Support Antennas & Accessories information.....	1-1
EU Compliance information	1-3
CE Marking	1-3
EU Country Restriction in 2.4GHz band	1-6
EU Country Restriction in 5GHz band	1-6
WEEE Directive–2002/96/EC	1-7
USA Compliance information	1-8
US Federal Communications Commission statement.....	1-8
RF Requirements.....	1-8
Antennas.....	1-9
WLAN Module.....	1-9
Industry Canada	1-9
RF Compliance	1-9
Brazil RF Compliance	1-10
Korea RF Compliance.....	1-11
Taiwan regulatory statement.....	1-12
2 Safety Information Sicherheitsinformationen.....	2-1
General Requirements Allgemeine Anforderungen	2-1
Electricity Safety Elektrische Sicherheit.....	2-2

1 Regulatory Compliance Information

Regulatory compliance standards

Table 1-1 Regulatory compliance standards

Discipline	Standards
EMC & RF	FCC Part 15.207 & 15.209 & 15.247& 15.205 & 15.407 FCC Bulletin OET-65C IC RSS 210 ETSI EN 300 328 ETSI EN 301 893 EN 60601-1-2 EN 61000-3-2 EN 61000-3-3 ETSI EN 301 489-1 ETSI EN 301 489-17
Safety	UL 60950-1 CAN/CSA C22.2 No 60950-1 IEC 60950-1 EN 60950-1

Support Antennas & Accessories information

This product can be used with the following antennas and accessories:

Table 1-2 Authorized Antennas & Accessories

Item	Description	Exclusions
	Supplied Antenna	None
C5060-510002-A	3Com 2/8dBi Dual-Band Omni Antenna	None

Item	Description	Exclusions
3CWE591	3Com 6/8dBi Dual-Band Omni Antenna	Must be used with 3CWE586 and one of the following: 3CWE580, 3CWE581 or 3CWE582.
3CWE596	3Com 18/20dBi Dual-Band Panel Antenna	Must be used with 3CWE586 and one of the following: 3CWE580, 3CWE581 or 3CWE582.
3CWE598	3Com 8/10dBi Dual-Band Panel Antenna Product	Must be used with 3CWE586 and one of the following: 3CWE580, 3CWE581 or 3CWE582.
TQJ-24/58MICX6	2.5dBi/4.5dBi Dual-Band MIMO Antenna	Depend on availability.
TQJ-2458MIKX3	2.5dBi/4dBi Dual-Band MIMO Antenna	Depend on availability.
MCM2458PTRPS M	3dBi/4dBi Dual-Band MIMO Antenna	Depend on availability.
3CWE580	3Com Ultra Low Loss 6-Foot Antenna Cable	Must also use 3CWE586.
3CWE581	3Com Ultra Low Loss 20-Foot Antenna Cable	Must also use 3CWE586.
3CWE582	3Com Ultra Low Loss 50-Foot Antenna Cable	Must also use 3CWE586.
3CWE586	3Com RSMA to SMA 6-inch Antenna Cable	Required for all external antennas (not required for 3CWE590 Antenna).

- This product does not contain any user serviceable components. Any unauthorized product changes or modifications will invalidate the warranty and all applicable regulatory certifications and approvals.
- This product must be installed by a professional technician/installer.

EU Compliance information

CE Marking



Equipment may be operated in the following country:

AT	BE	CY	CZ	DK	EE	FI	FR
DE	GR	HU	IE	IT	LV	LT	LU
MT	NL	PL	PT	SK	SI	ES	SE
GB	IS	LI	NO	CH	BG	RO	TR

- 1) Select the country in which the product is installed to ensure product operation is in compliance with local regulations. For information on how to select the country, refer to the “Wireless Configuration Command” module in H3C Wireless Control Manager Command Manual.
- 2) Intended use: IEEE 802.11a/b/g and 802.11n Draft 2.0.
- 3) This product must maintain a minimum body to antenna distance of 20cm. Under these conditions this product will meet the Basic Restriction limits of 1999/519/EC (Council Recommendation of 12 July 1999 on the limitation of exposure of the general public to electromagnetic fields (0Hz-300GHz)).

R&TTE declaration statements:

Česky [Czech]	H3C Coporation tímto prohlašuje, že tento <i>RLAN device</i> je ve shodě se základními požadavky a dalšími příslušnými ustanoveními směrnice 1999/5/ES.
Dansk [Danish]	Undertegnede H3C Corporation erklærer herved, at følgende udstyr <i>RLAN device</i> overholder de væsentlige krav og øvrige relevante krav i direktiv 1999/5/EF.

Deutsch [German]	Hiermit erklärt H3C Corporation, dass sich das Gerät <i>RLAN device</i> in Übereinstimmung mit den grundlegenden Anforderungen und den übrigen einschlägigen Bestimmungen der Richtlinie 1999/5/EG befindet.
Eesti [Estonian]	Käesolevaga kinnitab H3C Corporation seadme <i>RLAN device</i> vastavust direktiivi 1999/5/EÜ põhinõuetele ja nimetatud direktiivist tulenevatele teistele asjakohastele sätetele.
English	Hereby, H3C Corporation, declares that this <i>RLAN device</i> is in compliance with the essential requirements and other relevant provisions of Directive 1999/5/EC.
Español [Spanish]	Por medio de la presente H3C Corporation declara que el <i>RLAN device</i> cumple con los requisitos esenciales y cualesquiera otras disposiciones aplicables o exigibles de la Directiva 1999/5/CE.
Ελληνική [Greek]	ΜΕ ΤΗΝ ΠΑΡΟΥΣΑ Η3C Corporation ΔΗΛΩΝΕΙ ΟΤΙ <i>RLAN device</i> ΣΥΜΜΟΡΦΩΝΕΤΑΙ ΠΡΟΣ ΤΙΣ ΟΥΣΙΩΔΕΙΣ ΑΠΑΙΤΗΣΕΙΣ ΚΑΙ ΤΙΣ ΛΟΙΠΕΣ ΣΧΕΤΙΚΕΣ ΔΙΑΤΑΞΕΙΣ ΤΗΣ ΟΔΗΓΙΑΣ 1999/5/EK.
Français [French]	Par la présente H3C Corporation déclare que l'appareil <i>RLAN device</i> est conforme aux exigences essentielles et aux autres dispositions pertinentes de la directive 1999/5/CE.
Italiano [Italian]	Con la presente H3C Corporation dichiara che questo <i>RLAN device</i> è conforme ai requisiti essenziali ed alle altre disposizioni pertinenti stabilite dalla direttiva 1999/5/CE.
Latviski [Latvian]	Ar šo H3C Corporation deklarē, ka <i>RLAN device</i> atbilst Direktīvas 1999/5/EK būtiskajām prasībām un citiem ar to saistītajiem noteikumiem.
Lietuvių [Lithuanian]	Šiuo H3C Corporation deklaruoja, kad šis <i>RLAN device</i> atitinka esminius reikalavimus ir kitas 1999/5/EB Direktyvos nuostatas.
Nederlands [Dutch]	Hierbij verklaart H3C Corporation dat het toestel <i>RLAN device</i> in overeenstemming is met de essentiële eisen en de andere relevante bepalingen van richtlijn 1999/5/EG.
Malti [Maltese]	Hawnhekk, H3C Corporation, jiddikjara li dan <i>RLAN device</i> jikkonforma mal-ħtiġijiet essenzjali u ma provvedimenti oħrajn rilevanti li hemm fid-Dirrettiva 1999/5/EC.

Magyar [Hungarian]	Alulírott, H3C Corporation nyilatkozom, hogy a <i>RLAN device</i> megfelel a vonatkozó alapvető követelményeknek és az 1999/5/EC irányelv egyéb előírásainak.
Polski [Polish]	Niniejszym H3C Corporation oświadcza, że <i>RLAN device</i> jest zgodny z zasadniczymi wymogami oraz pozostałymi stosownymi postanowieniami Dyrektywy 1999/5/EC.
Português [Portuguese]	H3C Corporation declara que este <i>RLAN device</i> está conforme com os requisitos essenciais e outras disposições da Directiva 1999/5/CE.
Slovensko [Slovenian]	H3C Corporation izjavlja, da je ta <i>RLAN device</i> v skladu z bistvenimi zahtevami in ostalimi relevantnimi določili direktive 1999/5/ES.
Slovensky [Slovak]	H3C Corporation týmto vyhlasuje, že <i>RLAN device</i> spĺňa základné požiadavky a všetky príslušné ustanovenia Smernice 1999/5/ES.
Suomi [Finnish]	H3C Corporation vakuuttaa täten että <i>RLAN device</i> tyyppinen laite on direktiivin 1999/5/EY oleellisten vaatimusten ja sitä koskevien direktiivin muiden ehtojen mukainen.
Svenska [Swedish]	Härmed intygar H3C Corporation att denna <i>RLAN device</i> står i överensstämmelse med de väsentliga egenskapskrav och övriga relevanta bestämmelser som framgår av direktiv 1999/5/EG.
Íslenska [Icelandic]	Hér með lýsir H3C Corporation yfir því að <i>RLAN device</i> er í samræmi við grunnkröfur og aðrar kröfur, sem gerðar eru í tilskipun 1999/5/EC.
Norsk [Norwegian]	H3C Corporation erklærer herved at utstyret <i>RLAN device</i> er i samsvar med de grunnleggende krav og øvrige relevante krav i direktiv 1999/5/EF.

A copy of the signed Declaration of Conformity can be downloaded from:

http://www.h3c.com/portal/Technical_Documents

http://support.3com.com/doc/H3C_WA26XXE-AGN_EU_DOC.pdf

Table 1-3 Overview of Regulatory Requirements for Wireless LANs

Frequency Band (MHz)	Max Power Level	(EIRP) (mW) Indoor ONLY	Indoor and Outdoor
2400 – 2483.5	100 mW		X
5150 – 5250	50 mW	X	
5250 – 5350	200 mW	X	
5470 – 5725	1000 mW		X



Note

Dynamic Frequency Selection and Transmit Power Control is required in the 5250- to 5350-MHz and 5470- to 5725-MHz frequency range.

EU Country Restriction in 2.4GHz band

This device may be used indoors or outdoors in all countries of the European Community using the 2.4GHz band: Channel 1-13, except where noted below.

- 1) In France, the output power is restricted to 10 mW EIRP when the product is used outdoors in the band 2454 - 2483.5 MHz. There are no restrictions when used in other parts of the 2.4 GHz band.

EU Country Restriction in 5GHz band

- 1) In Italy the end-user must apply for a license from the national spectrum authority to operate this device outdoors.
- 2) To remain in conformance with European spectrum usage laws for Wireless LAN operation, the above 2.4GHz and 5GHz channel limitations apply. The user should check the current channel of operation. If operation is occurring outside of the allowable frequencies as listed above, the user must cease operating the

WA2600 series at that location and consult the local technical support staff responsible for the wireless network.

- 3) This device must be used with the radar detection feature required for European Community operation in the 5GHz bands. This device will avoid operating on a channel occupied by any radar system in the area. The presence of nearby radar operation may result in temporary interruption in communications of this device. The Access Point's radar detection feature will automatically restart operation on a channel free of radar. You may consult with the local technical support staff responsible for the wireless network to ensure the Access Point device(s) are properly configured for European Community operation.

Europe-Restrictions for Use of 5GHz Frequencies in European Community Countries

Allowed Frequency Bands	Allowed Channel Numbers	Countries
5.15-5.35& 5.470-5.725G Hz	36,38,40,44,46,48,52,54,56,60,62,64,100,102,104,108,110,112,116,118,120,124,126,128,132,134,136,140	Austria, Belgium, Bulgaria, Cyprus, Czech Republic, Denmark, Estonia, Finland, France, Germany, Greece, Hungary, Iceland, Ireland, Italy, Latvia, Liechtenstein, Lithuania, Luxembourg, Malta, Netherlands, Norway, Poland, Portugal, Slovakia, Slovenia, Spain, Sweden, Switzerland, U.K.

WEEE Directive–2002/96/EC



The products this manual refers to are covered by the Waste Electrical & Electronic Equipment (WEEE) Directive and must be disposed of in a responsible manner.

USA Compliance information

US Federal Communications Commission statement

This device complies with Part 15 of the FCC Rules. Operation is subject to the following two conditions:

- This device may not cause harmful interference.
- This device must accept any interference received, including interference that may cause undesired operation.

RF Requirements

RF exposure Hazard Warning

This device generates and radiates radio-frequency energy. In order to comply with FCC radio-frequency exposure guidelines for an uncontrolled environment, this equipment must be installed and operated while maintaining a minimum body to antenna distance of 20 cm (approximately 8 in.)

Note: Minimum distance 40cm is required when 3CWE596 antenna is used.

RF Frequency Requirements

This equipment complies with FCC RF radiation exposure limits set forth for an uncontrolled environment. This device and its antenna must not be co-located or operating in conjunction with any other unauthorized antenna or transmitter.

This device is for indoor use only when using all channels in the 5.15 to 5.25 GHz, 5.47 to 5.6GHz or 5.65 to 5.725GHz frequency range. High power radars are allocated as primary users of the 5.25 to 5.35 GHz and **-5.47 to 5.6 GHz and 5.65 to 5.725 GHz** bands.

These radar stations can cause interference with and/or damage this device.

This device will not operations on channels which overlap the 5600 - 5650 MHz band

USA Restriction in 2.4GHz band

This device may be used in USA using the 2.4GHz band: Channel 1-11.

Antennas

Only use the supplied antenna. Unauthorized antennas, modifications or change to the antennas could violate FCC regulations and void the user's authority to operate the equipment.

Industry Canada

RF Compliance

This Class B digital apparatus complies with Canadian ICES-003.

Cet appareil numérique de la classe B est conform à la norme NMB-003 du Canada.

This device complies with RSS 210 of Industry Canada.

Operation is subject to the following two conditions: (1) this device may not cause interference, and (2) this device must accept any interference, including interference that may cause undesired operation of this device.

L ' utilisation de ce dispositif est autorisée seulement aux conditions suivantes: (1) il ne doit pas produire de brouillage et (2) l' utilisateur du dispositif doit être prêt à accepter tout brouillage radioélectrique reçu, même si ce brouillage est susceptible de compromettre le fonctionnement du dispositif.

The term "IC" before the equipment certification number only signifies that the Industry Canada technical specifications were met.

To reduce potential radio interference to other users, the antenna type and its gain should be so chosen that the equivalent isotropically radiated power (EIRP) is not more than that required for successful communication. To prevent radio interference to the licensed service, this device is intended to be operated indoors and away from windows to provide maximum shielding. Equipment (or its transmit antenna) that is installed outdoors is subject to licensing.

Pour empêcher que cet appareil cause du brouillage au service faisant l'objet d'une licence, il doit être utilisé à l'intérieur et devrait être placé loin des fenêtres afin de fournir un écran de blindage maximal. Si le matériel (ou son antenne d'émission) est installé à l'extérieur, il doit faire l'objet d'une licence.

This device is for indoor use only when using channels 36, 38, 40, 42, 44, 46 or 48 in the 5.15 to 5.25 GHz frequency range.

High power radars are allocated as primary users of the 5.25 to 5.35 GHz and **-5.47 to 5.6 GHz and 5.65 to 5.725GHz** bands. These radar stations can cause interference with and/or damage this device.

This device will not operate on channels which overlap the 5600 - 5650 MHz band

This device must not be co-located or operated in conjunction with any other unauthorized antenna or transmitter.

RF exposure Hazard Warning

Minimum distance 40cm is required when 3CWE596 antenna is used.

Brazil RF Compliance

Este produto está homologado pela ANATEL, de acordo com os procedimentos regulamentados pela Resolução 242/2000 e atende aos requisitos técnicos aplicados.

Este equipamento opera em caráter secundário, isto é, não tem direito a proteção contra interferência prejudicial, mesmo de estações do mesmo tipo, e não pode causar interferência a sistemas operando em caráter primário.

Para maiores informações, consulte o site da ANATEL – www.anatel.gov.br

Korea RF Compliance

This device may cause radio interference during its operation. Therefore service in relation to human life security is not available.

" 당해 무선설비는 전파혼신 가능성이 있으므로 인명안전과 관련된 서비스는 할 수 없음 "

Taiwan regulatory statement

- 1) 經審驗合格之射頻電信終端設備，非經許可，公司商號或使用者均不得擅自變更頻率，加大功率或功率或變更原設計之特性及功能。
- 2) 射頻電信終端設備之使用不得影響飛航安全及干擾合法通信；經發現有干擾現象時，應立即停用，並改善至無干擾時方得繼續使用。所謂合法通信，係指依電信法規定作業之無線電信。
- 3) 輸入、製造射頻電信終端設備之公司、商號或其使用者違反本辦法規定，擅自使用或變更無線電頻率、電功率者，除依電信法規定處罰外，電信總局並得撤銷其審驗合格證明。
- 4) 本機限在不干擾合法電台與不受被干擾保障條件下於室內使用。
- 5) 在 5.25-5.35 兆赫頻帶內操作之無線資訊傳輸設備，限於室內使用。
- 6) 無線資訊傳輸設備的製造廠商應確保頻率穩定性，如依製造廠商使用手冊上所述正常操作，發射的信號應維持於操作頻帶中。
- 7) 為減少電磁波干擾，請妥適使用。

2 Safety Information

Sicherheitsinformationen

General Requirements Allgemeine Anforderungen

In order to reduce the technically unavoidable residual risk to a minimum, it is imperative to follow the rules below:

Um das technisch bedingte Restrisiko auf ein Minimum zu begrenzen, ist es unbedingt erforderlich, die folgenden Regeln zu beachten:

- Read all the instructions before operation.
- Lesen Sie alle Anweisungen sorgfältig durch, bevor Sie mit dem Arbeiten beginnen.
- Do not block ventilation openings while the system is on, and keep at least 5 cm distance from ventilation openings and walls or other things which may block the openings.
- Sorgen Sie dafür, dass die Öffnungen der Ventilation zu keinem Zeitpunkt verschlossen, verstopft oder anderweitig blockiert sind. Zwischen den Ventilationsöffnungen und Wänden bzw. anderen Gegenständen muss stets ein Abstand von mindestens 5cm bestehen.
- For AC supplied model: To ensure the safety of the equipment and human body, please unplug the AC power connector and do not use the fixed terminal in the lightning weather. Furthermore, please do not touch the terminal or antenna connector in such weather.
- Mit Wechselstrom betriebenes Modell: Um die Sicherheit des Personals und der Ausrüstung zu gewährleisten, muss der Stecker aus der Steckdose gezogen werden, wenn die Gefahr eines Blitzeinschlages besteht. Verwenden Sie bei Blitzgefahr

keine festinstallierten Steckdosen. Berühren Sie bei Blitzgefahr nicht die Antenne.

- To ensure the equipment mounted on the wall firmly, please use nail at least 4.2mm diameter and the nail cap at least 8mm diameter.
- Um die Sicherheit der Ausrüstung auf der Wand, der Nagel in der Wand muss einen Durchmesser 4.2mm mindestens haben und der Durchmesser von der Nagelkappe muss grösser als 8mm sein.

Electricity Safety Elektrische Sicherheit

- Conducting articles, such as watch, hand chain, bracelet and ring are prohibited during the operation.
- Es ist nicht erlaubt während dieser Arbeiten leitende Gegenstände wie Uhren, Armbänder, Armreifen und Ringe am Körper zu tragen.
- When water is found in the rack, or the rack is damp, please immediately switch off the power supply.
- Sollte sich Wasser im Baugruppenträger befinden oder der Baugruppenträger feucht sein, ist die Energiezufuhr sofort zu unterbrechen und das System abzuschalten.
- When operation is performed in a damp environment, make sure that water is kept off the equipment.
- Muss in einem feuchten Umgebung gearbeitet werden, ist sicherzustellen, dass kein Wasser in die Ausrüstung dringen kann.